

115.00 mm

145.00 mm

ring

Video Doorbell 2



Home Security Begins at the Front Door

Your new Ring Video Doorbell is the start of a Ring of Security around your entire property.

Now, you'll always be connected to your home, so you can watch over your property and answer the door from anywhere.

See who's at your door, prevent crime and protect your home – all from your phone, tablet or PC.

Contents

1. Charging
2. In-app Setup
3. Physical Installation
4. Features
5. Troubleshooting

1. Charge the provided battery.

Charge the provided battery

First, fully charge the battery by plugging it into a power source using the provided orange cable.

The small light on top will glow green once fully charged.

 = Charging  = Charged

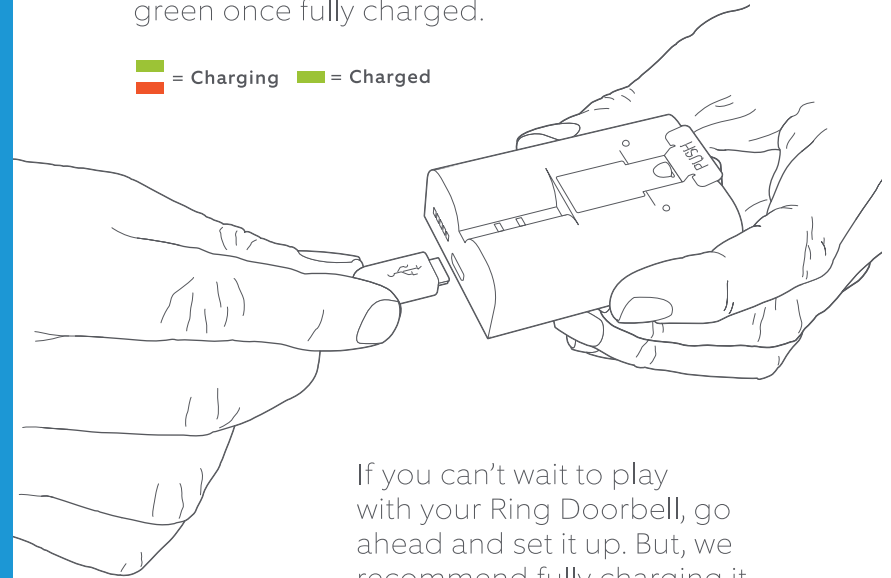

If you can't wait to play with your Ring Doorbell, go ahead and set it up. But, we recommend fully charging it before installation.

Insert the battery

After charging, insert the battery in the bottom of your Ring Doorbell until it clicks into place.

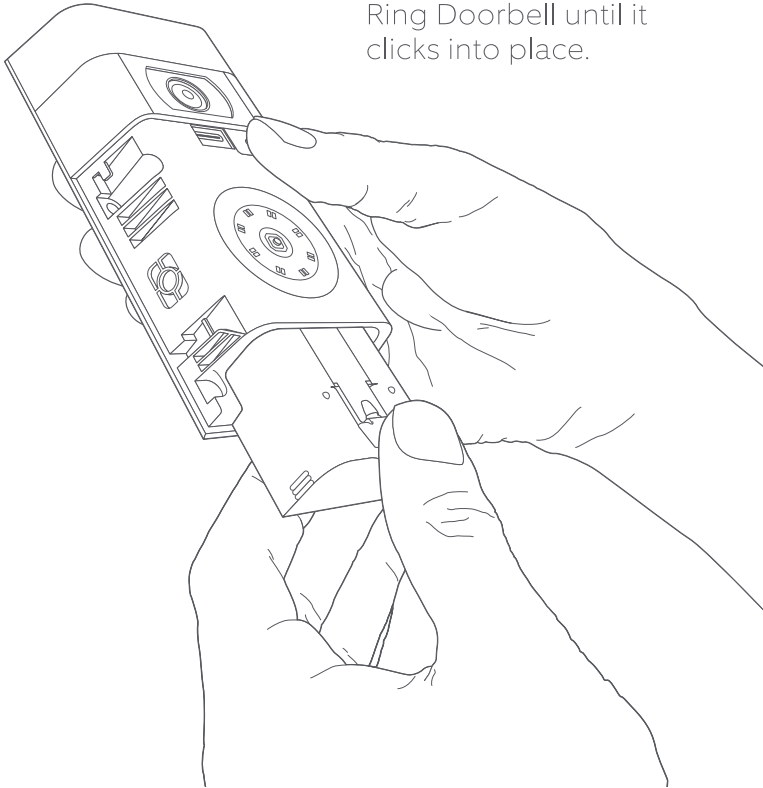

2. Set up your Ring Video Doorbell 2 in the Ring app.

Download the Ring app

The Ring app will walk you through setting up and managing your Ring Doorbell.

Search for “Ring” in one of the app stores below, or visit: ring.com/app.



Grab your Wi-Fi password

It's required for the in-app setup. Write it down below so it's handy when you need it:

Your Wi-Fi password 

Set up your Ring Video Doorbell near your router

In the Ring app, select **Set Up a Device**.

When prompted, select **Ring Video Doorbell 2** and follow the in-app instructions.

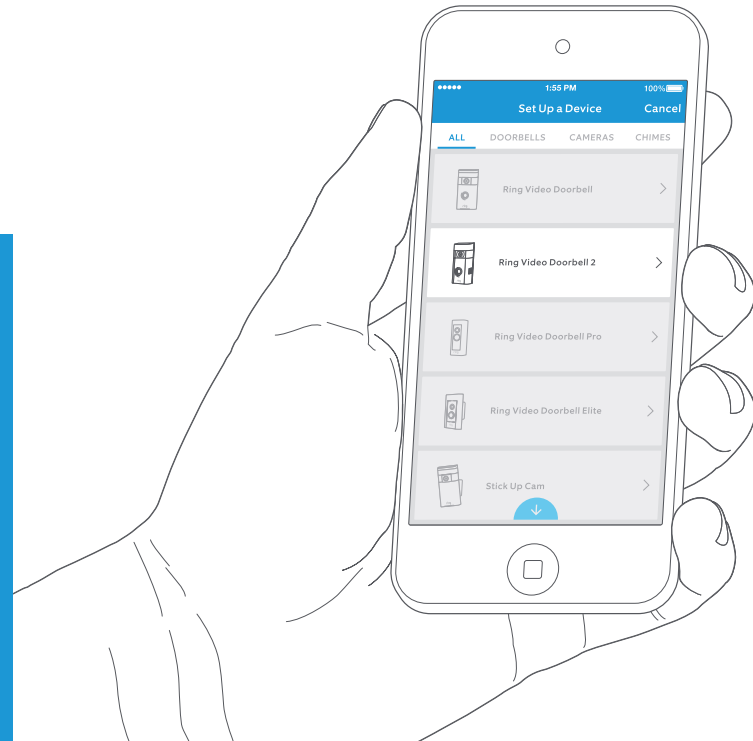

Try it out!

After setup, push the button on the front of your Ring Doorbell to see video from the camera in the Ring app.

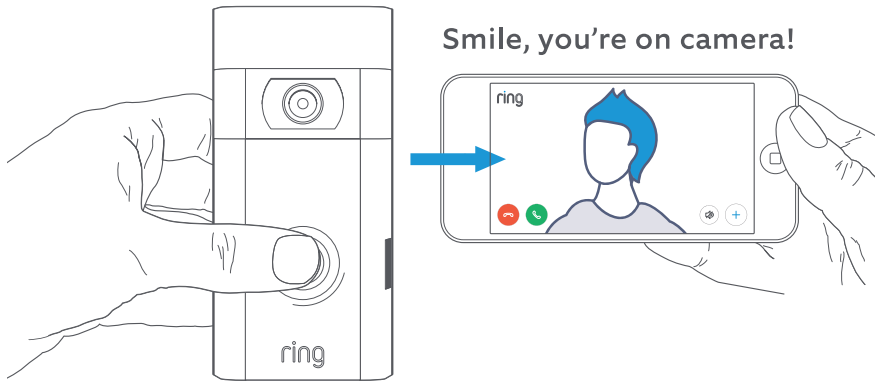

3. Install your Ring Video Doorbell 2 on the wall.

Next, test video quality where you will install your Ring Doorbell.

Everything look good? Continue to the next section.

Something not right? Jump ahead to the troubleshooting section.

Select an install height

Install your Ring Doorbell four feet off the ground for optimal performance.

If you're connecting to existing doorbell wiring that's higher than four feet, thus limiting where you can install Ring Doorbell, use the provided wedge mount to angle your Ring Doorbell down.

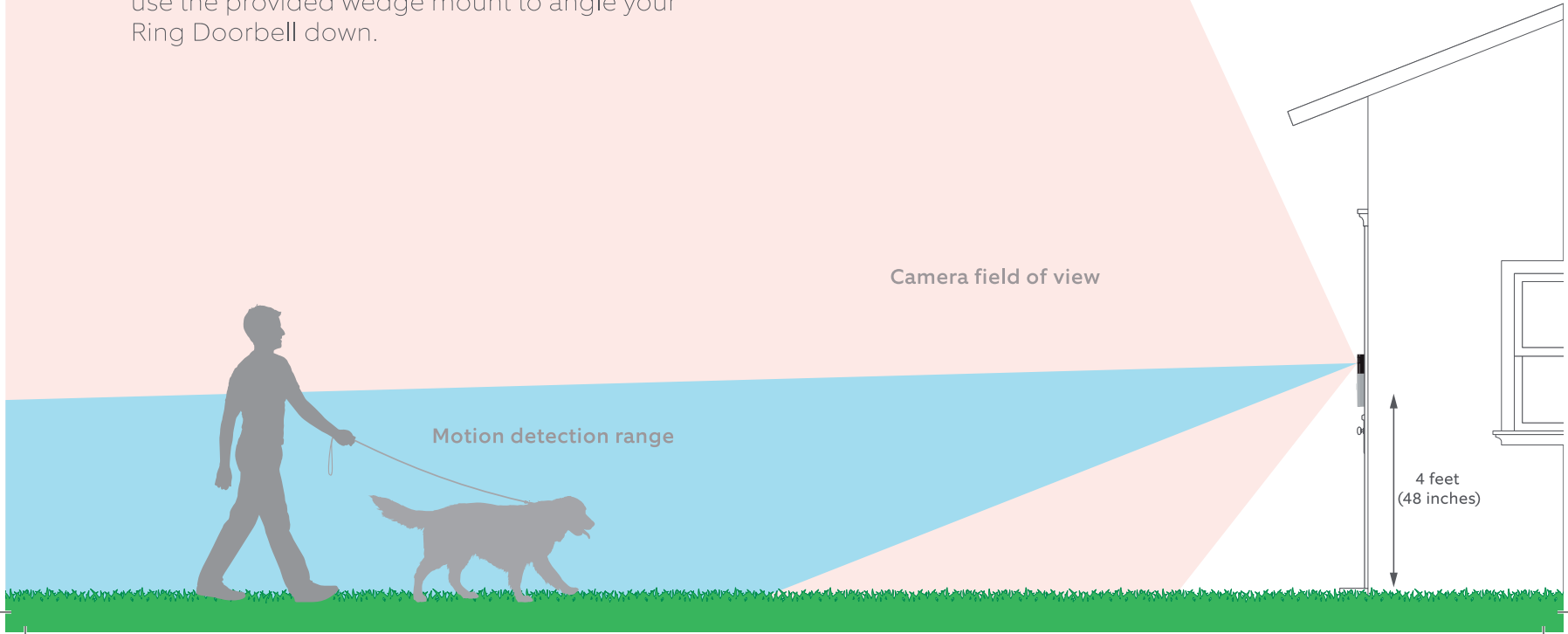

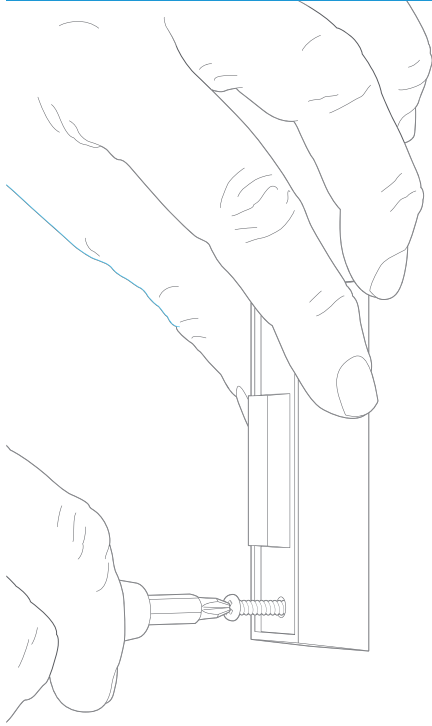

Remove your existing doorbell (optional)

If replacing an existing doorbell, shut off power at the breaker. Then remove it from the wall and disconnect the wires.

i If wiring your Ring Doorbell to an existing doorbell, a transformer with a voltage of 8–24VAC is required. If wiring directly to a transformer, a resistor must be used.

DC transformers and most intercoms are not supported.

Install the diode (optional)

If you're wiring your Ring Doorbell to a **digital doorbell** – you'll know it's digital if it plays a synthesized melody – then install the included diode.

If your existing doorbell is mechanical, **DO NOT** use the diode, as it can damage your existing doorbell.

Not sure? Visit ring.com/diode

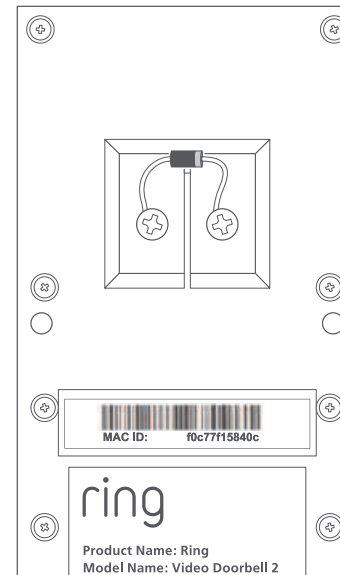

i The lighter band on your diode should be on the same side as the wire that runs to the "Front" terminal on your bell.

If you don't know which side this is, don't worry, since wiring the diode the wrong way can't do any harm.

If your bell doesn't ring when pushing the button on your Ring Doorbell, just reverse the wires on the back of your Ring Doorbell and try again.

Insert the mini-level

Insert the mini-level into your Ring Doorbell to make sure it's even when you install it.

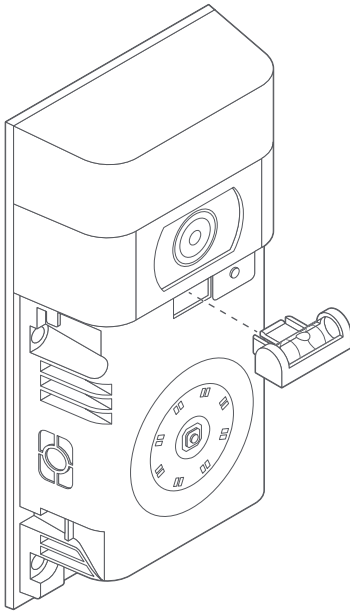

Install anchors (optional)

If installing on **stucco, brick, or concrete**, mark 4 drill holes. Use the provided bit to drill holes in your wall and insert the anchors.

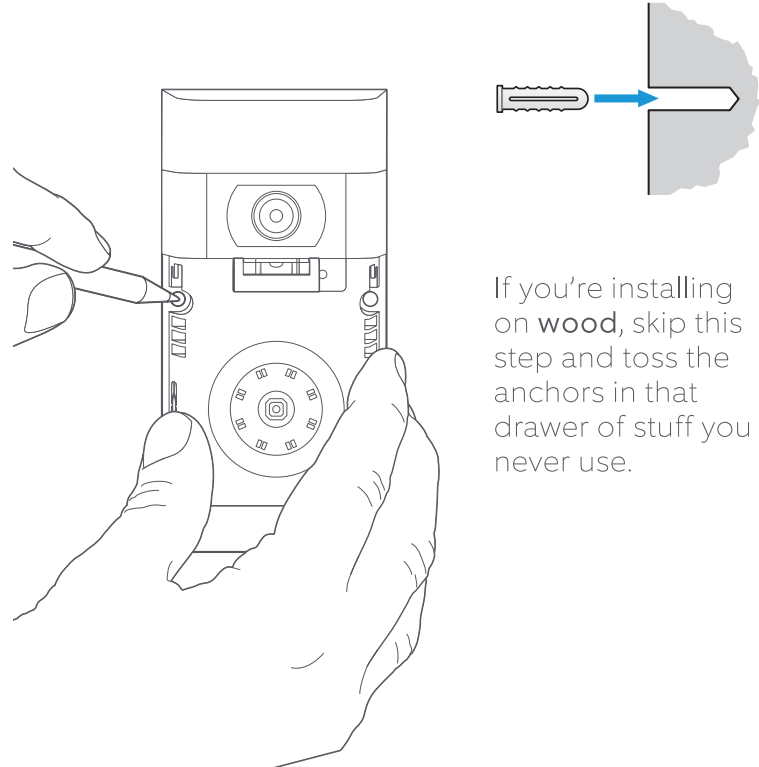

If you're installing on **wood**, skip this step and toss the anchors in that drawer of stuff you never use.

Connect the Wires (optional)

Connect the wires coming out of your wall to the screws on the back of your Ring Doorbell.

Either wire can connect to either screw. The order doesn't matter.

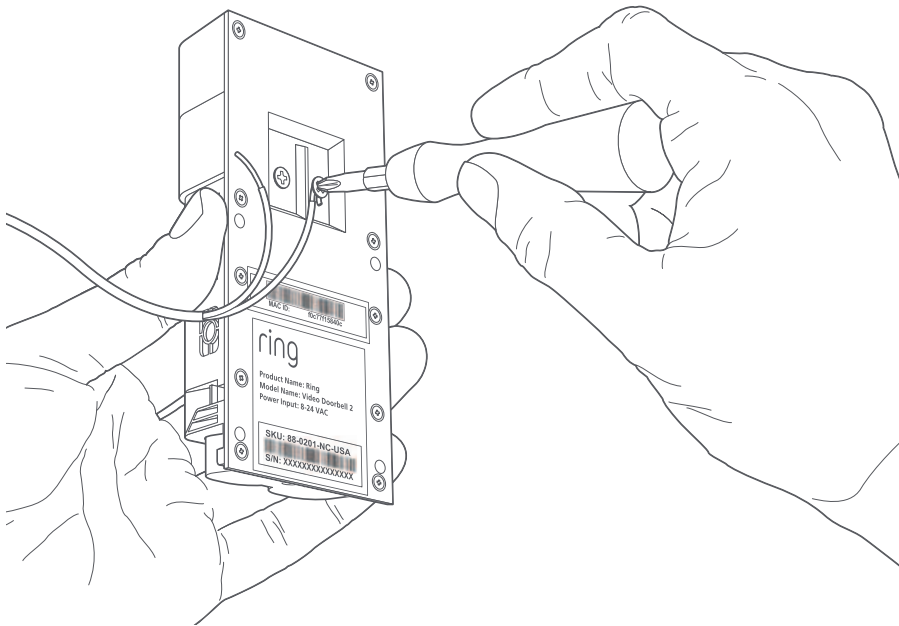

Attach the wire extensions (optional)

If you have trouble connecting the wires coming out of your wall to the back of your Ring Doorbell, use the provided wire extensions and wire nuts.

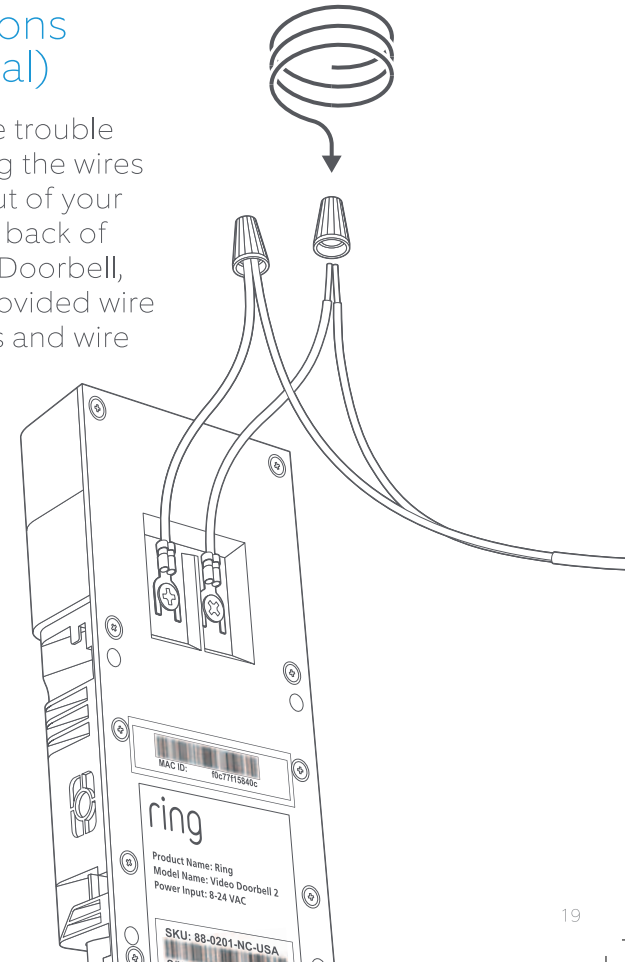

Screw it in

Feed all the wires (and the wire nuts, if you used them) into your wall and secure your Ring Doorbell on the wall using four screws.

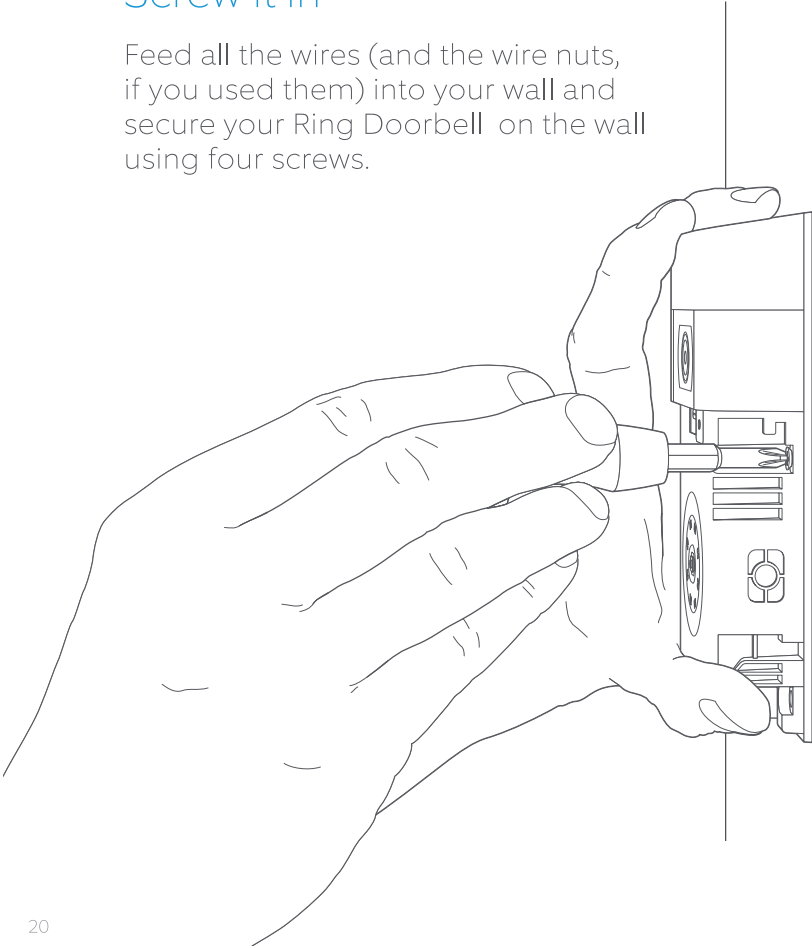

Install the faceplate

Place one of the provided faceplates on your Ring Doorbell by slotting it in at the top and clicking it into place.

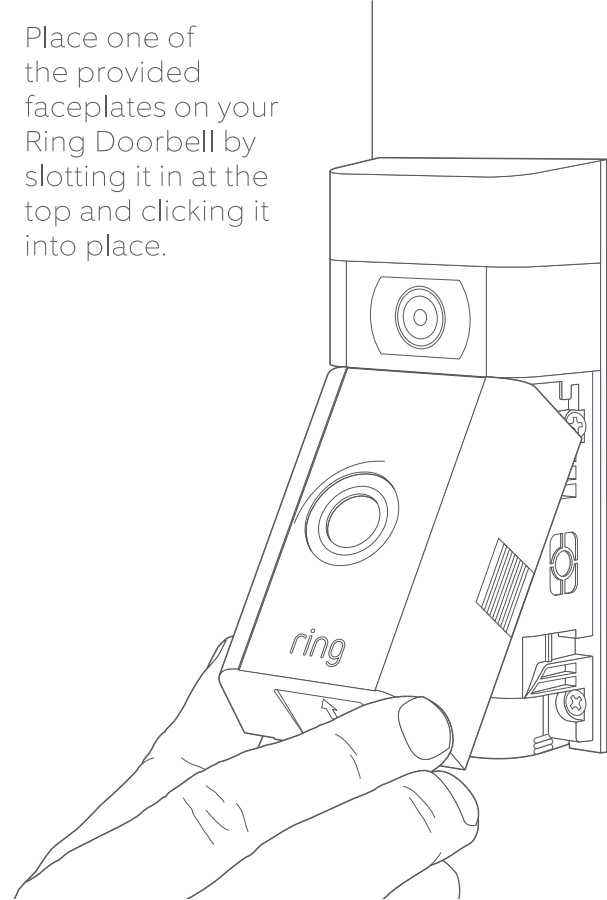

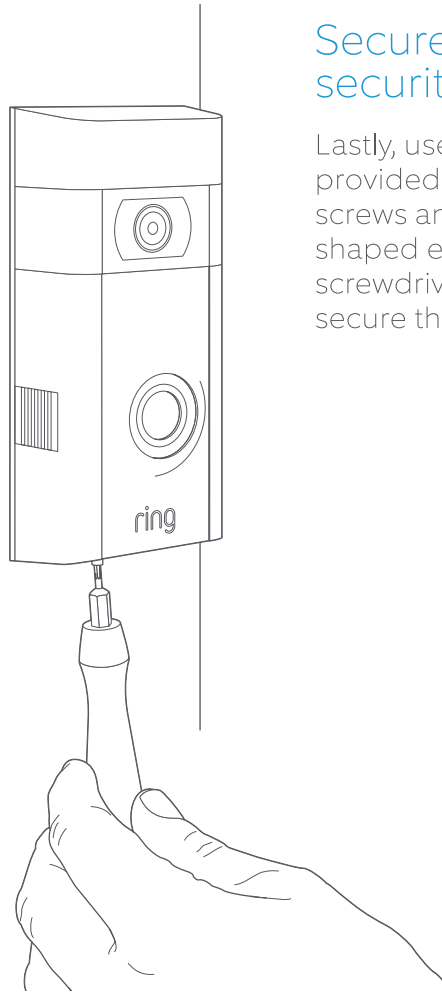

Secure with a security screw

Lastly, use one of the provided security screws and the star-shaped end of the screwdriver bit to secure the faceplate.

4. Check out all the exciting features.

After setting up your Ring Doorbell in the app, select it

This will bring you to the Device Dashboard, where you can change settings and access various features.

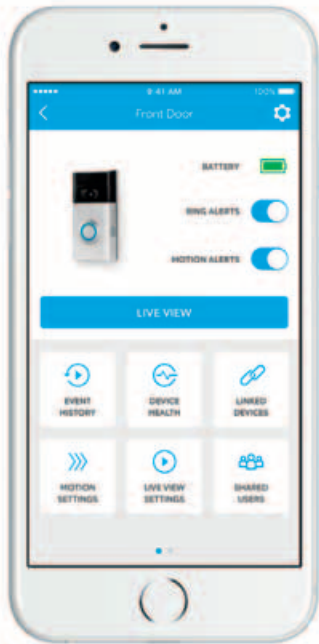

Ring Alerts are notifications you receive when someone presses the button on the front of your Ring Doorbell.

Motion Alerts are notifications you receive when movement is detected within your Motion Zones.

Switch these alerts on or off on this screen.



Shared Users

Select **Shared Users** to let family or friends answer live events and view recordings (if recording is enabled).



Motion Settings

Select **Motion Settings** to enable and customize your motion detection settings.



Device Health

Visit **Device Health** to diagnose any problems you run into with your Ring Doorbell.







Event History

View a log of all the events captured by your Ring Doorbell in **Event History**.

Answering your door



When someone is at your door, you can access these features:

-  **Two-way Talk** – Speak to visitors and hear what they have to say.
-  **Microphone** – Mute or unmute your mic.
-  **Speaker** – Mute or unmute audio in the app.
-  **Ring Neighborhoods** – Share suspicious events with your neighbors.

Ring Video Recording



This optional feature saves recordings of every event your Ring Doorbell captures.

You can access these events on any device running the Ring app or by logging into your account at: ring.com/activity

Learn more at: ring.com/video-recording

 Your new Ring Doorbell includes a free trial of Ring Recording for you to enjoy. Watch your email inbox for important announcements about this service.

5. Having trouble?

Here are some answers...

I'm having trouble completing the in-app setup

When the in-app setup fails, look at the front of your Ring Doorbell. The light indicates the issue.



Top Flashing White means your Wi-Fi password was entered incorrectly. Select your Wi-Fi network in your phone settings, select the option to forget it, then reconnect to it again to confirm that you're using the correct password during setup.



Right Flashing White means your Ring Doorbell may be too far from your router to get a decent signal. Repeat setup in the same room as your router. If this works, then you may need to get a Chime Pro to boost the Wi-Fi signal to your Ring Doorbell.

Learn more at: ring.com/chime-pro.



Left Flashing White indicates a possible issue with your internet connection. Unplug your modem or router for 40 seconds, plug it back in and then repeat the setup process.



Spinning White indicates that your Ring Doorbell is in setup mode. You'll need to follow the instructions in the Ring app. When prompted, connect to the Wi-Fi network being broadcast by your Ring Doorbell.



Nothing In this case, repeat setup and note the resulting pattern. If the front light never does anything, then you likely need to charge the battery.

Why can't I find the temporary Ring network on my phone?

Sometimes your phone fails to pick up the temporary Ring network. If this happens, go to your phone settings, turn off your Wi-Fi connection, wait 30 seconds and turn it back on. If the Ring network still fails to appear, ensure that the battery in your Ring Doorbell is fully charged.

If none of the above helped...

Perform a hard reset on your Ring Doorbell by holding down the setup button for 15 seconds, waiting 30 seconds and repeating the setup process.

Turn off cellular data and bluetooth on your mobile device and try again.

Try performing setup **on a different mobile device.**

Why isn't my internal doorbell ringing properly when someone presses the button on my Ring?

Make sure the circular light on the front of your Ring is glowing white to confirm that it's wired correctly.

If your internal doorbell is digital (which means it produces a synthesized melody), make sure you installed the provided **diode**.

If you have installed the **diode**, it may be installed backwards. Simply reverse the wiring on the back of your Ring Doorbell and press the front button again.

If your internal doorbell is mechanical (which means it has a physical bell and makes a classic "ding dong" sound), then make sure you **didn't** install the diode.

Visit ring.com/diode for installation assistance.

Why can't visitors hear me on my Ring when I talk through the app?

If you're on an **iPhone or iPad**, check the microphone permission on your device. Select Settings, find Ring and select it. Lastly, make sure the switch next to Microphone is toggled on.

If you're on an **Android** device, go to Settings > Application/Apps > Application Manager > Ring > Permissions. Ensure everything here is on.

If you don't see the Microphone option, then uninstall and reinstall the Ring app. When prompted to allow microphone access, choose "Allow."

I'm not receiving motion alerts

First make sure you've configured **Motion Detection**, and that **Motion Alerts** are turned on (see pg. 24).

To further troubleshoot issues with not receiving notifications, select **Device Health** in the Ring app and then select **Troubleshoot Notifications**.

Why is my video and/or audio quality poor?

First, determine the cause. Remove your Ring Doorbell and bring it inside near your router. Press the front button on your Ring Doorbell and look at the video in the Ring app.

If you get good video quality near the router, you need to extend your Wi-Fi signal.

We recommend **Chime Pro** to boost the signal to your Ring Doorbell. Learn more at: ring.com/chime-pro.

If video quality is still poor near your router, test your internet speed by selecting **Device Health** in the Ring app, then **Test Your Wi-Fi**.

The instructions in the app will help you diagnose and solve any issues related to poor video quality.

This device complies with Part 15 of the FCC Rules. Operation is subject to the following two conditions: (1) this device may not cause harmful interference, and (2) this device must accept any interference received, including interference that may cause undesired operation.

For best results, use type Li-Ion batteries. Install only new batteries of the same type in your product. Failure to insert batteries in the correct polarity, as indicated in the battery compartment, may shorten the life of the batteries or cause batteries to leak. Do not mix old and new batteries. Do not mix Alkaline, Standard (Carbon-Zinc) or Rechargeable (Nickel Cadmium) or (Nickel Metal Hydride) batteries. Do not dispose of batteries in fire. Batteries should be recycled or disposed of as per state and local guidelines.

Warning: Changes or modifications to this unit not expressly approved by the party responsible for compliance could void the user's authority to operate the equipment.

NOTE: This equipment has been tested and found to comply with the limits for a Class B digital device, pursuant to Part 15 of the FCC Rules. These limits are designed to provide reasonable protection against harmful interference in a residential installation. This equipment generates, uses and can radiate radio frequency energy and, if not installed and used in accordance with the instructions, may cause harmful interference to radio communications.

However, there is no guarantee that interference will not occur in a particular installation. If this equipment does cause harmful interference to radio or television reception, which can be determined by turning the equipment off and on, the user is encouraged to try to correct the interference by one or more of the following measures:

Reorient or relocate the receiving antenna.

Increase the separation between the equipment and receiver.

Connect the equipment into an outlet on a circuit different from that to which the receiver is connected.

Consult the dealer or an experienced radio/TV technician for help.

CE 0682 Hereby, Bot Home Automation, declares that this consumer electronic is in compliance with the essential requirements and other relevant provisions of Directive 1999/5/EC. The declaration of conformity may be consulted at www.ring.com/DoC.pdf.

Protect the device from direct sunlight. Install the device at dry locations and protect it against rain and humidity. The device may not get contact to salt water or other conductive liquids. The device must be charged only within a building in a dry state.

© 2016 Bot Home Automation, Inc.

RING, ALWAYS HOME, and CHIME are trademarks of Bot Home Automation, Inc.

Ring Video Doorbell is patent pending.

Last updated: 08/17/18 FCC Radiation Exposure Statement

FCC Radiation Exposure Statement:

This device has been evaluated to meet general RF exposure requirement. The device can be used in portable exposure condition without restriction.

(More condition words in grey field to Canada.)

Canada Statement

This device complies with Industry Canada's licence-exempt RSSs. Operation is subject to the following two conditions:

- (1) This device may not cause interference; and
- (2) This device must accept any interference, including interference that may cause undesired operation of the device.

Le présent appareil est conforme aux CNR d'Industrie Canada applicables aux appareils radio exempts de licence. L'exploitation est autorisée aux deux conditions suivantes :

- (1) l'appareil ne doit pas produire de brouillage;
- (2) l'utilisateur de l'appareil doit accepter tout brouillage radioélectrique subi, même si le brouillage est susceptible d'en compromettre le fonctionnement.

ISED Radiation Exposure Statement:

This EUT is in compliance with SAR for general population/uncontrolled exposure limits in IC RSS-102 and has been tested in accordance with the measurement methods and procedures specified in IEEE 1528.

Declaration d'IC relative à l'exposition aux radiations:

Cet appareil est conforme aux spécifications DAS (Débit d'absorption spécifique) relatives aux limites générales d'exposition pour la population/dans les environnements non contrôlés, définies dans la norme IC RSS-102, et a été testé selon les méthodes de mesure et les procédures spécifiées dans la norme IEEE 1528.

For extremity operation, this device has been tested and meets the IC RF exposure guidelines for use with an accessory that contains no metal. Use of other accessories may not ensure compliance with IC RF exposure guidelines.

Pour le fonctionnement des extrémités, cet appareil a été testé et répond aux directives d'IC d'exposition pour une utilisation avec un accessoire ne contenant pas de métal. L'utilisation d'autres accessoires peut ne pas garantir la conformité avec les directives d'IC d'exposition.

LIMITED WARRANTY AND PURCHASE PROTECTION FOR AUSTRALIA CONSUMERS

Our goods come with guarantees that cannot be excluded under the Australian Consumer Law. You are entitled to a replacement or refund for a major failure and compensation for any other reasonably foreseeable loss or damage. You are also entitled to have the goods repaired or replaced if the goods fail to be of acceptable quality and the failure does not amount to a major failure. Goods presented for repair may be replaced by refurbished goods of the same type rather than being repaired. Refurbished parts may be used to repair the goods.

WHAT THE WARRANTY COVERS

For a period of one year from the date of your purchase of the Ring Video Doorbell, any malfunction caused by defective parts or workmanship will be corrected at no charge to you. Please keep your dated sales receipt; it is required for all warranty requests.

WHAT THE WARRANTY DOES NOT COVER

Repair service, damage due to misuse, abuse, negligence, or casualty (e.g., fire), and batteries are not covered by this warranty. Unauthorized service or modification of the product or of any furnished component will void this warranty in its entirety. This warranty does not include reimbursement for inconvenience, installation, loss of use, or unauthorized service.

This warranty covers only the Ring Video Doorbell and is not extended to other equipment and components that a customer uses in conjunction with our products. Bot Home Automation, Inc.'s maximum liability under this warranty is, to the extent permitted by law, limited to the original purchase price of the Ring Video Doorbell. In addition, Bot Home Automation, Inc. reserves the right to request any product claimed defective to be returned to Bot Home Automation, Inc. for inspection.

TO THE EXTENT PERMITTED BY LAW, THIS WARRANTY IS EXPRESSLY IN LIEU OF ALL OTHER WARRANTIES, EXPRESS OR IMPLIED, INCLUDING ANY WARRANTY, REPRESENTATION OR CONDITION OF MERCHANTABILITY OR THAT THE PRODUCTS ARE FIT FOR ANY PARTICULAR PURPOSE OR USE, AND SPECIFICALLY IN LIEU OF ALL SPECIAL, INDIRECT, INCIDENTAL, OR CONSEQUENTIAL DAMAGES.

IN SO FAR AS SUCH WARRANTIES CANNOT BE DISCLAIMED, THE DURATION AND REMEDIES FOR SUCH WARRANTIES ARE LIMITED TO THE DURATION OF THIS EXPRESS WARRANTY AND REPAIR OR REPLACEMENT SHALL BE THE SOLE REMEDY OF THE CUSTOMER AND EXCEPT AS PROVIDED IN THIS WARRANTY AND TO THE MAXIMUM EXTENT PERMITTED BY LAW THERE SHALL BE NO LIABILITY ON THE PART OF BOT HOME AUTOMATION, INC. FOR ANY SPECIAL, INDIRECT, INCIDENTAL OR CONSEQUENTIAL DAMAGES, INCLUDING BUT NOT LIMITED TO ANY LOSS OF BUSINESS OR PROFITS, WHETHER OR NOT FORESEEABLE.

To obtain the benefit of the above limited warranty, please contact us at:

Bot Home Automation, Inc.
1523 26th Street
Santa Monica, CA 90404
USA
1 300 205 983