

Precaution

Thank you for purchasing this digital instrument. For perfect operation and security, please read the manual carefully and keep it for future reference.

Safety Precautions



The lightning flash with arrowhead symbol within an equilateral triangle is intended to alert the user to the presence of uninsulated “dangerous voltage” within the product’s enclosure that may be of sufficient magnitude to constitute a risk of electric shock to persons.



The exclamation point within an equilateral triangle is intended to alert the user to the presence of important operating and maintenance (servicing) instructions in the literature accompanying the product.

Important Safety Instructions



(Figure 1)

- 1) Read these instructions.
- 2) Keep these instructions.
- 3) Heed all warnings.
- 4) Follow all instructions.
- 5) Do not use this apparatus near water.
- 6) Clean only with dry cloth.
- 7) Do not block any ventilation openings, install in accordance with the manufacturer’s instructions.
- 8) Do not install near any heat sources such as radiators, heat registers, stoves, or other apparatus (including amplifiers) that produce heat.
- 9) Do not defeat the safety purpose of the polarized or grounding-type plug. A polarized plug has two blades with one wider than the other. A grounding type plug has two blades and a third grounding prong. The wide blade or the third prong are provided for your safety, if the provided plug does not fit into your outlet, consult an electrician for replacement of the obsolete outlet.
- 10) Protect the power cord from being walked on or pinched particularly at plugs, convenience receptacles, and the point where they exit from the apparatus.
- 11) Only use attachments/accessories specified by the manufacturer.
- 12) Use only with the cart, stand, tripod, bracket, or table specified by the manufacturer, or sold with the apparatus. When a cart is used, use caution when moving the cart/apparatus combination to avoid injury from tip-over (Figure 1).
- 13) Unplug this apparatus during lightning storms or when unused for a long periods of time.
- 14) Refer all servicing to qualified service personnel. Servicing is required when the apparatus has been damaged in any way, such as power-supply cord or plug is damaged, liquid has been spilled or objects have fallen into the apparatus, the apparatus has been exposed to rain or moisture, does not operate normally, or has been dropped.

WARNING: To reduce the risk of fire or electric shock, do not expose this apparatus to rain or moisture.

CAUTION: Apparatus shall not be exposed to dripping or splashing and no objects filled with liquids, such as vases, shall be placed on the apparatus.

FCC warning statement

§ 15.19 Labelling requirements.

This device complies with part 15 of the FCC Rules. Operation is subject to the following two conditions: (1) This device may not cause harmful interference, and (2) this device must accept any interference received, including interference that may cause undesired operation.

§ 15.21 Information to user.

Any Changes or modifications not expressly approved by the party responsible for compliance could void the user's authority to operate the equipment.

§ 15.105 Information to the user.

Note: This equipment has been tested and found to comply with the limits for a Class B digital device, pursuant to part 15 of the FCC Rules. These limits are designed to provide reasonable protection against harmful interference in a residential installation. This equipment generates uses and can radiate radio frequency energy and, if not installed and used in accordance with the instructions, may cause harmful interference to radio communications. However, there is no guarantee that interference will not occur in a particular installation. If this equipment does cause harmful interference to radio or television reception, which can be determined by turning the equipment off and on, the user is encouraged to try to correct the interference by one or more of the following measures:

- Reorient or relocate the receiving antenna.
- Increase the separation between the equipment and receiver.
- Connect the equipment into an outlet on a circuit different from that to which the receiver is connected.
- Consult the dealer or an experienced radio/TV technician for help.

Thanks For Using Our Digital Piano

Your digital piano is a high-quality digital piano with 88 standard touch sensitivity keyboard and combines the most advanced PCM tone generation technology. This digital piano lets you record your performances and Registration settings to a USB Disk. Each user song lets you record up to sixteen independent tracks. In order to obtain maximum performance and enjoyment, please read this manual thoroughly while trying out the various features described.

Contents

Panel Control	3	Auto Accompaniment Control	
Connectors	4	30
Using AC Power Jack	4	Straight Start	30
Using Headphones	4	Synchro Start	30
Using Foot Pedals	5	Starting the Accompaniment with an	
Using MIDI IN/OUT Jack	6	Introduction	30
Using Line IN/OUT Jack	7	Adding Fill-In	31
Using USB-MIDI	7	Stopping the Accompaniment	31
Basic Operation	8	Variation	31
Power Switch	8	Fade	32
Adjust the Volume	8	Harmony	32
Demo Play	8	Chord Function	32
Tempo	10	User Style	35
Tap/Tempo	10	Registration Memory	37
Transpose	10	Memorizing the Settings	37
Tune	11	Recalling the Settings	38
Reverb	11	Saving the Registration Data to	
Adjusting Reverb Depth	12	USB Disk	38
Chorus	12	Use Registration Data from USB	
Adjusting Chorus Depth	12	39
Metronome	13	Delete REG File from USB	39
Sustain	13	Song Recording	40
Touch	14	Quick Recording	40
Function	15	Multi Track Recording	42
Voices	22	Delete Song	45
Selecting a Voice	22	File Button	46
Dual Mode	23	Filter Button	46
Split Mode	24	Adjusting Song's Volume	47
Adjusting Keyboard Volume		Factory Set	48
.....	25	Appendix	49
Playing Portable Grand Piano		Voice List	49
.....	26	Style List	50
One Touch Setting	26	Percussion Voice List	51
Twin Mode	26	MIDI Implementation Chart	52
Auto Accompaniment	27	Specifications	53
Using Auto Accompaniment		Assembly Instructions	54
(Only Rhythm Track)	27		
Using Auto Accompaniment			
(All Tracks)	28		

Panel Contents

1. POWER
 2. VOLUME CONTROLS
 - MASTER VOLUME
 - RHYTHM
 - BASS/CHORD
 3. MULTI DISPLAY
 4. [◀ TRANS ▶] Button
 5. [◀ TUNE ▶] Button
 6. [◀ KB.VOL ▶] Button
 7. [◀ TEMPO ▶] Button
 8. [TAP/TEMPO] Button
 9. [O.T.S] Button
 10. [METRO] Button
 11. [REVERB] Button
 12. [CHORUS] Button
 13. [SUSTAIN] Button
 14. [CHORD] Button
 15. [FADE] Button
 16. [SYNCHRO] Button
 17. [START/STOP] Button
 18. [INTRO/ENDING] Button
 19. [FILL IN] Button
 20. [VARIATION] Button
 21. [SPLIT] Button
 22. [HARMONY] Button
 23. [DUAL] Button
 24. [TWIN] Button
 25. [FUNCTION] Button
 26. [ENTER] Button
 27. [TOUCH] Button
 28. [VOICE] Button
 29. [STYLE] Button
 30. [GRAND PIANO] Button
 31. Number Buttons [0]-[9]
 - [+] and [-] Buttons
 32. [LEFT] Button
 33. [RIGHT] Button
 34. [DEMO] Button
 35. [STORE/BANK] Button
 36. [SAVE] Button
 37. [M1-M6] Button
 38. [FILE] Button
 39. [RECORD] Button
 40. [PLAY/LOAD] Button
 41. [TRACK] Button
 42. [FILTER] Button
 43. [USB.VOL] Button
 44. [USB]
- Rear Panel**
45. [MIDI OUT] Jack
 46. [MIDI IN] Jack
 47. [PEDAL] Jack
 48. [USB] Jack
 49. [LINE OUT] Jack
 50. [LINE IN] Jack
 51. [POWER] Jack
 52. [PHONES1] Jack
 - [PHONES2] Jack

Connectors

Using AC Power Jack

Connect the power cable to the AC power jack on the rear panel of the piano body.

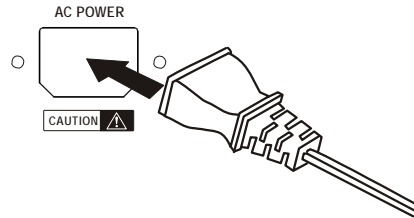

Plug the power cable into an AC power outlet.

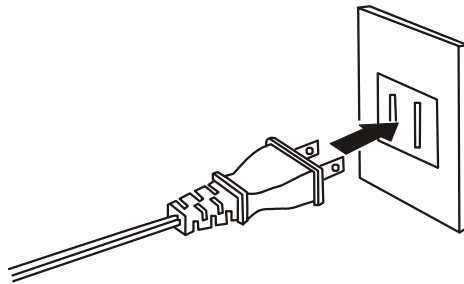

Caution

- 1. Ensure the piano is turned off when connecting and disconnecting the power.*
- 2. Turn the volume switch to reach the minimum level before turning on the power*

Using Headphones

Two sets of standard stereo headphones can be plugged in here for private practice or late-night playing. The internal speaker system is automatically shut off when a pair of headphones is plugged into PHONES jacks.



Using Foot Pedals

Connect the plug of the foot pedal unit to the pedal jack on the rear panel.

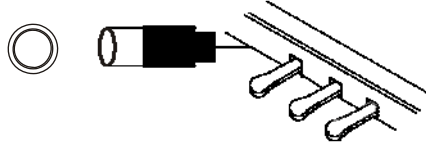

1. Damper Pedal (Right)

It performs the same function as the damper pedal on an actual acoustic piano, letting you sustain the sound of the voices even after releasing your fingers from the keys.

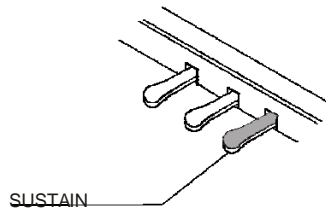

2. Sostenuto Pedal (Center)

If you play a note or chord on the keyboard and press the sostenuto pedal while the notes are held, those notes will be sustained as long as the pedal is held, but all subsequently played notes will not be sustained.

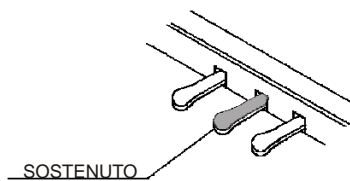

3. Soft Pedal (Left)

The Soft Pedal controls the sound volume. Press the pedal to decrease the output sound volume.

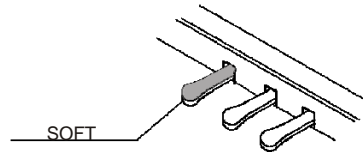

Using MIDI IN/OUT Jack

MIDI (Musical Instrument Digital Interface) is a world-standard communication interface which allows electronic musical instruments to communicate with each other, by sending and receiving compatible note, program change and other types of MIDI data.

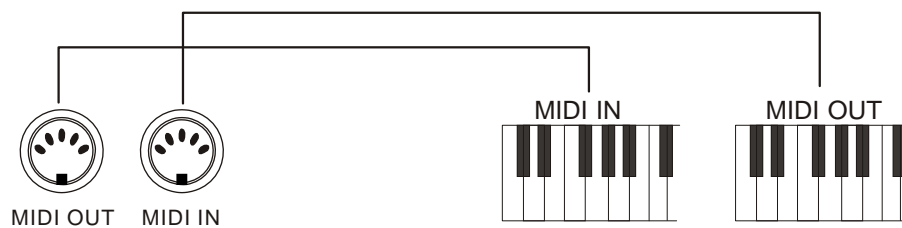

NOTE

MIDI IN Receives MIDI data from another MIDI device.

MIDI OUT Transmits MIDI data to another MIDI device.

Using Line IN/OUT Jack

The audio output from other sound system connected to the LINE IN jack on the rear panel can be mixed with the sound of the unit. This function is convenient when you want to play along with a favourite song.

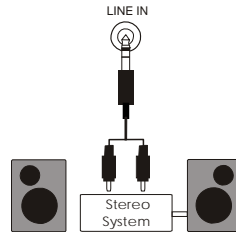

The Line out jack can be used to deliver the output of the piano to a keyboard amplifier, stereo sound system, mixing console or tape recorder.

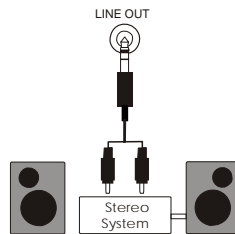

Using USB-MIDI

This product allows the transfer of MIDI over USB. There is a specific way in which the MIDI signals are routed for maximum flexibility. In a standard Digital Piano, the built-in keyboard sends MIDI signals to the internal sound bank as well as the 5-pin MIDI output. In this digital piano, the keyboard not only sends MIDI to the internal sound bank (just like normal) but also sends MIDI simultaneously to the internal MIDI connection which hooks up inside the device to the Audio Interface.

It is the Audio Interface that controls the USB-MIDI.

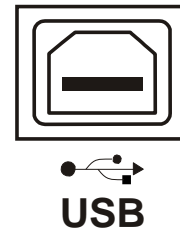

NOTE

USB DISK Can not be used while using USB-MIDI Function

Basic Operation

Power Switch

Turn the power on by pressing the [POWER] switch, the panel LCD display will light.



Adjust the Volume

Use [MASTER VOLUME] control to adjust the volume to your desired level.

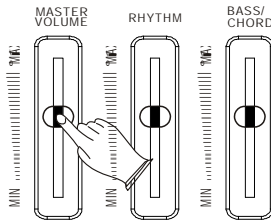

Demo Play

There are 3 preset piano songs that you can play individually. Here's how you can select and play the demo songs .

1. Listen to the Demo Song

Press [DEMO] button to play the demo songs in sequence. Use [+] and [-] buttons or number [1-3] to select the number of the song you want to play.

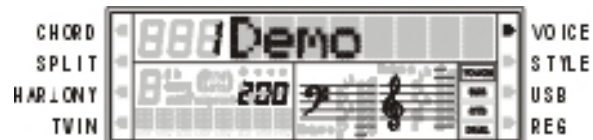
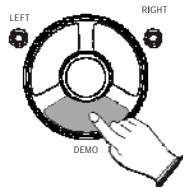

2. Stop Playing

Press [DEMO] button again to stop playing.

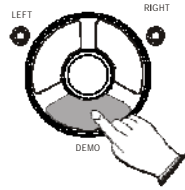

3. Adjust Demo Song's Volume

Each song has two tracks performance (left hand and right hand). You can use [RHYTHM] control to adjust left hand volume, and use [BASS/CHORD] control to adjust right hand volume.

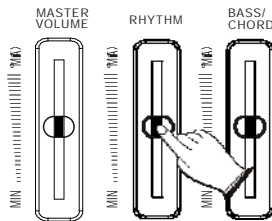

While the demo song is playing, you can deactivate the corresponding track by pressing the [LEFT] or [RIGHT] button.

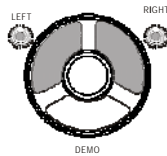

4. Adjust the Tempo of the Demo Song

When a demo song is playing, you can adjust its tempo by pressing the [TEMPO ◀/▶] buttons.

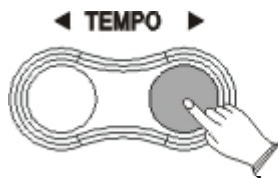

Tempo

Press the [TEMPO ◀] or [TEMPO ▶] button to decrease or increase the tempo of songs, metronome and styles.

Range: 20-280.

Press [TEMPO ◀] and [TEMPO ▶] button simultaneously to reset the tempo to default value.

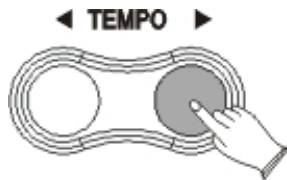

Tap/Tempo

This function allows you to set the rhythm tempo by tapping in tempo on [TAP/TEMPO] button. Tap on the button 2 times while rhythm is playing, The rhythm tempo are set as your desired speed.

If you want to set the tempo before starting rhythm, you have to tap the button 4 times.



Transpose

The Transpose function allows you to change the pitch of the instrument in semitone steps, up to a maximum setting of 12 semitones (a maximum of one octave up or down).

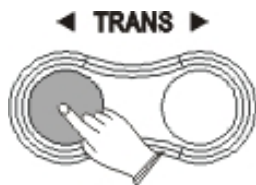

Use [TRANS◀/▶] button to transpose up or down as required. The transposition range is from “-12” (down one octave) through “0” (normal pitch) to “12” (up one octave).

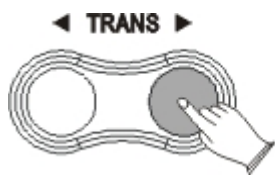

Tune

This function makes it possible to tune the pitch of your instrument to match other instruments. The tune range is from -64 (down one semitone) through “0” (normal pitch) to “63” (up one semitone).

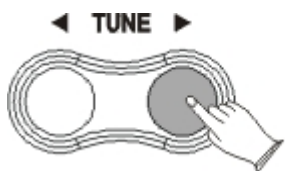

Reverb

The [REVERB] button selects a number of digital reverb effects that you can use for extra depth and expressive power.

Press [REVERB] button, use [+] and [-] buttons to select reverb type. No reverb is produced when you select “OFF”, and the indicator is off.



1	2	3	4	5	6	7	8
Room1	Room2	Room3	Hall1	Hall2	Plate	Delay	PanDelay

NOTE

Press [REVERB] button repeatedly to turn on or turn off the reverb effect.

Adjusting Reverb Depth

Reference: F2 Reverb and Chorus Depth(P.16).

Chorus

Shimmering, broadening effect. Press [CHORUS] button, use [+] and [-] buttons to select chorus type. No chorus is produced when you select 'OFF', and the indicator is off.

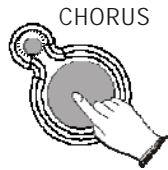

The chorus types in the list below can be selected from the chorus display.

1	2	3	4	5	6	7	8
Chorus1	Chorus2	Chorus3	Chorus4	Feedback	Flanger	ShtDelay	FbDelay

NOTE

Press [CHORUS] button repeatedly to turn on or turn off the chorus effect.

Adjusting Chorus Depth

Reference: F2 Reverb and Chorus Depth(P.16).

Metronome

Metronome is a convenient feature for practice, and it can also provide a solid rhythmic guide when recording.

The metronome sound is alternately turned on and turned off by pressing [METRO] button.

The time signature of the metronome can be set by using [+] and [-] buttons while turning on the metronome function.

Time signature: 1/4, 2/4, 3/4, 4/4, 6/4, 3/8, 6/8, 9/8.



To set the tempo of metronome, please see the details in **TEMPO** section(P.10).

Sustain

Press [SUSTAIN] button so that its icon appears to turn sustain on. It can be used as a damper pedal. Turning sustain on to sustain notes after the keys are released.

Press [SUSTAIN] button again to turn sustain off.



Touch

The touch function provides four different types of keyboard touch sensitivity that can be selected to match different playing styles.

Press the [TOUCH] button, use [+] and [-] buttons to select the touch sensitivity type in the range of 00 to 03. Default: 02 .



No	Name	Description
00	Fixed	means that regardless of how hard you play, the keyboard will transmit a velocity value of 100.
01	Hard	is defined as a curve which makes it easier to play quietly. The curve generates lower velocities for the same force
02	Normal	is defined as a curve which will be mid-way between the other two.
03	Soft	is defined as a curve which makes it easier to play loudly. The curve generates higher velocities for the same force.

Function

The [FUNCTION] button provides access to a range of functions that give your instrument extraordinary versatility. The functions are categorized in groups as follows:

- F1** Pan
- F2** Reverb and Chorus Depth
- F3** Octave
- F4** Split and Chord Point
- F5** MIDI Reception and Transmission
- F6** Local Control
- F7** Auto Track

Press [FUNCTION] button repeatedly to select desired function: F1 through F7



F1 Pan

In this function you can set the stereo position of each orchestration part to create a board stereo image of your sound.

Press [FUNCTION] button to select “M. PAN?”, Use [+] and [-] buttons to select “S. PAN?” and “D .PAN?” .



M .PAN-----Main Voice Pan
 S. PAN-----Split Voice Pan
 D. PAN-----Dual Voice Pan

Press [ENTER] button to confirm, and use [+] and [-] buttons to set the pan value: From -64(Left) to 63(Right).



F2 Reverb and Chorus Depth

In this function you can adjust the reverb and chorus depth for the selected voice.
 Press [FUNCTION] button to select “M. RevVo?” , Use [+] and [-] buttons to select “S. RevVo?” , “ D. RevVo?” , “M. ChrVo?” , “S. ChrVo?” , “ D. ChrVo?”



M. RevVo?-----Main Voice Reverb Depth
 S. RevVo?----- Split Voice Reverb Depth
 D. RevVo?----- Dual Voice Reverb Depth
 M. ChrVo?----- Main Voice Chorus Depth
 S. ChrVo?----- Split Voice Chorus Depth
 D. ChrVo?----- Dual Voice Chorus Depth

Press [ENTER] button to confirm, use [+] and [-] buttons or number buttons (0-9) to adjust the value: 00-63

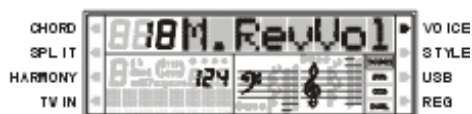

F3 Octave

Press [FUNCTION] button to select “M. Octav?” , Use [+] and [-] buttons to select “S. Octav? and D. Octav?” .



M. Octav?-----Main Voice Octave
 S. Octav?----- Split Voice Octave
 D. Octav?----- Dual Voice Octave

Press [ENTER] button to confirm, and use [+] and [-] buttons to set the octave value: -2 to 2



F4 Split and Chord Point

In this section, you can set the split or chord point when your keyboard is in Split or Chord mode.

Press [FUNCTION] button to select “S. Point?”, and use [+] and [-] buttons to select “C. Point?”.



S. Point?-----Split Point
C. Point?-----Chord Point

Press [ENTER] button to confirm, use [+] and [-] buttons or number buttons (0-9) to set the point. Range: 00-87.

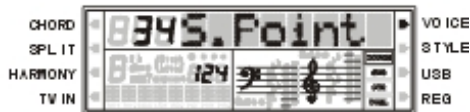

F5 MIDI Reception and Transmission

In this function, you can select MIDI reception and transmission track, and turn on or turn off MIDI IN and MIDI OUT function.

Press [FUNCTION] button to select “MIDI R0?”, Use [+] and [-] buttons to select “MIDI R1 ?, MIDI S0 ?, MIDI S1 ?, MIDI S2 ?, MIDI S3 ?”.

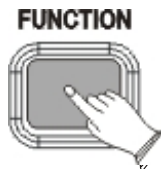

MIDI R0-----Reception Disabled
 MIDI R1-----Reception Enabled
 MIDI S0-----Transmission Off
 MIDI S1-----Selecting Main Voice Ch
 MIDI S2-----Selecting Split Voice Ch
 MIDI S3-----Selecting Dual Voice Ch

Press [ENTER] to confirm, and use [+] and [-] buttons to set the parameters.



NOTE

When selecting “MIDI S1-S3” mode, the transmission is enabled automatically, and use [+/-] button or number buttons to select MIDI channel(1-16) for which you want to specify a new transmission.

F6 Local Control

In this function, you can turn on or turn off the speaker system of your piano.

Press [FUNCTION] button to select “Local ?”

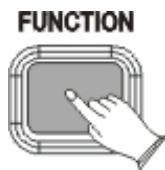

Press [ENTER] button to confirm, use [+] and [-] buttons to select “Local on” or “local off” .



Local on----- Normal operation. Keyboard and Controllers are sent to the Sound Engine.

Local off----- There will be no sound produced by the brain's tone generator. MIDI function can work as usual.

Auto Track

Here you can turn on or turn off AUTO TRACK function for recording mode. And the setting will be saved automatically when the power is off.

Press [FUNCTION] button to select “AutoTrk?”

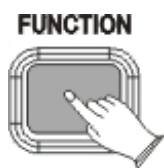

Press [ENTER] button to confirm, and use [+] and [-] buttons to select “OnAutoTrk” and “OffAutoTrk” .



OnAutoTrk-----when you want to record more tracks data, select “OnAutoTrk” , the piano brain will assign the next track for you automatically.

OffAutoTrk-----when you want to select tracks by yourself, here you have to select “OffAutoTrk” function first, then press [TRACK] button on the panel to select the track you want.

Voices

Selecting a Voice

Your instrument has 128(01-128) GM standard voices. 10(129-138) different drum percussion kits and 1 set of sound effect that you can select and play.

Press [VOICE] button, the voice mode is selected and the current voice number and the name will display on the Message Display section.

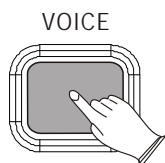

Use [+] and [-] buttons or number buttons [0-9] to select the desired voice according to the voice list.

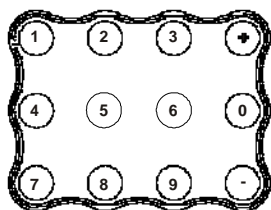

NOTE

When the keyboard is in Split or/and Dual mode, press [VOICE] button repeatedly can switch Main Voice Mode and Split Voice Mode or/and Dual Voice Mode.

Dual Mode

Press [DUAL] button to select layer voice mode, two voices will sound simultaneously when you play keyboards.

1. Select Dual Voice

Press [DUAL] button, Dual Cursor is flashing, use the number [0]-[9] or [+] and [-] buttons to select the second voice. If you don't choose the second voice within 4 seconds, the LCD Display will go back to the first voice mode.

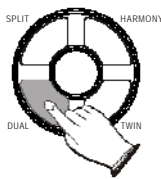

2. Setting the Dual Voice Volume

Reference: Adjusting Keyboard Volume(P.25).

NOTE

To change the dual voice Pan, Octave and Reverb/Chorus Depth, please see the details in [FUNCTION] section (P.15).

3. Exit the Dual Mode

Press [DUAL] again, the Dual Cursor turns off and the Dual mode is no longer active.

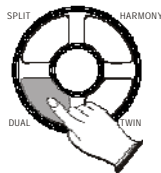

Split Mode

Press [SPLIT] button to select split mode, your keyboard will be split into two sections which means different voices can be played with the left and right hands at the same time.

1. Select Split Voice

Press [SPLIT] button, the Split cursor is flashing, and the split voice will appear in the message display for 4 seconds, and use [0-9] buttons to select the left voice.

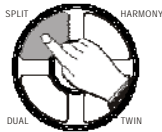

2. Changing the Split Point

Reference: F4 Split and Chord Point(P.18).

3. Setting the Split Voice Volume

Reference: Adjusting Keyboard Volume(P.25).

NOTE

To change the split voice Pan, Octave and Reverb/Chorus Depth, please see the details in [FUNCTION] section (P.15).

4. Exit the Split Mode

Press [SPLIT] again, the Split Cursor turns off and the Split mode is no longer active.

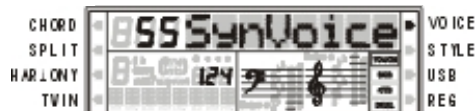
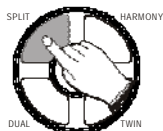

Adjusting Keyboard Volume

Use this function can adjust the Split Voice Volume, Dual Voice Volume and the Main Voice Volume.

1. Split Voice Volume

In Split mode, press [KB.VOL◀▶] button can adjust the split voice volume while the Split Cursor is flashing.

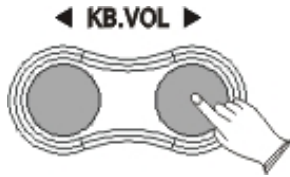

2. Dual Voice Volume

In Dual mode, press [KB.VOL◀▶] button can adjust the Dual voice volume while the Dual Cursor is flashing.

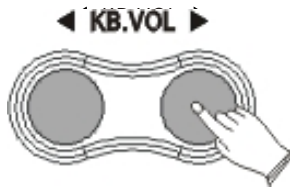

3. Main Voice Volume

You can adjust the main voice volume by pressing [KB.VOL◀▶] button when the Dual or Split Cursor does not flash.

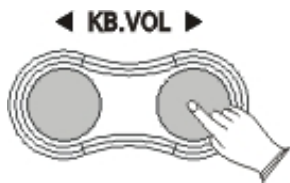

Playing Portable Grand Piano

Press [GRAND PIANO] button.

This convenient function lets you instantly call up the Grand Piano voice.

GRAND PIANO



One Touch Setting

This function is actually a convenient feature which automatically selects a suitable voice for you when you select a style. In addition, various panel settings (such as voice, effect, Tempo, etc.) that match the selected style can be recalled with just a single button [O.T.S].

Press [O.T.S] button repeatedly can turn on or turn off One Touch Setting.

O.T.S



Twin Mode

Press [TWIN] button to select Twin mode. In this mode, the keyboard will be separated into two play areas.

Right: from $\sharp C3$ to $C7$

Left: from $A-1$ to $C3$

Press [TWIN] button again to exit the Twin mode.

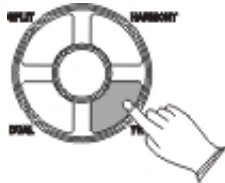

Auto Accompaniment

Your instrument has 100 accompaniment styles which can be used to provide Fully-orchestrated Auto Accompaniment. When the Auto Accompaniment function is turned ON, this instrument creates fully-orchestrated rhythm, bass and chord accompaniment based on chords you play with the left hand in the Auto Accompaniment section of the keyboard(i.e. all keys to the left of the Auto Accompaniment split point). The right-hand section of the keyboard is available for normal playing.

The default Auto Accompaniment split point is the #F2 key. The Auto Accompaniment section of the keyboard Consists of all keys to its left .

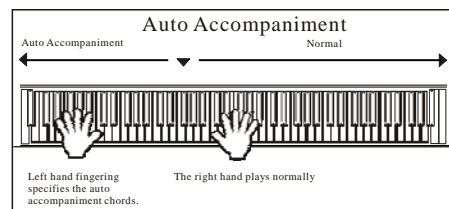

Using Auto Accompaniment (Only Rhythm Track)

1. Press the [STYLE] Button

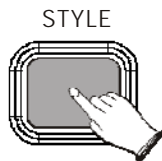

2. Selecting a Style

Using [+] and [-] buttons or number buttons [0-9].
When selecting style 100, holding the [1] button till the “1--” is displayed, then you can enter the tens and ones digits.

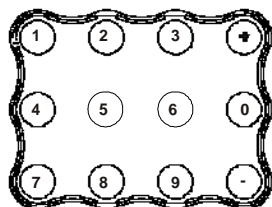

3. Start Playing the Style

Press [START/STOP] button to start the rhythm track of the Auto Accompaniment. Minus the bass and the chord tracks.

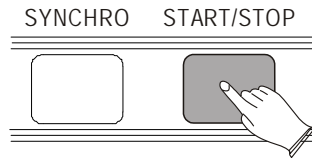

4. Stop Playing the Style

Press the [START/STOP] button again to stop the accompaniment.

Using Auto Accompaniment (All Tracks)

1. Press the [STYLE] Button

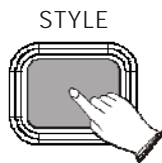

2. Selecting a Style

Using [+] and [-] buttons or number buttons [0-9].

When selecting style 100, holding the [1] button till the "1--" is displayed, then you can enter the tens and ones digits.

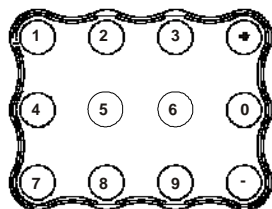

3. Turn the Chord Function On

Press the [CHORD] button

The left hand section of the keyboard becomes the Auto Accompaniment section, and chords played in this section are automatically detected and used as a basis for fully automatic accompaniment which the selected style.

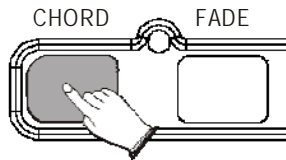

4. Turn On the Synchronized Start

Press [SYNCHRO] button

The beat lamp will flash in time with the tempo, it's called synchronized start standby. The auto accompaniment starts as soon as you play a chord with your left hand.

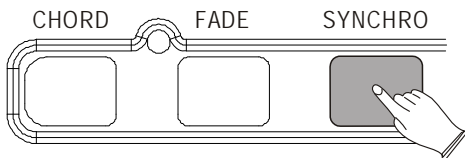

5. Stop Playing the Style

Press the [START/STOP] button again to stop the accompaniment.

Use RHYTHM volume control to adjust the rhythm volume of the Auto Accompaniment.

Use BASS/CHORD volume control to adjust the chord and bass volume of the Auto Accompaniment.

Auto Accompaniment Control

Straight Start

The [START/STOP] button starts the selected accompaniment style immediately. A different accompaniment style can be selected at any time while the accompaniment is playing.

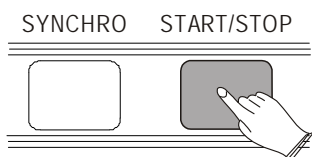

Synchro Start

Press the [SYNCHRO] button, then the accompaniment will start when you play the first chord on the AUTO ACCOMPANIMENT section of the keyboard.

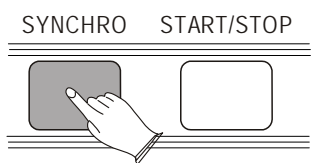

Starting the Accompaniment with an Introduction

Any of your instrument accompaniment patterns can be started with an appropriate introduction by pressing the [INTRO/ENDING] button directly.

If you press the [SYNCHRO] button and then press the [INTRO/ENDING] button, the accompaniment will start from the introduction as soon as a chord is detected in the AUTO ACCOMPANIMENT section of the keyboard.

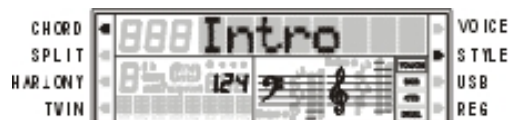
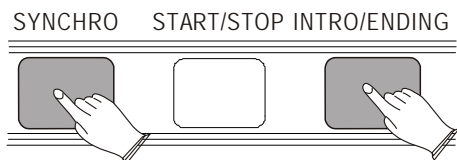

Adding Fill-In

Press the [FILL IN] button at any time while the accompaniment is playing to add a one-measure fill-in.

If you press the [SYNCHRO] button and then the [FILL IN] button, the accompaniment will start from the fill-in as soon as a chord is detected in the AUTO ACCOMPANIMENT section of the keyboard.

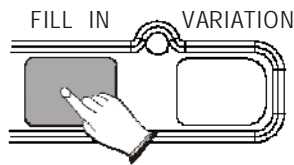

Stopping the Accompaniment

An accompaniment progress can be stopped immediately by pressing the [START/STOP] button and also can be stopped with an appropriate ending by pressing the [INTRO/ENDING] button.

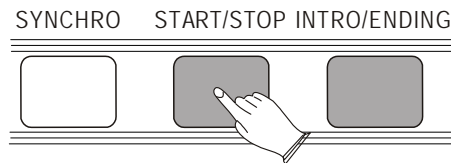

Variation

While the style is playing, you can add variation in the rhythm/accompaniment by pressing the [VARIATION] button. This switches between the Main A and Main B sections automatically playing a Fill-in pattern to smoothly lead into the next section.

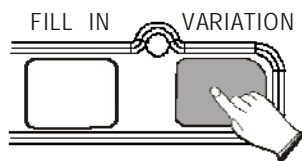

Fade

Press [FADE] button makes rhythm fade up when starting the rhythm.
While rhythm is playing, press [FADE] button to make rhythm fade away.

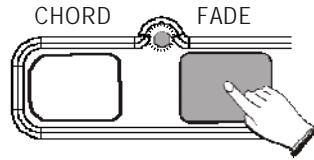

Harmony

The harmony function features a variety of performance effect that enhance the melodies you play when using the accompaniment styles.

Press [HARMONY] button, the Harmony Cursor appears on the display.

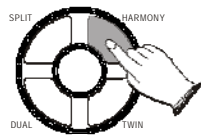

The Harmony is derived from the chords you have played if you use Automatic Accompaniment or turn on the Chord function.

Chord Function

Turn on this mode, the specified left-hand section of the keyboard becomes the “Auto Accompaniment” section, and chords played in this section are automatically detected and used as a basis for fully automatic accompaniment with the selected style

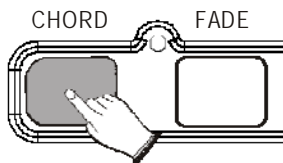

SINGLE Mode

SINGLE Mode fingering makes it simple to produce beautifully orchestrated accompaniment using major, seventh, minor and minor-seventh chords by pressing a minimum number of keys in the Auto Accompaniment section of the keyboard. The accompaniment produced is perfectly matched to the currently selected accompaniment style.

Major Chords

If you press a “C” key in the left-hand section of the keyboard, for example, a C-major accompaniment will be played. Press another key in the left hand section of the keyboard to select a new chord. The key you press will always determine the "root" of the chord played (i.e. “C” for a C chord).

Minor Chords

Simultaneously press the root key and a black key to its left.

Seventh Chords

Simultaneously press the root key and a white key to its left.

Minor-Seventh Chords

Simultaneously press the root key and both a white and black key to its left.

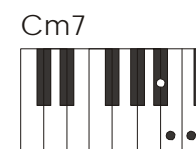
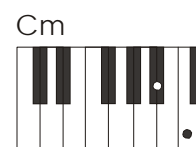

Fingered Mode

Fingered Mode is ideal if you already know how to play chords on a keyboard, since it allows you to supply your own chords for the Auto Accompaniment feature. The instrument will recognize the following chord type:

Name	Normal Voicing	Chord(C)	Display
[M]	1-3-5	C	C
[6]	1-(3)-5-6	C6	C6
[M7]	1-3-(5)-7or1-(3)-5-7	CM7	CM7
[M7#11]	1-(2)-3- \sharp 4-5-7 or 1-2-3- \sharp 4-(5)-7	CM7 \sharp 11	CM7(\sharp 11)
[Madd9]	1-2-3-5	CMadd9	C(9)
[M9]	1-2-3-(5)-7	CM9	CM7(9)
[6 9]	1-2-3-(5)-6	C6 9	C6(9)
[aug]	1-3- \sharp 5	Caug	Caug
[m]	1- \flat 3-5	Cm	Cm
[m6]	1- \flat 3-5-6	Cm6	Cm6
[m7]	1- \flat 3-(5)- \flat 7	Cm7	Cm7
[m7b5]	1- \flat 3- \flat 5- \flat 7	Cm7 \flat 5	Cm7 \flat 5
[madd9]	1-2- \flat 3-5	Cmadd9	Cm(9)
[m9]	1-2- \flat 3-(5)- \flat 7	Cm9	Cm7(9)
[m11]	1-(2)- \flat 3-4-5-(\flat 7)	Cm11	Cm7(11)
[mM7]	1- \flat 3-(5)-7	CmM7	CmM7
[mM9]	1-2- \flat 3-(5)-7	CmM9	CmM7(9)
[dim]	1- \flat 3- \flat 5	Cdim	Cdim
[dim7]	1- \flat 3- \flat 5-6	Cdim7	Cdim7
[7]	1-3-(5)- \flat 7 or 1-(3)-5- \flat 7	C7	C7
[7sus4]	1-4-(5)- \flat 7	C7sus4	C7sus4
[7 9]	1-2-3-(5)- \flat 7	C7 9	C7(9)
[7#11]	1-(2)-3- \sharp 4-5- \flat 7 or 1-2-3- \sharp 4-(5)- \flat 7	C7 \sharp 11	C7(\sharp 11)
[7 13]	1-3-(5)-6- \flat 7	C7 13	C7(13)
[7b9]	1- \flat 2-3-(5)- \flat 7	C7 \flat 9	C7(\flat 9)
[7b13]	1-3-5- \flat 6- \flat 7	C7 \flat 13	C7(\flat 13)
[7#9]	1- \sharp 2-3-(5)- \flat 7	C7 \flat 9	C7(\flat 9)
[M7aug]	1-(3)- \sharp 5-7	CM7aug	CM7aug
[7aug]	1-3- \sharp 5- \flat 7	C7aug	C7aug
[sus4]	1-4-5	Csus4	Csus4
[1+2+5]	1-2-5	C1+2+5	C

Example for “c” chords

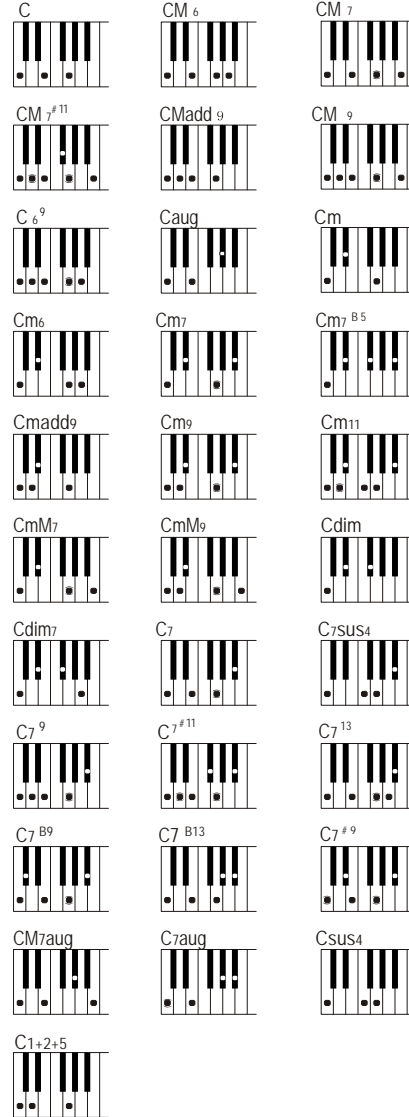

The chord fingerings listed are all in root position, but other inversions can be used with the following exceptions: 6, m6, sus4, aug, dim7, 6(9), m7(11), 1+2+5.

User Style

This digital piano can play RINGWAY Style(*.RTY) and YAMAHA Style(*.STY).

Copy the RINGWAY Style(*.RTY) or YAMAHA Style(*.STY) from computer to your USB Disk

Insert the USB Disk into the USB terminal.

Press [FILE] button, use [+] and [-] buttons to select RINGWAY Style (*.RTY) or YAMAHA Style (*.STY).

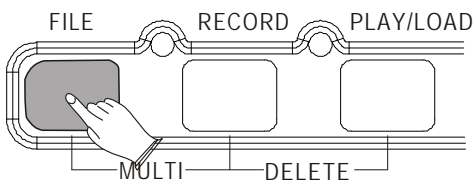

Press [PLAY/LOAD] button.

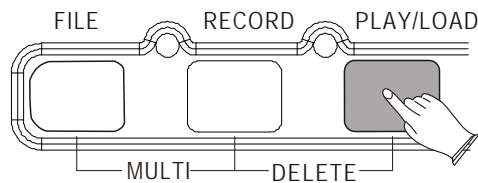

Press [STYLE] button, use number buttons to select “101 USER Rhy” .
Now the RINGWAY Style or YAMAHA Style can be used as usual by pressing Rhythm Control buttons.

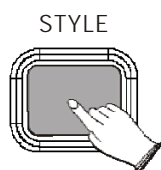

NOTE

Some YAMAHA Styles have four variations (Main A, Main B, Main C and Main D), only two variations (Main A and Main B) will be recognized by your instrument.

Only one User Style can be loaded once. And the User Style will be lost after playing MIDI file. You need to reload the User Style again when you want to use it.

Registration Memory

Your instrument registration memory can be used to store six sets of voice and auto accompaniment settings that can be recalled during you playing at the touch of one single button.

Memorizing the Settings

1. Select the Desired Bank

Press the [STORE/BANK] button repeatedly to select the bank [1MmryBank] -[4MmryBank].

STORE/BANK

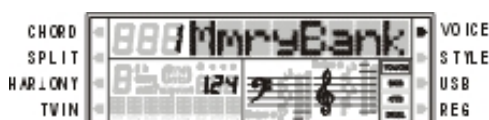
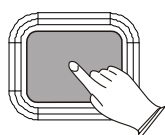

2. Memorizing the Settings to the Preset [M1]-[M6] While Holding Down the [STORE/BANK], Press [M1]-[M6] Button

STORE/BANK

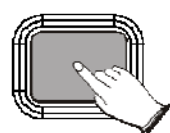

M1



M2

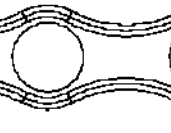

M3

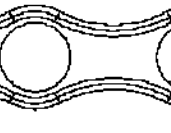

M4

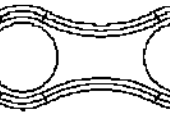

M5

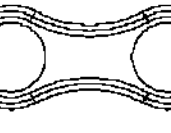

M6

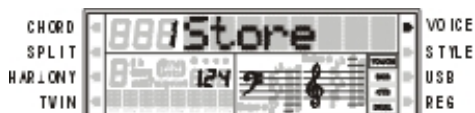

NOTE

Anytime you store to a REGISTRATION MEMORY button, all settings previously stored in that button will be erased and replaced by the new settings.

Recalling the Settings

1. Select the Appropriate Registration Memory Bank

Press the [STORE/BANK] button repeatedly to select the bank [1MmryBank]-[4MmryBank].

STORE/BANK

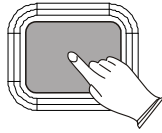

2. Press the Desired Registration Memory Preset [M1]-[M6] Button

The settings stored to a REGISTRATION MEMORY button can be recalled simply by pressing the appropriate button [M1]-[M6].

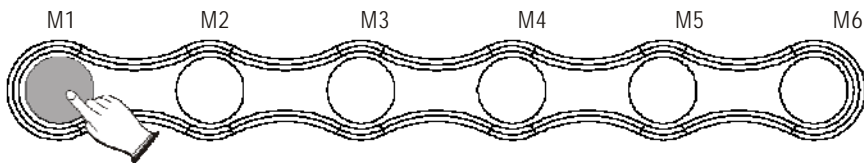

Saving the Registration Data to USB Disk

Insert the USB Disk into the USB terminal.
The USB cursor will appear on the LCD-Display.

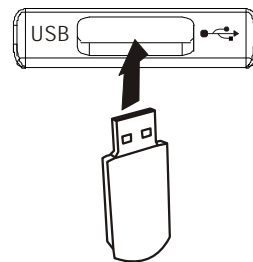

Press [SAVE] button, a message “xREGSTxxx” (x indicates this file's sequence Num in UDisk. xxx indicates registration file number) appears, indicating your Registration Memory Settings are saved to USB Disk, with 24 Registrations stored to a single file.

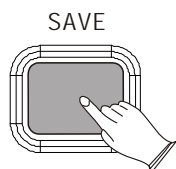

Use Registration Data from USB

Insert the USB Disk into the USB terminal. Use [+] and [-] buttons to select REG file, then press [PLAY/LOAD] button, display shows “Load OK” .

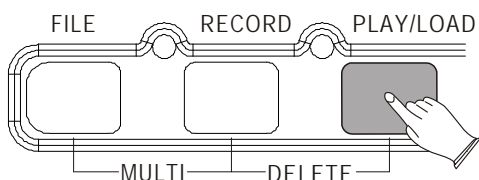

24 Registrations will be loaded to the memory store(4*6) on the panel. You can recall the information you have loaded by pressing M1-M6.

Delete REG File from USB

Insert the USB Disk into the USB terminal. Use [+] and [-] buttons to select “REG” file you want to delete, then hold down the [RECORD] button and press [PLAY/LOAD] button. LCD shows:

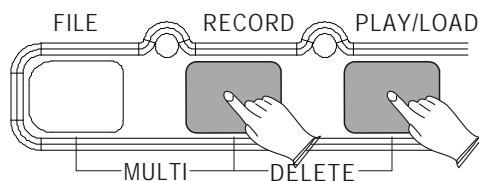

Press [+] button to delete the file.
Press [-] button to cancel.

Song Recording

This digital piano lets you record your performances and Registration settings to a USB Disk. Each user song lets you record up to sixteen independent tracks. These include not only the voices for the keyboard performance, but also the auto accompaniment parts.

It provides two different ways to record: Quick Recording and Multi Track Recording.

(All the recording data will be saved automatically as MIDI Format 0 File to your USB Disk).

Quick Recording

1. Insert the USB Disk into the USB Terminal

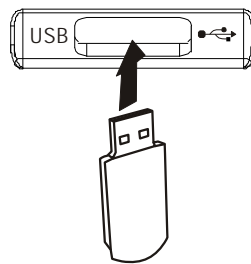

2. Start Recording

Press the [RECORD] button to start recording.

(The first two measures are tempo prompt only. It cannot record any data).

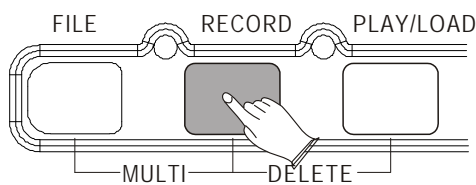

3. Stop Recording

Press [RECORD] button again to stop recording.

Recording stops and your performance is written to the song. The song to which your performance is recorded is automatically named “xMUSIC xxx” (x indicates this file's sequence Num in UDisk. xxx indicates the recording file number). You can edit the song as desired by computer or midi edit soft.



Quick Recording automatically makes track assignments as below:

Track 1----- Main Voice
Track 2----- Split Voice
Track 3----- Dual Voice

You also can use accompaniment styles to record. The accompaniment style will be recorded on track9-track16.

The quick recording method is different from the multi recording method. In quick recording mode, track4-track8 are not allowed to record. but for multi recording, the recorded data is recorded on tracks 1-16.

If you wish to re-record a user song that was originally recorded by the easy recording method, please use Multi Track Recording.

Multi Track Recording

Multi track recording provides two ways to record:

1. Use Auto Track Assignment.
2. Select Tracks by yourself.

1. Use Auto Track Assignment

1.1 Insert the USB Disk Into the USB Terminal

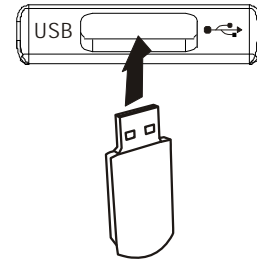

1.2 Turn the Auto Track On

Reference: F7 Auto Track(P.20).

1.3 Start Recording

Press the [RECORD] button to start recording.

(The first two measures are tempo prompt only. It cannot record any data).

When the recording is finished, the recording file will be saved with the name "1 MUSIC000" .

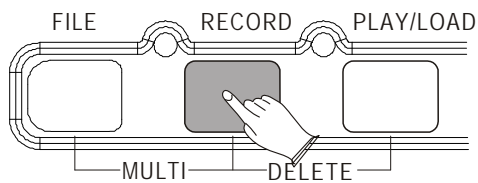

1.4 To Stop Recording by Pressing [RECORD] Button Again.

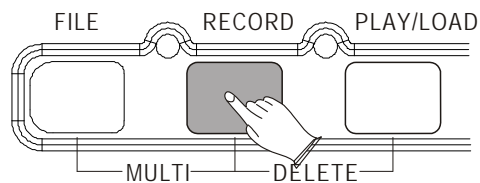

1.5 Hold Down the [FILE] Button, Then Press [RECORD] Button

The next track will be given automatically. The performance will be recorded to the next track on the basis of “1 MUSIC000” .

When the recording is finished, the recording file will be saved as a new file named “2 MUSIC001” .

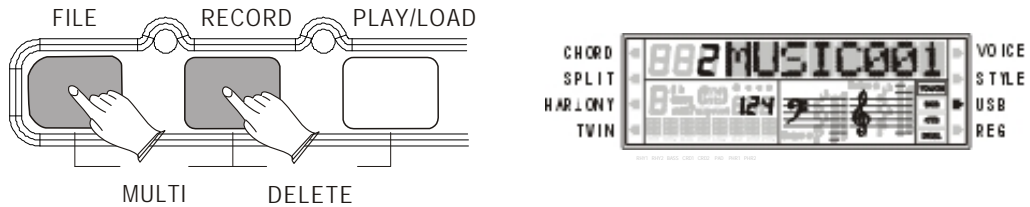

1.6 Use the Same Operation as Step 5 to Record More Tracks. The Name of the New File Will be Saved in Sequence.

1.7 To Stop Recording by Pressing [RECORD] Button Again.

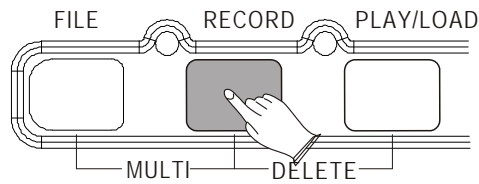

2. Select Tracks by Yourself

2.1 Insert the USB Disk Into the USB Terminal

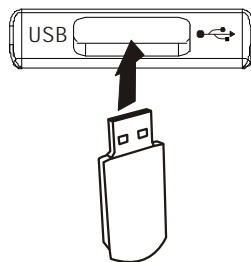

2.2 Turn the Auto Track Off

Reference: F7 Auto Track(P.20).

2.3 Select Recording Track

Press [TRACK] button repeatedly can select three voice mode, you can use [+] and [-] buttons to select the track(01-16) in each mode.

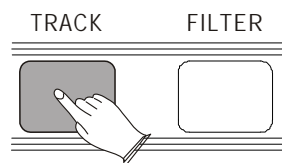

- R. RecTrk-----to select the Main Voice track(01-16, OFF)
- L. RecTrk-----to select the Split Voice track(01-16, OFF)
- D. RecTrk-----to select the Dual Voice track(01-16, OFF)

2.4 Start Recording

Press [RECORD] button to start recording.

(The first two measures are tempo prompt only. It cannot record any data).

When the recording is finished, the recording file will be saved with the name "1 MUSIC000" .

To Stop Recording by Pressing [RECORD] Button Again.

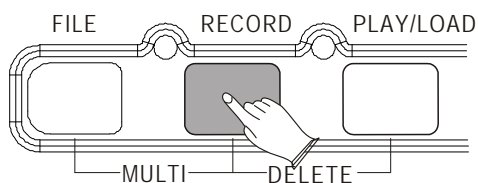

(Please turn the "L.RecTrk" or "D.RecTrk" off without Split or Dual voice recording.)

2.5 Repeat Step 3 to Select Next Track

2.6 Hold Down the [FILE] Button, Then Press [RECORD] Button

The performance will be recorded to the desired track on the basis of “1 MUSIC000” .

When the recording is finished, the recording file will be saved as a new file named “2 MUSIC001” .

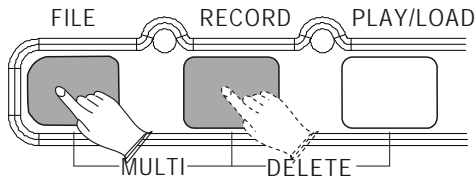

2.7 Use the Same Operation as Step 3 and Step 6 to Record More Tracks.

The Name of the New File Will be Saved in Sequence.

2.8 To Stop Recording by Pressing [RECORD] Button Again.

Delete Song

Insert the USB Disk into the USB terminal. Use [+] and [-] buttons to select “xMUSICxxx” file you want to delete, then hold down the [RECORD] button and press [PLAY/LOAD] button. LCD shows:

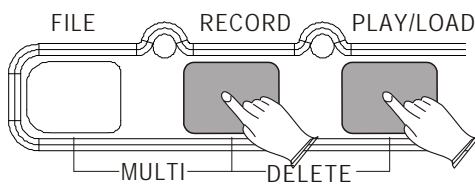

Press [+] button to delete the file.

Press [-] button to cancel.

File Button

Use this button you can switch to USB mode immediately even the keyboard is in any of other mode.

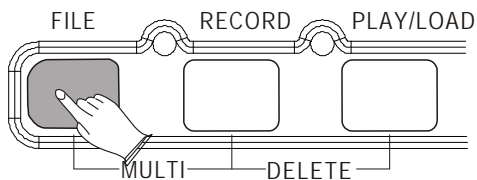

Filter Button

Use this function you can turn on or turn off any tracks and change the metronome's tempo before song playing or recording.

Press [FILTER] button repeatedly to select the track.

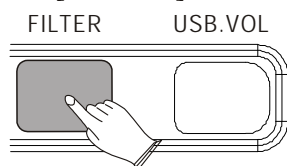

Use [+] and [-] buttons to select "ON" or "OFF".

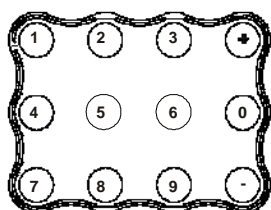

For example: a midi file is prepare for playing, but track 1 or track 2, you would not like to play it with other tracks, so you can press [FILTER] button to select "FLtTrk01" or "FLtTrk02", use [+] or [-] button to turn off it. Track 1 or track 2 will be closed.

Press [FILTER] button repeatedly to select "FltTmp". Use [+] and [-] buttons to select "ON" or "OFF".

ON: Whenever you play any songs, the tempo will be not change.

OFF: The tempo will be changed by the different songs.

NOTE

The [FILTER] button is disabled while playing or recording.

Adjusting Song's Volume

Press [USB.VOL] button while playing song.

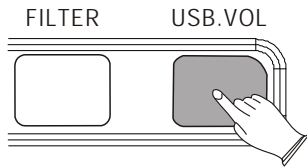

Use [+] and [-] buttons or number (0-9) buttons to adjust the song's volume.
Range: 00-127 Default: 100

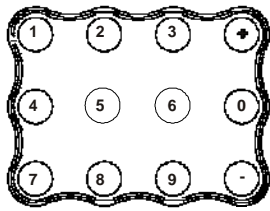

Factory Set

1. Turn off the power.



2. Hold down [+] and [-] buttons, then turn the power on, it can restore all internal settings to factory set.

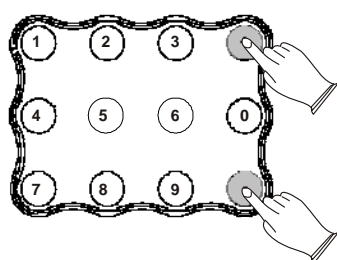

Appendix

Voice List

No.	No.	TO NE	Q/PAN/ auto
Piano			
01	00	Acoustic Grand Piano	1
02	01	Bright Acoustic Piano	1
03	02	Electric Grand Piano	2
04	03	Honky-Tonk Piano	2
05	04	Electric Piano 1	2
06	05	Electric Piano 2	2
07	06	Harpicoid	1
08	07	Clav	1
Chromatic Percussion			
09	08	Celesta	1
10	09	Glockenspiel	1
11	10	Musical Box	2
12	11	Vibraphone	1
13	12	Marimba	1
14	13	Xylophone	1
15	14	Tubular Bells	1
16	15	Dulcimer	2
Organ			
17	16	Drawbar Organ	2
18	17	Permissive Organ	2
19	18	Rock Organ	2
20	19	Church Organ	2
21	20	Reed Organ	1
22	21	Accordion	2
23	22	Hammond	1
24	23	Tango Accordion	2
Guitar			
25	24	Acoustic Guitar (Nylon)	1
26	25	Acoustic Guitar (Steel)	1
27	26	Electric Guitar (Jazz)	1
28	27	Electric Guitar (Clean)	2
29	28	Electric Guitar (Muted)	1
30	29	Overdriven Guitar	1
31	30	Distortion Guitar	1
32	31	Guitar Harmonics	1
Bass			
33	32	Acoustic Bass	1
34	33	Finger Bass	1
35	34	Pick Bass	1
36	35	Fretless Bass	1
37	36	Slap Bass 1	1
38	37	Slap Bass 2	1
39	38	Synth Bass 1	1
40	39	Synth Bass 2	1
Strings			
41	40	Violin	1
42	41	Viola	1
43	42	Cello	1
44	43	Contrabass	1
45	44	Tremolo Strings	2
46	45	Pizzicato Strings	2
47	46	Orchestral Harp	2
48	47	Timpani	1
Ensemble			
49	48	Strings Ensemble 1	1

No.	No.	TO NE	Q/PAN/ auto
50	49	Strings Ensemble 2	1
51	50	Synth Strings 1	2
52	51	Synth Strings 2	2
53	52	Choir Aahs	2
54	53	Voice Oohs	1
55	54	Synth Voice	1
56	55	Orchestra Hit	1
Brass			
57	56	Trumpet	1
58	57	Trombone	1
59	58	Tuba	1
60	59	Muted Trumpet	1
61	60	French Horn	1
62	61	Brass Section	1
63	62	Synth Brass 1	2
64	63	Synth Brass 2	2
Reed			
65	64	Soprano Sax	1
66	65	Alto Sax	1
67	66	Tenor Sax	1
68	67	Baritone Sax	1
69	68	Oboe	1
70	69	English Horn	1
71	70	Bassoon	1
72	71	Clarinet	1
Pipe			
73	72	Piccolo	1
74	73	Flute	1
75	74	Recorder	1
76	75	Pan Flute	1
77	76	Blown Bottle	2
78	77	Shakuhachi	1
79	78	Whistle	1
80	79	Ocarina	1
Synth Lead			
81	80	Lead 1 (Square)	2
82	81	Lead 2 (Sawtooth)	2
83	82	Lead 3 (Calliope)	2
84	83	Lead 4 (Chiff)	2
85	84	Lead 5 (Charang)	2
86	85	Lead 6 (Voice)	2
87	86	Lead 7 (Fifth)	2
88	87	Lead 8 (Bass+Lead)	2
Synth Pad			
89	88	Pad 1 (New Age)	2
90	89	Pad 2 (Warm)	2
91	90	Pad 3 (Polysynth)	2
92	91	Pad 4 (Choir)	2
93	92	Pad 5 (Bowed)	2
94	93	Pad 6 (Metallic)	2
95	94	Pad 7 (Halo)	2
96	95	Pad 8 (Sweep)	2
Synth Effects			
97	96	Fx 1 (Rain)	2
98	97	Fx 2 (Soundtrack)	2
99	98	Fx 3 (Crystal)	2

No.	No.	TO NE	Q/PAN/ auto
100	99	Fx 4 (Atmosphere)	2
101	100	Fx 5 (Brightness)	2
102	101	Fx 6 (Goblins)	2
103	102	Fx 7 (Echoes)	2
104	103	Fx 8 (Sci-Fi)	2
Ethnic			
105	104	Sitar	1
106	105	Banjo	1
107	106	Shamisen	1
108	107	Koto	1
109	108	Kalimba	1
110	109	Bagpipe	2
111	110	Fiddle	1
112	111	Shanai	1
Percussive			
113	112	Tinkle Bell	2
114	113	Agogo	1
115	114	Steel Drums	2
116	115	Woodblock	1
117	116	Talko Drum	1
118	117	Melodic Tom	1
119	118	Synth Drum	1
120	119	Reverse Cymbal	1
Sound Effects			
121	120	Guitar Fret Noise	1
122	121	Breath Noise	1
123	122	Seashore	2
124	123	Bird Tweet	2
125	124	Telephone Ring	1
126	125	Helicopter	2
127	126	Applause	2
128	127	Gunshot	1
129		Standard P.	
130		Room P.	
131		Power P.	
132		Elect. P.	
133		Synth P.	
134		Dance P.	
135		Jazz P.	
136		Brush P.	
137		Classic P.	
138		Drum P.	
139		Effect	

Style List

NO	STYLE NAME	NO	STYLE NAME	NO	STYLE NAME
8 BEAT		35	LATIN DISCO	70	MAMBO
01	8BEAT MODERN	36	DISCO	71	SALSA
02	MERSEY BEAT	37	DISCO PARTY	72	BEGUINE
03	SURF POP	38	DISCO FEVER	73	REGGAE
04	8BEAT	39	NEWYORK DISCO	74	SWINGY REGGAE
05	60'S ROCK	SWING&JAZZ		BALLROOM	
06	HARD ROCK	40	BIG BAND FAST	75	DANCE BAND
07	ROCK SHUFFLE	41	BIG BAND MID	76	ENGLISH WALTZ
08	80'S ROCK	42	BIG BAND BALLD	77	FOXTROT
16 BEAT		43	JAZZ CLUB	78	QUICK FOXTROT
09	16 BEAT1	44	SWING	79	QUICKSTEP
10	16 BEAT2	45	JAZZ BALLAD	80	TANGO
11	POP SHUFFLE	46	DIXIE LAND	81	HABENERA TANGO
12	GUITAR POP	47	RAGTIME	82	PASODOBLE
13	JAZZ ROCK	48	STRIDE PIANO	83	SAMBA
14	SWING FUNK	49	MODERN JAZZ	84	CHACHA
15	POP ROCK	R&B		85	JIVE
BALLAD		50	SOUL	86	RHUMBA
16	PIANO BALLAD	51	DETROIT POP	87	VIENNESE WALTZ
17	LOVE SONG	52	RHYTHM&BLUES	TRADITIONAL	
18	6/8 MODERN	53	6/8 SOUL	88	2/4 MARCH
19	6/8 SLOW ROCK	54	TWIST	89	6/8 MARCH
20	SHOW BALLAD	55	ROCK&ROLL	90	2/4 POLKA
21	POP BALLAD	56	BOOGIEWOOGIE	91	6/8 POLKA
22	16BEAT BALLAD	57	6/8 BLUES	92	TARANTELLA
DANCE		58	3/4 GOSPEL	93	SIRTAKI
23	RAP	59	GOSPEL SHUFFLE	94	SCOTTISH REEL
24	DANCE POP	COUNTRY		95	HAWAIIAN
25	HOUSE	60	COUNTRY 8 BEAT	96	MARIACHI
26	SWING HOUSE	61	COUNTRY POP	WALTZ	
27	CLUB DANCE	62	COUNTRY SWING	97	SWING WALTZ
28	CLUB LATIN	63	COUNTRY 2 STEP	98	JAZZ WALTZ
29	GARAGE	64	COUNTRY BALLAD	99	WALTZ
30	TECHNO	65	BLUE GRASS	100	FRENCH WALTZ
31	DANCE 8BEAT	66	COUNTRY WALTZ	101	USER STYLE
32	HIP HOP	LATIN			
33	CHILL OUT	67	MERENGUE		
DISCO		68	BOSSANOVA		
34	70'S DISCO	69	POP BOSSA		

Percussion Voice List

Note#	Note	Standard(0)	Room(8)	Power(16)	Electronic(24)	Synth(25)	Dance(26)	Jazz(32)	Brush(40)	Classic(48)	Drum(56)	Effects(56)
24	C	Seq Click H	←	←	←	←	←	←	←	←	←	←
25	#C	Brush Tap	←	←	←	←	←	←	←	←	←	←
26	D	Brush Swirl L	←	←	←	←	←	←	←	←	←	←
27	#D	Brush Slap	←	←	←	←	←	←	←	←	←	←
28	E	Brush Swirl H	←	←	Rever se Cymbal	Rever se Cymbal	←	←	←	←	←	←
29	F	Snare Roll	←	←	←	←	←	←	←	←	←	←
30	#F	Castanet	←	←	Hi-Q	Hi-Q	←	←	←	←	←	←
31	G	Snare L	←	SD Elec M	Snare L	SD Elec H2	←	Snare Jazz	Brush Slap L	←	Snaer H Soft 2	←
32	#G	Sticks	←	←	←	←	←	←	←	←	←	←
33	A	Bass Drum L	←	←	←	←	←	←	←	Bass Drum L3	←	←
34	#A	Open Rim Shot	←	←	←	←	Dance 1	←	←	←	Open Rim Shot 2	←
35	B	Bass Drum M	←	←	BD Rock	BD Analog 1L	Dance Kick	←	←	Gran Casa	←	←
36	C	Bass Drum H	←	BD Rock	BD Rock 2	BD Analog 1H	Dance 2	BD Jazz	BD Jazz	Gran Casa Mute	Bass Drum H 2	←
37	#C	Side Stick	←	←	Analog Side Stick	←	Dance 3	←	←	←	←	←
38	D	Snare M	SD Room L	SD Rock	SD Elec M	SD Analog 1H	Dance Snare 1	SD Jazz L	Brush Slap H	Marching SD M	Snare L2	←
39	#D	Hand Clap	←	←	←	←	Dance 4	←	←	←	←	High-Q
40	E	Snare H	SD Room H	SD Rock Rim	SD Elec H	SD Analog 1L	Dance Snare 2	SD Jazz H	Brush Tap	Marching SD H	Snare H Hard 2	Slap
41	F	Floor Tom L	Room Tom 1	Rock Tom 1	E Tom 1	Analog Tom 1	Dance Tom 1	←	Brush Tom 1	←	←	Scratch Push
42	#F	Hi-Hat Closed	←	←	←	Analog HH Closed	Dance Hita 1	←	←	←	←	Scratch Pull
43	G	Floor Tom H	Room Tom 2	Rock Tom 2	E Tom 2	Analog Tom 2	Dance Tom 2	←	Brush Tom 2	←	←	Sticks
44	#G	Hi-Hat Pedal	←	←	←	Analog HH Closed	Dance Hita 2	←	←	←	←	Square Click
45	A	Low Tom	Room Tom 3	Rock Tom 3	E Tom 3	Analog Tom 3	Dance Tom 3	←	Brush Tom 3	←	←	Mtrnm Click
46	#A	Hi-Hat Open	←	←	←	Analog HH 1Open	Dance Hita 3	←	←	←	←	Mtrnm Bell
47	B	Mid Tom L	Room Tom 4	Rock Tom 4	E Tom 4	Analog Tom 4	Dance Tom 4	←	Brush Tom 4	←	←	Gt FretNoiz
48	C	Mid Tom H	Room Tom 5	Rock Tom 5	E Tom 5	Analog Tom 5	←	←	Brush Tom 5	←	←	Gt CutNoise
49	#C	Crash Cymbal	←	←	←	Analog Cymbal	Dance Cha 1	←	←	Hand Cym L Open	←	Gt CutNoise
50	D	High Tom	Room Tom 6	Rock Tom 6	E Tom 6	Analog Tom 6	←	←	Brush Tom 6	←	←	String Slap
51	#D	Ride Cymbal 1	←	←	←	←	←	←	←	Hand Cym L Closed	←	Fl Key Click
52	E	Chinese Cymb	←	←	←	←	←	←	←	←	←	Laughing
53	F	Ride Cymbal 2	←	←	←	←	←	←	←	←	←	Screaming
54	#F	Tambourine	←	←	←	←	Dance Ling	←	←	←	←	Punch
55	G	Splash Cymbal	←	←	←	←	←	←	←	←	←	Heart Beat
56	#G	CowBell	←	←	←	Analog Cowbell	←	←	←	←	←	Footsteps 1
57	A	Crash Cymbal	←	←	←	←	Dance Cha 2	←	←	Hand Cym H Open	←	Footsteps 2
58	#A	Vibraslap	←	←	←	←	←	←	←	←	←	Applause
59	B	Ride Cymbal 2	←	←	←	←	←	←	←	Hand Cym H Closed	←	Door Creaking
60	C	Bongo H	←	←	←	←	←	←	←	←	←	Door
61	#C	Bongo L	←	←	←	←	←	←	←	←	←	Scratch
62	D	Conga H Mute	←	←	←	Analog Conga H	←	←	←	←	←	Wind Chimes
63	#D	Conga H Oper	←	←	←	Analog Conga M	←	←	←	←	←	Car-Engine
64	E	Conga L	←	←	←	Analog Conga L	←	←	←	←	←	Car-Stop
65	F	Timbale H	←	←	←	←	←	←	←	←	←	Car-Pass
66	#F	Timbale L	←	←	←	←	←	←	←	←	←	Car-Crash
67	G	Agogo H	←	←	←	←	←	←	←	←	←	Siren
68	#G	Agogo L	←	←	←	←	←	←	←	←	←	Train
69	A	Cabasa	←	←	←	←	←	←	←	←	←	Jetplane
70	#A	Maracas	←	←	←	Analog Maracas	Dance 5	←	←	←	←	Helicopter
71	B	Samba Whistle	←	←	←	←	Dance 6	←	←	←	←	Starship
72	C	Samba Whistle	←	←	←	←	Dance 7	←	←	←	←	Gun Shot
73	#C	Cuiro Short	←	←	←	←	Dance 8	←	←	←	←	Machine Gun
74	D	Cuiro Long	←	←	←	←	Dance 9	←	←	←	←	LaserGun
75	#D	Claves	←	←	←	Analog Claves	Dance 10	←	←	←	←	Explosion
76	E	Wood Block H	←	←	←	←	←	←	←	←	←	Dog
77	F	Wood Block L	←	←	←	←	Dance 11	←	←	←	←	HorseGallop
78	#F	Guica Mute	←	←	Scratch Push	Scratch Push	Dance 12	←	←	←	←	Bird
79	G	Guica Open	←	←	Scratch Pull	Scratch Pull	←	←	←	←	←	Rain
80	#G	Triangle Mute	←	←	←	←	←	←	←	←	←	Thunder
81	A	Triangle Open	←	←	←	←	Dance 13	←	←	←	←	Wind
82	#A	Shaker	←	←	←	←	Dance 14	←	←	←	←	Seashore
83	B	Jingle Bell	←	←	←	←	←	←	←	←	←	Stream
84	C	Bell Tree	←	←	←	←	Dance Ps3	←	←	←	←	BuBBle

MIDI Implementation Chart

Function	Transmitted	Recognized	Remarks
Basic Default	(*1)	1-16CH	
Channel Changed	(*1)	1-16CH	
Mode Default	Mode 3	Mode 3	
Messages Altered	X	X	
Note Number : True voice	0-127 *****	0-127 0-127	
Velocity Note ON	O 9nH,v=1-127	O 9nH,v=1-127	
Note OFF	O 9nH,v=0 or 8nh	O 9nH,v=0 or 8nh	
After Key's	X	X	
Pitch Bender	X	O	
Control Change	O	O	Bank Select
0,32	O	O	Modulation
1	X	O	Portamento time
5	X	O	Data Entry
6	O	O	Volume
7	O	O	Pan
10	O	O	Expression
11	X	O	Sustain
64	O	O	Portamento
65	X	O	Sostenuto
66	O	O	Soft pedal
67	O	O	DSP TYPE
80,81	O	O	DSP DEPTH
91,93	O	O	RPN LSB,MSB
100,101	O	O(*2)	All sound off
120	O	O	Reset all Controllers
121	X	O	Local control
122	O	O	
Program Change : True	O 0-127 0-127	O 0-127 0-127	
System Exclusive	X	O	
System : Song Position	X	X	
: Song Select	X	X	
Common : Tune	X	X	
Aux : Local on/off	O	O	
: All Notes Off	O	O	
Messages : Active Sense	X	O	
: Reset	X	O	

Mode1:OMNI ON,POLY Mode2:OMNI ON,MONO O: Yes
 Mode3:OMNI OFF,POLY Mode4:OMNI OFF,MONO X: NO

- *1: Main voice track (01-16).Default: 01
 Split voice track (01-16).Default: 02
 Dual voice track (01-16).Default: 03
 Percussion track (01-16).Default: 10
- *2: Registered parameter number:
 #0: Pitch sensivity
 #1: Fine tuning cents
 #2: Coarse tuning in half-tones

Specifications

Keyboard:

88 Keys With Touch Sensitivity

Display:

LCD Display

Voice:

139

Polyphony:

64

Voice Control:

Dual, Touch, Trans, Split, Twin

Pedals:

Sof

Effect:

Reverb, Chorus

Auto Accompaniment:

100 Styles, 1 User Style

Demo Song:

3

Registration Memory:

4*6 Panel Setting,

Memorize to USB

USB Host

Song Recording:

Quick Recording,

Multi Recording,

Recording Tracks: 1-16

Midi:

Transmit Settings

Receive Settings

Local Control

USB MIDI

Connectors:

MIDI In/Out, Pedal, Line In/Out,

Phones, USB Socket

Speakers:

YDG50: 4Ω*2W*2

YD134: 4Ω*20W*2

Dimensions(W x D x H)

A:1525mm*655mm*445mm

B:1450mm*360mm*230mm

Weight:

A:58Kgs

B:18Kgs

Supplied Accessories:

Owner's Manual

Assembly Instructions

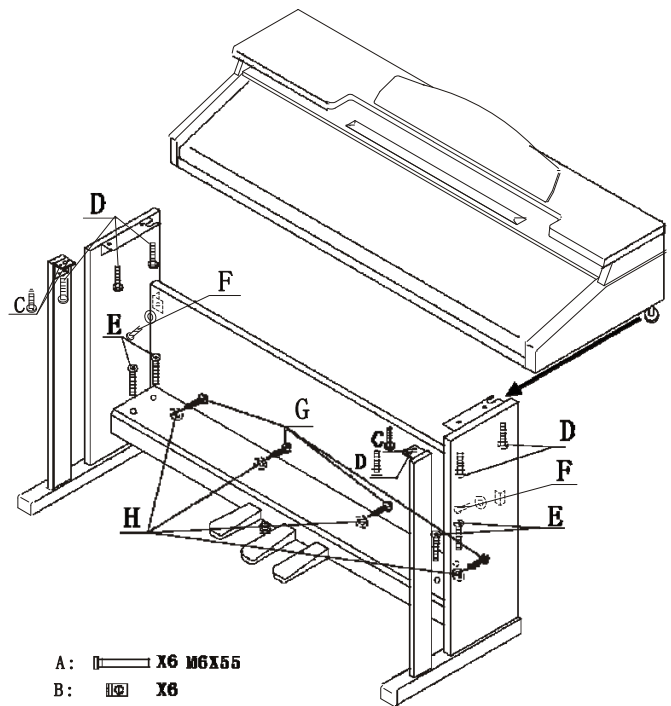
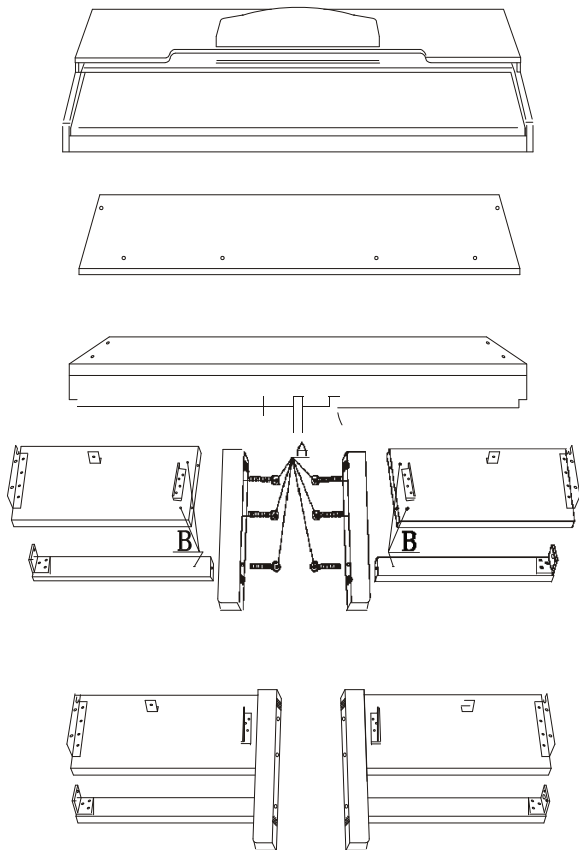

- A: X6 M6X55
- B: X6
- C: X4
- D:
- E:
- F:
- G:
- H: d=4

Turn the adjustable Pedal Board support, until it is in firm contact with the floor.

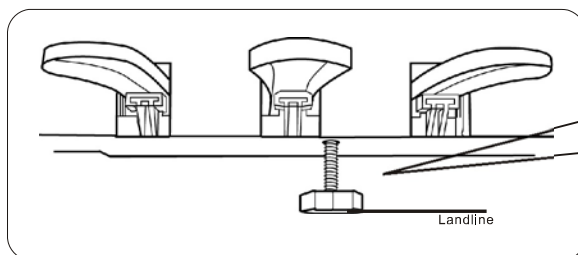

Before moving the piano to a new location, always remember to raise the level of the Pedal Board support so that it is not touching the floor. Once the piano is in place, you can adjust it so it is in firm contact with the floor again.

10505413V4.0

