

**EN** Open and pull out the tamper covers on the top and bottom of both the Tx and Rx rails.

**IT** Aprire ed estrarre i coperchi dei tamper superiore e inferiore di entrambe le barriere Tx ed Rx.

**ES** Aflojar los tornillos y extraer las cubiertas del tamper situadas en la parte superior e inferior de las barreras Tx y Rx.

**FR** Ouvrir et retirer les couvercles d'AP situés en haut et en bas des rails Tx et Rx.

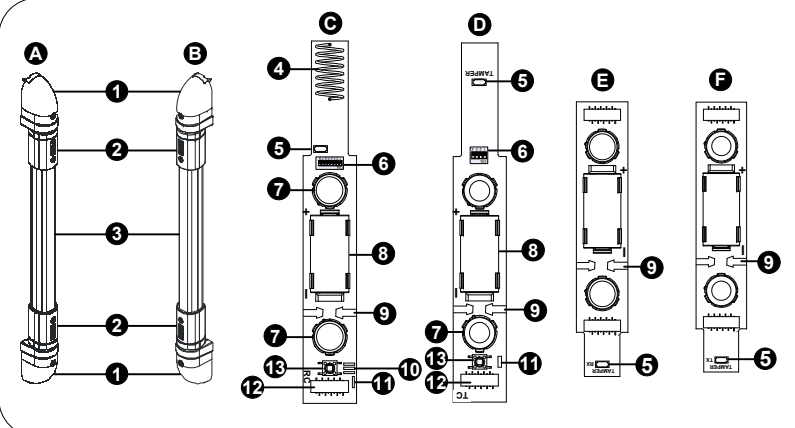

**EN** Select a mounting location. Make sure the TX / RX sticker is on the top of each rail.

**IT** Scegliere un luogo per l'installazione. Assicurarsi che l'adesivo TX / RX sia posto nella parte superiore di ogni barriera.

**ES** Seleccionar una ubicación de montaje. Asegurarse que la pegatina TX / RX está en la parte superior de ambas barreras.

**FR** Choisir le lieu de montage. S'assurer que l'étiquette TX / RX est en haut de chaque rail.

- EN**
- A Tx Rail
  - B Rx Rail
  - C RC (Rx Master)
  - D TC (Tx Master)
  - E RX (Slave)
  - F TX (Slave)
  - 1 Wall Tamper Cover
  - 2 Swivel Cover
  - 3 IR Filter Covering
  - 4 Antenna in Receiver Beam
  - 5 Wall Tamper Connector
  - 6 Dipswitches
  - 7 IR Lens
  - 8 Battery Compartment
  - 9 PCB Spring Locker
  - 10 3 LED Bar
  - 11 Alarm LED
  - 12 Flat Cable Connector
  - 13 Tamper Switch

- IT**
- A Barriera Tx
  - B Barriera Rx
  - C RC (Rx Master)
  - D TC (Tx Master)
  - E RX (Slave)
  - F TX (Slave)
  - 1 Copertura Tamper Antirimozione
  - 2 Copertura Snodo
  - 3 Copertura IR
  - 4 Antenna della Barriera Rx
  - 5 Connettore per il Tamper Antirimozione
  - 6 Microinterruttori
  - 7 Lenti IR
  - 8 Alloggiamento Batteria
  - 9 Clip di fissaggio dell'elettronica
  - 10 Barra a 3 Led
  - 11 Led Allarme
  - 12 Connettore Piatto
  - 13 Interruttore Tamper

- ES**
- A Barrera Tx (Emisor)
  - B Barrera Rx (Receptor)
  - C RC (Rx Maestro)
  - D TC (Tx Maestro)
  - E RX (Esclavo)
  - F TX (Esclavo)
  - 1 Cubierta Tamper Pared
  - 2 Cubierta Rótula
  - 3 Cubierta Filtro IR
  - 4 Antena Receptor
  - 5 Conector Tamper Pared
  - 6 Interruptores DIP
  - 7 Lente IR
  - 8 Compartimento Bateria
  - 9 Resorte Sujeción PCB
  - 10 Barra de 3 LEDs
  - 11 LED de Alarma
  - 12 Conector Cable Plano
  - 13 Interruptor Tamper

- FR**
- A Rail Tx
  - B Rail Rx
  - C RC (Rx Maître)
  - D TC (Tx Maître)
  - E RX (Esclave)
  - F TX (Esclave)
  - 1 Couvercle d'AP à l'arrachement
  - 2 Couvercle du pivot
  - 3 Couvercle Filtre IR
  - 4 Antenne du Récepteur
  - 5 Connecteur de l'AP à l'arrachement
  - 6 Dipswitchs
  - 7 Lentilles IR
  - 8 Compartiment Batterie
  - 9 Ressort de fixation du PCB
  - 10 Barre 3 LED
  - 11 LED d'alarme
  - 12 Câble de connexion plat
  - 13 Contact d'AP

**EN** Remove the swivel covers on the top and bottom of both the Tx and Rx rails.

**IT** Rimuovere le coperture degli snodi superiori ed inferiori di entrambe le barriere.

**ES** Retirar las cubiertas de la rótula de la parte superior e inferior de las barreras Tx y Rx.

**FR** Enlever les couvercles des pivots du haut des rails Tx et Rx.

**EN** Lift and remove the IR filter covering.

**IT** Alzare e rimuovere la copertura IR.

**ES** Levantar y retirar la cubierta del filtro IR.

**FR** Soulever et enlever les couvercles des filtres IR.

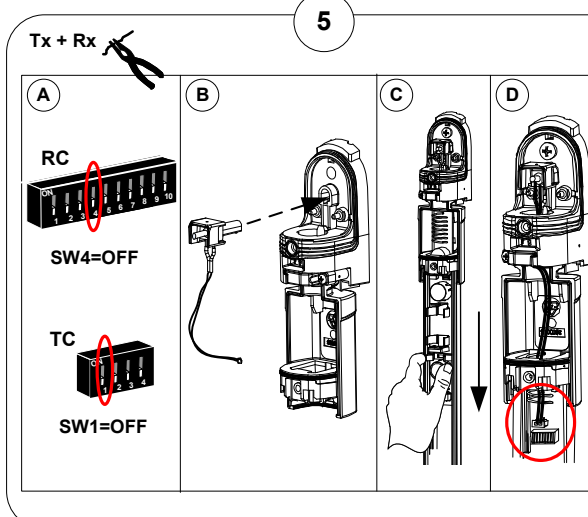

**EN** For Wall Tamper Connection (optional):  
**A.** On the RC (Rx Master unit) set Dipswitch 4 to OFF. On the TC (Tx Master unit) set Dipswitch 1 to OFF.  
**B.** Insert the 4 wall tamper on the top and bottom of each of the Rx and Tx rails.  
**C.** Press the PCB Spring Lockers and slide out the Master and last Slave units of both the Tx and Rx rails.  
**D.** Connect the wall tamper cables to the Wall Tamper Connector.

**IT** Per la connessione del Tamper antirimozione (opzionale):  
**A.** Sull'RC (Rx Master) impostare il Microinterruttore 4 in OFF. Sul TC (Tx Master) impostare il Microinterruttore 1 in OFF.  
**B.** Inserire i 4 Tamper antirimozione negli alloggiamenti di entrambe le barriere.  
**C.** Premere le Clip di fissaggio dell'elettronica e sfilare il Master e l'ultimo Slave di ogni barriera.  
**D.** Innestare i cavi dei Tamper antirimozione ai loro connettori.

**ES** Conexión del Tamper de Pared (opcional):  
**A.** En el RC (Unidad Rx Maestro) colocar el DIP 4 en OFF. En el TC (Unidad Tx Maestro) colocar el DIP 1 en OFF.  
**B.** Colocar los 4 tamper de pared en la parte superior e inferior de las barreras Tx y Rx.  
**C.** Presionar los resortes de sujeción de la PCB y deslizar hacia afuera las unidades Maestro y Esclavo de las barreras Tx y Rx.  
**D.** Conectar los cables de los tamper al Conector del Tamper de Pared.

**FR** Pour la connexion de l'AP à l'arrachement (option) :  
**A.** Sur le RC (Rx Maître), placer le Dipswitch 4 sur OFF. Sur le TC (Tx Maître), placer le Dipswitch 1 sur OFF.  
**B.** Mettre les 4 AP à l'arrachement en haut et en bas des rails Rx et Tx.  
**C.** Appuyer sur les ressorts de fixation du PCB et retirer les unités esclaves des rails Tx et Rx.  
**D.** Connecter les fils de l'AP à l'arrachement sur le connecteur de l'AP à l'arrachement.

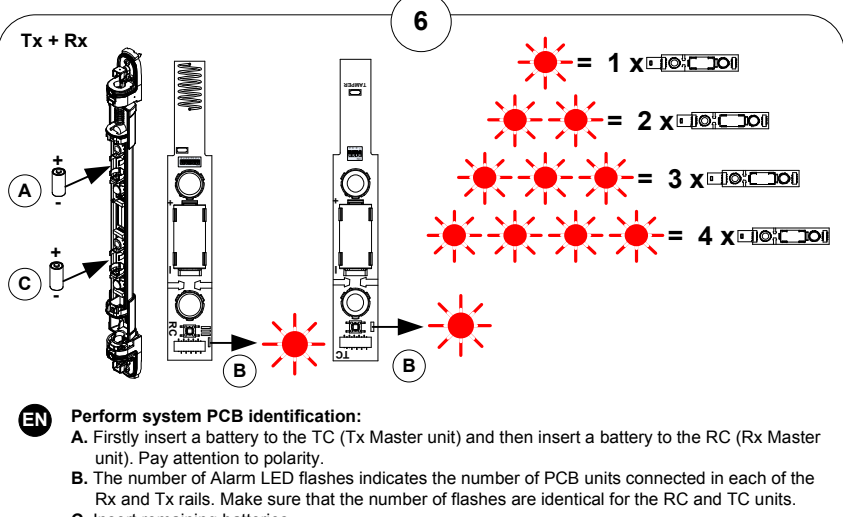

**EN** Perform system PCB identification:  
**A.** Firstly insert a battery to the TC (Tx Master unit) and then insert a battery to the RC (Rx Master unit). Pay attention to polarity.  
**B.** The number of Alarm LED flashes indicates the number of PCB units connected in each of the Rx and Tx rails. Make sure that the number of flashes are identical for the RC and TC units.  
**C.** Insert remaining batteries.

**Notes:** In the case of low battery, the red Alarm LED will flash 4 consecutive times. All batteries should be replaced at the same time.

**IT** Riconoscimento del numero di moduli Slave collegati:  
**A.** Inizialmente inserire una batteria nel TC (unità master Tx) e poi inserirla nell'RC (unità master Rx). Prestare attenzione alla polarità.  
**B.** Il numero di lampeggi del Led Allarme indica quanti moduli Slave sono collegati in ogni barriera. Assicurarsi che il numero di lampeggi corrisponda sia nell'RC che nel TC.  
**C.** Inserire le batterie rimanenti.

**Note:** in caso di batteria scarica il LED rosso di allarme lampeggerà per 4 volte consecutive. Tutte le batterie devono essere sostituite contemporaneamente.

**ES** Identificar las PCB del sistema:  
**A.** Poner primero una pila en el TC (unidad Tx Maestro) y después poner una pila en el RC (unidad Rx Maestro). Prestar atención a la polaridad.  
**B.** El número de parpadeos del LED de alarma indica el número de unidades PCB conectadas en cada barrera Rx y Tx. Asegurarse de que el número de parpadeos es idéntico para las unidades RC y TC.  
**C.** Insertar las pilas restantes.

**Notas:** En caso de batería baja, el LED rojo de Alarma parpadeará 4 veces consecutivas. Deben cambiarse todas las pilas a la vez.

**FR** Faire une identification des PCB du système :  
**A.** Insérer une batterie dans le TC (Tx Maître) et le RC (Rx Maître). Attention à la polarité.  
**B.** Le nombre de clignotements de la LED d'alarme indique le nombre de PCB connecté dans chaque rail Rx et Tx. S'assurer que le nombre de clignotements est identique pour le RC et le TC.  
**C.** Insérer les batteries restantes.

**Notes :** En cas de batterie basse, la LED rouge d'alarme clignotera 4 fois de suite. Toutes les batteries devront être remplacées en même temps.

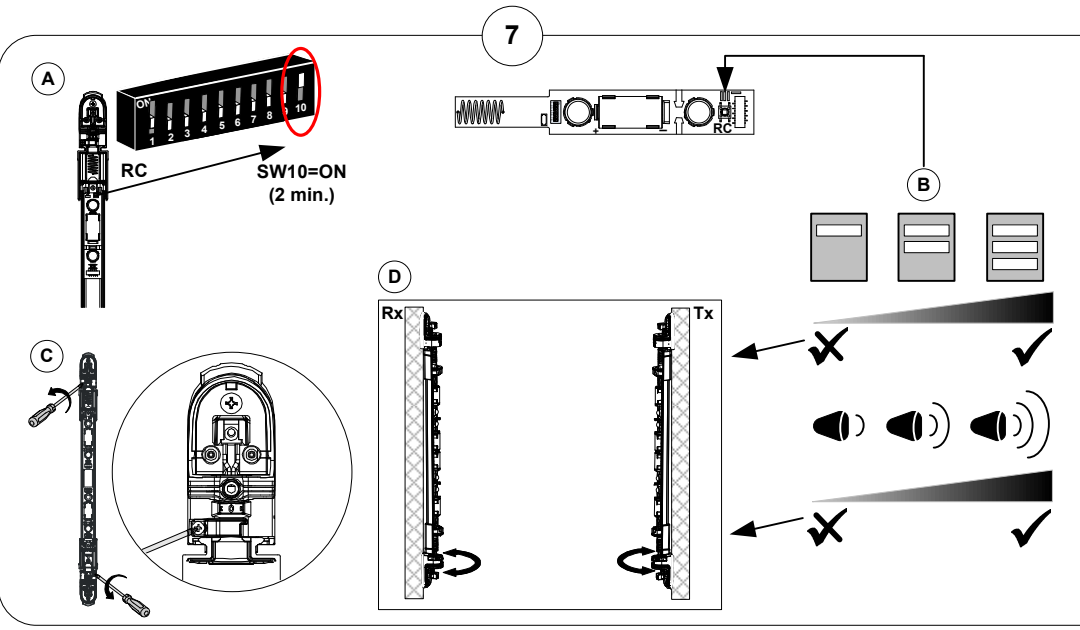

**EN** Perform Rx-Tx beam alignment:  
**A.** Set to Installation mode: On the RC (Rx Master unit) set Dipswitch 10 to ON. Note that the installation mode is active for 2 minutes at a time.  
**B.** Check the 3 LED bar for the maximum signal strength.  
**C.** Release the swivel locking screw on the top and bottom of both the Tx and Rx rails.  
**D.** Swivel the Tx and Rx rails until maximum strength is received.

**To improve signal strength:**

**IT** Effettuare l'allineamento dell'Rx e del Tx:  
**A.** Porsi in modalità Installazione: sull'RC (Rx Master) impostare il Microinterruttore 10 in ON. Ricordarsi che la modalità Installazione è attiva automaticamente dopo 2 minuti dalla modalità Installazione.  
**B.** Guardare la Barra a 3 Led per ottenere il massimo allineamento.  
**C.** Allentare le viti di blocco degli snodi superiori ed inferiori delle barriere.  
**D.** Ruotare il Tx e l'Rx sino a che non si riceve il segnale migliore.

**ES** Alinear los haces Rx-Tx:  
**A.** Entrar en modo Instalación: en el RC (unidad Rx Maestro) poner el DIP 10 en ON. Tenga en cuenta que el modo de instalación estará activo durante 2 minutos.  
**B.** Compruebe la barra de 3 LEDs para obtener la máxima intensidad de señal.  
**C.** Soltar el tornillo de fijación de la rótula de la parte superior e inferior de las barreras Tx y Rx.  
**D.** Girar las barreras Tx y Rx hasta recibir la máxima señal.

**FR** Aligner les faisceaux Rx-Tx :  
**A.** Se mettre en mode installation : Sur le RC (Rx Maître), placer le Dipswitch 10 sur ON. Le mode d'installation s'active alors pour 2 minutes.  
**B.** Contrôler la barre 3 LED pour obtenir une force de signal maximale.  
**C.** Enlever la vis de verrouillage de position en haut et en bas des rails Tx et Rx.  
**D.** Faire pivoter les rails Tx et Rx jusqu'à obtenir un force de signal maximale.

**Pour améliorer la force du signal :**

**EN** Return to Normal mode: On the RC set Dipswitch 10 to OFF.  
**IT** Per tornare in modalità Normale: Sull'RC riportare il Microinterruttore 10 in OFF.  
**ES** Volver al modo Normal: en el RC poner el DIP 10 en OFF.  
**FR** Se mettre en mode normal : Sur le RC, placer le Dipswitch 10 sur OFF.

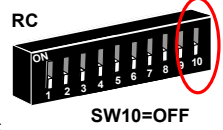

**9**  
**Tx + Rx**



- EN** Lock the swivel screws on both the Tx and Rx rails. Make sure that the alignment remains fixed.
- IT** Tirare le viti degli snodi su entrambe le barriere. Assicurarsi che durante l'operazione non si disallineino.
- ES** Fijar los tornillos de la rótula en las dos barreras Tx y Rx. Asegurarse de que se mantiene la alineación.
- FR** Revisser les vis de verrouillage de position des rails Tx et Rx. S'assurer que l'alignement reste fixe.

**10**  
**Tx + Rx**

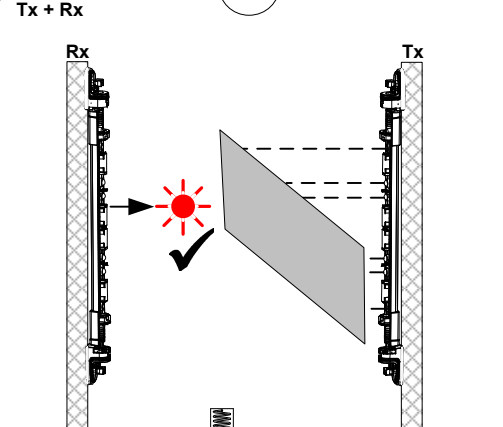

- EN** Perform IR detection test. Alarm LED should light up during detection.
- IT** Test di rilevazione degli IR. Il Led Allarme deve accendersi ad ogni rilevazione.
- ES** Realizar una prueba de detección del IR. El LED de Alarma deberá encenderse durante la detección.
- FR** Faire un test de détection IR. La LED d'alarme devrait s'allumer lors d'une détection.

**13**  
**Tx + Rx**

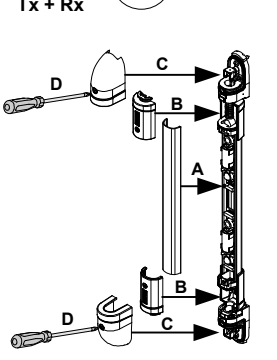

- EN** Close the Tx and Rx rails according to the A, B, C, D order in the diagram above.
- IT** Chiudere il Tx e l'Rx seguendo i passi A, B, C, e D del diagramma.
- ES** Cerrar las barreras Tx y Rx según el orden indicado en el diagrama superior: A, B, C, D.
- FR** Fermer les rails Tx et Rx en suivant l'ordre A, B, C, D du diagramme ci-dessus.

**RISCO Group Limited Warranty**  
 RISCO Group and its subsidiaries and affiliates ("Seller") warrants its products to be free from defects in materials and workmanship under normal use for 24 months from the date of production. Because Seller does not install or connect the product and because the product may be used in conjunction with products not manufactured by the Seller, Seller cannot guarantee the performance of the security system which uses this product. Seller's obligation and liability under this warranty is expressly limited to repairing and replacing, at Seller's option, within a reasonable time after the date of delivery, any product not meeting the specifications. Seller makes no other warranty, expressed or implied, and makes no warranty of merchantability or of fitness for any particular purpose. In no case shall seller be liable for any consequential or incidental damages for breach of this or any other warranty, expressed or implied, or upon any other basis of liability whatsoever. Seller's obligation under this warranty shall not include any transportation charges or costs of installation or any liability for direct, indirect, or consequential damages or delay. Seller does not represent that its product will not be compromised or circumvented; that the product will prevent any personal injury or property loss by burglary, robbery, fire or otherwise, or that the product will in all cases provide adequate warning or protection. Buyer understands that a properly installed and maintained alarm may only reduce the risk of burglary, robbery or fire without warning, but is not insurance or a guaranty that such event will not occur or that there will be no personal injury or property loss as a result thereof. Consequently seller shall have no liability for any personal injury, property damage or loss based on a claim that the product fails to give warning. However, if seller is held liable, whether directly or indirectly, for any loss or damage arising under this limited warranty or otherwise, regardless of cause or origin, seller's maximum liability shall not exceed the purchase price of the product, which shall be complete and exclusive remedy against seller. No employee or representative of Seller is authorized to change this warranty in any way or grant any other warranty. **WARNING:** This product should be tested at least once a week.

**EN Technical Specifications**

	Receiver	Transmitter
<b>ELECTRICAL</b>		
Batteries	CR123A, 3.0V Lithium Battery	
Battery Life	3 years typical, depends on usage	
Current Consumption (normal mode)	0.5m unit:	60µA[AVR]@3V / 50µA[AVR]@3V
	1m unit:	100µA[AVR]@3V / 70µA[AVR]@3V
<b>RADIO FREQUENCY</b>		
RF Frequency	433.92/868.65MHz	
Modulation Type	ASK	
Address Codes	16 million	
<b>PHYSICAL</b>		
Size (L x W x D)	0.5m unit: 500 x 40 x 42 mm (19.6 in. unit: 19.6 x 1.5 x 1.6 in.) 1m unit: 1000 x 40 x 42 mm (39.3 in. unit: 39.3 x 1.5 x 1.6 in.)	
Weight	0.5m unit: 0.6kg (1.3lb) 1m unit: 1kg (2.2lb) without batteries	
<b>OPTICAL</b>		
Infrared Wave Length	-	
<b>ENVIRONMENTAL</b>		
Operation Temperature	-20°C to +60°C (4°F to 140°F)	
Storage Temperature	-25°C to +60°C (13°F to 140°F)	
RF Immunity	According to EN 50130-4	
IP Rating	IP65	

**IT Specifiche Tecniche**

	Ricevente	Trasmittente
<b>ELETRICHE</b>		
Batterie	Batterie al Litio CR123A, 3.0V	
Autonomia batterie	3 anni, in base all'uso	
Assorbimento (modalità Normale)	modello da 0,5m:	60µA[AVR]@3V / 50µA[AVR]@3V
	modello da 1m:	100µA[AVR]@3V / 70µA[AVR]@3V
<b>FREQUENZA RADIO</b>		
Frequenza RF	433,92/868,65MHz	
Tipo di modulazione	ASK	
Combinazioni per l'indirizzo	16 milioni	
<b>FISICHE</b>		
Dimensioni (L x A x P)	0,5m: 500 x 40 x 42 mm 1m: 1000 x 40 x 42 mm	
Peso	0,5m: 0,6kg 1m: 1kg Senza batterie	
<b>OTTICA</b>		
Lunghezza d'onda dell'infrarosso	-	
<b>AMBIENTALI</b>		
Temperatura operativa	Da -20°C a +60°C	
Temperatura di stoccaggio	Da -20°C a +60°C	
Immunità RF	Conforme alla norma EN 50130-4	
Classe IP	IP65	

**ES Especificaciones Técnicas**

	Receptor	Transmisor
<b>ELÉCTRICAS</b>		
Baterías	CR123A, Pila Litio 3 V	
Duración Batería	3 años, dependiendo del uso	
Consumo Corriente (modo normal)	Unidad 0,5 m:	60 µA [media] @ 3 V / 50 µA [media] @ 3 V
	Unidad 1 m:	100 µA [media] @ 3 V / 70 µA [media] @ 3 V
<b>RADIOFRECUENCIA</b>		
Frecuencia RF	433,92/868,65 MHz	
Tipo de Modulación	ASK	
Códigos de Dirección	16 millones	
<b>FÍSICAS</b>		
Tamaño (L x A x P)	Unidad 0,5 m: 500 x 40 x 42 mm (unidad 19,6": 19,6 x 1,5 x 1,6") Unidad 1 m: 1000 x 40 x 42 mm (unidad 39,3": 39,3 x 1,5 x 1,6")	
Peso	Unidad 0,5 m: 0,6 kg (1,3 lb) Unidad 1 m: 1 kg (2,2 lb) sin baterías	
<b>ÓPTICAS</b>		
Longitud Onda Infrarrojo	-	
<b>MEDIOAMBIENTALES</b>		
Temperatura Funcionamiento	-20°C a +60°C (4°F a 140°F)	
Temperatura Almacenamiento	-25°C a +60°C (13°F a 140°F)	
Inmunidad RF	Según EN 50130-4	
Índice de Protección	IP65	

**FR Spécifications Techniques**

	Récepteur	Transmetteur
<b>ELECTRIQUE</b>		
Batteries	Batterie Lithium CR123A, 3.0V	
Durée de vie de la batterie	3 ans en utilisation normale	
Consommation de courant (mode normal)	Unité de 0,5 m :	60µA[AVR]@3V / 50µA[AVR]@3V
	Unité de 1 m :	100µA[AVR]@3V / 70µA[AVR]@3V
<b>RADIO FREQUENCE</b>		
Fréquence RF	433,92/868,65MHz	
Type de modulation	ASK	
Codes d'adresse	16 million	
<b>PHYSIQUE</b>		
Taille (L x l x P)	Unité de 0,5m : 500 x 40 x 42 mm Unité de 1m : 1000 x 40 x 42 mm	
Poids	Unité de 0,5m : 0,6kg Unité de 1m : 1kg Sans batterie	
<b>OPTIQUE</b>		
Longueur d'onde IR	-	
<b>ENVIRONNEMENTAL</b>		
Température de fonctionnement	-20°C à +60°C	
Température de stockage	-25°C à +60°C	
Immunité RF	Selon la norme EN 50130-4	
Indice de protection IP	IP65	

**RTTE Compliance Statement:**  
 Hereby, RISCO Group declares that this equipment is in compliance with the essential requirements and other relevant provisions of Directive 1999/5/EC. For the CE Declaration of Conformity please refer to our website: www.riscogroup.com.

**Contacting RISCO Group**  
 RISCO Group is committed to customer service and product support. You can contact us through our website www.riscogroup.com or as follows:

<b>United Kingdom</b> Tel: +44-161-655-5500 technical@riscogroup.co.uk	<b>Spain</b> Tel: +34-91-490-2133 support-es@riscogroup.com	<b>USA</b> Tel: +1-631-719-4400 support-usa@riscogroup.com	<b>Brazil</b> Tel: +1-866-969-5111 support-br@riscogroup.com
<b>Italy</b> Tel: +39-02-66590054 support@riscogroup.it	<b>France</b> Tel: +33-164-73-28-50 support-fr@riscogroup.com	<b>Belgium</b> Tel: +32-2522 7622 support-be@riscogroup.com	<b>China</b> Tel: +86-21-52-39-0066 support-cn@riscogroup.com
			<b>Poland</b> Tel: +48-22-500-28-40 support-pl@riscogroup.com
			<b>Israel</b> Tel: +972-3963-7777 support@riscogroup.com

**FCC Note:**  
**Only the 433,92Mhz version is FCC approved and to be sold in US.**  
 The manufacturer is not responsible for any radio or TV interference caused by unauthorized modifications to this equipment. Such modifications could void the user's authority to operate the equipment.



All rights reserved. No part of this document may be reproduced in any form without prior written permission from the publisher.  
 © RISCO Group 02/10 5IN1326 B