

Notice about the law and the standard

High Speed Colour Printer

Model: HC5500T

This product contains RFID (Radio Frequency Identification) system.

Model: 444-59005

Contains FCC ID: RPARFMHL00

This device complies with Part 15 of the FCC Rules. Operation is subject to the following two conditions: (1) this device may not cause harmful interference, and (2) this device must accept any interference received, including interference that may cause undesired operation.

The user is cautioned that unauthorised changes or modifications not approved could void the user's authority to operate the equipment.

This equipment has been tested and found to comply with the limits for a Class B digital device, pursuant to part 15 of the FCC Rules. These limits are designed to provide reasonable protection against harmful interference in a residential installation. This equipment generates, uses and can radiate radio frequency energy and, if not installed and used in accordance with the instructions, may cause harmful interference to radio communications. However, there is no guarantee that interference will not occur in a particular installation. If this equipment does cause harmful interference to radio or television reception, which can be determined by turning the equipment off and on, the user is encouraged to try to correct the interference by one or more of the following measures:

- Reorient or relocate the receiving antenna.
- Increase the separation between the equipment and receiver.
- Connect the equipment into an outlet on a circuit different from that to which the receiver is connected.
- Consult the dealer or an experienced radio / TV technician for help.

Contains Canada IC: 4819A-RFMHL00

Operation is subject to the following two conditions: (1) this device may not cause interference, and (2) this device must accept any interference, including interference that may cause undesired operation of the device.

This Class B digital apparatus complies with Canadian ICES-003.

Cet appareil numérique de la classe B est conforme à la norme NMB-003 du Canada.



Countries of intended use

Austria/Belgium/Denmark/Finland/France/Germany/Greece/Iceland/Ireland/Italy/Luxembourg/Netherlands/Norway/Portugal/Spain/Sweden/Switzerland/U.K.

Copyright © 2006 RISO KAGAKU CORPORATION

Preface

Welcome to the world of this product!

This machine is an ink jet printer for high-speed full-colour printing that supports network. This printer allows various functions such as data output and printer monitoring to be used from Windows and Macintosh computers.

The following three manuals are provided for this machine.

- HC5500 Series User's Manual for Printer Main Body(this manual)
- HC5500 Series User's Manual for Printer Driver
- HC5500 Series User's Manual for Console
- RISO HC5500 Navigation Book

Before using this machine or when something is not clear during use, read the relevant manual to make good use of this machine for a long period.

About This User's Manual

Riso shall not be responsible for any damage or expense that might result from the use of this manual.

As we are constantly improving our products, the machine may differ in some respects from the illustrations used in this manual. Riso shall not be liable for any direct, incidental, or consequential damages of any nature, or losses or expenses resulting from the use of this product or included manuals.

Trademark Acknowledgments

Adobe[®], Adobe Type Manager[®], AdobePS[®], ATM[®], PostScript[®], PostScript^{®3™}, PostScript logo, and PageMaker[®] are trademarks or registered trademarks of Adobe Systems Incorporated.

AppleTalk[®], Macintosh[®] and Mac OS[®] are registered trademarks of Apple Computer, Inc. in the U.S.A. and other countries.

Microsoft[®], Windows[®] are registered trademarks of Microsoft Corporation in the U.S.A. and other countries.

ColorTune[®] is a trademark of Agfa-Gevaert N.V. registered at US Patent and Trademark Office and may be registered in other regions of jurisdiction.

ComColor[™], and FORCEJET[™] are trademarks of RISO KAGAKU CORPORATION.

 is a registered trademark of RISO KAGAKU CORPORATION in Japan and other countries.

All other product names and company names written in this manual are trademarks or registered trademarks of their respective companies.

About the Manuals

The following manuals are supplied with this machine.

- HC5500 Series User's Manual for Printer Main Body
Means this manual. This manual explains notes that should be known before starting operation of this machine, actual printing operation on the printer, and printer settings. This manual also explains the method of replacing consumables and troubleshooting.
- HC5500 Series User's Manual for Printer Driver
This manual explains the method of installing the printer and the installation procedure and the functions of the printer driver.
- HC5500 Series User's Manual for Console
This manual describes the "Monitoring" function that is used for checking the printer status through a network.
- RISO HC5500 Navigation Book
Explains useful functions and features in colour.

How to Read This Manual

Notation of Explanation of Operation

The following symbols are used in this manual for description of functions, operation, and notes.

ⓘ indicates items that should be noted or that are prohibited.

📖 indicates a title and page that should be referred to for understanding sufficiently an item. For referring to another operation manual, the name of the manual is also written.

🔍 indicates description concerning particularly useful information or information that should be known.

Menu 3 Temp Data Retrieve

The data currently retained in the printer can be retrieved and printed again by specifying the number of copies (additional printing).

ⓘ Retained data can be retrieved if a check mark is placed at [Keep the last page of the job in the printer.] in [Controller setting 2] - [Initial setting] of [Administrator] of PISO Console. For details, refer to "HC-5500 Series User's Manual for Console."

📖 p.62

The retained data is the last page of the latest printing. In the case of duplex printing, the data of the last sheet (two pages) is retained. When the printer enters the sleep mode, retained data will be cleared (not retained). The maximum number of copies that can be set for additional printing is "9999." If "4.9 Temp Data Clear" of the menu setting has been performed, message "No Temp Data" is displayed.

- 1 Press the MENU Key.
- 2 Press the Δ or ∇ key to display "Temp Data Retrieve."



- 3 Press the OK Key.
- 4 Press the \leftarrow / \rightarrow keys to move the cursor, and press the Δ / ∇ keys to input the number of copies for printing.

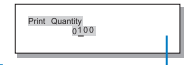

- 5 Press the OK Key.
- 6 Press the PRINT/ PAUSE Key. Printing of the set number of copies starts.

Paper jam occurs.

If a paper jam occurs in the printer or paper is not fed, printing stops, the **JAM** indicator, and the number indicating the jam location will light up. In this case, remove the jammed paper and press the PRINT/PAUSE Key, printing will resume. Since this unit performs high speed printing, paper jams may occur at multiple locations. In this case, remove all the jammed paper.

🔍 Paper Jam Location

Details of the indicated locations are shown below. For detailed procedure, refer to the respective indicated page.

Jam location	Page referred to
(1) Standard Paper Feed Tray	P. p.104
(2) On Transfer Roller	P. p.105
(3) Paper Receiving Section	P. p.105
(4) Right of Transfer Unit	P. p.106
(5) Duplex Transfer Unit	P. p.106
(6) Tray Left of Transfer Unit	P. p.108
(17) (18) In Paper Feed Tray 1 or 2	P. p.109
(20) Transfer Unit	P. p.110

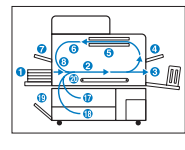

(1) Paper Jam in the Standard Paper Feed Tray

- 1 While pressing the Paper Release Lever on the paper feed side to the left, remove the paper.

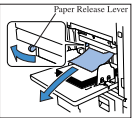

- 2 Press the CANCEL/BACK Key. The paper jam error is cleared.

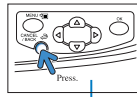

Used for describing the method of setting on the Operation Panel. Items to be changed are highlighted.

Operation procedure is described with illustrations.

⚠ **WARNING** and ⚠ **CAUTION** are cautions for safety. Be sure to read these items before using this machine.

Description for the name of Finisher (option)

A "Finisher" is used for description of a common matter by all finishers that are connectable to this machine. The peculiar name is used in description depending on the finisher's model.

Notation of Number of Sheets of Paper

In this manual, A4/85g/m² (22.6-lb bond) is used as a standard for description.

Example: Feed Tray 1 1,000 sheets



The value varies with the paper.

Safety Precautions





This section describes the items that should be followed for safe use of this machine. Be sure to read this section.

Warning Symbols

To use the machine properly and to prevent human injury and damage to properties, the following warning symbols are used. Read the meaning of the symbols to understand and then read this manual.

 WARNING	Indicates that incorrect handling by ignoring this symbol may cause death or serious human injury.
 CAUTION	Indicates that incorrect handling by ignoring this symbol may cause human injury or damage to properties.

Example of icons

	The  symbol indicates a prohibited action. A concrete prohibited action is drawn in the symbol or near the symbol. (The left figure shows prohibition of disassembly.)
	The  symbol indicates a forced action or an instruction. A concrete instruction is drawn in the symbol. (The left figure shows an instruction to remove the power plug from the electrical outlet.)

Location for Installation

CAUTION

- Place the machine on a flat or stable surface. Otherwise, the machine might be inclined or fall down, resulting in human injury.
- The machine has vent holes. Install the machine more than 100 mm (3¹⁵/₁₆"') away from the wall. If the vent holes are blocked, heat is not dissipated and a fire might occur.
- Do not place the machine in a dusty or humid location. Otherwise, a fire or an electric shock might occur.
- Do not place the unit in a location that is subject to water leak or water splashes. If water enters the unit, a fire or an electric shock might occur.

Power Connection

WARNING

- Install the machine near the wall socket to avoid using an extension cord between the machine and the wall socket. If an extension cord is absolutely required, do not use longer than 5m (15ft). Otherwise, a fire or an electric shock might occur.
- Do not damage or rebuild the power cord. Placing a heavy object on the cord or pulling or bending forcibly the cord may damage the cord, resulting in a fire or an electric shock. 
- The power cord supplied with this product can be used only for this machine. Do not use it for another electric product. A fire or an electric shock might occur.
- Do not plug or unplug the power cord if your hands are wet. Otherwise, an electric shock might occur.

CAUTION

- Do not pull the power cord when unplugging it. Otherwise, it could become damaged and a fire or an electric shock might occur. Be sure securely to hold on to the plug before unplugging it.
- If the machine is not used for a long time, for example due to consecutive holidays, unplug the power cord from the electrical outlet for safety.
- Pull out the power plug from the electrical outlet more than once a year and clean the prongs of the plug and their surroundings. Dust collected on these areas can result in fire.

Handling

WARNING

- Do not place water containers or metallic objects on the machine. If water drips inside the machine or a metallic object drops inside it, a fire or an electric shock might occur.
- Do not place any bare fire source such as candle on the unit.
- Do not insert or drop any metallic material or flammable substances into the machine through any opening. A fire or an electric shock might occur.
- Do not remove the covers. Otherwise, you might be electrically shocked by the high-voltage part inside.
- Do not disassemble or rebuild the machine by yourself. Otherwise, a fire or an electric shock might occur.
- If the machine emits excessive heat, smokes or foul odour, immediately turn off the power, unplug the electrical (power) cord and contact your service representative because a fire or an electric shock might occur.
- If something drops inside the machine, immediately turn off the Main Power Switch, unplug the electrical (power) cord and contact your service representative. If you continue using it, a fire or an electric shock might occur.



CAUTION

- Never stick your hands or fingers in the openings around the Standard Feed Tray and the Paper Receiving Tray during operation. Otherwise, human injury might occur.
- Ink may be stuck to the inside of the machine. Take care not to touch it with your hands or clothes. If your hands or clothes are stained with the ink, wash it off immediately with a detergent.
- When moving the machine, contact your service representative. If you try to move the machine by force, the machine might turn over, resulting in human injury.
- **When the HC Auto stacker is connected to the printer.** Never stick your hands or fingers in the openings around the Shift Tray during operation. Otherwise, human injury might occur.

Handling of Ink

CAUTION

- Avoid contact of ink with your eyes and skin. If ink gets into your eyes, flush it out immediately with plenty of water. If ink comes into contact with your skin, wash it off thoroughly with soap.
- Allow plenty of ventilation during printing. If you feel unwell during use, immediately move to a location with fresh air.
- If you feel sick, seek medical advice immediately.
- Only use the ink for printing purposes.
- When carrying the Ink Cartridge, hold its main body. Otherwise, the cap may be removed and the Ink Cartridge may drop, resulting in stain on your hands or clothes.
- Do not put a used Ink Cartridge into fire. Since the ink is flammable, a flame may become large, resulting in a burn.
- Keep the Ink Cartridge out of the reach of children.

Before Starting to Use

This section explains precautions you have to observe when using the machine.

Location for Installation

- The location for installation is determined based on consultation with the customer at the time of delivery.
- Contact your service representative before moving the machine.
- Avoid installing the machine in the locations listed below. Failure to observe this precaution may lead to machine failure or human injury.
 - Locations that are subject to sudden temperature change.
 - Extremely hot and humid locations or cold and dry locations
 - Heated locations or locations to exposed to direct cold air, direct hot air, or direct radiant heat
 - Badly ventilated locations
 - Dusty locations
 - Locations that are subject to frequent vibration

Operation Environment

- Install the machine in a location of which the levelness meets the following conditions.
 - Front to rear: 3 mm ($\frac{1}{8}$ ") or less
 - Side to side: 3 mm ($\frac{1}{8}$ ") or less
- Appropriate environment conditions are shown below.
 - Temperature range: 15°C - 30°C (59°F to 86°F)
 - Humidity range: 40% - 70%(noncondensing)

Overall Dimensions

Space for extending the Standard Feed, Paper Receiving and space for pulling out Feed Trays are required.

 The dimensions are expressed in mm (inch).

● Front view

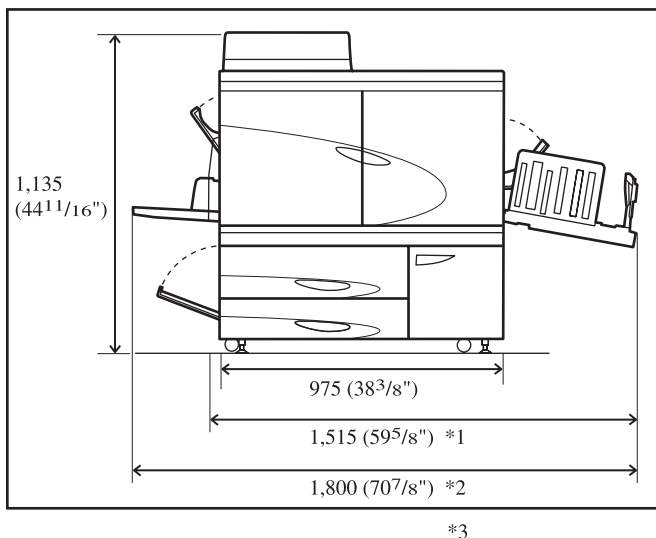

● Side view

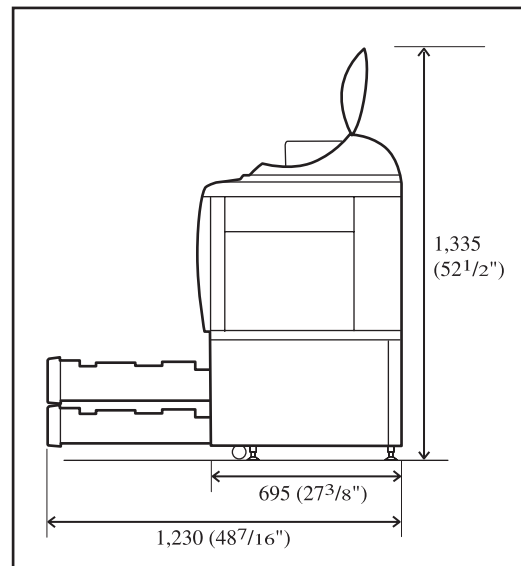

* When the HC Auto Stacker is connected.

*1 1,782 (70 $\frac{3}{16}$ ")

*2 1,875 (73 $\frac{7}{8}$ ")

*3 2,020 (79 $\frac{9}{16}$ ") When the HC Auto Stacker is removed from the Printer for a recovery of paper jam.

Handling of The Machine

- Do not turn off the Main Power Switch or unplug the electrical (power) cord during operation.
- Do not open any covers during operation.
- Do not move the machine.
- The machine has precision parts and driving parts inside. Do not handle the machine in other ways than described in this manual.
- Contact your service representative before moving the machine.
- Do not place heavy objects on or apply shocks to the machine.
- Be sure to open and close any cover gently.
- When turning off the Main Power Switch of the machine and then turning it on again, wait more than 10 seconds before turning it on.
- If the machine will not be used or has not been used for a long time, be sure to perform Ink Head Maintenance (normal cleaning). Otherwise, deterioration or drying of ink occurs in the ink transfer path inside the machine, resulting in clogging at the head. To prevent this problem, periodic use is recommended.
- Never touch the print head because a failure or deterioration of images may occur.
- Be sure to use always the machine with the four ink cartridges mounted. Even if some ink cartridge is not used, do not leave the machine with an ink cartridge removed.

Handling and Storage of Ink Cartridge

- Do not shake the Ink Cartridge before use. Air bubbles may occur, resulting in defective printing.
- Do not add ink into the Ink Cartridge.
- If ink remains for a long time after the cartridge is opened, the ink may be deteriorated because of various components contained in the air. Use of deteriorated ink may cause a failure of the print head or the ink transfer path.
- The injection characteristic of the ink jet printer varies with viscosity of the ink. At a low temperature, particularly, the viscosity increases and clogging of the print head may occur. Observe the operation environment and storage temperature, and use the ink earlier checking the date of manufacture.
- The adequate operation temperature of the machine is 15°C - 30°C (59°F to 86°F) Use of the machine out of the adequate temperature range may cause defective printing (decrease of discharge).
- Do not release the ink left in the cartridge into a sewer.
- Do not keep Ink Cartridge with its nozzle downward.
- Store under conditions which avoid freezing or direct sunlight, and temperatures of 5°C (41°F) or lower, and 35°C (95°F) or higher. Also use the ink earlier checking the date of manufacture.

Handling and Prints of Paper

- Be sure to load paper that is not curled.
- Be sure to store unused paper to avoid humidity by wrapping it with packing paper.
- In duplex printing, the edges of paper may be stained depending on the original.
- Prints are discoloured by influence of various components in the air and light. If prints are dried sufficiently and then put in a frame with glass or is laminated for storage, discolouration becomes small.
- When storing prints in a clear file, use a file made of PET.
- Prints are decolourized by moisture or sweat. Avoid storage in a location exposed to waterdrops. Also writing with an oil-based pen may cause bleeding.
- The printing density differs between prints immediately after printing and those 24 hours after printing. Note that the density decreases as the time elapses.

- Do not stack prints on other prints that are output with a laser printer or a copier that uses toner. Paper may be stuck to the portions printed with toner or toner may be transferred to the prints.
- Store paper flat avoiding high temperature, high humidity, and direct sunlight. Note that the curled paper cannot be used.

Disposal of Ink Cartridge and Ink Drain Tank

- The ink may leak through the ink feed opening of the cartridge. When returning, attach the cap and put the cartridge into the inner bag and the packing material.
- Used Ink Cartridges and Ink Drain Tanks are collected by a service representative. After use is complete, close the cap securely.
- Ink in the ink drain tank cannot be used for printing. A failure or trouble may occur.

Print Area (Image Area)

Regardless of the original paper size, printing cannot be performed on a part of paper along the sides of the paper. Since use of paper of the same size as the original leaves margins, the full area of the paper is not used for printing. To print an original on which characters or figures occupy the full area, reduce the full area of the original and then perform printing.

When printing onto an envelope, the print area is different. Refer to "Printing onto Envelope." p.1-21

Guaranteed Print Area (Image Area)

Printing can be performed into the area 5 mm ($\frac{3}{16}$ ") inside from the sides of paper.

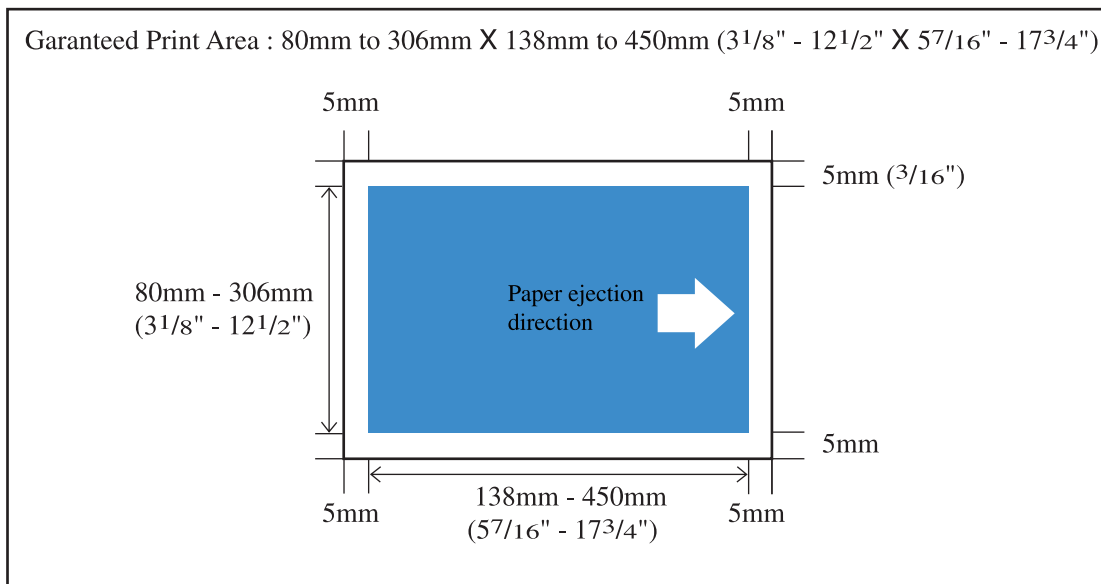

Maximum Print Area (Image Area)

When an original is scanned through the optional scanner, printing can be performed into the area inside 1 mm (0.04") from the sides of paper but deterioration of print quality such as loss of characters or figures and bleeding may occur depending on the original.

Even if the paper size is larger than 316mm × 460mm ($12\frac{7}{16}$ " × $18\frac{1}{8}$ "), the actual maximum printable area is 314mm × 458mm ($12\frac{3}{8}$ " × $18\frac{5}{16}$ ").



- "4.10 Image Area" of the menu setting must be set. "4.10 Image Area" p.2-29
- Depending on the application, it may not be possible to make a margin of 1 mm (0.04") width along the edges of paper. (In most application software, margin width of 5 mm ($\frac{3}{16}$ ") is required.)

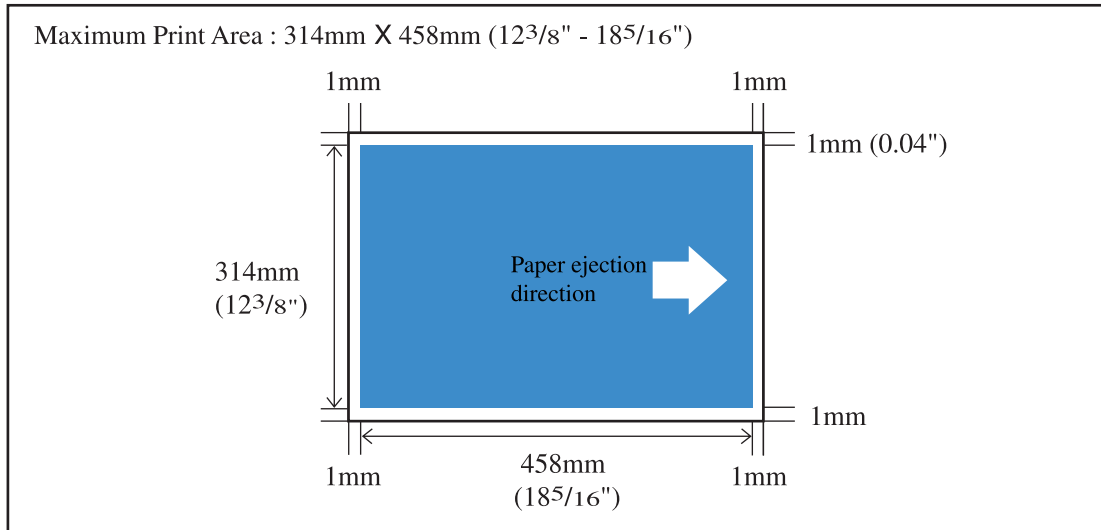

Materials Not to Be Printed

Do not use the machine in any manner which violates the law or infringes on established copyrights, even when making copies for personal use. Consult your local authorities for further details. In general, use discretion and common sense.

Power Connection

- Connect the power plug securely to the electrical outlet to avoid improper connection.
- Install the machine near the electrical outlet.
- If an optional device is connected to an electrical outlet for option connection on the machine, the optional device is turned on and off at the same time as the machine.
- Use only the power cord supplied by the seller of the controller, or use a cord that is earthed, not longer than 4.5m, rated not less than the controller is rated, and authorized by the state or region where it is used.

Sleep

When the machine is on and is not used for a certain time, the machine enters automatically the energy saving mode. Two types of energy saving mode are provided: Stand-by mode and Sleep mode.

- Stand-by mode: Power consumption is 150 W or less.
When data is received from a computer, the machine enters the print mode.
To turn on the print mode from the operation panel of the printer, press the WAKE-UP Key.
- Sleep mode: Power consumption is 200 W or less.
To enable reception of data, perform startup operation from a computer.
To start up from the operation panel of the printer, press the Sleep Key.

The energy saving function is set in "Menu 5 Administration" on the operation panel.

If the machine is not used for a long time, turn off the Main Power Switch and remove the power plug from the electrical outlet. (When the Main Power Switch is turned off, the power consumption becomes 0 W.)

Connecting to a Computer

The machine is connected to a computer through network.

- When connecting the machine to multiple computers:

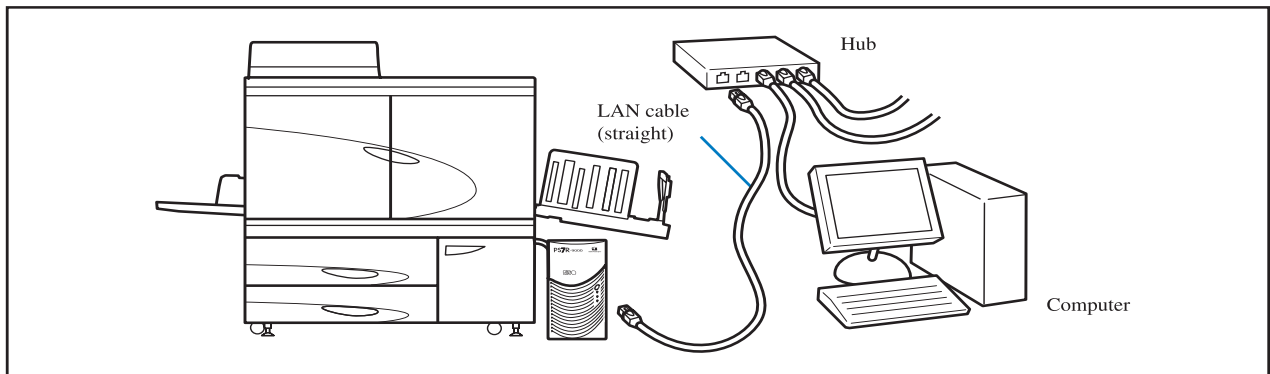

- When connecting the machine to a single computer:

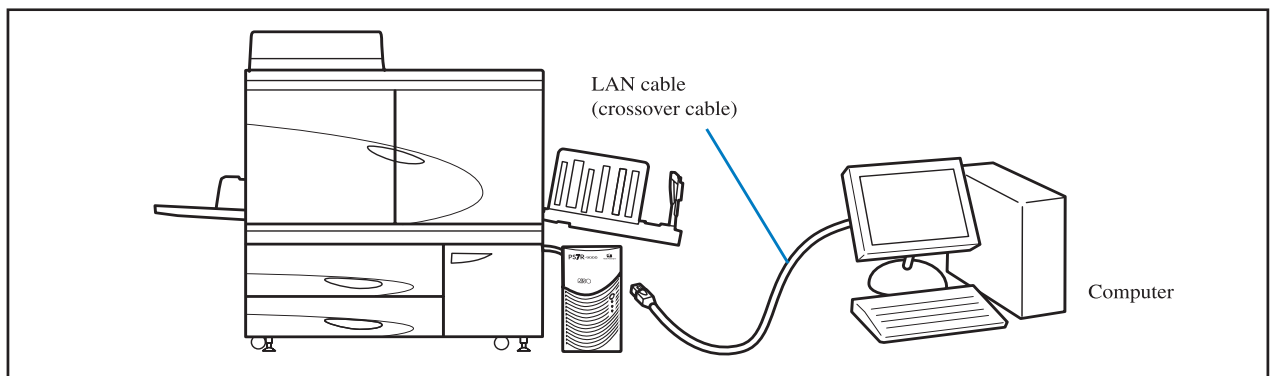

! The allowable voltage for all input/output connections is 5V.

! Use a commercially available S/UTP cable (shielded or non-shielded twisted pair cable) as a LAN cable.

Notice for European Union Member States

RISO, the environment and the Waste Electrical and Electronic Equipment Directive "WEEE Directive"

What is the WEEE Directive?

The purpose of the WEEE Directive is to reduce waste and ensure Electrical and Electronic Equipment is recycled at the end of its useful life.



What does the crossed out wheeled bin symbol mean?

The crossed out wheeled bin symbol indicates this product must be disposed of separately to normal waste.

Please contact your RISO service agent for information about disposal.

What does the solid bar symbol mean?

The solid bar under the crossed out wheeled bin indicates this product was put on the market after the 13th August 2005.

Who should I contact if I want more information about the WEEE Directive?

You should contact your local RISO service agent for more information.

Chapter1 Basic Information on Printing1-1

Describes names and functions of parts of the printer, preparation for printing, and general printing operation.

Names of Parts	1-2
Printer Main Body	1-2
Main Body (rear view)	1-4
Control Panel	1-5
HC Auto Stacker (option)	1-6
Preparing to Print	1-7
Usable Paper	1-7
Power Switch	1-10
Loading Paper	1-11
Setting Up the Paper Receiving Tray	1-16
Basic Printing Operation	1-18
Print Operation Flow	1-18
Printing from the Computer (Windows)	1-18
Printing onto Envelope	1-21
Envelope Size and Maximum Print Area (Image Area)	1-21
How to Print	1-22
When Printing is Complete	1-24

Chapter2 Printer Configuration2-1

Describes the functions that can be set from the Operation Panel and their method of operation.

Message Display and Operation Keys	2-2
Message Display	2-2
Operation Keys	2-4
How to Use the Operation Panel	2-5
Items That Can Be Set from the Menu	2-5
Basic Operation of Menu Selection	2-10
Menu 1 Print Position Adjust	2-14
Menu 2 Test Print	2-16
Menu 3 Temp Data Retrieve	2-17
Menu 4 Configuration	2-18
4.1 Standard Feed Tray/ 4.2 Feed Tray 1/ 4.3 Feed Tray 2	2-19
4.4 Feed Tray Relay	2-21
4.5 Triple-Tray Source	2-22
4.6 Job Separation	2-23
4.7 Print Density	2-24
4.8 Paper Ejection	2-25
4.9 Temp Data Clear	2-28
4.10 Image Area (Maximum Print Area)	2-29
4.11 Cover Sheet Tray (Only when the HC Finisher is connected)	2-30
Menu 5 Administration	2-31
How to Enter the Administration Menu	2-31
5.1 Paper Size Entry	2-32
5.2 Paper Type Entry	2-33
5.3 Separation Paper	2-36
5.4 Count Management	2-37

5.5 Head Maintenance	2-40
5.6 Configuration Information Print	2-42
5.7 Network Configuration	2-45
5.8 Initial Setting	2-46
Menu 6 Feed Tray Selection	2-54
Menu 7 Job Clear	2-55

Chapter3 Troubleshooting 3-1

Describes the causes of and measures against trouble indicated with an error message displayed on the Operation Panel or a lighting symbol.

Explanation of Set Error Display	3-2
Remaining Volume Notice Indicators	3-2
FORCEJET™ Link Symbol	3-3
Error Message and Error Number	3-3
Paper jam occurs	3-9
(1) Paper Jam in the Standard Paper Feed Tray	3-9
(2) Paper Jam on the Transfer Roller	3-10
(3) Paper Jam in the Paper Receiving Section	3-10
(4) Paper Jam in the Right of the Transfer Unit	3-11
When the HC Auto Stacker is connected.	3-11
(5) Paper Jam in the Duplex Transfer Unit	3-12
(6)(7)(8) Paper Jam in the Left of the Transfer Unit	3-14
(17)(18)(19) Paper Jam in Paper Feed Tray 1/ Paper Feed Tray 2	3-15
(20) Paper Jam in the Transfer Unit	3-16
(21) Paper Jam in HC Auto Stacker (option)	3-17
Ink Cartridge Replacement	3-18
Ink Cartridge	3-18
Other Trouble	3-20
The printer does not operate.	3-20
The printer does not operate according to the setting.	3-21
Printing is not clean.	3-21
Others	3-22

Chapter4 Appendix 4-1

Shows the list of consumables and the specifications.

List of Options	4-2
RISO Scanner HS2000	4-2
Finisher Functions	4-2
HC Auto Stacker	4-2
Consumables	4-3
Ink Cartridge	4-3
Specifications	4-4
Index	4-8

Chapter1 Basic Information on Printing

This section describes names and operation of parts that should be known for using the printer and general printing operation.

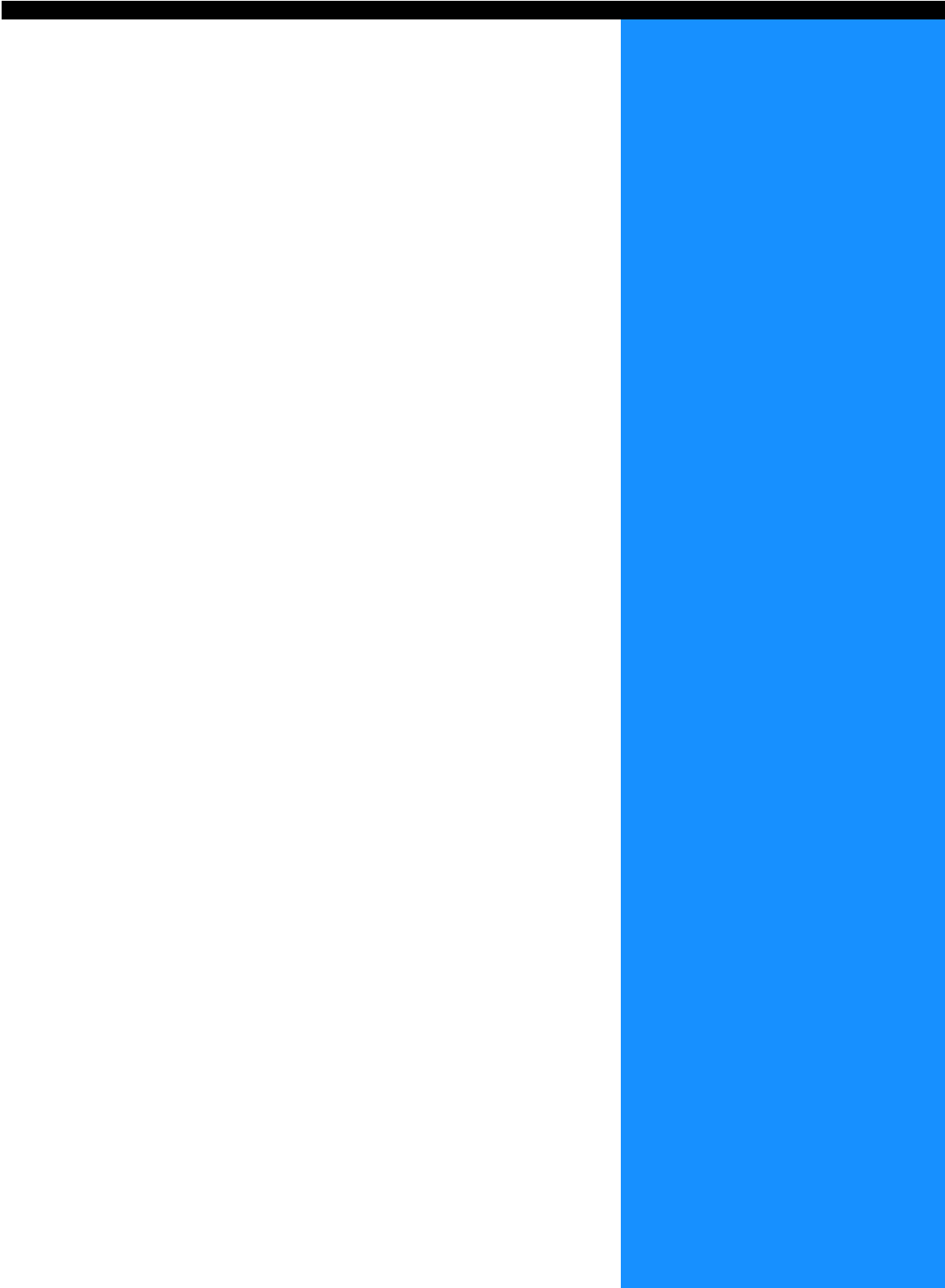

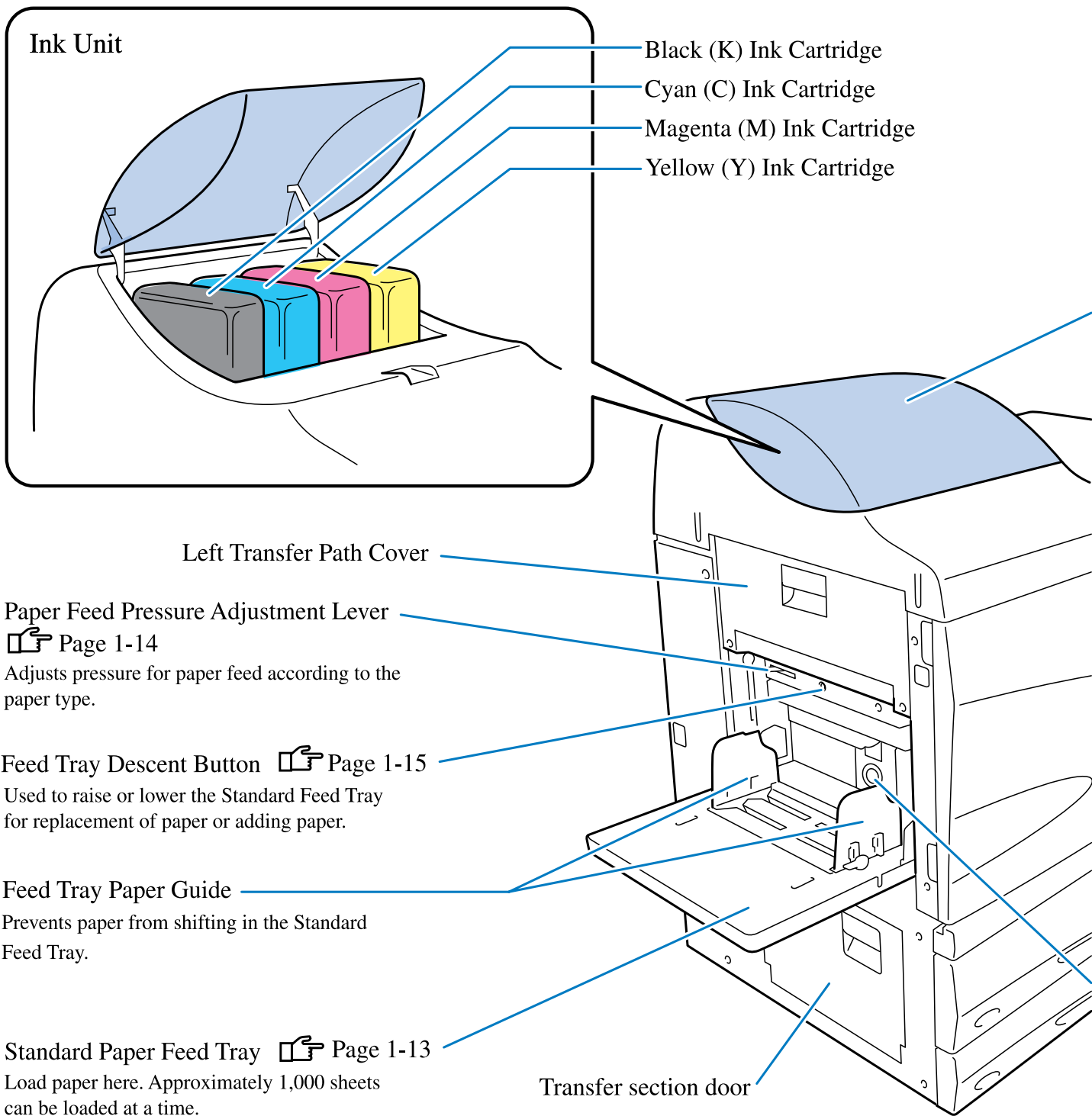

Names of Parts

Printer Main Body

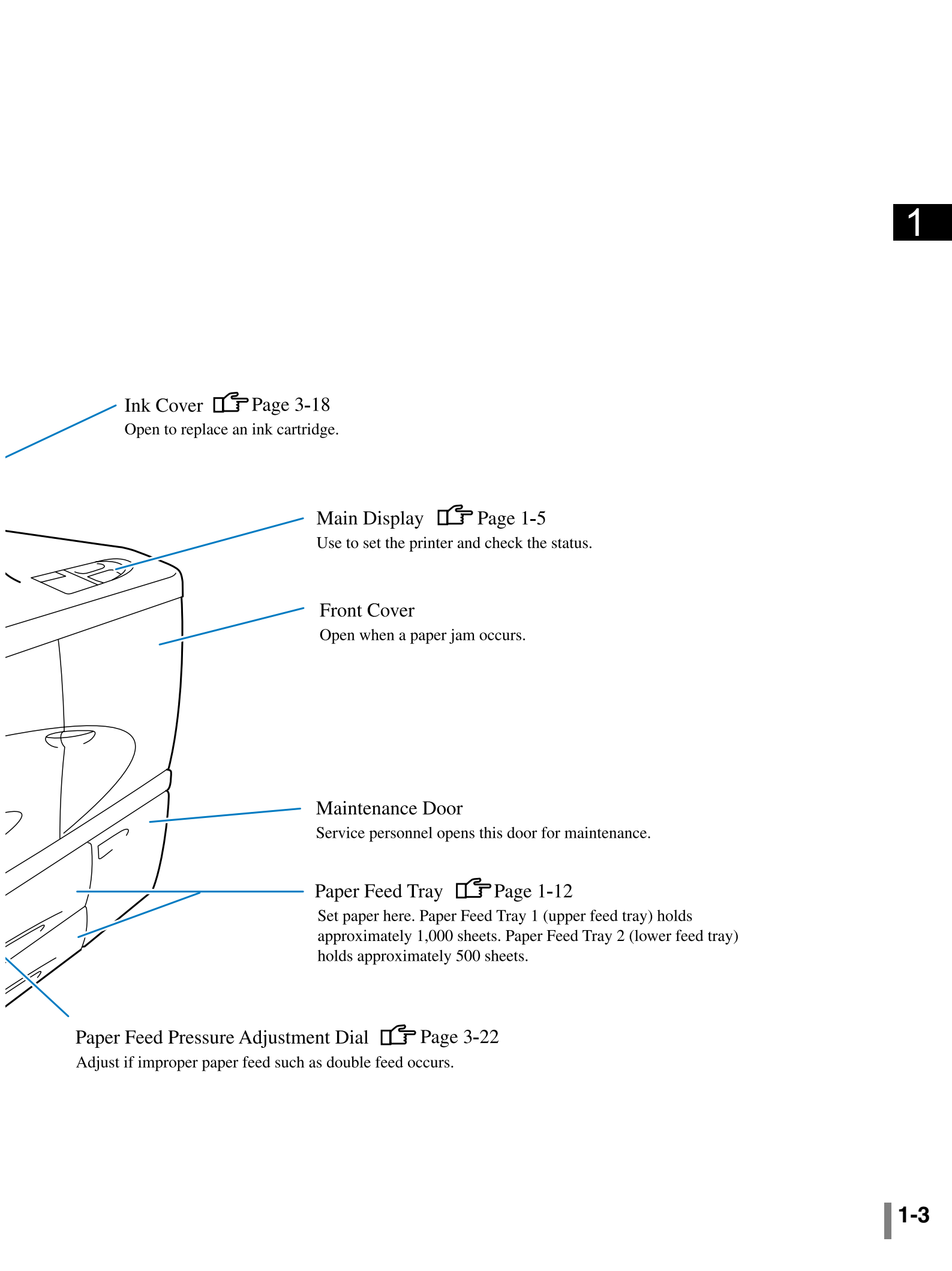





Ink Cover  Page 3-18
Open to replace an ink cartridge.

Main Display  Page 1-5
Use to set the printer and check the status.

Front Cover
Open when a paper jam occurs.

Maintenance Door
Service personnel opens this door for maintenance.

Paper Feed Tray  Page 1-12
Set paper here. Paper Feed Tray 1 (upper feed tray) holds approximately 1,000 sheets. Paper Feed Tray 2 (lower feed tray) holds approximately 500 sheets.

Paper Feed Pressure Adjustment Dial  Page 3-22
Adjust if improper paper feed such as double feed occurs.

Main Body (rear view)

Paper Arranger



Page 1-16

Set them so that ejected paper is arranged neatly.

Stack Guide (side)

Stack Guide (end)



Page 1-16

Prevents paper from shifting in the Paper Receiving Tray.

Stack Guide Open Button



See below.

Auto-Control Stacking Tray



Page 1-16

Paper Receiving Tray that adjusts automatically the Stack Guide positions according to the paper size.

Main Power Switch



Page 1-10

Turns on or off the power.
Normally keep it on.

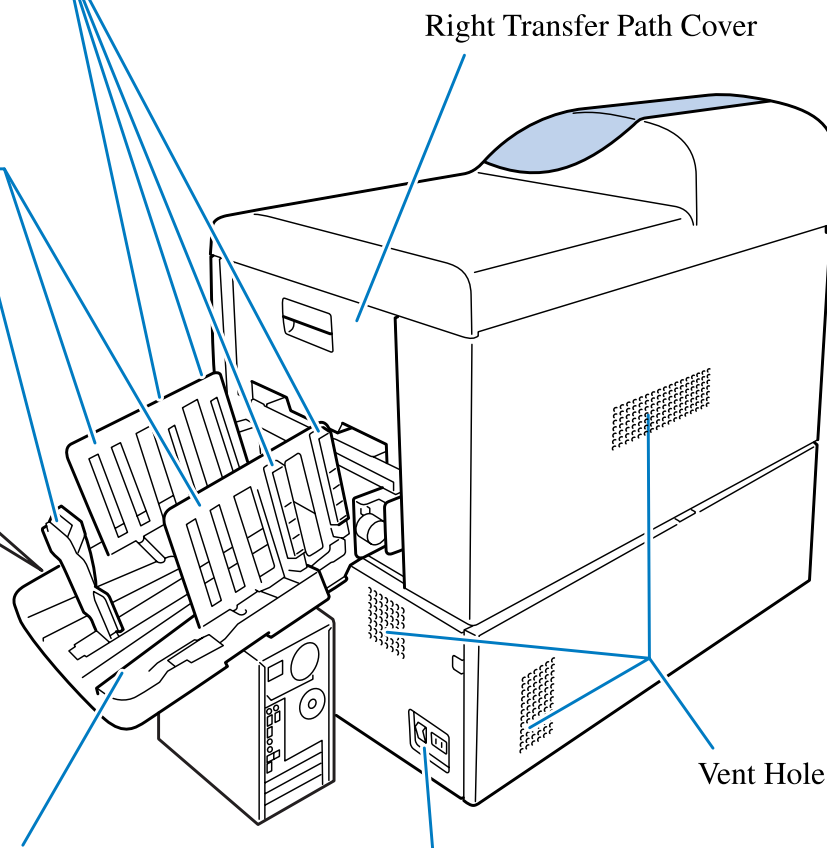
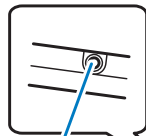

Stack Guide Open Button

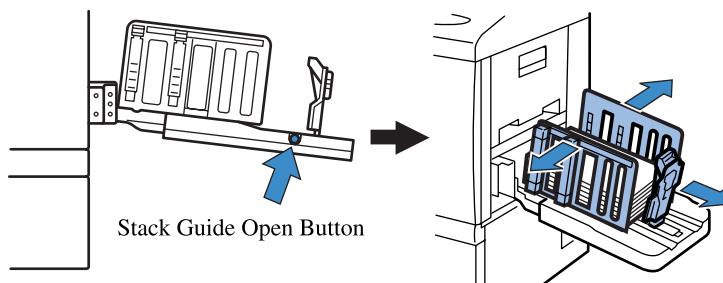

When removing printed paper from the Paper Receiving Tray, press this button to spread the Stack Guides for easy removal.

The guides to be spread can be set. For details, refer to "4.8.4 Shifting Guide" of the menu setting . p.2-27

Control Panel

The Control Panel includes a message display, setting and trouble display, and operation keys. For description of each display and detailed operation methods, refer to "Chapter 2 Printer Configuration" p.2-1.

FORCEJET™ Link symbol
Page 3-3

Remaining Volume Notice
Indicators
Lights up when ink or paper is low.

Message Display Page 2-2
Displays the printer status, description of an error,
setting items, etc.

WAKE-UP key Page 1-10
Restores the printer from the sleep mode.

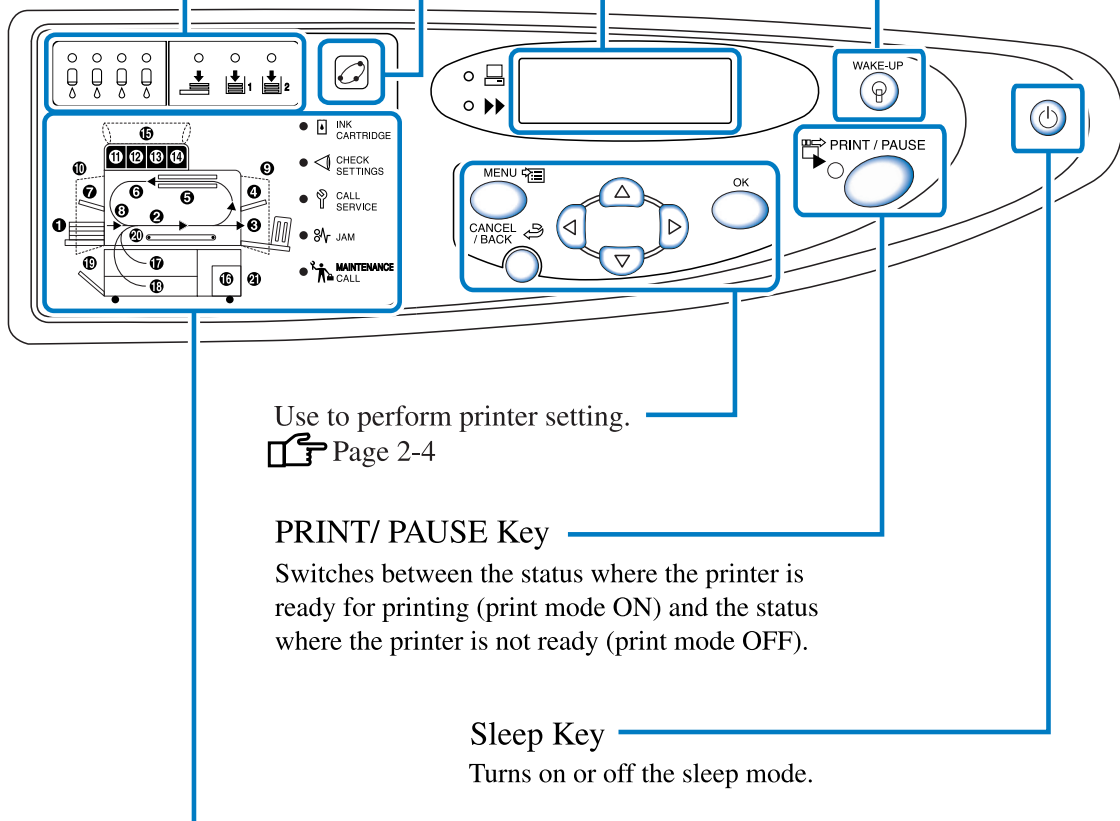

Use to perform printer setting.
Page 2-4

PRINT/ PAUSE Key
Switches between the status where the printer is
ready for printing (print mode ON) and the status
where the printer is not ready (print mode OFF).

Sleep Key
Turns on or off the sleep mode.

Indicates the description and location of an error when a
paper jam occurs inside or a cover is not securely closed.
Page 3-3

HC Auto Stacker (option)

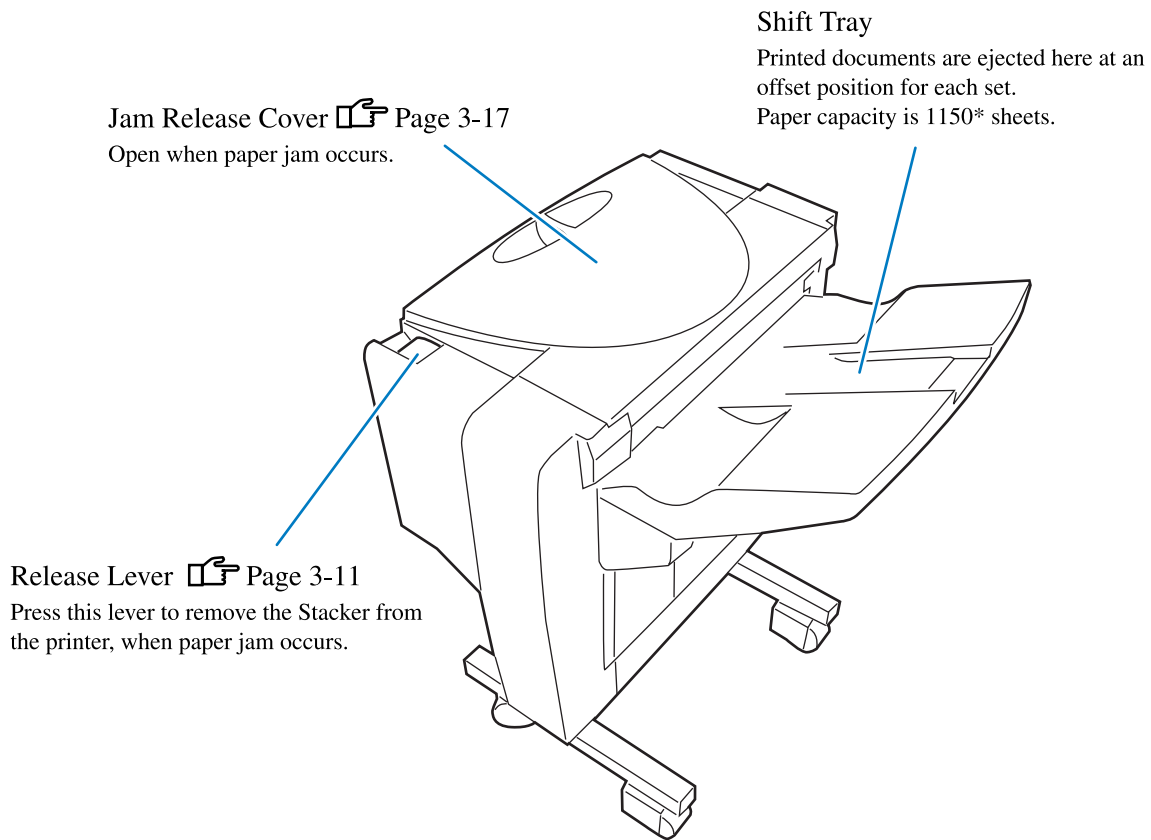

CAUTION

Never stick your hands or fingers in the openings around the Shift Tray during operation. Otherwise, human injury might occur.

*It varies according to the size, orientation, and type of paper.

Preparing to Print

After connection of the printer to a computer or network is complete, prepare paper and the Paper Receiving Tray for printing.

Usable Paper

This section describes usable paper and unusable paper.

Use of paper that is not adequate for the printer may cause paper jams, stains or a failure.

Use paper that conforms to the following specifications.

 The print quality differs depending on the paper type.
Use recommended paper adequate for HC5500. For details, contact your dealer.

Basic Specifications of Paper

Paper that conforms to the following restrictions can be used for printing.

● Paper weight

For Standard Paper Feed Tray	46g/m ² - 210g/m ² (12-lb bond to 56-lb bond)
For Paper Feed Trays	52g/m ² - 104g/m ² (14-lb bond to 28-lb bond)

● Paper Sizes That Can Be Used in the Standard Feed Tray

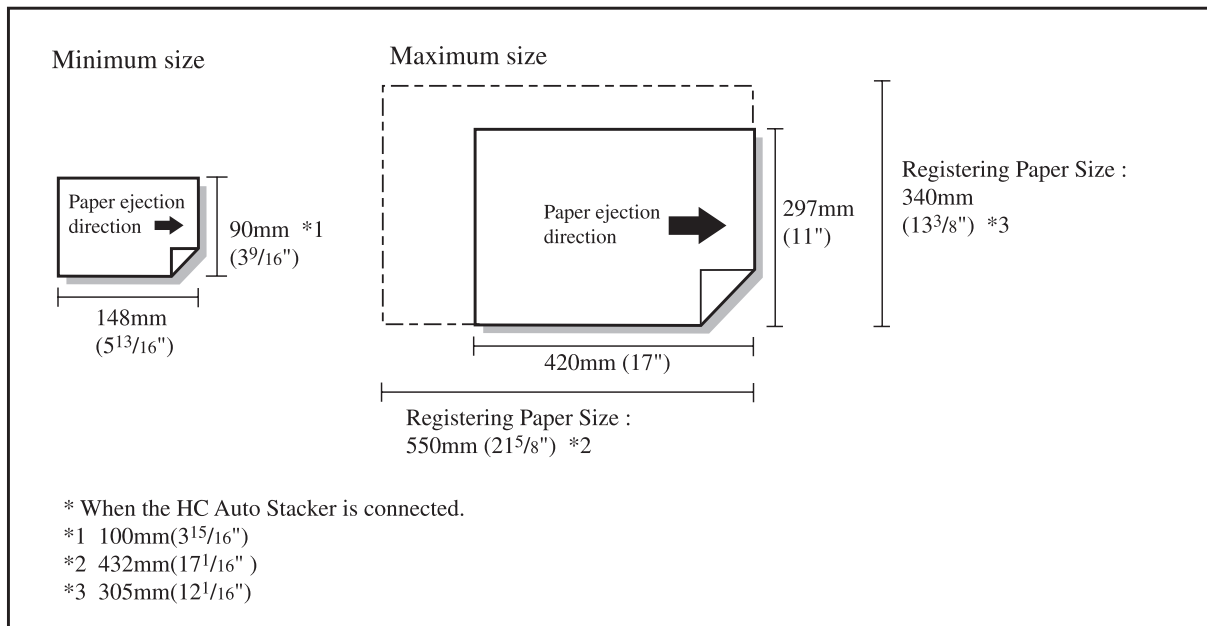

 When using an envelope, set it in the Standard Feed Tray. "Printing onto Envelope" [p.1-21](#)

Registering Paper Size and Paper Type

If non-standard size paper or paper larger than A3/Ledger is used in the Standard Feed Tray, the paper size and the paper type must be registered in advance.

"5.1 Paper Size Entry" [p.2-32](#)

"5.2 Paper Type Entry" [p.2-33](#)

When using paper larger than the A3/Ledger size, set "4.8.2 Stack Guide" of "4.8 Paper Ejection" of the menu setting to "OFF" and fold the stack guides before printing. "4.8.2 Stack Guide" [p.2-26](#)

● Paper Sizes That Can Be Used in Paper Feed Tray 1/Paper Feed Tray 2

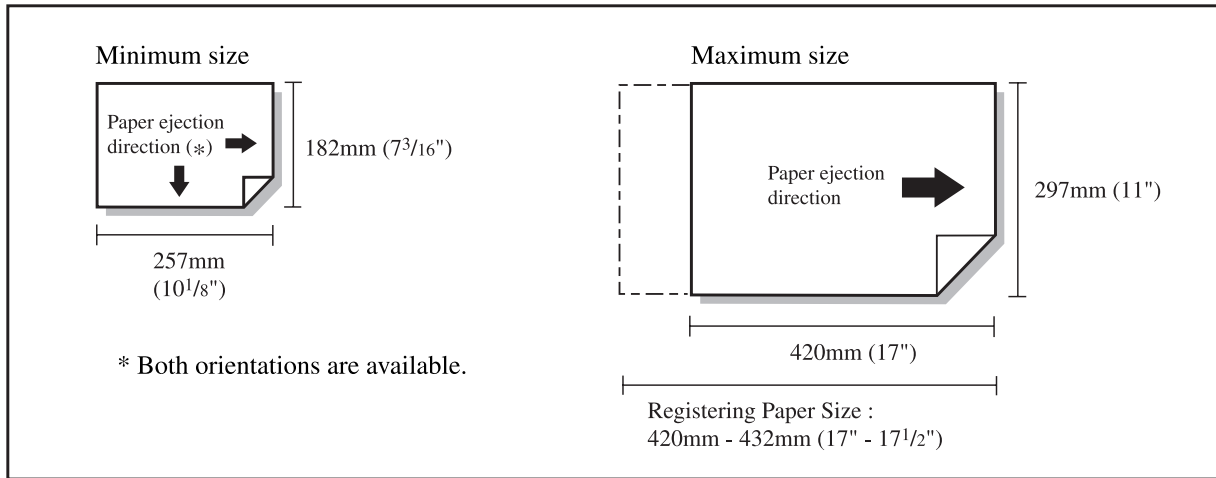

Registering Paper Size and Paper Type

If non-standard size paper is used in Feed Tray 1/Feed Tray 2, the paper size and the paper type must be registered in advance.

"5.1 Paper Size Entry" p.2-32

"5.2 Paper Type Entry" p.2-33

If a registered paper size is not adequate for the feed tray, the paper will not be displayed as a choice in the menu setting.



Note that even if "paper size" and "paper weight" conform to the specifications of this machine, paper may not be properly fed depending on the paper type, environment, and storage conditions. For details, contact your local dealer (or service representative).

Unusable Paper

Do not use paper shown below because it may cause paper jams.

- Paper thinner than specified in the basic specifications
- Paper thicker than specified in the basic specifications
- Chemically treated or coated paper (such as thermal or carbon paper)
- Warped paper
- Wrinkled paper
- Folded paper
- Torn paper
- Curled paper (Curled is 3mm (¹/₈") or more)
- Front or back coated paper such as art paper and commercially available paper for ink jet printer
- Paper with serrated edge
- Paper with adhesive
- Paper with holes
- Commercially available matted paper
- Glossy paper for photo

Handling of Paper

- For printing paper, use recommended paper wherever possible. Recommended paper allows high-quality printing that makes full use of the printer performance and the characteristics of ink.
- When loading paper in the Standard Feed Tray, be sure to use paper that has not been unpacked. After completing printing, store paper left in the Standard Feed Tray by wrapping it with packing paper. If the paper is left in the Standard Feed Tray, the paper may be curled, resulting in paper jams.
- When using badly cut paper or rough surface drawing paper, fan the paper sufficiently before use.
- Store paper in a dry location.

Power Switch

⦿ Main Power Switch and Sleep Key

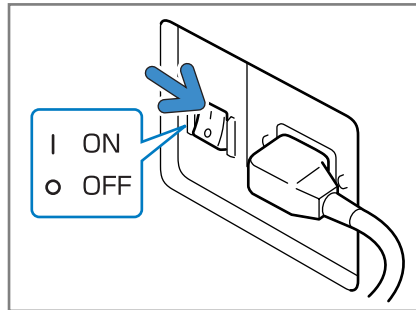

Main Power Switch
(lower right of main body)

The Main Power Switch is used to turn on or off the whole printer. If the printer is not used for a long time, for example due to consecutive holidays, turn off the Main Power Switch.

Turn on or off the Sleep key when starting or terminating daily work. If this unit is not used for a certain time with the Sleep Key on, this unit automatically enters the sleep mode for suppressing power consumption. "5.8 Initial Setting" p.2-46



- When Turning on the Power:
Turn on the Main Power Switch and then press the Sleep Key.
- When Turning off the Power:
Press and hold down the Sleep Key more than approximately one second and turn off the Main Power Switch after message "Shutting Down" on the message display disappears.
When turning on the Main Power Switch again, wait more than 10 seconds.
- Power ON/OFF status can be checked with the colour of the Sleep Key.

Status	Indicator on the operation panel	
Active	<p>Sleep Key: Lit green WAKE-UP Key: Not lit</p>	Ready to print.
In Stand-by mode	<p>Sleep Key: Lit green WAKE-UP Key: Lit</p>	Press the WAKE-UP Key to activate the printer.
In Sleeping mode	<p>Sleep Key: Lit orange WAKE-UP Key: Not lit</p>	Press the Sleep Key to activate the printer.

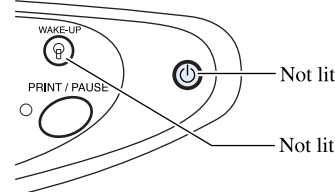
Status	Indicator on the operation panel	
OFF	 <p>Sleep Key: Not lit WAKE-UP Key: Not lit</p>	Turn the Main Power Switch on and press the Sleep Key.

Loading Paper

The method of loading paper in the Paper Feed Trays and the Standard Paper Feed Tray is described below.

Number of Sheets That Can Be Loaded

The number of sheets* that can be loaded in the Feed Trays and the Paper Feed Tray are shown below. The number of sheets that can be loaded varies with the thickness of paper.

*When 85g/m² (22.6-lb bond) is used:

Paper Feed Tray 1	1,000 sheets
Paper Feed Tray 2	500 sheets
Standard Paper Feed Tray	1,000 sheets

Paper to Be Loaded in the Standard Paper Feed Tray

When using paper shown below for printing, load the paper in the Standard Paper Feed Tray with the print face up.

- Special paper such as thick paper
- Paper for which printing has been performed onto the back side
- Paper larger than A3/Ledger size
- Paper smaller than B5 size such as postcard
- Envelope



When using the Standard Paper Feed Tray, be sure to load paper just after opening the package. (We recommend you to use good conditioned paper such as no-curl.) After printing, return paper remaining on the Standard Paper Feed Tray to the original package. Leaving paper on the tray may cause curling, possibly resulting in paper jam.

Registration of the paper

After loading paper in the Standard Paper Feed Tray / Paper Feed Tray 1 / Paper Feed Tray 2, you must register the characteristics of paper. For registration, use "4.1 Standard Feed Tray" / "4.2 Feed Tray 1" / "4.3 Feed Tray 2" of the menu setting according to the location of paper setting.

The details of setting are shown below.

- Paper size
- Paper type
- Double feed check

When loading paper for which printing has been performed onto the back side, envelopes or paper with a dark ground colour, select "OFF."

If these items are not set properly, printing cannot be performed appropriately. [No Paper] error may occur or the printing quality may not be good.

When you change paper of the tray, please be sure to change the setting of the tray with the menu operation.

"Menu 4 Configuration" p.2-18

- 1 Pull out the Paper Feed Tray until it stops.**

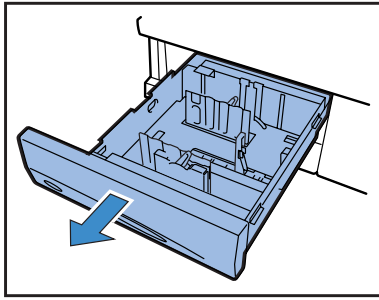

- 2 Turn down the Side Guide Locking Levers to the "FREE" positions and spread the guides to the outermost positions.**

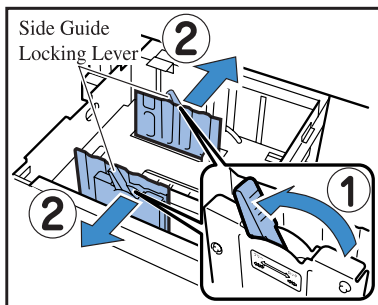

- 3 Adjust the Paper Top Guide to the paper size.**

- First, remove the Paper Top Guide. While pressing the release buttons in the direction shown by the arrow, remove the stopper just above.

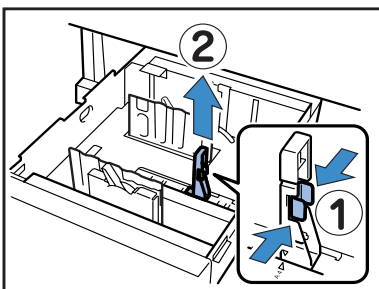

- Then, set the Paper Top Guide. While pressing the release buttons, insert the Paper Top Guide by adjusting the ▼ mark of the Paper Top Guide to the position of the paper size to be set.

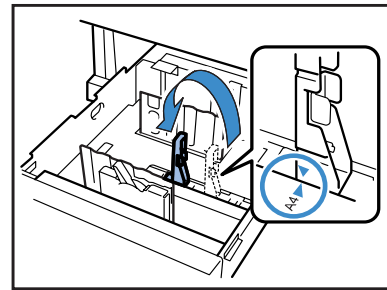

- ▶ When loading A3/Ledger size paper, do not use the Paper Top Guide. Remove the Paper Top Guide and insert it into the holder in the Paper Feed Tray.

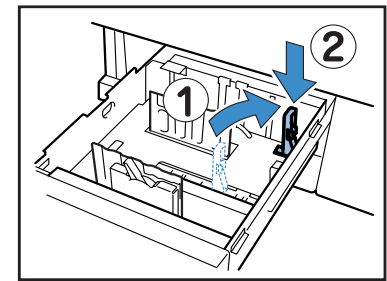

- 4 Load paper by positioning the centre of the paper to the centre mark (▼) inside the Paper Feed Tray.**

If the front side quality is different from the back side quality, load paper with the print face down. Do not exceed the upper limit label.

Take care the paper is not bent at the Paper Top Guide.

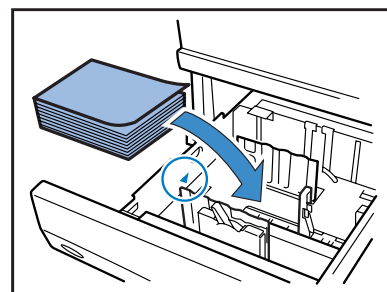

5 Adjust the guides to the paper size.

Slide the guides to adjust to the paper width and turn down the Side Guide Locking Levers to the "LOCK" positions to secure the guides.

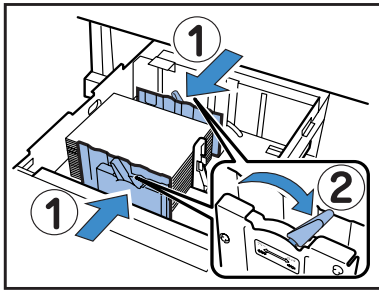

6 In the menu setting, set the size, paper type, and double feed check.

Use "4.2 Feed Tray 1" and "4.3 Feed Tray 2" of Menu 4 for the setting.

"Menu 4 Configuration" p.2-18

When loading paper with a dark ground colour, set "Double Feed Check" to "OFF."

1

Loading Paper (Standard Paper Feed Tray)

1 Open the Standard Paper Feed Tray in the direction shown by the arrow until it stops.

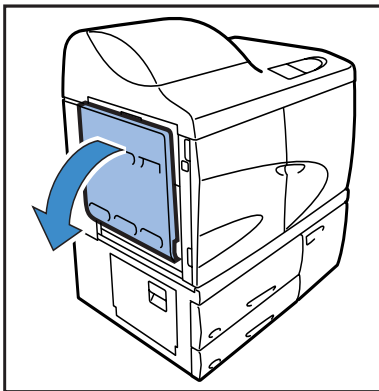

2 Load paper.

Load paper according to the indication of the Standard Paper Feed Tray.

Load the paper with printing side up.

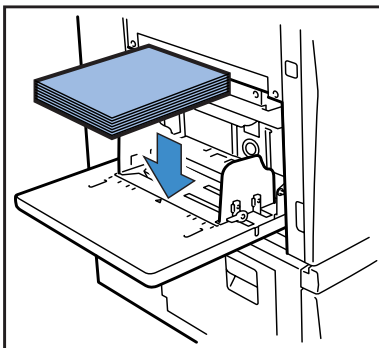

3 Adjust the Feed Tray Paper Guides to the paper size.

Slide the Feed Tray Paper Guides to adjust to the paper width and turn down the Feed Tray Paper Guide Levers to the "LOCK" positions to secure the guides.

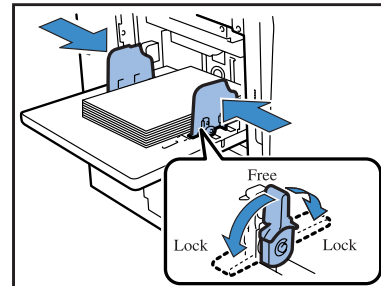

4 In the menu setting, set the size, paper type, and double feed check.

Use "4.1 Standard Feed Tray" of Menu 4 for the setting.

"Menu 4 Configuration" p.2-18

When setting paper for which printing has been performed onto the back side or paper with a dark ground colour, set "Double Feed Check" to "OFF."

Paper Feed Pressure in Standard Paper Feed Tray

In the Standard Paper Feed Tray, the paper feed pressure can be adjusted with the Paper Feed Pressure Adjustment Lever according to the paper that has been loaded. Set the lever to "✳ (NORMAL)" or "✳ (CARD)" according to the paper quality. If "✳ (CARD)" is selected, paper is fed with higher pressure.

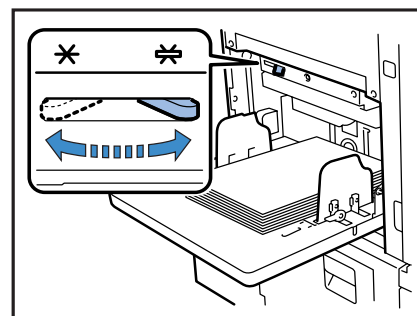

⦿ Paper Feed Pressure Adjustment Lever and Paper

Supported paper qualities are shown below.

Lever position	Paper quality	Supported printing paper
[✳ (NORMAL)]	Standard or Thin/Light	<ul style="list-style-type: none"> • Fine • RISO PAPER IJ • RISO PAPER IJ MATTE • RISO IJ Double-Sided Matte Paper • Commercially available copy paper
[✳ (CARD)]	Card or Special	<ul style="list-style-type: none"> • Drawing paper (*) • Postcard (*) • Envelope (*)

*If paper is not fed properly, set the lever to " ✳(NORMAL)."

When Adding or Replacing Paper in the Standard Feed Tray

When adding paper of the same size or replacing it with paper of a different size, use the Feed Tray Descent button. If all sheets of paper is removed from the Standard Feed Tray, the tray lowers automatically.

1 Press the Feed Tray Descent Button to lower the Standard Feed Tray.

Press and hold down the button until the tray lowers to the desired position.

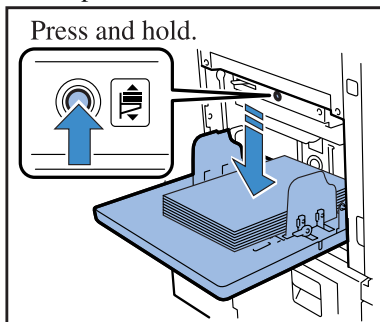

2 Add or replace the paper.

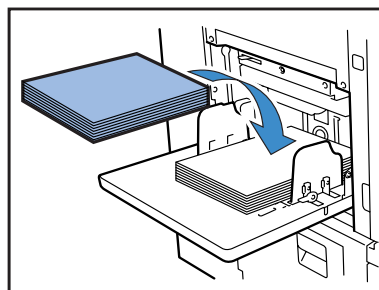

In this unit, paper feed can be performed sequentially from Feed Tray 1, Feed Tray 2, and the Standard Feed Tray for high-volume printing if the same size of paper is loaded in these feed trays. ("Feed Tray Relay" function)

If feed tray relay is set, load paper of the same size, same paper quality, and same paper type in these feed trays.

"4.5 Triple-Tray Source" p.2-22 "4.4 Feed Tray Relay" p.2-21

When you replace paper with different one, change "4.1 Standard Feed Tray" of the menu setting.

How to Close the Standard Feed Tray

With the power on, remove the paper from the Standard Feed Tray, spread the Feed Tray Paper Guides, and close the Standard Feed Tray.

! After checking that the Standard Feed Tray is at the lowermost position, close it.
If you turn off the printer power before removing paper, the Standard Feed Tray does not lower.

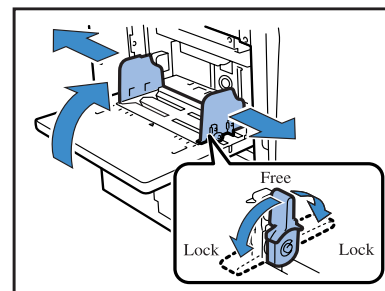

Setting Up the Paper Receiving Tray

Set the Paper Receiving Tray.
(This procedure is not required when a finisher is connected.)

 The Side Guides and the End Guide move automatically to the optimum positions according to the printing paper size. Fine position adjustment can be performed on the Control Panel. For details, refer to "4.8 Paper Ejection" (p.2-25) of the menu setting.

- 1 Open the Paper Receiving Tray in the direction shown by the arrow until it stops.**

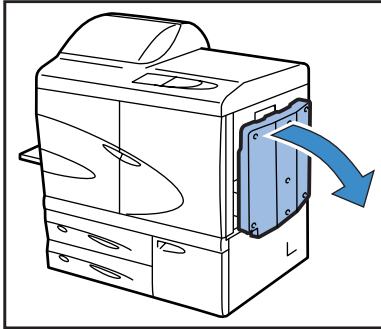

- 2 Raise the Side Guides.**

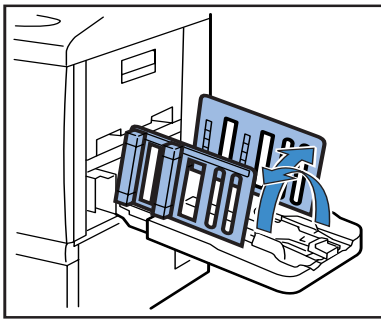

- 3 Adjust the Arrangers.**

Normally, when printing onto B4 or larger paper, take out the Paper Arrangers. Paper arrangement depends on the paper firmness and so on. Adjust the Paper Arrangers as needed.

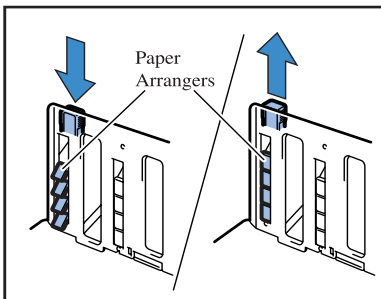

- 4 Raise the End Guide.**

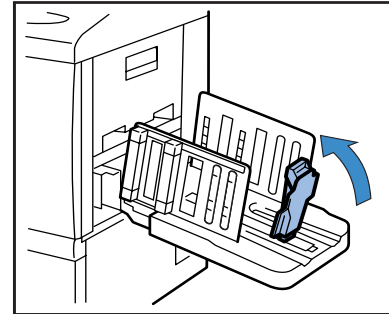

- 5 Adjust the position of the End Guide Cushion.**

Use the Paper Feed Pressure Adjustment Lever to set the cushion to [NORMAL] or [CARD] according to the paper quality.

Do not pull out the Cushion from the Cushion Stand.
"Paper Feed Pressure in Standard Feed Tray" (p.1-14)

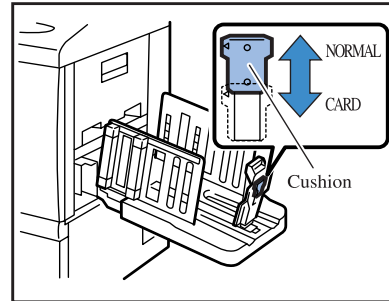

-  When printing onto paper larger than 320 × 432 mm (12⁵/₈" × 17"), fold all the guides.

At this time, set "4.8.2 Stack Guide" (p.2-26) of the menu setting to "OFF."

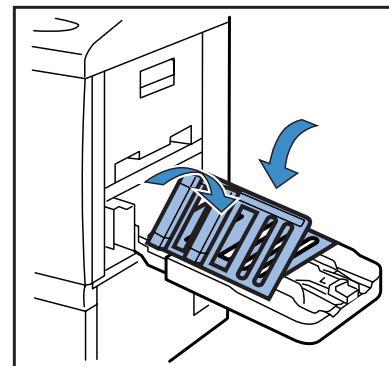

How to Close the Paper Receiving Tray

Close the Paper Receiving Tray as described below.

- 1 Check that no print remains and press the [Stack Guide Open Button].**

The Stack Guide (side) and the Stack Guide (End) move to their storage positions.

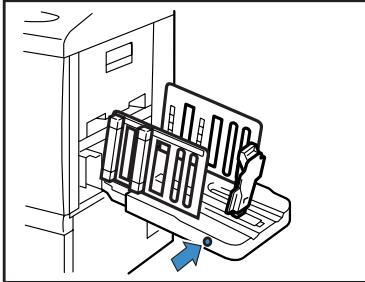

- 2 Fold in the Stack Guide (End) outward.**

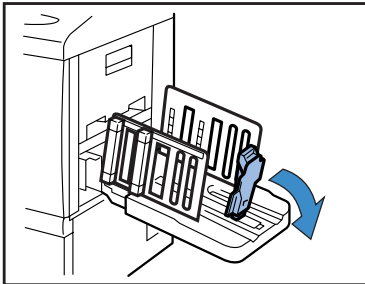

- 3 Pull up the Arrangers.**

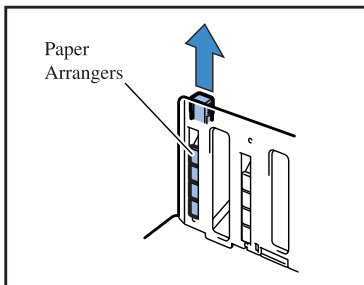

- 4 Fold in the Stack Guide (Side).**

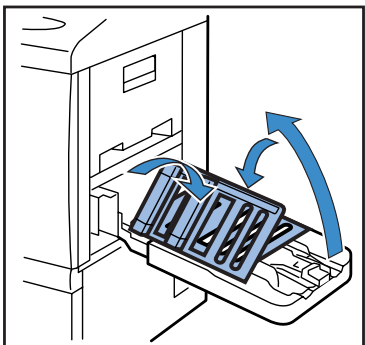

- 5 Close the Paper Receiving Tray.**

Basic Printing Operation

After connection and preparation are complete, perform trial printing. This section describes the basic operation method of “Direct Printing”, namely printing data created in the computer without storing data in the printer.

- ▶ Required software must be installed in the computer in advance.
For details, refer to the separate "HC5500 Series User's Manual for Printer Driver."
- Check that the printer is on and the consumables are set before printing.

Print Operation Flow

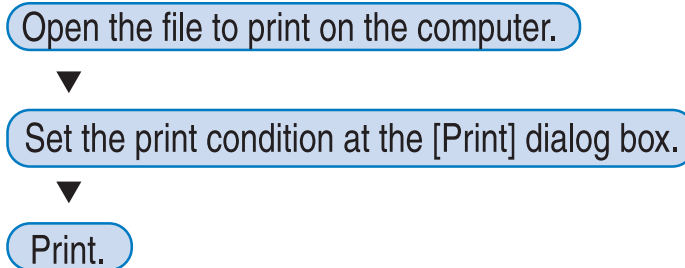

Printing from the Computer (Windows)

This section describes a print instruction using RISO Controller HC3R-5000 from Microsoft Word 2003 as an example.

1 Check that the printer and the computer are turned on.

- ▶ If the printer is in the sleep mode or if the RISO console screen cannot be displayed on the computer, use the RISO Wakeup Tool to start the printer and then carry out steps 2 and after.
For details, refer to separate "HC5500 Series User's Manual for Printer Driver."

2 Open the file to print.

Start the application software to open the original data file to print.

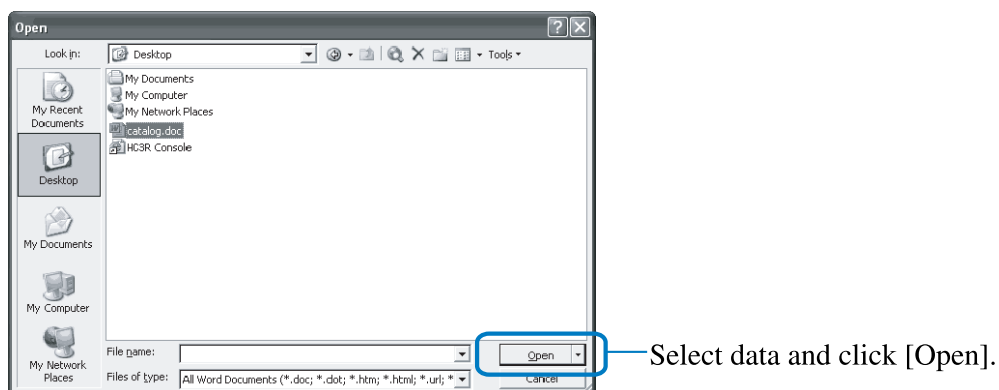

3 Display the [Print] dialog box.

Select [Print] from the [File] menu.

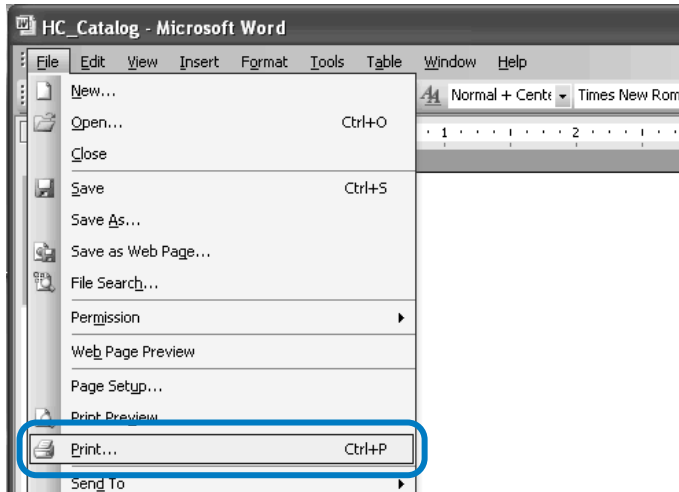

1

4 Check the [Printer name].

As the printer name, select the name set when the printer driver was installed.

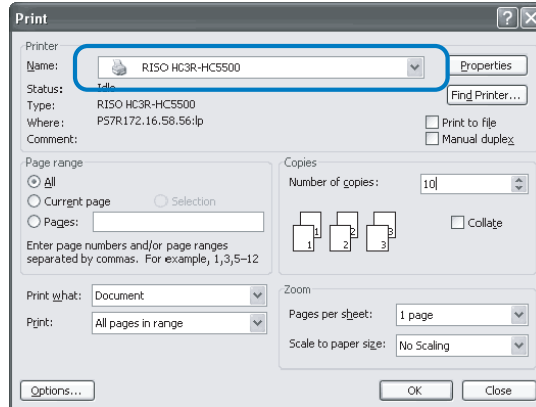

5 Check the following items.

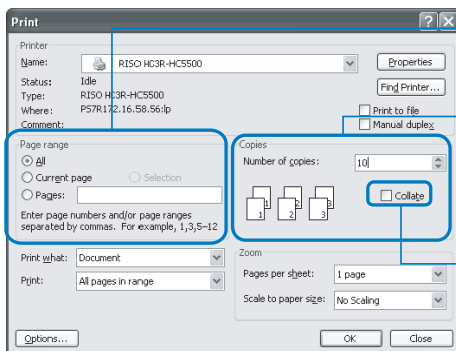

- Print range
Specify the page range of data to be printed.
- Output volume
Specify the output volume for original data with a number.
- ❗ Be sure to clear the checkmark.
Even for collated printing, clear the checkmark at [Collate.]

❗ If you click the [Properties] button, you can set the various conditions on the printer driver screen. The settings of [Original image] on the [Main setting] tab and [Paper type] on the [Main setting] tab affect seriously the print quality. When using conditions other than the default settings, click the [Properties] button and adjust the settings.

"Chapter 2 Printer Driver Operation for HC3R-5000" of "HC5500 Series User's Manual for Printer Driver" p.2-1

"Chapter 3 Printer Driver Operation for PS7R-9000/5000" of "HC5500 Series User's Manual for Printer Driver" p.3-1



Print data can be protected with the security function.

"HC5500 Series User's Manual for Printer Driver" "Chapter 2 Printer Driver Operation for HC3R-5000" p.2-27

"Chapter 3 Printer Driver Operation for PS7R-9000/5000" p.3-27

6 Click the [OK] button.

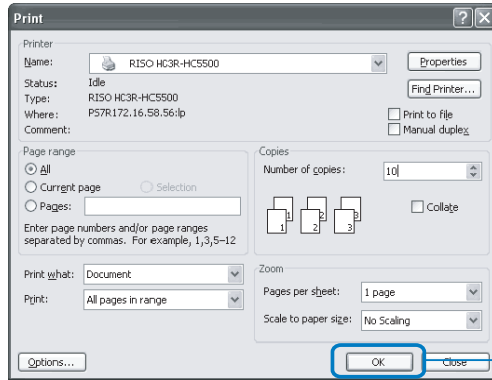

Check the setting and click.

When the printer receives data sent from the computer, the DATA indicator blinks and message "Receiving Data" is displayed on the Display. When reception is complete, the DATA indicator lights up, message "Printing" is displayed, and printing starts. p.2-2



If a message indicating that printing cannot be performed is displayed on the screen, the printer may be in the sleep mode. Press the Sleep Key on the operation panel of the printer or use the Wakeup Tool from the computer to start the printer.

7 Press the Stack Guide Open Button and remove the prints from the Paper Receiving Tray.

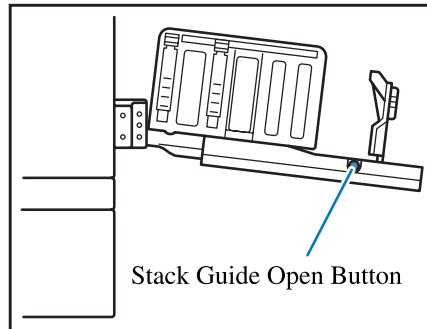

If the button is pressed, the Stack Guides is spread to allow easy removal of prints.



The guides to be spread when the Stack Guide Open Button is pressed can be selected. "4.8.4 Shifting Guide" p.2-27

Printing onto Envelope

You can perform printing onto commercially available envelopes. This section describes notes for printing onto an envelope and the printing procedure.

- ❗ When using envelopes, set "5.1 Paper Size Entry" and "5.2 Paper Type Entry" of the menu setting. At this time, be sure to set the "Paper Type Entry" to "Envelope."
- Be sure to set envelopes in the Standard Feed Tray. Up to 100 envelopes can be set at a time. (The maximum height is 100 mm.) Also follow the orientation of envelopes. If envelopes are set in an incorrect orientation, an envelope may jam in the printer or the print head may be damaged. If the orientation of the data created on the computer is different from the orientation of the envelopes in the tray, set the orientation on the printer driver.
- Set the envelopes in the Standard Feed Tray with the flaps spread. (Do not bend the flaps.)
- Perform the setting as follows:
 - Set the Paper Feed Pressure Adjustment Lever to "CARD."
 - Set "4.1.2 Paper Type" of the menu setting to "Envelope."
- When printing onto envelopes, the following functions cannot be used.
 - Duplex printing
 - Facedown printing set by the printer driver
 - Optional finisher functions

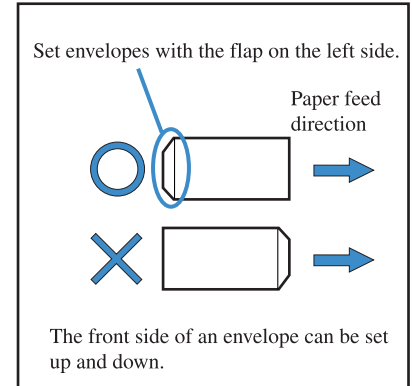

1

📢 When the HC Finisher is connected, the printed envelopes are ejected onto the Top tray only.

Envelope Size and Maximum Print Area (Image Area)

For printing onto envelopes, "Paper Size Entry" is required.

Register the envelope size (length) that includes the flap.

The Maximum Print Area (Image Area) for envelopes is different from the area for normal paper and is the area inside 10 mm ($\frac{3}{8}$ ") from the edges of the registered size. Please refer to p.2-32 5.1 Paper Size Entry

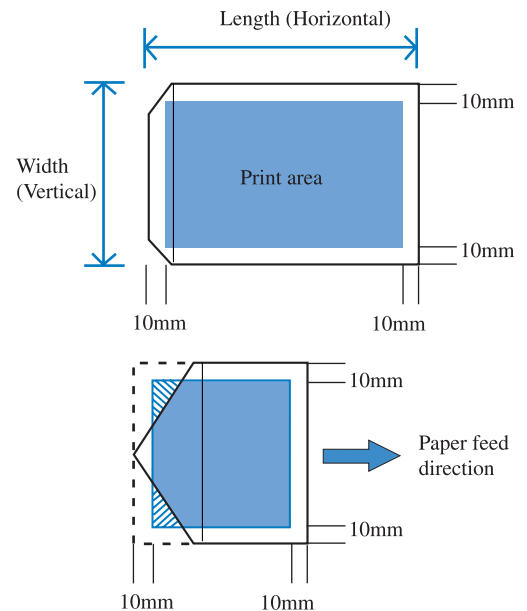

📢 When creating data for printing onto envelopes, take care so that the print area does not protrude from the flap of the envelopes. If original data is printed in the areas indicated with oblique lines, the belt inside the printer becomes dirty, resulting in trouble.

How to Print

- 1 Set "4.1 Standard Feed Tray" of the menu setting.

"4.1 Standard Feed Tray" p.2-19

Paper Size	Registered Paper Size 1 - 5
Paper Type	Envelope
Double Feed Check	OFF

- 2 Lower the Standard Feed Tray to the lowest position and open the paper guides fully.

- 3 Raise the end of the Standard Feed Tray and hang the stopper roller in the main unit side on the hook.

The Standard Feed Tray is fixed in an inclined state.

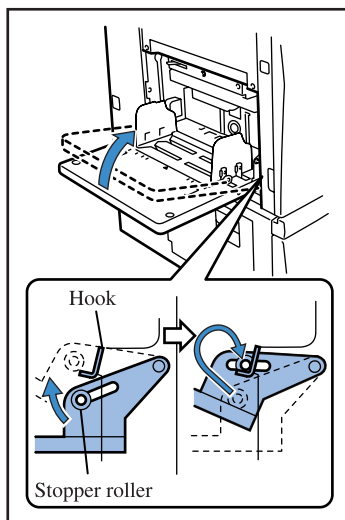

- 4 Set the envelopes in the Standard Feed Tray.

Set the envelopes with the flap on the left side.

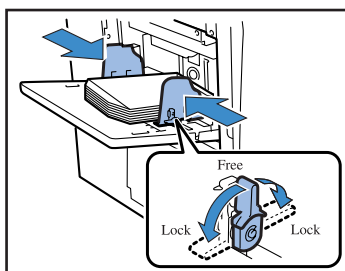

- 5 Adjust the paper guides according to the envelopes and lock them.

- 6 Set the Paper Feed Pressure Adjustment Lever to [(CARD)].

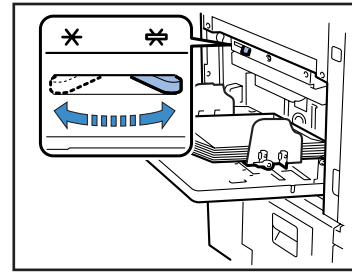

- 7 From the computer, open the file to print.

- 8 Display the [Print] dialog box.

From the [File] menu, select [Print].

- 9 Click the [Properties] button.

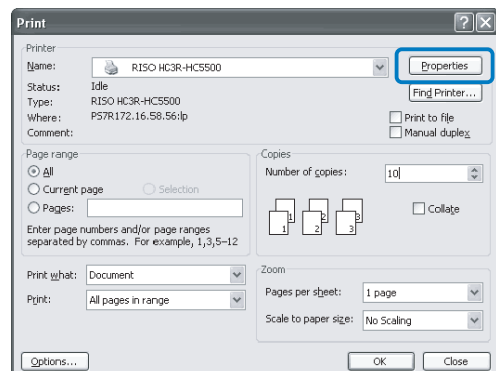

- 10 Select [Envelope] at [Paper Type] on the [Main setting] tab.

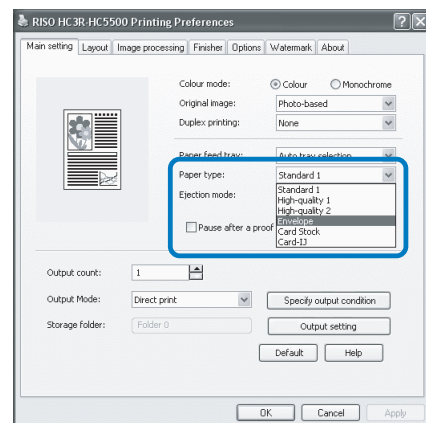

11 Select [Standard Feed Tray] at [Paper feed tray] on the [Main setting] tab.

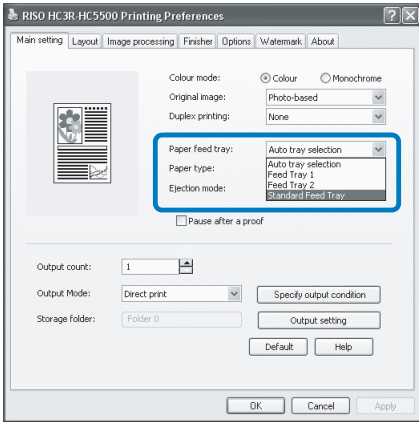

12 Click the [OK] button.

The printer driver screen is closed.

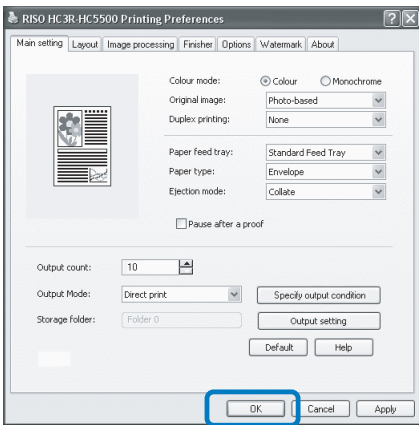

13 Click the [OK] button in the [Print] dialog box.

Printing starts.

If a check mark is placed at [Pause after a proof] in step 10, printing stops temporarily after one copy is printed. Check the print result and then press the PRINT/PAUSE key.



- If the envelopes cannot be fed properly, return the Paper Feed Pressure Adjustment Lever to [NORMAL] and perform printing.
- If double feed or misfeed occurs frequently, adjust the front end of the envelopes (to be fed first) down and set them in the Standard Feed Tray.

When Printing is Complete

Return the Standard Feed Tray to the original position.

- 1 Lower the Standard Feed Tray to the lowest position and open the paper guides fully.**

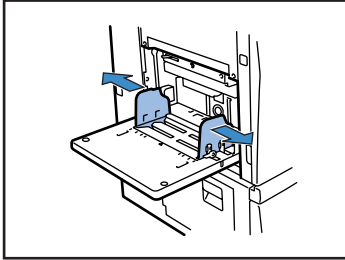

- 2 Raise the Standard Feed Tray so that the angle from the horizontal plane exceeds 45 degrees and release the stopper roller from the hook.**

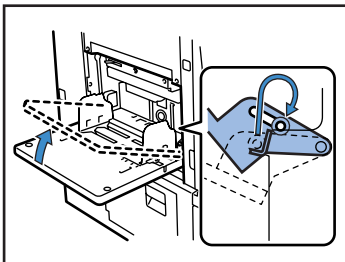

- 3 Gently return the Standard Feed Tray to its original position.**

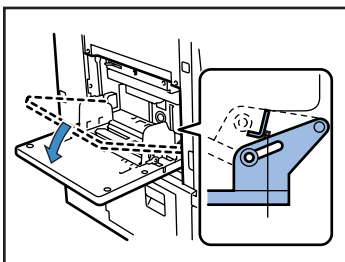

If you set another type of paper in the Standard Feed Tray, change the setting of "4.1 Standard Feed Tray" of the menu setting.

Chapter2 Printer Configuration

This chapter describes the status of the Operation Panel that is displayed during printing. Also this chapter describes the method of setting the printer using the Operation Panel. After sending data to the printer, you can adjust the print position and perform test printing.

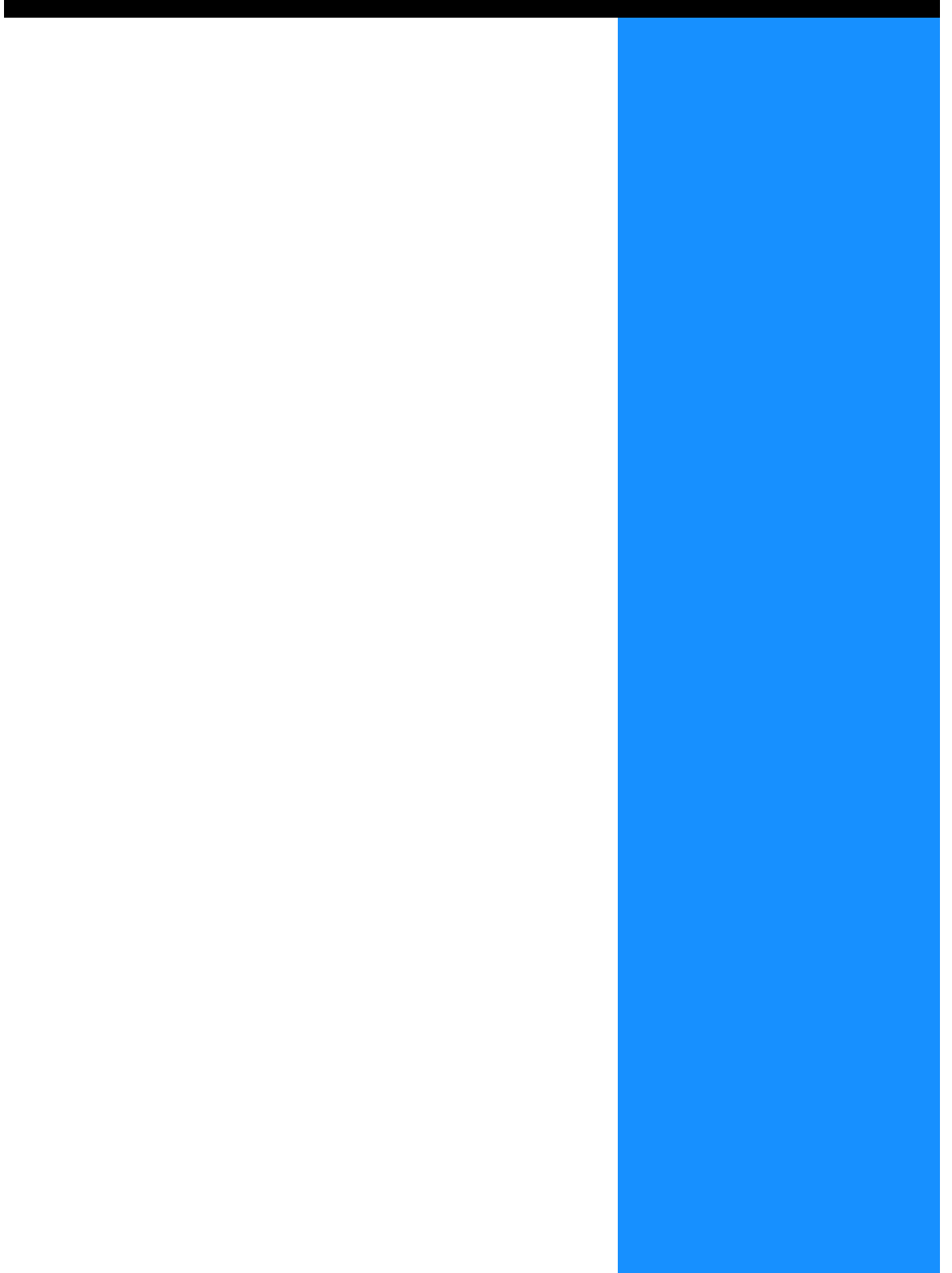

Message Display and Operation Keys

This section describes the meaning of each display in the Message Display and operation keys.

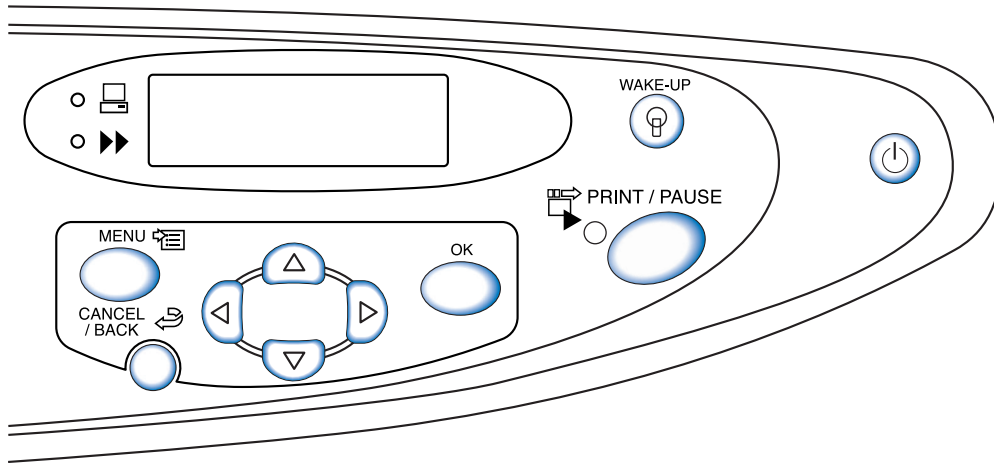

Message Display

In the Message Display, a message indicating printer operation status is displayed. Principal display items and locations are shown below.

During Printing

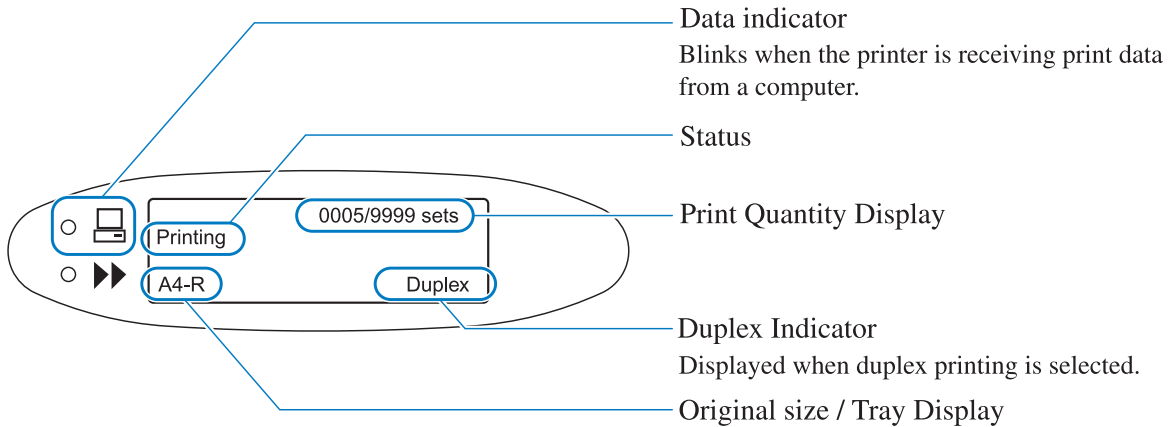

In Menu Setting

When "Ready" is displayed or the PRINT/PAUSE indicator does not light, pressing the MENU Key displays the menu setting screen.

For details, refer to "How to Use the Operation Panel" (p.2-5).

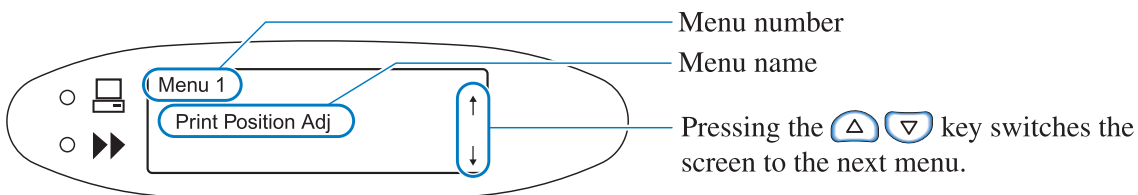

When an Error Occurs

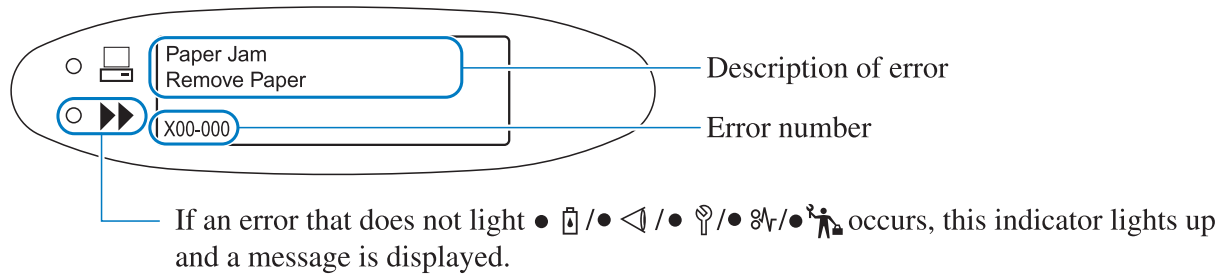

When an error occurs, an error number and its description are displayed in the Message Display. For error numbers, refer to "Chapter 3 Troubleshooting" p.3-1.

⦿ Status

The status of the printer is displayed. The following messages are displayed.

Message	Meaning
Please Wait a Moment	The printer is warming up or is being restored from an error. Printing cannot be performed.
Warming Up	The printer is warming up because the temperature of the print head is low.
Ready	The printer is ready to receive data.
Receiving Data (The Data Indicator blinks.)	The printer is receiving data for printing from a computer.
Printing Mode Off	The printer is waiting for a print instruction from the Operation Panel.
Printing	The printer is printing or processing data.
Cooling Down	The printer is cooling down because the temperature of the print head is high.
Shutting Down	The printer shuts down.

⦿ Print Quantity Display

The number of printed copies and the preset number of copies for printing are displayed.

For collated printing, the preset number of sets and the number of printed sets are displayed. For non collated printing, the preset number of sheets and the number of printed sheets are displayed.

⦿ Duplex Display

This display appears when duplex printing is set.

⦿ Original Size/Tray Display

The selected tray and the size and the orientation of the papers are displayed.

If a feed tray is specified individually, the specified tray is displayed.

If automatic selection of a feed tray is set, "Auto" is displayed, and during printing, the paper size is displayed.

If mixed sizes of originals are set, the largest size is displayed.

Operation Keys

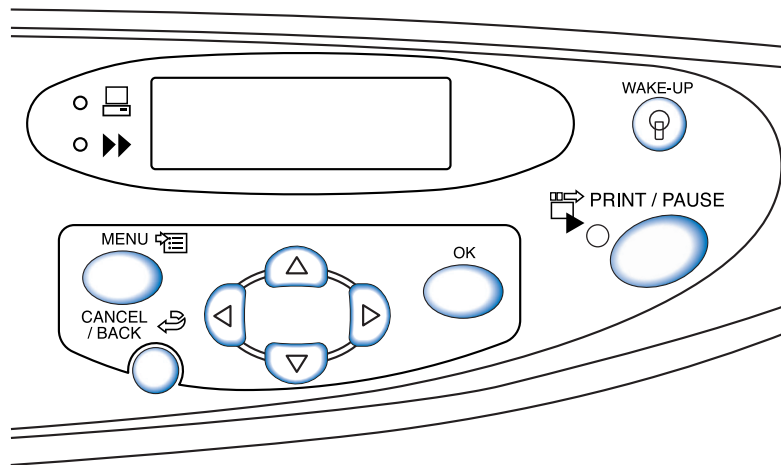

The functions of the keys are shown below. One key may have more than one function.

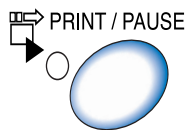

PRINT/PAUSE Key

- Turns on or off the Printing mode.
When the Printing mode is on, the indicator is lit, and when the Printing mode is off, the indicator is not lit.
- If the key is pressed once during printing, printing stops temporarily. While printing stops temporarily, the indicator blinks. If the key is pressed again, printing resumes.
- If proof copy is instructed, after proof copy is printed, the printer stops temporarily and the indicator blinks. After adjustment and setting are performed as needed, when the PRINT/PAUSE key is pressed, printing starts.

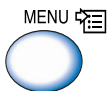



MENU Key

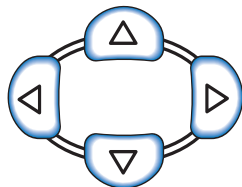

- Press to change the printer initial settings or to exit setting.
- If pressed during menu selection, menu setting is cancelled and the Printing mode is turned off.



Cursor Keys

Use to display the desired menu or change a preset value.

  (Vertical Movement Keys) ... Switch the menu or change the selected value.

  (Horizontal Movement Keys) ... Move to another number on a number entry screen.

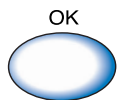

OK Key

Determines the preset content.

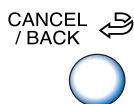

CANCEL/BACK Key

- If pressed during menu selection, the current setting is cancelled and operation returns to one more higher level.
- Press to cancel the function of which the setting is currently performed in a menu.

How to Use the Operation Panel

You can set or change the printer environment such as print position and paper type registration using the MENU Key of the Operation Panel.

Items That Can Be Set from the Menu

The item that can be set from the menu and the details of each setting are shown below.

AAA indicates the factory default setting.

Item	Details of setting (range)	Reference
Menu 1 Print Position Adjust Adjusts the print position.	Horizontal and vertical -20.0mm to +20.0mm ($-1\frac{3}{16}$ " to $+1\frac{3}{16}$ ")	☞ p.2-14
Menu 2 Test Print Prints one sheet for checking the details of setting.	–	☞ p.2-16
Menu 3 Temp Data Retrieve Retrieves temporary data and prints additionally.	0000 1 to 9999	☞ p.2-17
Menu 4 Configuration Sets the paper to be set in the feed trays, the print density, and the Paper Receiving Tray.		☞ p.2-18
4.1 Standard Feed Tray Sets the paper to be loaded in the Standard Feed Tray.		☞ p.2-19
4.1.1 Paper Size	Auto A3/A4/B4/B5/A4-R/B5-R/Foolscap(Ledger/Legal/Letter/Letter-R/Statement)/000 × 000 mm	
4.1.2 Paper Type	Standard Paper 1/High-Quality 1/High-Quality 2/ Paper Type 1 - 5/Envelope/Card/Card-IJ	
4.1.3. Double Feed Check	ON OFF	
4.2 Feed Tray 1 Sets the paper to be loaded in Feed Tray 1.		
4.2.1. Paper Size	Auto A3/A4/B4/B5/A4-R/B5-R/Foolscap(Ledger/Legal/Letter/Letter-R/Statement)/000 × 000 mm	
4.2.2 Paper Type	Standard Paper 1/High-Quality 1/High-Quality 2/ Paper Type 1 - 5	
4.2.3 Double Feed Check	ON OFF	
4.3 Feed Tray 2 Sets the paper to be loaded in Feed Tray 2.		
4.3.1 Paper Size	Auto A3/A4/B4/B5/A4-R/B5-R/Foolscap(Ledger/Legal/Letter/Letter-R/Statement)/000 × 000 mm	
4.3.2 Paper Type	Standard Paper 1/High-Quality 1/High-Quality 2/ Paper Type 1 - 5	
4.3.3 Double Feed Check	ON OFF	

Item	Details of setting (range)	Reference
4.4 Feed Tray Relay Sets whether or not to feed paper continuously by changing automatically the feed trays.	ON OFF	☞ p.2-21
4.5 Triple-Tray Source Sets whether or not the Standard Feed Tray is selected in automatic tray selection.	ON OFF	☞ p.2-22
4.6 Job Separation Selects whether or not to perform Job Separation in printing and selects the type of this function.	OFF Between Jobs Every Division (If this function is set with the printer driver, the value is displayed.)	☞ p.2-23
4.7 Print Density Adjusts the density of overall prints.	Density-Level 1/2/3/4/5 (If the density is set with the printer driver, the value is displayed.)	☞ p.2-24
4.8 Paper Ejection Sets the Paper Receiving Tray.		☞ p.2-25
4.8.1 Eject Wing Sets the shape of the Eject Wing Adjust.	Auto Special	
4.8.2 Stack Guide Adjusts the Stack Guide position.	Auto Adjusted Position OFF	
4.8.3 Stack Guide Adjust Sets the Adjusted Position in 4.8.2.	Side Guides: -20mm to +20 mm (- ¹³ / ₁₆ " to + ¹³ / ₁₆ ") End Guide: -20mm to +20 mm (- ¹³ / ₁₆ " to + ¹³ / ₁₆ ")	
4.8.4 Shifting Guide Sets the Stack Guides move position when the Stack Guide OpenButton is pressed.	End Guide Side Guides End & Side Guides	
4.9 Temp Data Clear Clears temporary data.	-	☞ p.2-28
4.10 Image Area Sets the maximum print area.	Standard Maximum	☞ p.2-29
4.11 Cover Sheet Tray Sets the paper to be loaded in the Cover Sheet Tray of the optional HC Finisher.		☞ p.2-30
4.11.1 Paper Size	Auto A3/A4/B4/B5/A4-R/B5-R/Ledger/Legal/Letter/Letter-R	
Menu 5 Administration Sets the basic information of the printer.		☞ p.2-31
5.1 Paper Size Entry Registers non-standard paper sizes. Up to five sizes can be registered. (5.1.1 - 5.1.5)	000 × 000mm 90mm - 340mm × 148mm - 550mm (3 ⁹ / ₁₆ " - 13 ³ / ₈ " × 5 ¹³ / ₁₆ " - 21 ⁵ / ₈ ")	☞ p.2-32
5.2. Paper Type Entry Registers paper types. Up to five types can be registered.(5.2.1 - 5.2.5) In addition, registers paper feed control of certain paper.(5.2.6 - 5.2.12)		☞ p.2-33

Item	Details of setting (range)	Reference
5.2.1 - 5 Registration (5.2.1.1 - 5.2.5.1)	ON OFF	☞ p.2-33
5.2.1 - 5 Paper Type (5.2.1.2 - 5.2.5.2) This setting determines the colour tone adjustment.	Standard Paper 1/High-Quality 1/High-Quality 2/ Envelope/Card/Card-IJ	
5.2.1 - 5 Paper Feed Control (5.2.1.3 - 5.2.5.3) (5.2.6.1 - 5.2.12.1) This setting determines the paper feed pressure etc..	Standard/Card/ Thin/Light/Custom/Envelope	
5.3 Separation Paper Sets the feed tray for job separation paper.	OFF Standard Feed Tray Feed Tray 1 Feed Tray 2	☞ p.2-36
5.4 Count Management Displays the number of printed sheets.		☞ p.2-37
5.4.1 Copy Count Displays the total number of printed pages.	-	
5.4.3 Count Pattern Displays the count for each combination of conditions such as size and type.	-	
5.5 Head Maintenance Performs cleaning of the print head.		☞ p.2-40
5.5.4 Hyper-Cleaning Performs powerful cleaning for each head.	K/C/M/Y	
5.5.5 Normal Cleaning Performs cleaning of all heads together.	-	
5.5.6 Cleaning Cycle Sets the cycle of automatic normal cleaning.	500 100 - 3000 (in 100 increments)	
5.6 Configuration Information Print Prints the information of the printer such as detailed settings in a list.		☞ p.2-42
5.6.1 System Information Displays the information such as printer memory capacity, firmware version, and IP address in a list for checking.	-	
5.6.2 Menu Setting Displays the menu settings established from the operation panel in a list for checking.	-	
5.6.4 Count Pattern Prints the result of "5.4.3 Count Pattern" and the count of the HC Finisher function (only if an optional finisher is connected) in a list.	-	

Item	Details of setting (range)	Reference
5.7 Network Configuration Sets the information concerning the network such as IP address.		☞ p.2-45
5.8 Initial Setting		☞ p.2-46
5.8.1 Sleep Sets whether or not the printer enters the sleep mode to reduce power consumption when the printer is not used for a certain time.	ON OFF	
5.8.2 Waiting Time Sets the time that elapses until the printer enters the sleep mode when "5.6.1 Sleep" is set.	60 min. 1 - 99 min.	
5.8.3 Beep Sound -Key Sets whether or not a beep sounds when a key is pressed.	ON OFF	
5.8.4 Beep Sound -Status Sets whether or not a beep sounds when an event such as data reception and end of printing occurs.	ON OFF	
5.8.5 Beep Sound -Error Sets whether or not a beep sounds when an error occurs.	ON OFF	
5.8.7 Displayed Language * Sets the language to be displayed in the Operation Panel.	Japanese/ UK English /US English/French/German/Italian/Spanish/Portugese	
5.8.8 Metric/Inch Switch Sets the unit of length and the paper size type displayed on the Operation Panel. This setting will be reflected when the power is turned off and then on again.	mm inch	
5.8.17 Tray Selection Rule Sets the condition for selecting a tray using the auto tray selection function.	Size Size & Type	
5.8.18 Print Mode Auto-ON Sets whether or not the print mode is automatically turned on when the printer is not used for a certain time with the print mode OFF.	ON OFF	
5.8.19 Print Auto-ON Time Sets the time that elapses until the print mode is turned on when "Print Mode Auto-ON" is set to "ON."	05 min. 1 - 60 min.	
5.8.20 Menu Auto-Shut OFF Sets whether or not the print mode is automatically turned off when no operation is made for a certain time on the menu setting screen.	ON OFF	

Item	Details of setting (range)	Reference
5.8.21 Menu Shut OFF Time Sets the time that elapses until the print mode is turned off when "Menu Auto-Shut OFF" is set to "ON."	05 min. 1 - 60 min.	☞ p.2-46
5.8.22 Stand-by Sets whether or not the printer enters the stand-by mode to reduce power consumption when the printer is not used for a certain time.	ON OFF	
5.8.23 Stand-by Period Sets the time that elapses until the printer enters the stand-by mode when "Stand-by" is set to "ON."	05 min. 1 - 99 min.	
5.8.50 Head Recovery Performs powerful cleaning of the print head nozzles to restore them to the initial state after the printer is not used for a long time.	-	
Menu 6 Feed Tray Selection Selects the feed tray for printing in which required paper is set among multiple feed trays.	Auto Standard Feed Tray Feed Tray 1 Feed Tray 2	☞ p.2-54
Menu 7 Job Clear	-	☞ p.2-55

* If US English is selected, inch system units and paper sizes will be displayed.

Basic Operation of Menu Selection

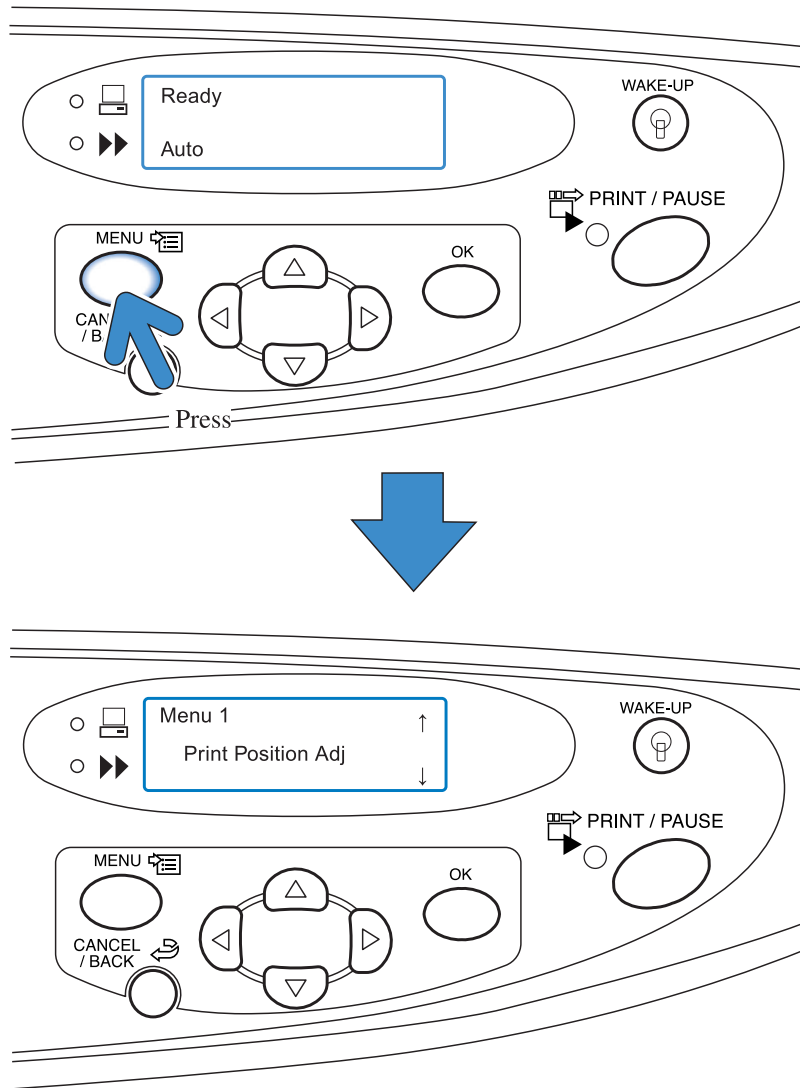

How to Enter the Menu

Set the menu when the printer is not operating, for example, when printing is suspended or the printer is waiting for data. To perform setting when the printer is printing, press the PRINT/PAUSE key to suspend printing (turn off the Printing mode) and press the MENU Key.



When pressing the MENU Key, Menu 1 screen will appear on the Message Display.

Menu Selection

The menu has a tree-type hierarchical structure.
Press the  or  key to display the desired menu.

● Submenu

Menu4 “The Configuration” and Menu5 “Administration” include submenus.

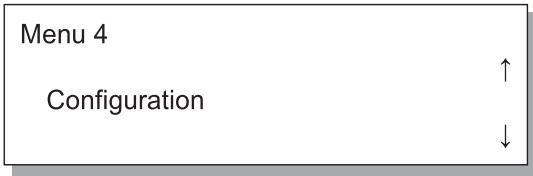

Press the OK Key.

If you press the OK Key when a menu is displayed, its submenu will be displayed.

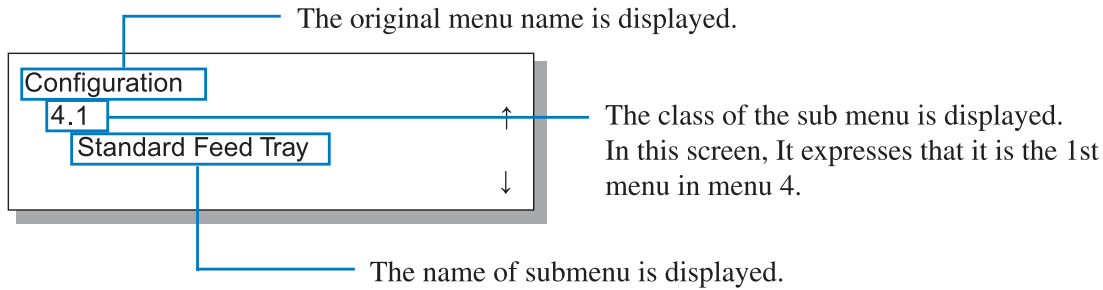

In some menus, the submenu has multiple levels.

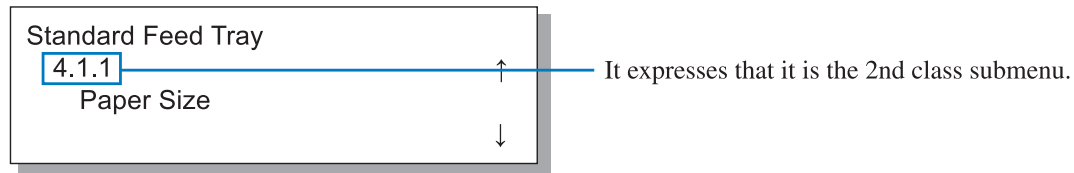

A * mark is displayed at the currently set items or values.

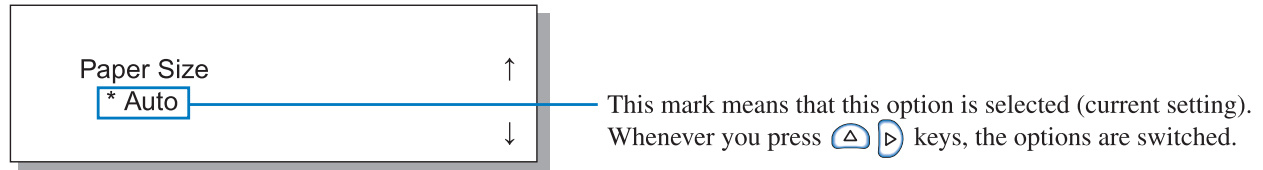

To display "4.1.1 Paper Size", operate as follows.

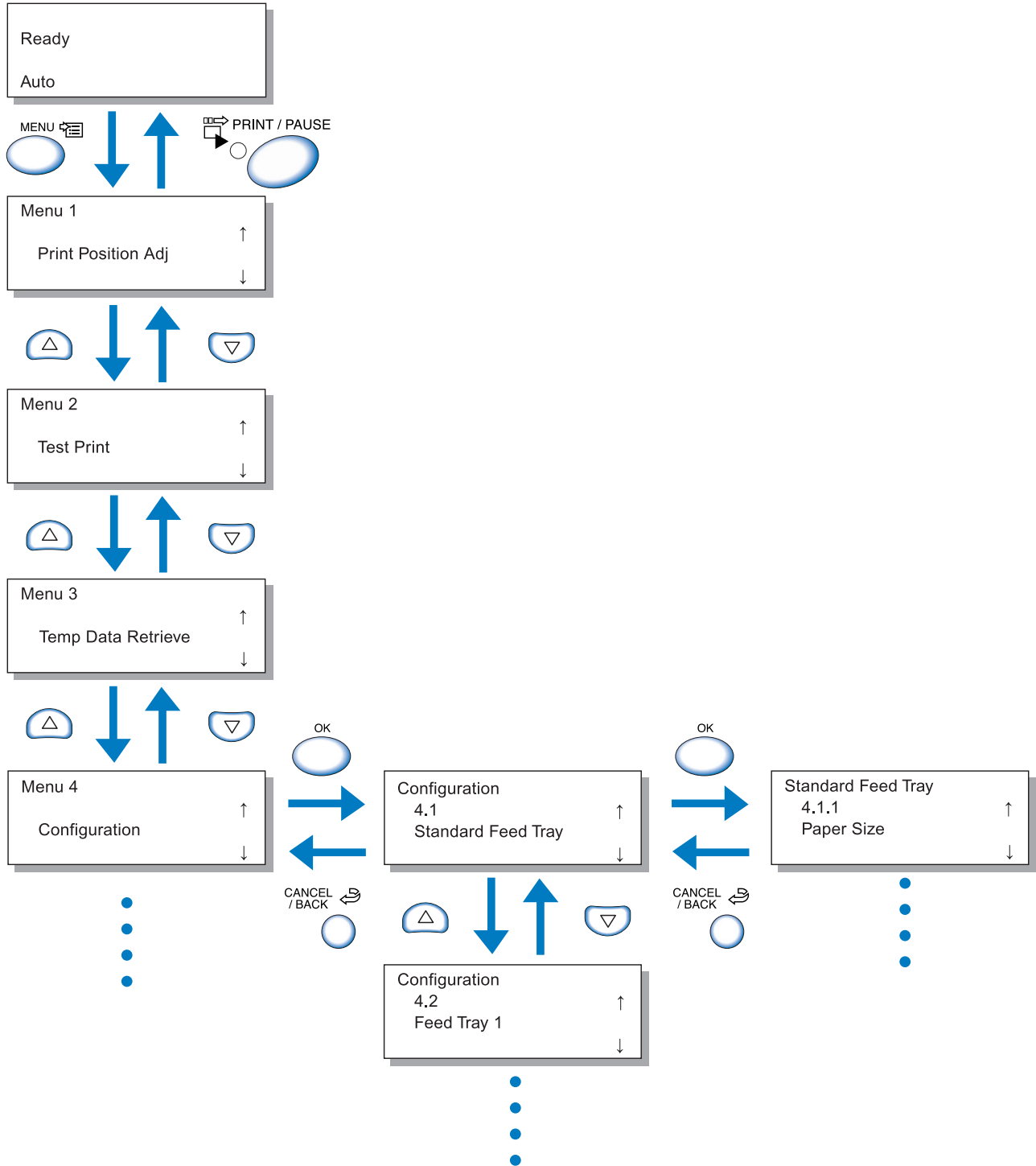

 The menu hierarchy is listed at the end of this manual. Refer also to the list.

Menu Setting

Select the desired menu and press the OK Key.

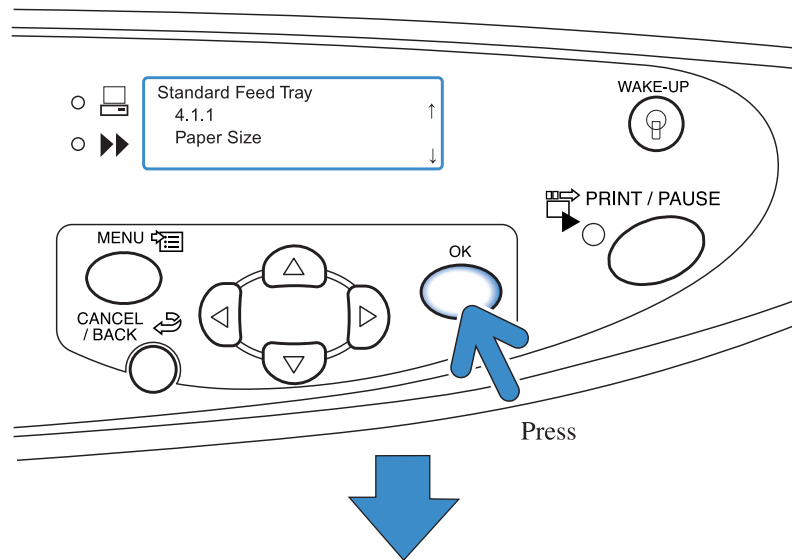

Menu setting can be performed. Press the  or  key to select the desired item and press the OK Key.

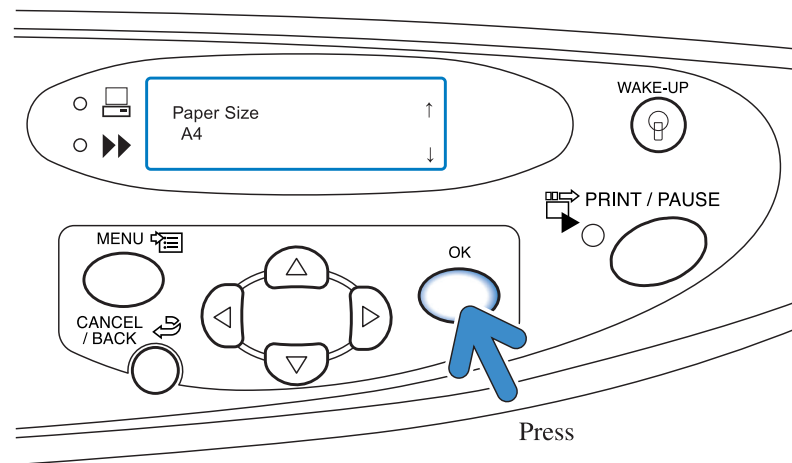

Suspending the Operation

To return to the upper level from a submenu, press the CANCEL/ BACK Key.
To cancel and exit the setting, press the MENU Key.

Exiting the Menu Setting / Starting Printing

After menu setting is complete, press the PRINT/ PAUSE Key to turn on the Printing mode.

Menu 1 Print Position Adjust

Adjusts the print position.

Also the positions can be adjusted for punching and stapling after printing.

Adjustable Range

If you want to shift the print position after checking the printed sheet, use the Cursor Keys on the printer to shift the position.

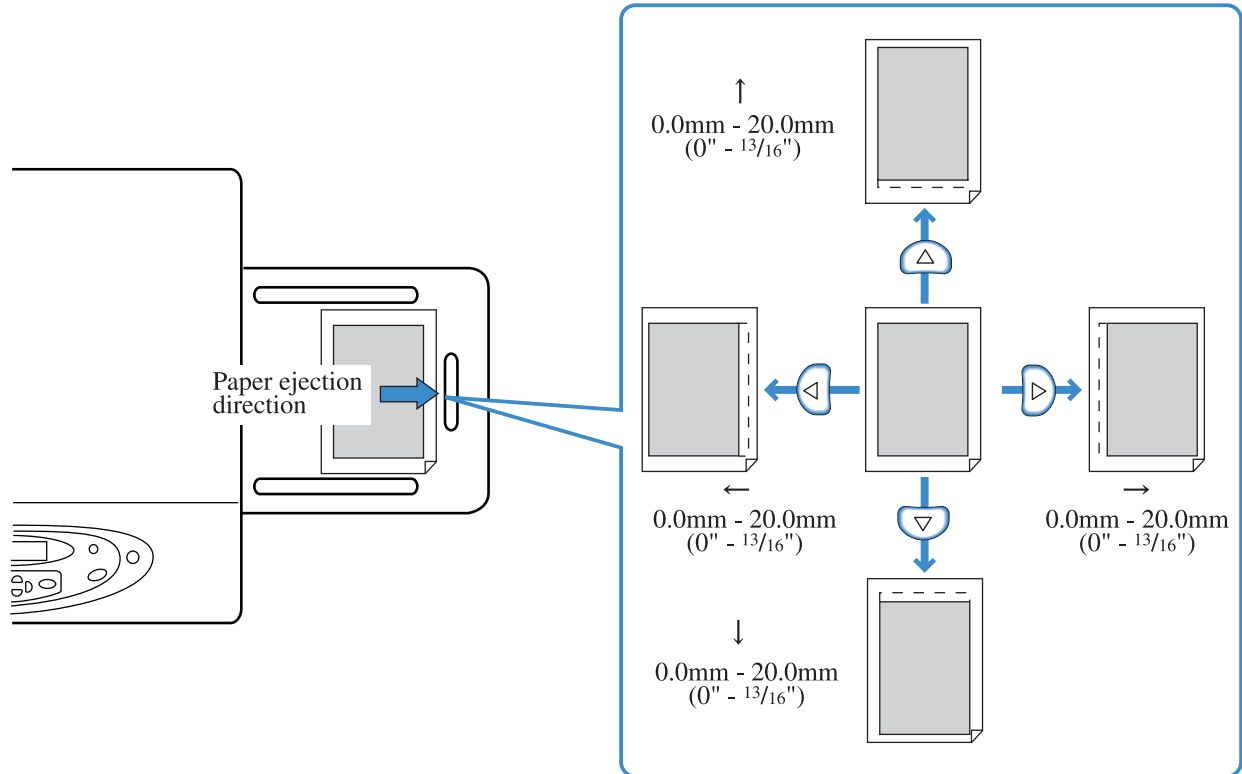

- With reference to the current print position, you can shift the position between 0mm and 20 mm (0" and 13/16") in the vertical (up and down) and horizontal (to the right and the left) directions.
 - You can adjust the position in 0.5 mm (0.02") increments.
- ▶
- If "4.9 Temp Data Clear" of the menu setting has been executed or if setting of no temporary data has been selected (5.8.6 Temporary Data Retention), message "No Temp Data" is displayed.
 - In duplex printing, the print position moves to the same adjusted position on both the front and back sides. This function is useful for making margins for binding.
 - The setting is effective in additional printing performed with "Menu 3 Temp Data Retrieve."

1 Press the MENU Key.

2 Check that "Print Position Adj" is displayed.

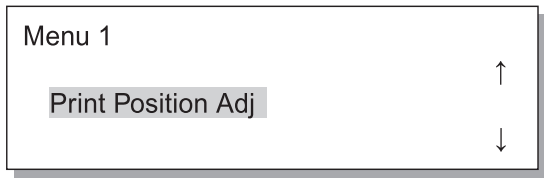

3 Press the OK Key.

4 Press the     keys to adjust the print position.

Only the arrow that corresponds to the pressed key is displayed and the relevant value changes.

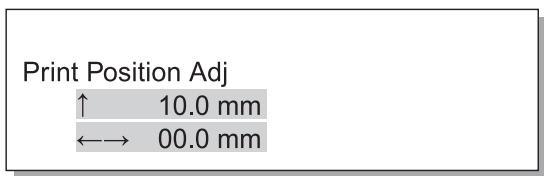

5 Press the OK Key.

The screen returns to the display of Step 2.

6 Press the  key to display "Test Print".



7 Press the OK Key twice.

A single proof copy is printed. Check the print position. To exit the setting, press the PRINT/PAUSE key.

Menu 2 Test Print

Prints the data currently retained in the printer for checking.

Use this function to check to see if the settings such as print position and density adjustments are reflected properly.



- The number of printed sheets with the Test Print function is not counted as the "Number of Copies" that is set on a computer.
- If "4.9 Temp Data Clear" of the menu setting has been executed, message "No Temp Data" is displayed and Test Print cannot be performed.
- If an optional finisher is connected, test print paper is output to the Top Tray regardless of the settings of finisher functions.

1 Press the MENU Key.

2 Press the  key to display "Test Print."

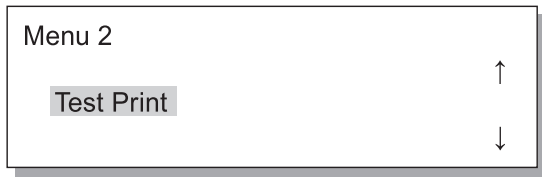

3 Press the OK Key.

4 Check the message and press the OK Key to print.

One sheet is printed. If the CANCEL/BACK key is pressed, the screen in step 2 reappears.

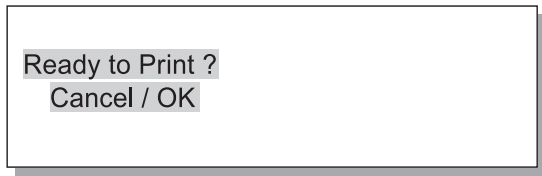

After Test Print is complete, you can continue setting. To exit the setting, press the PRINT/PAUSE key.

Menu 3 Temp Data Retrieve

The data currently retained in the printer can be retrieved and printed again by specifying the number of copies (additional printing).

 Retained data can be retrieved if a check mark is placed at [Keep the last page of the job in the printer.] in [Controller setting 2] - [Initial setting] of [Administrator] of RISO Console. For details, refer to "HC-5500 Series User's Manual for Console."



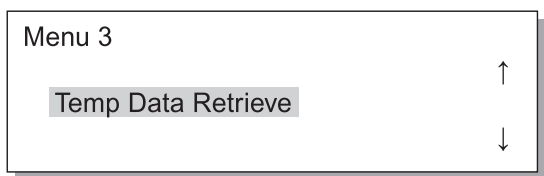

-  The retained data is the last page of the latest printing. In the case of duplex printing, the data of the last sheet (two pages) is retained.
- When the printer enters the sleep mode, retained data will be cleared (not retained).
- The maximum number of copies that can be set for additional printing is "9999."
- If "4.9 Temp Data Clear" of the menu setting has been performed, message "No Temp Data" is displayed.

1 Press the MENU Key.

2 Press the  or  key to display "Temp Data Retrieve."



3 Press the OK Key.

4 Press the   keys to move the cursor, and press the   keys to input the number of copies for printing.

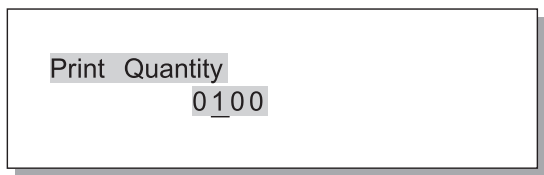

5 Press the OK Key.

6 Press the PRINT/ PAUSE Key.

Printing of the set number of copies starts.

Menu 4 Configuration

Functions concerning printing such as size and type of paper to be loaded in the feed trays and the Job Separation function can be set.

⦿ Functions

The functions that can be set are shown below.

● 4.1 Standard Feed Tray

4.2 Feed Tray 1

4.3 Feed Tray 2

☞ p.2-19

Set the size and type of paper to be loaded in the Standard Feed Tray and the other feed trays and turn on or off the Double Feed Check function.

● 4.4 Feed Tray Relay ☞ p.2-21

Sets whether or not to enable the Feed Tray Relay function that uses Feed Tray 1 and Feed Tray 2. If "4.5 Triple-Tray Source" is set to "ON," feed trays including the Standard Feed Tray can be used for Feed Tray Relay.

● 4.5 Triple-Tray Source ☞ p.2-22

Sets whether or not to include the Standard Feed Tray into feed trays for selection when instructing printing without specifying the tray (Auto tray selection) from the printer driver.

● 4.6 Job Separation ☞ p.2-23

Inserts separation paper between jobs or every division such as set or page when printing multiple sets.

● 4.7 Print Density ☞ p.2-24

Selects the print density from five levels.

● 4.8 Paper Ejection ☞ p.2-25

Sets the adjustment of the Auto Stacking Tray and Eject Wing.

● 4.9 Temp Data Clear ☞ p.2-28

Clears temporary data in the printer.

● 4.10 Image Area ☞ p.2-29

Sets the maximum print area.

● 4.11 Cover Sheet Tray ☞ p.2-30

Sets the paper to be loaded in the Cover Sheet Tray of the optional HC Finisher.

4.1 Standard Feed Tray/ 4.2 Feed Tray 1/ 4.3 Feed Tray 2

Set the size and type of paper to be loaded in the Standard Paper Feed Tray and the other Paper Feed Trays and turn on or off the Double Feed Check function.

Be sure to set when you have changed the type or size of paper.

Settings

Menu (Item)		Selection	
4.1	Standard Feed Tray	4.1.1 Paper Size	Auto/A3/B4/A4/B5/A4-R/B5-R/ Foolscap/ (Ledger/Legal/Letter/Letter-R/Statement) Registered paper size *1 000x000mm
		4.1.2 Paper Type	Standard paper 1/High-Quality 1/High-Quality 2/ Registered paper type*2 1-5/Card/Card-IJ
		4.1.3 Double Feed Check	OFF/ON Selects the detecting of "double feed"(feeding of multiple sheets of paper at a time). Select OFF, when paper described below is used. -Paper printed on one side already -Dark-coloured paper -envelopes
4.2	Feed Tray 1	4.2.1 Paper Size	Auto/A3/B4/A4/B5/A4-R/B5-R/ Foolscap (Ledger/Legal/Letter/Letter-R/Statement) Registered paper size 1-5*1
		4.2.2 Paper Type	Standard paper 1/High-Quality 1/High-Quality 2 Registered paper type*2 1-5
		4.2.3 Double Feed Check	Same as 4.1.3
4.3	Feed Tray 2	4.3.1 Paper Size	Same as 4.2.1
		4.3.2 Paper Type	Same as 4.2.2
		4.3.3 Double Feed Check	Same as 4.2.3



*1 Sizes that have been registered in "5.1 Paper Size Entry" are displayed.

*2 Types that have been registered in "5.2 Paper Type Entry" are displayed.

! "Paper Type" setting determines the colour tone adjustment. If what is selected at [Paper Type] differs from what is loaded really, print quality is not best. Be sure to select the same paper type with what is loaded actually.

An example of method of setting the Standard Feed Tray is used for explanation in the procedure below. For Feed Tray 1 or Feed Tray 2, display "Feed Tray 1" or "Feed Tray 2" in step 4.

1 Press the MENU Key.

2 Press the  or  key to display "Configuration."

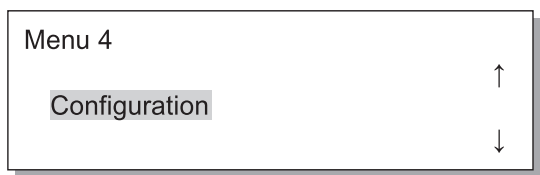

3 Press the OK Key.

4 Press the  or  key to display "Standard Feed Tray."

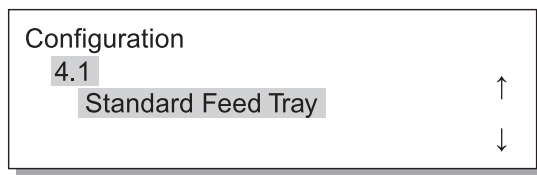

5 Press the OK Key.

The submenu for the Standard Feed Tray (Feed tray) is displayed.

4.1.1/4.2.1/4.3.1 Paper Size

- To use non-standard size paper, register the size to be used in "5.1 Paper Size Entry" of the menu setting in advance. After the size is registered, paper of the size can be used.
- If you use non-standard size paper without paper size entry, a paper jam may occur.
- Paper sizes that can be set are different between the Standard Feed Tray and the other feed trays (1 and 2). ☞ p.2-19
- When setting for Feed Tray 1 /Feed Tray 2, if a registered size is not adequate for the feed tray, the registered paper will not be displayed.
- If an optional HC Finisher is connected, some paper sizes cannot be used. Paper sizes that cannot be used are not displayed in this menu.

1 Check that "Paper Size" is displayed.

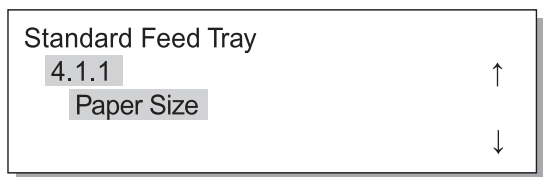

2 Press the OK Key.

3 Press the or key to select the desired size.



4 Press the OK Key.

When the screen in step 1 reappears, you can continue setting.
To exit the setting, press the PRINT/PAUSE key.

4.1.2/4.2.2/4.3.2 Paper Type

- Paper types that can be set are different between the Standard Feed Tray and the other feed trays. ☞ p.2-19
- When the registered paper is used in the Standard Feed Tray, adjust also the Paper Feed Pressure Adjustment Lever according to the paper thickness.

1 Press the or key to display "Paper Type."

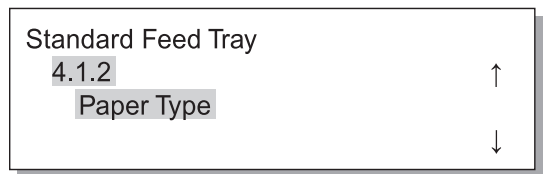

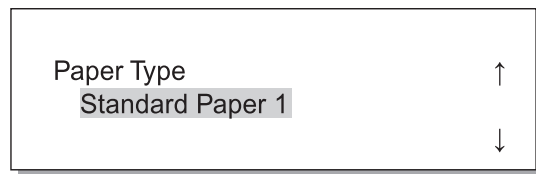

2 Press the OK Key.

3 Press the or key to select the desired paper type.





4 Press the OK Key.

When the screen in step 1 reappears, you can continue setting.
To exit the setting, press the PRINT/PAUSE key.

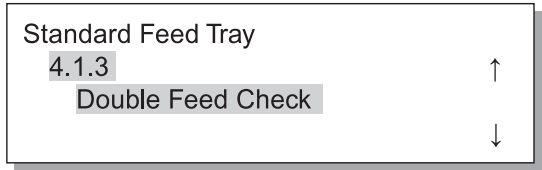
1 Press the  or  key to display "Double Feed Check."



2 Press the OK Key.

3 Press the  or  key to select ON or OFF.

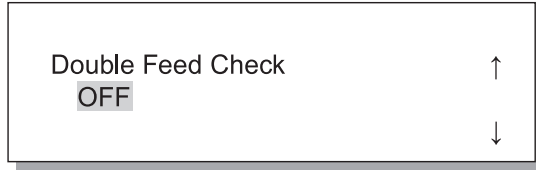

4 Press the OK Key.

When the screen in step 1 reappears, you can continue setting.
To exit the setting, press the PRINT/PAUSE key.

4.4 Feed Tray Relay

"Feed Tray Relay" is the function that when paper in a tray is running out, paper in another tray can be printed continuously. Up to 2,500 sheets of paper can be printed continuously, using the three trays.

-  • Be sure to set the same sized-paper and set them as the same orientation .
- When using paper of the same size and type, set "5.8.17 Tray Selection Rule" to "Size & Type."

Useful Feature

The Feed Tray Relay function is useful in the following cases.

- Paper of the same size and type is always used. (*)
- More than 1,000 sheets of printing is performed at a time.

Mechanism of Feed Tray Relay

If you set Feed Tray Relay, when Feed Tray 2 becomes empty of paper, Feed Tray 1 will be automatically selected and printing will continue. In addition, if "4.5 Triple-Tray Source" is set to ON, the Standard Feed Tray can also be selected for paper feed with this function. The order of priority of tray selection is Standard Feed Tray→Feed Tray 2 →Feed Tray 1.



"4.5 Triple-Tray Source" p.2-22

Settings

OFF	Feed Tray Relay is disabled.
ON	Feed Tray Relay is enabled.



 The feed tray set for separation paper (5.3 Separation Paper) is not selected as a feed tray for Feed Tray Relay or Auto Tray Selection in "Menu 6 Feed Tray Selection." p.2-54.

1 Press the MENU Key.

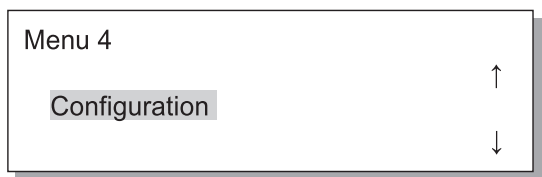
2 Press the  or  key to display "Configuration."



3 Press the OK Key.

4 Press the  or  key to display "Feed Tray Relay."

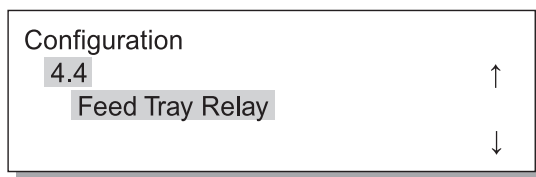

5 Press the OK Key.

The submenu of Feed Tray Relay is displayed.

6 Press the or key to select ON or OFF.

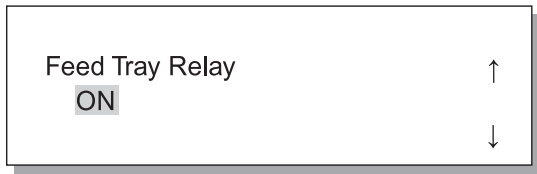

7 Press the OK Key.

When the screen in step 4 reappears, you can continue setting.

To exit the setting, press the PRINT/PAUSE key.

4.5 Triple-Tray Source

Sets whether or not to include the Standard Feed Tray into feed trays for selection when "Auto tray selection" is selected in "Paper feed tray" of the printer driver.

Useful Feature

Turn ON in the following cases:

- If you set paper of different sizes in the feed trays and the Standard Feed Tray respectively and perform printing by automatically selecting the desired paper from three different sizes according to the data.
- If you use paper in the Standard Feed Tray for "4.4 Feed Tray Relay" of the menu setting.

Turn OFF in the following case:

- If you want to set various types of paper such as postcards, envelopes, and card stock in the Feed Tray each time.

Settings

OFF	The Standard Feed Tray is not selected.
ON	The Standard Feed Tray is selected.

1 Press the MENU Key.

2 Press the or key to display "Configuration."

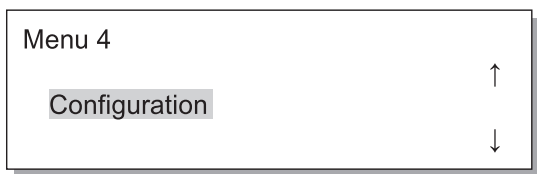

3 Press the OK Key.

4 Press the or key to display "Triple-Tray Source."

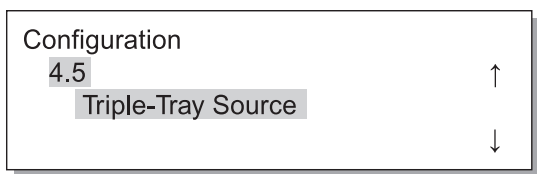

5 Press the OK Key.

The submenu of Triple-Tray Source is displayed.

6 Press the or key to select ON or OFF.



7 Press the OK Key.

When the screen in step 4 reappears, you can continue setting.

To exit the setting, press the PRINT/PAUSE key.