

4.6 Job Separation

The setting of Job separation (set with the printer driver) can be changed while printing of the current job is performed.

Settings

| | |
|----------------|---|
| OFF | Job Separation is not performed. |
| Between Jobs | Separation paper is inserted between jobs. |
| Every Division | Separation paper is inserted every division. When collated printing is directed by the printer driver, separation paper is inserted between sets. When non collated printing is directed, separation paper is inserted between pages. |



- When inserting separation paper, specify the feed tray separately. "5.3 Separation Paper" p.2-36
- If "5.3 Separation Paper" is set to "Off," printing stops for a few seconds in place of insertion of separation paper.
- Although Job Separation can also be set on the "Options" tab of the printer driver, you can temporarily stop printing with the PRINT/ PAUSE Key and change or reset this function on the printer.
- If an optional HC Finisher is connected, "Punching" and "Add Cover" of the HC Finisher can also be set with this function.

1 Press the MENU Key.

2 Press the or key to display "Configuration."

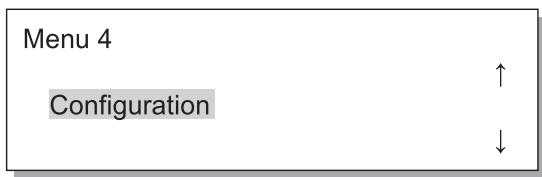

3 Press the OK Key.

4 Press the or key to display "Job Separation."

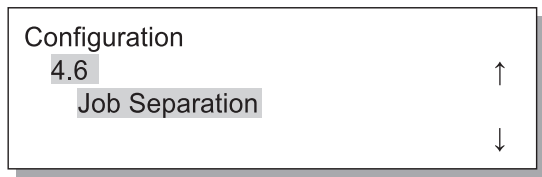

5 Press the OK Key.

The submenu of Job Separation is displayed.

6 Press the or key to select.

7 Press the OK Key.

When the screen in step 4 reappears, you can continue setting.

To exit the setting, press the PRINT/PAUSE key.

4.7 Print Density

You can manually change the print density.

The density of overall printing is set. To adjust specific colours or to change the halftone reproduction method, use the "Image processing" tab of the printer driver to adjust or process the image using the application software.

⊙ Settings

| | |
|-----------------|--------------|
| Density-Level 5 | Dark |
| Density-Level 4 | Medium dark |
| Density-Level 3 | Standard |
| Density-Level 2 | Medium light |
| Density-Level 1 | Light |



Although Print Density can also be set on the "Options" tab of the printer driver, you can temporarily stop printing with the PRINT/PAUSE Key and change or reset this function on the printer.

1 Press the MENU Key.

2 Press the or key to display "Configuration."

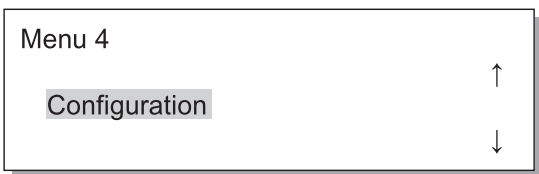

3 Press the OK Key.

4 Press the or key to display "Print Density."

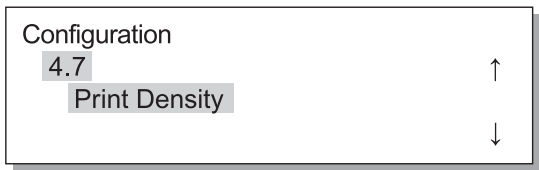

5 Press the OK Key.

The submenu of Print Density is displayed.

6 Press the or key to select the desired density.

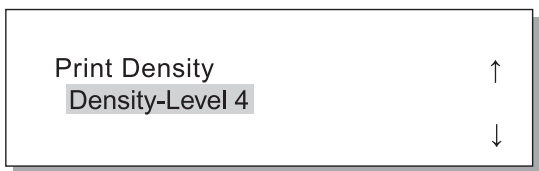

7 Press the OK Key.

When the screen in step 4 reappears, you can continue setting.

To exit the setting, press the PRINT/PAUSE key.

4.8 Paper Ejection



Sets the position and adjustment of the Eject Wing and the Auto Stacking Tray.

 If an optional HC Finisher is connected, this menu is not displayed.

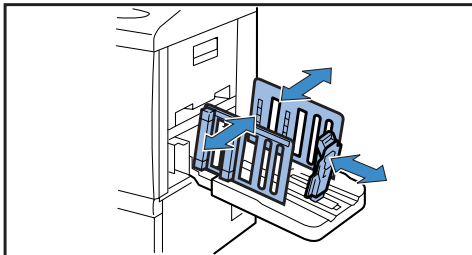
Settings

| | |
|-----------------------------|--|
| 4.8.1 Eject Wing | <p>Adjusts the Eject Wing so that the position changes for proper paper arrangement when printed paper is ejected.</p> <p>Auto: The Eject Wing is automatically adjusted to optimum position based on the type and size of paper.</p> <p>Special: The Eject Wing can be set according to special paper. For details, contact your local dealer (or service representative).</p> |
| 4.8.2 Stack Guide | <p>Selects the method of adjusting the positions of the Side Guides and the End Guide.</p> <p>Auto: The positions of the Side Guides and the End Guide are automatically adjusted according to the type, size, and orientation of paper.</p> <p>Adjusted Position: Since the guides of the Auto Stacking Tray move automatically according to the paper size, the set positions cannot be changed by hand. Use this setting when a little wider (narrower) space is desired depending on the paper. Set the positions in 4.8.3.</p> <p>OFF: The Stack Guides are not adjustable. If paper of larger than 320mm × 432 mm (12⁵/₈" × 17") is used for printing, set "OFF" and fold the Stack Guide.</p> |
| 4.8.3 Stack Guide Adjust | <p>The positions of the Side Guides and End Guide can be specified in 1 mm (0.04") increments when "Adjusted Position" is selected in "4.8.2 Stack Guide."</p> <p>Side Guides: -20 (narrower) mm to +20 (wider) mm (-¹³/₁₆"(narrower) to +¹³/₁₆"(wider)) than paper size</p> <p>End Guide: -20 (to left) mm to +20 (to right) mm (-¹³/₁₆"(to left) to +¹³/₁₆"(to right)) from paper size</p>  |
| 4.8.4 Shifting Guide | <p>When printing is complete, if you press the Stack Guide Open Button, the Stack Guides move outward to allow easy removal of prints. The guides to be moved at this time are specified.</p> <p>For the Stack Guide Open Button, refer to p.1-4.</p> <p>End Guide: Only the End Guide moves outward.</p> <p>Side Guides: Only the Side Guides move outward.</p> <p>End and Side Guides: Both the End Guide and Side Guides move outward.</p> |

- If "Auto" or "OFF" has been selected in "4.8.2 Stack Guide," when "4.8.3 Stack Guide Adjust" is selected, the setting of "4.8.2 Stack Guide" is changed to "Adjusted Position."
- The setting of "4.8.3 Stack Guide Adjust" is cancelled and changed to "Auto" in the following cases.
 - The power is turned off and then on again.
 - The printer is activated from the sleep or stand-by mode.
 - Another paper size is selected that is different from what you set on the "Stack Guide Adjust".
 - "Auto" is selected for "4.8.2 Stack Guide."

- 1 Press the MENU Key.
- 2 Press the  or  key to display "Configuration."

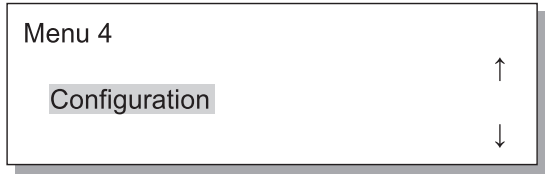



- 3 Press the OK Key.

4.8.1 Eject Wing

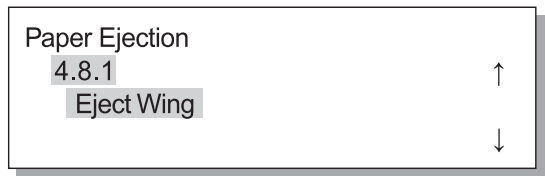
- 1 Ensure that "Eject Wing" is displayed.



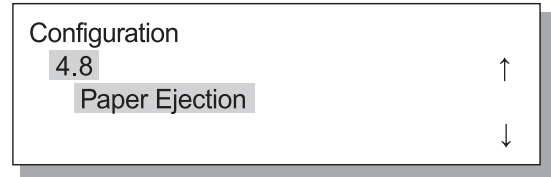

- 2 Press the OK Key.

- 4 Press the  or  key to display "Paper Ejection."



- 5 Press the OK Key.

The submenu of "Paper Ejection" is displayed.

- 3 Press the  or  key to select.





- 4 Press the OK Key.

When the screen in step 1 reappears, you can continue setting.



To exit the setting, press the PRINT/PAUSE key.

4.8.2 Stack Guide

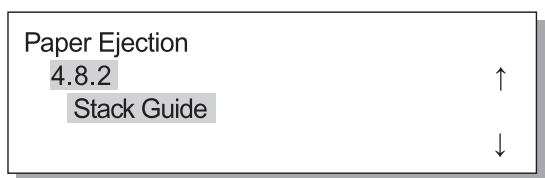
- 1 Press the  or  key to display "Stack Guide."



- 2 Press the OK Key.

- 3 Press the  or  key to select the method of adjusting the positions.

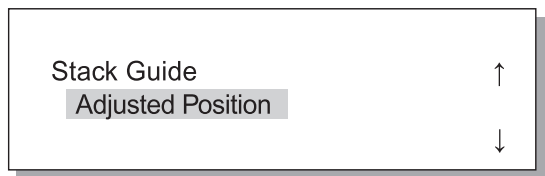



- 4 Press the OK Key.

When the screen in step 1 reappears, you can continue setting.

If "Adjusted Position" is selected, adjust the amount of movement in 4.8.3.



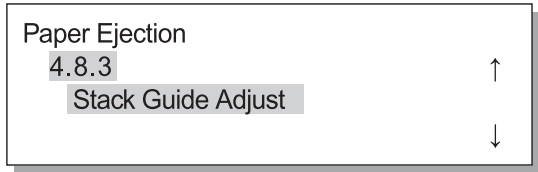

To exit the setting, press the PRINT/PAUSE key.

4.8.3 Stack Guide Adjust

- 1 Press the  or  key to display "Stack Guide Adjust."



- 2 Press the OK Key.

- 3 To adjust the Side Guide positions, press the  or  key, and to adjust the End Guide position, press the  or  key.

Only the arrow that corresponds to the pressed key is displayed therefore the relevant value changes.

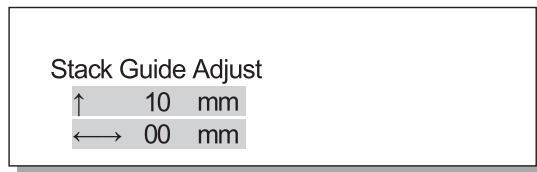



- 4 After setting is complete, press the OK Key.

When the screen in step 1 reappears, you can continue setting.



To exit the setting, press the PRINT/PAUSE key.

4.8.4 Shifting Guide

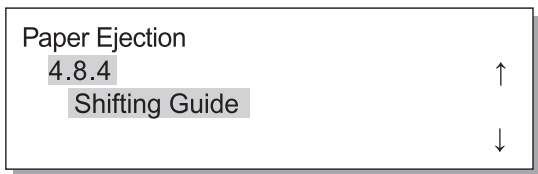
- 1 Press the  or  key to display "Shifting Guide."



- 2 Press the OK Key.

- 3 Press the  or  key to select.

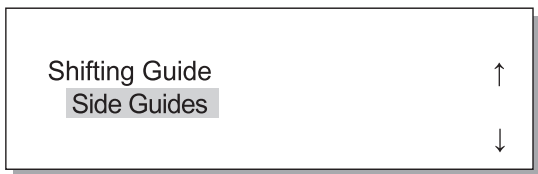



- 4 Press the OK Key.

When the screen in step 1 reappears, you can continue setting.



To exit the setting, press the PRINT/PAUSE key.

4.9 Temp Data Clear

If a check mark is placed at [Keep the last page of the job in the printer.] in [Controller setting 2] - [Initial setting] of [Administrator] of RISO Console, the last page of previous printing (last sheet in case of duplex printing) is left in the controller as retained data. If retention of data after printing is not desired because of a confidential document, the data can be cleared.



 To clear the temporary data when printing stops temporarily, use "Menu 7 Job Clear" to clear the current job and then clear the temporary data.
"Menu 7 Job Clear"  p.2-55

1 Press the MENU Key.

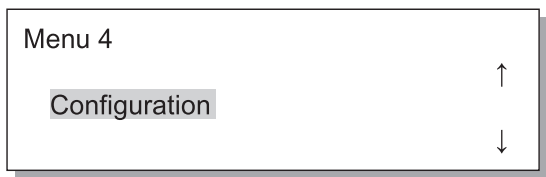
2 Press the  or  key to display "Configuration."



3 Press the OK Key.

4 Press the  or  key to display "Temp Data Clear."

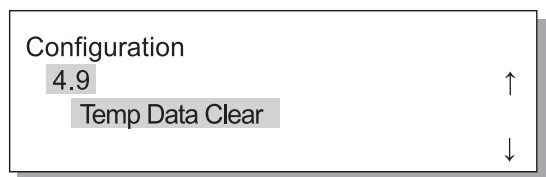

5 Press the OK Key.



6 Check the message. To clear the data, press the OK Key.

Message "Executing ..." is displayed and the data is cleared and the screen returns to the Step 4. If the CANCEL Key is pressed, the screen returns to the step 4.

To exit the setting, press the PRINT/ PAUSE Key.

4.10 Image Area (Maximum Print Area)

With this machine, a certain area of space is left along the edges of paper regardless of the original size. Normally, use the setting "Standard." If the image is larger than the printable area, the relevant part of the image is not printed. (Reduction is not performed.)

⊙ Settings

| | |
|----------|---|
| Standard | Printing can be performed into the area 3mm ($1/8$ ") inside from the sides of paper. Print Area : 310mm × 454mm ($12^{3/16}$ " × $17^{7/8}$ ") |
| Maximum | Printing can be performed into the area 1mm (0.04") inside from the sides of paper. Maximum Print Area : 314mm × 458mm ($12^{3/8}$ " × $18^{5/16}$ ") |

- If the image is larger than the guaranteed print area (Ⓒ p.viii), deterioration of print quality such as blur of characters and pictures may occur depending on the original image.
- Even if the paper size is larger than 316mm × 460mm ($12^{7/16}$ " × $18^{1/8}$ "), the actual maximum printable area is 314mm × 458mm ($12^{3/8}$ " × $18^{5/16}$ ").
- If "Maximum" is selected, the interior of the machine and the paper may be stained with ink.

1 Press the MENU Key.

2 Press the or key to display "Configuration."

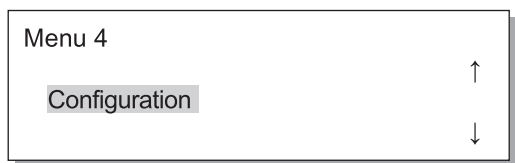

3 Press the OK Key.

4 Press the or key to display "Image Area"

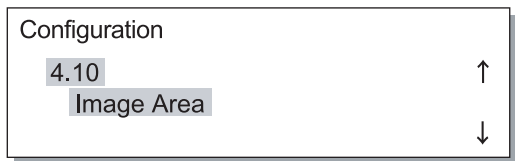

5 Press the OK Key.

The submenu of "Image Area" is displayed.

6 Press the or key to select.



7 Press the OK Key.

When the screen in step 4 reappears, you can continue setting.

To exit the setting, press the PRINT/ PAUSE Key.



4.11 Cover Sheet Tray (Only when the HC Finisher is connected)

Set the size and type of paper to be loaded in the Cover Sheet Tray in the optional Finisher. Be sure to set them when you have changed the type or size of paper.

⊙ Settings

| | |
|-------------------|---|
| 4.11.1 Paper Size | Can be selected from Auto, A3, B4, A4, B5, A4-R, B5-R, Ledger, Legal, Letter, Letter-R. |
|-------------------|---|

1 Press the MENU Key.

2 Press the  or  key to display "Configuration."

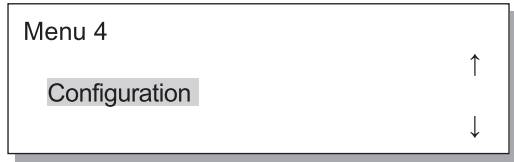

3 Press the OK Key.

4 Press the  or  key to display "Cover Sheet Tray"

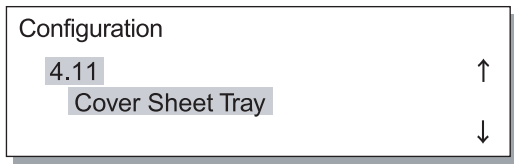



5 Press the OK Key.

The submenu of "Cover Sheet Tray" is displayed.

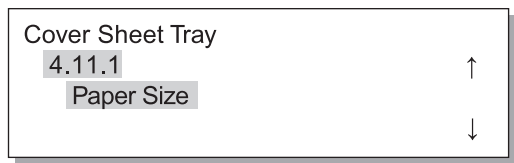
6 Check that "Paper Size" is displayed.



7 Press the OK Key.

8 Press the  or  key to select the desired size.



9 Press the OK Key.

When the screen in step 1 reappears, you can continue setting. To exit the setting, press the PRINT/PAUSE key.

Menu 5 Administration

Sets basic information of the printer such as paper type entry, maintenance, and initial setting.
The items set here are effective until the setting is changed regardless of when the power is on or off.



⦿ Functions

The functions that can be set are shown below.

- 5.1 Paper Size Entry [p.2-32](#)
Five paper sizes such as non-standard sizes can be registered.
- 5.2 Paper Type Entry [p.2-33](#)
Five paper types including printer recommended paper, standard paper, and any other types of paper can be registered.
- 5.3 Separation Paper [p.2-36](#)
Set the feed tray to be exclusively used for separation paper.
- 5.4 Count Management [p.2-37](#)
The number of printed sheets that can be checked.
- 5.5 Head Maintenance [p.2-40](#) "Ink Cartridge Replacement" [p.3-18](#)
Perform maintenance of the ink head in the following cases:
 - Part of print image is blurred.
 - A certain colour is too light.
 - The printer has not been used for a long time.
- 5.6 Configuration Information Print [p.2-42](#)
Print the settings in a list.
- 5.7 Network Configuration [p.2-45](#)
Set the DHCP, IP address, subnet mask, and default gateway if the printer is used through network.
- 5.8 Initial Setting [p.2-46](#)
Set basic conditions such as details of sleep, beep sound, language, and metric/inch switch.

How to Enter the Administration Menu

1 Press the MENU Key.

2 Press the  or  key to display "Administration."

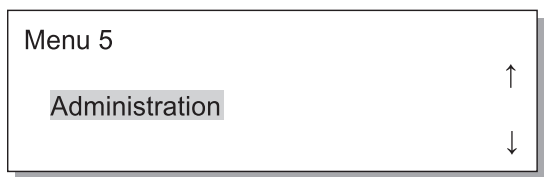

3 Press the OK Key.

A confirmation screen is displayed.

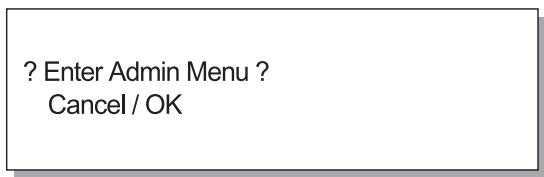

4 Check the message and press the OK Key.

"5.1 Paper Size Entry" is displayed.
If the CANCEL key is pressed, the screen in step 2 will reappear.

5.1 Paper Size Entry

Five non-standard paper sizes can be registered.

When using non-standard size paper, be sure to register the size in advance.

Registered values are displayed in Paper Size of "4.1.1 Standard Feed Tray," "4.2.1 Feed Tray 1," and "4.3.1 Feed Tray 2."

If the paper sizes have been registered, the registered values will be displayed.

Range of paper size that can be set

| | Width (Vertical) | Length (Horizontal) |
|------------------------------|---|--|
| Printer | 90 - 340mm ($3\frac{9}{16}$ - $13\frac{3}{8}$ ") | 148 - 550mm ($5\frac{13}{16}$ - $21\frac{5}{8}$ ") |
| Printer with HC Finisher | 100 - 330mm ($3\frac{15}{16}$ - 13") | 148 - 488mm ($5\frac{13}{16}$ - $19\frac{3}{16}$ ") |
| Printer with HC Auto Stacker | 100* - 305mm ($3\frac{15}{16}$ - $12\frac{1}{16}$ ") | 148 - 432mm ($5\frac{7}{8}$ - $17\frac{1}{16}$ ") |

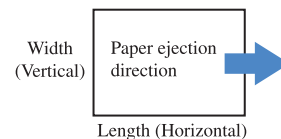

*When using "Offset output" function:131mm



- Be sure to set this item before proceeding to "4.1.1 Standard Feed Tray," "4.2.1 Feed Tray 1," and "4.3.1 Feed Tray 2."
- The registered sizes can also be changed.
- To clear a registered paper size, set the paper size to "000 mm x 000 mm."
If a paper size is registered for the Standard Feed Tray or another feed tray and paper of the registered size is actually set, the size cannot be deleted from the choices of "Paper Size."
- If an optional HC Finisher is connected, the paper sizes that can be used depend on the Finisher functions to be used. For details, see "HC5500 User's Manual for Printer Driver."

1 Use steps 1 to 4 (p.2-31) to display "Administration."

2 Press the or key to display "Paper Size Entry".

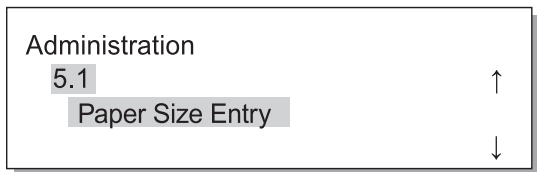

3 Press the OK Key.

4 Press the or key to display the desired number to be registered.

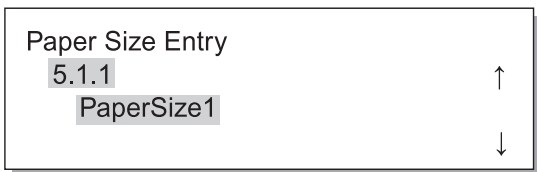

5 Press the OK Key.

The submenu of "Paper Size Entry" is displayed.

6 Press the keys to move the cursor, and press the keys to enter the paper size.

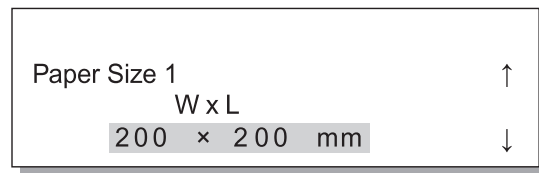

7 Press the OK Key.

To exit the setting, press the PRINT/PAUSE key.



5.2 Paper Type Entry

If any paper other than printer recommended paper is used or paper is not fed properly, it could result in poor print quality. You should register the paper type and feeding according to the paper type specifications. The registered setting is displayed in Paper Type of "4.1.2 Standard Feed Tray," "4.2.2 Feed Tray 1," and "4.3.2 Feed Tray 2."

Also if printer recommended paper is used and paper is not fed properly because of operating environment or the like, the setting can be changed.

When changing the setting or registering paper other than printer recommended paper, contact your local dealer (or service representative) for consultation. Advice on proper setting will be given.

⊙ Settings

| | | |
|---|---|--|
| <p>Paper Type 1 - 5</p> | <p>Register required information on the paper type and paper feed for paper of which a new size is registered in "5.1 Paper Size Entry" or paper other than recommended paper.</p> | <ul style="list-style-type: none"> ● Registration Sets whether or not the registered paper type is displayed as a choice when setting a paper type in "4.1.2," "4.2.2" or "4.3.2." ON: This item is displayed. OFF: This item is not displayed. ● Paper Type Determine the image quality (colour matching) by selecting the paper type. Select the same item as the paper to be used for printing. <p> When printing, specify the same item in [Paper type] of the [Main setting] tab of the printer driver screen.</p> <ul style="list-style-type: none"> • Standard Paper 1 • High-Quality 1 • High-Quality 2 • Envelope • Card • Card-IJ <ul style="list-style-type: none"> ● Paper Feed Control Select the paper thickness. <ul style="list-style-type: none"> • Standard • Card • Thin/Light • Envelope • Custom: Can be set in advance. For details, contact your local dealer (or service representative) for inquiry. |
| <p>Standard Paper 1 High-Quality 1 High-Quality 2 Envelope Card Card-IJ</p> | <p>If paper load in the Standard Feed Tray or another feed tray is not fed properly, change the Paper Feed Control for the relevant paper.</p> <p> If the paper type is Envelope, Card or Card IJ, Paper Feed Control cannot be changed.</p> | <ul style="list-style-type: none"> ● Paper Feed Control Select paper thickness. <ul style="list-style-type: none"> • Standard • Card • Thin/Light • Envelope • Custom: Can be set in advance. For details, contact your local dealer (or service representative) for inquiry. |

 If the following settings are made concerning the paper, the paper type is not displayed at "4.2.2 Feed Tray 1" and "4.3.2 Feed Tray 2." (These types of paper cannot be used in these trays.)

- Paper Type: Envelope, Card, Card-IJ
- Paper Feed Control: Envelope, Postcard



5.2.1 Registering a New Paper Type

1 Use steps 1 to 4 (p.2-31) to display "Administration."

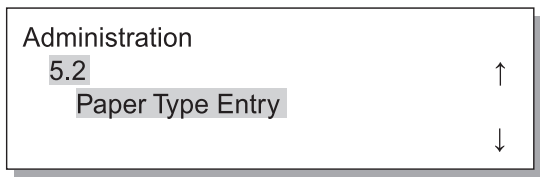
2 Press the  or  key to display "Paper Type Entry."



3 Press the OK Key.

4 Press the  or  key to display the desired number to be registered.

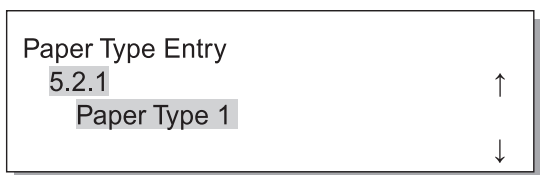



5 Press the OK Key.

The submenu of Registration appears.

Set whether or not to display the registered paper type (1 to 5) in "Paper Type."

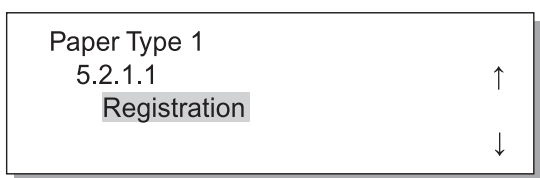
6 Press the OK Key when "Registration" is displayed.



7 Press the  or  key to select ON or OFF.

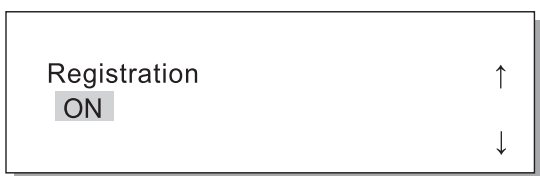

8 Press the OK Key.

The screen in step 6 appears again.

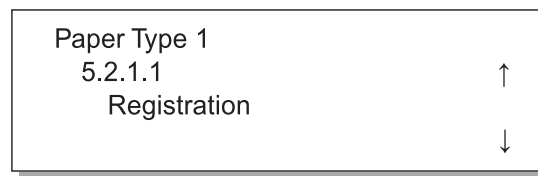

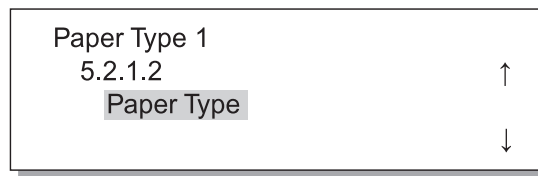

Set the Paper Type.

9 Press the  or  key to display "Paper Type."



10 Press the OK Key.

The submenu of paper type appears.

11 Press the  or  key to select the desired paper type.

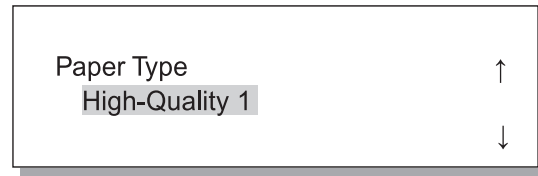

12 Press the OK Key.

The screen in step 9 appears again.

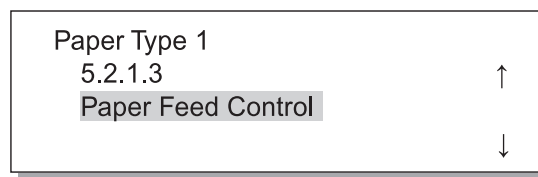

Perform Paper Feed Control.

13 Press the  or  key to display "Paper Feed Control."



14 Press the OK Key.

The submenu of paper feed control appears.

15 Press the  or  key to select the desired paper type.



16 Press the OK Key.

The screen in step 13 reappears, you can continue setting.

To exit the setting, press the PRINT/PAUSE key.



5.2.6- Changes the Paper feed control of the existing paper type.

1 Use steps 1 to 4 (p.2-31) to display "Administration."

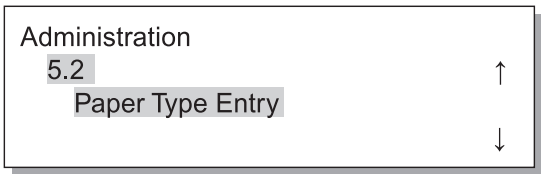
2 Press the  or  key to display "Paper Type Entry."



3 Press the OK Key.

4 Press the  or  key to display the desired paper type to change the settings.

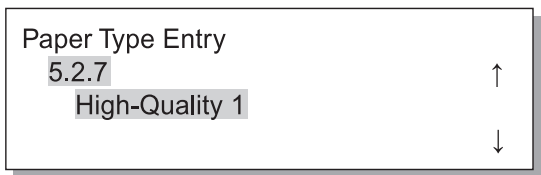



5 Press the OK Key.

The submenu of Paper feed control appears.

Perform paper feed control.

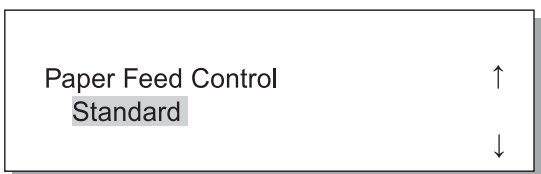
6 Press the OK Key.



7 Press the  or  key to select the desired Paper feed control.



8 Press the OK Key.

When the screen in step 6 reappears, you can continue setting.

To exit the setting, press the PRINT/PAUSE key.

5.3 Separation Paper

If you use "4.6 Job Separation", specify the feed tray in which the separation paper is loaded.

⊙ Settings

The separation paper can be used even if the size and the orientation are different from those of the printer paper.

| | |
|--------------------|---|
| OFF | The separation paper tray is not specified. Printing stops for a few seconds in place of insertion of separation paper. |
| Standard Feed Tray | The Standard Feed Tray is used for separation paper. |
| Feed Tray 1 | Feed Tray 1 is used for separation paper. |
| Feed Tray 2 | Feed Tray 2 is used for separation paper. |



- The separation paper tray is used exclusively for Job Separation. If "Menu 6 Feed Tray Selection" is set to "Auto" and "Menu 4.4 Feed Tray Relay" is set, this feed tray is not used for printing.
- If the separation paper tray runs out of paper during printing, no-paper error will be displayed and printing stops temporarily.
- If a HC Finisher is connected, paper in the separation paper tray can be added as a front cover or a back cover by using the "Add cover" function of the HC Finisher. In this case, specify the tray in which cover sheets are loaded. If "OFF" is set, an error will be displayed when printing is performed.

Caution in the following case

If paper larger than the paper for printing or paper of a different orientation is specified as separation paper, the stack guides are spread according to the larger paper size. Printed paper, therefore, may not be arranged properly.

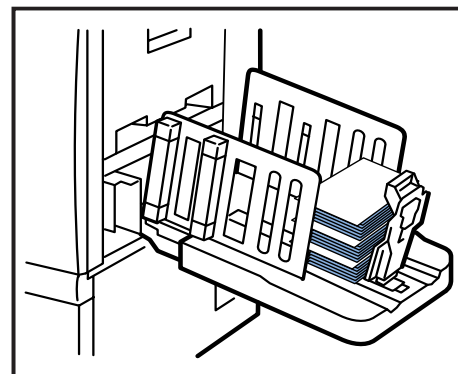

1 Use steps 1 to 4 (p.2-31) to display "Administration."

2 Press the  or  key to display "Separation Paper."

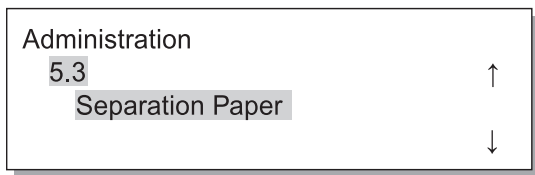

3 Press the OK Key.

The submenu of separation paper appears.

4 Press the  or  key to set.

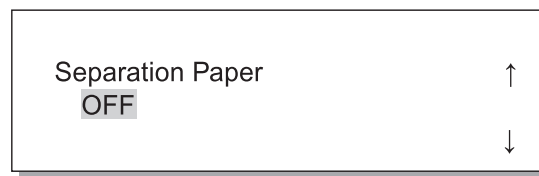

5 Press the OK Key.

When the screen in step 1 reappears, you can continue setting.

To exit the setting, press the PRINT/PAUSE key.

5.4 Count Management

The number of printed sheets can be checked.

- The number of sheets that have been ejected in the Paper Receiving Tray is displayed.
- For copy count, in duplex printing, each side is counted, and therefore one sheet of both sides is counted by two. Since the paper transfer path varies depending on the functions that you use, one sheet in simplex printing may be counted as two.
- For Count Pattern, one sheet is counted as one regardless of simplex or duplex printing.

Settings

| | |
|------------------------|--|
| 5.4.1 Copy Count | The total number of sheets that have been printed until now is displayed. Paper on which printing is not performed such as separation paper is also counted. |
| 5.4.3 Count Pattern | Specify a count number for which conditions such as paper size, simplex/duplex, and colour/monochrome are determined. The relevant number of sheets is displayed. Paper on which printing is not performed such as separation paper is not counted. |

5.4.2 is not displayed.

In Count Pattern, the number of printed sheets is displayed according to the combined conditions shown below.
The Paper Size Number is as follows.

| | |
|-----------|--|
| Size No.1 | A3 (Ledger) |
| Size No.2 | A4 (Letter) |
| Size No.3 | B4 (Legal) |
| Size No.4 | B5 (Statement) |
| Size No.5 | Foolscap |
| Size No.6 | Irregular paper size of which the length is 320 mm ($12\frac{13}{16}$ ") or more for the Standard Feed Tray or 316 mm ($12\frac{5}{8}$ ") or more for other feed trays |
| Size No.7 | Irregular paper size of which the length is less than 320 mm ($12\frac{13}{16}$ ") for the Standard Feed Tray or less than 316 mm ($12\frac{5}{8}$ ") for other feed trays |

| Count No. | Paper Size Number | Simplex/ Duplex | Colour/ Monochrome |
|-----------|-------------------|-----------------|--------------------|
| 01 | Size No.1 | Simplex | Colour |
| 02 | Size No.2 | | |
| 03 | Size No.3 | | |
| 04 | Size No.4 | | |
| 05 | Size No.5 | | |
| 06 | Size No.6 | | |
| 07 | Size No.7 | | |
| 08 | Size No.1 | Duplex | |
| 09 | Size No.2 | | |
| 10 | Size No.3 | | |
| 11 | Size No.4 | | |
| 12 | Size No.5 | | |
| 13 | Size No.6 | | |
| 14 | Size No.7 | | |

| Count No. | Paper Size Number | Simplex/ Duplex | Colour/ Monochrome |
|-----------|-------------------|-----------------|--------------------|
| 15 | Size No.1 | Simplex | Monochrome |
| 16 | Size No.2 | | |
| 17 | Size No.3 | | |
| 18 | Size No.4 | | |
| 19 | Size No.5 | | |
| 20 | Size No.6 | | |
| 21 | Size No.7 | | |
| 22 | Size No.1 | Duplex | |
| 23 | Size No.2 | | |
| 24 | Size No.3 | | |
| 25 | Size No.4 | | |
| 26 | Size No.5 | | |
| 27 | Size No.6 | | |
| 28 | Size No.7 | | |



5.4.1 Copy Count

1 Use steps 1 to 4 (p.2-31) to display "Administration."

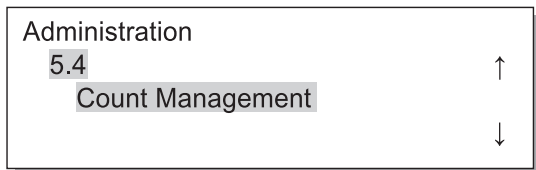
2 Press the  or  key to display "Count Management."



3 Press the OK Key.

4 Press the  or  key to display "Copy Count."

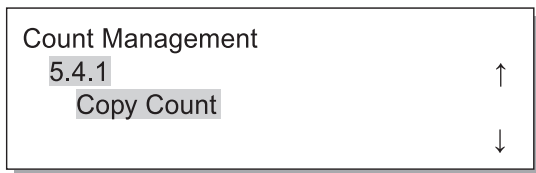

5 Press the OK Key.

The total number of sheets is displayed.

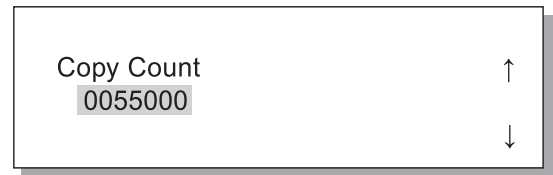

6 After checking is complete, press the OK Key.

When the screen in step 4 reappears, you can continue setting.



To exit the setting, press the PRINT/PAUSE key.

1 Use steps 1 to 4 (p.2-31) to display "Administration."

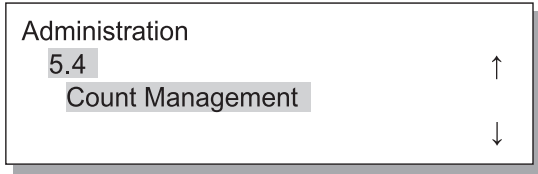
2 Press the  or  key to display "Count Management."





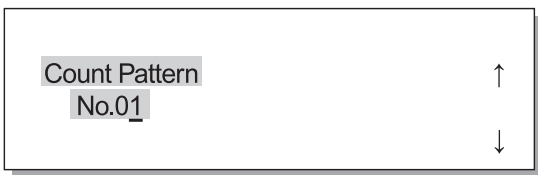

3 Press the OK Key.

4 Press the  or  key to display "Count Pattern."



5 Press the OK Key.

6 Press the   keys to move the cursor, and press the   keys to input the count No. of Count Pattern.

7 Press the OK Key.

The number of sheets of the specified count pattern is displayed.

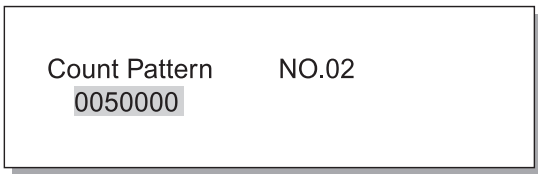

8 After checking is complete, press the OK Key.

When the screen in step 4 reappears, you can continue setting.

To exit the setting, press the PRINT/PAUSE key.

5.5 Head Maintenance

Perform maintenance of the print head section. You can also set the cycle of automatic cleaning. Use this function when there is a problem of image quality. For example, if parts of print images are blurred, white lines appear, a specific colour is light and when the printer will not be used or has not been used for a long time.

In the factory default setting, the cleaning cycle is set to 500 sheets.

Settings



| | |
|--------------------------|---|
| 5.5.4 Hyper-Cleaning | Performed when a warning message is displayed or the head is actually clogged. This cleaning is stronger than Normal Cleaning. Specify the head of K (black), C (cyan), M (magenta) or Y (yellow) respectively to perform cleaning. |
| 5.5.5 Normal Cleaning | Performed to prevent the head section from clogging. Head cleaning for four colours K (black), C (cyan), M (magenta), and Y (yellow) is performed simultaneously. |
| 5.5.6 Cleaning Cycle | Normal Cleaning is automatically performed each time the specified number of sheets are printed. The cleaning cycle can be set to 100 - 3000 sheets in 100 sheet increments. |

 5.5.1 - 5.5.3 are not displayed.

| | |
|-------------------------|--|
| 5.8.50 Head Recovery | The print heads can be cleaned and initialized. When a printing machine is not used for a long period of time, this function is useful. p.2-53 |
|-------------------------|--|



5.5.4 Hyper-Cleaning

1 Use steps 1 to 4 ([p.2-31](#)) to display "Administration."

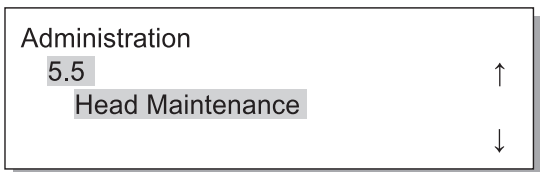
2 Press the  or  key to display "Head Maintenance."



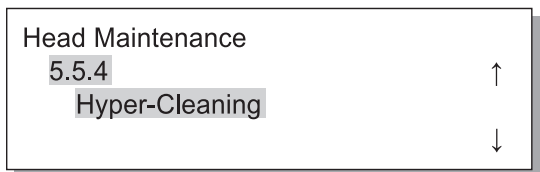

3 Press the OK Key.

4 Press the  or  key to display "Hyper-Cleaning."



5 Press the OK Key.

6 Press the  or  key to select the head to clean.

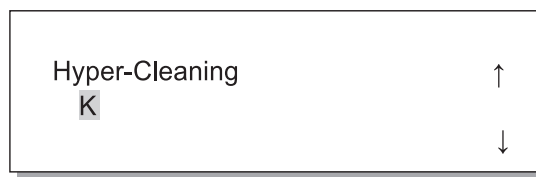

7 Press the OK Key.

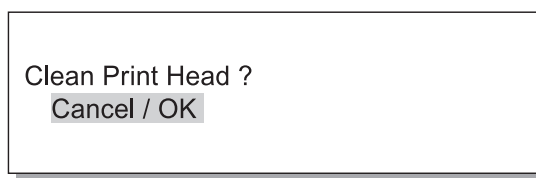



8 After checking the message, press the OK Key.

When message "Cleaning Print Head-K" blinks, cleaning is performed. After cleaning is complete, the screen in step 4 will appear again.

To finish cleaning the setting, press the PRINT/PAUSE key.



5.5.5 Normal Cleaning

1 Use steps 1 to 4 (p.2-31) to display "Administration."

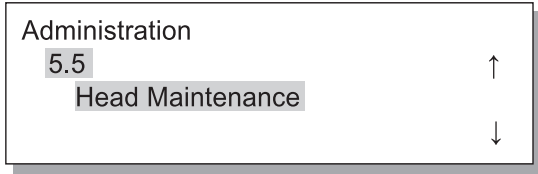
2 Press the  or  key to display "Head Maintenance."



3 Press the OK Key.

4 Press the  or  key to display "Normal Cleaning."

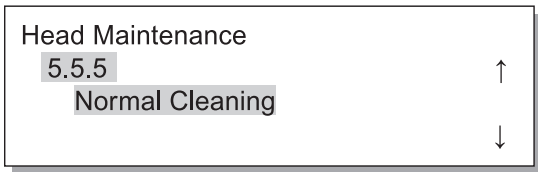

5 Press the OK Key.

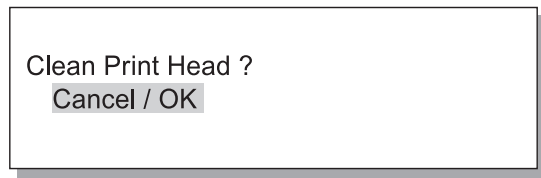

6 After checking the message, press the OK Key.

When message "Cleaning Print Head" blinks, cleaning is performed. After cleaning is complete, the screen in step 4 will appear again.

To exit the setting, press the PRINT/PAUSE key.

2



5.5.6 Cleaning Cycle

1 Use steps 1 to 4 (p.2-31) to display "Administration."

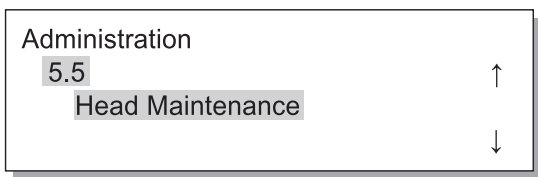
2 Press the  or  key to display "Head Maintenance."



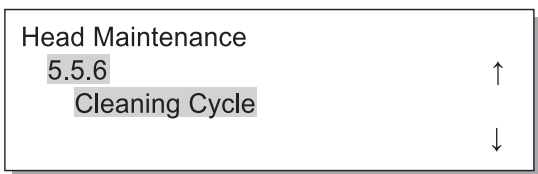

3 Press the OK Key.

4 Press the  or  key to display "Cleaning Cycle."



5 Press the OK Key.

6 Press the  or  key to select the desired cleaning cycle.

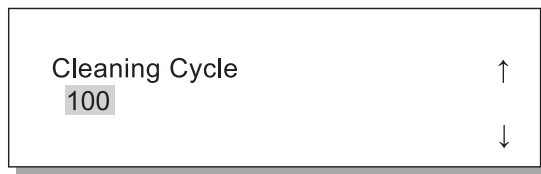

7 Press the OK Key.

The screen in step 4 will reappear.

To exit the setting, press the PRINT/PAUSE key.

5.6 Configuration Information Print

Configuration settings are printed in a list. Current printer settings and menu settings can be checked in a list.

⊙ Settings

| | |
|-----------------------------|--|
| 5.6.1 System Information | Information such as printer memory capacity, firmware version, and IP address can be checked in a list. |
| 5.6.2 Menu Setting | The menu settings made on the operation panel can be checked in a list. |
| 5.6.4 Count Pattern | The result of "5.4.3 Count Pattern" and the count of the finisher function (only if an optional finisher is connected) can be checked in a list. |

Restrictions in configuration information print

- Perform configuration information print when printing is not being performed, for example, when "Ready" is displayed.
- Configuration Information Print can be printed only on paper loaded on the Standard Feed Tray. ("Menu 6 Feed Tray Selection" is automatically set to Standard Feed Tray.)
- For Configuration Information Print, A4-sized paper is required. When "No Paper" is displayed, load A4-sized paper onto the Standard Feed Tray.



The counter of the finisher functions is composed of the Finisher Counter number and the number of times. Finisher Counter number means the finisher function. (Only when the HC Finisher is connected.)

| Finisher Count number | Meaning (function) |
|-----------------------|----------------------------|
| Finisher Counter1 | Punching / 2 holes |
| Finisher Counter2 | Punching / 3 or 4 holes |
| Finisher Counter3 | Stapler / Rear 1 position |
| Finisher Counter4 | Stapler / Front 1 position |
| Finisher Counter5 | Stapler / 2 positions |
| Finisher Counter6 | Booklet / Fold and staple |
| Finisher Counter7 | Booklet / Fold |
| Finisher Counter8 | N/A |
| Finisher Counter9 | Cover Sheet Tray feeding |

 When the number of times is printed as [***], it means that finisher function is not available with your finisher.

5.6.1 System Information

1 Use steps 1 to 4 (p.2-31) to display "Administration."

2 Press the  or  key to display "Config Info Print."

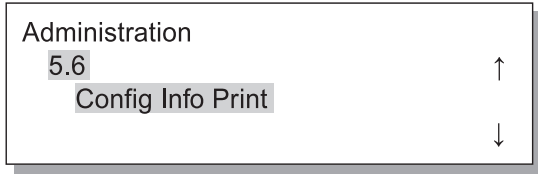

3 Press the OK Key.

4 Press the  or  key to display "System Information."

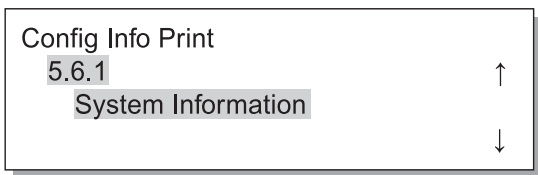

5 Press the OK Key.

6 After checking the message, press the OK Key.

When printing is complete, the screen in step 4 will reappear, and you can continue setting.

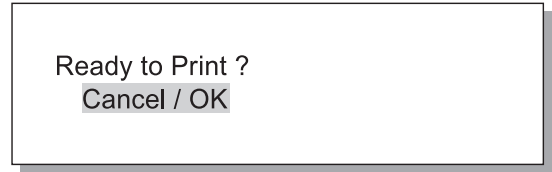

7 Press the PRINT/PAUSE Key.

A list of system information is printed.

2



5.6.2 Menu Setting

1 Use steps 1 to 4 (p.2-31) to display "Administration."

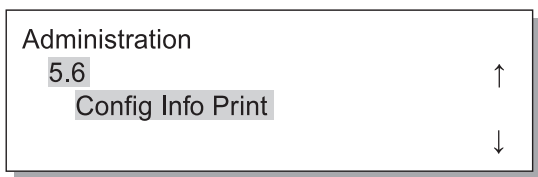
2 Press the  or  key to display "Config Info Print."



3 Press the OK Key.

4 Press the  or  key to display "Menu Setting."

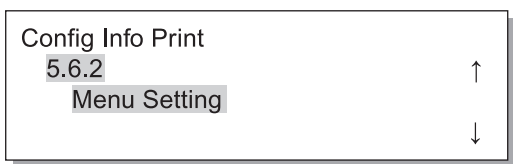

5 Press the OK Key.

6 After checking the message, press the OK Key.

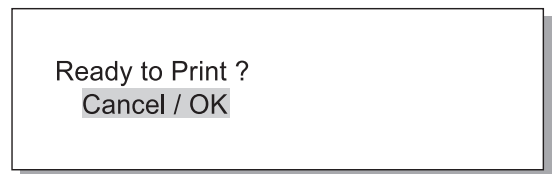

To cancel the setting, press the Cancel key.



7 Press the PRINT/PAUSE key.



A list of the settings is printed.

1 Use steps 1 to 4 (p.2-31) to display "Administration."

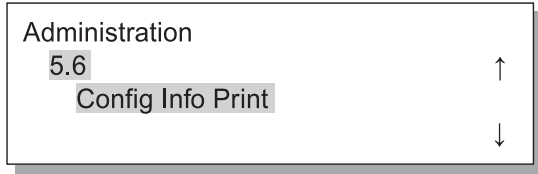
2 Press the  or  key to display "Config Info Print."



3 Press the OK Key.

4 Press the  or  key to display "Count Pattern."

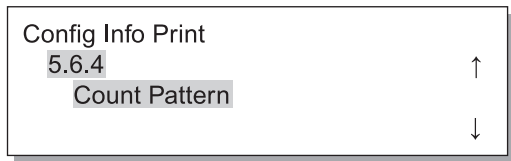

5 Press the OK Key.

6 After checking the message, press the OK Key.

To cancel the setting, press the Cancel key.

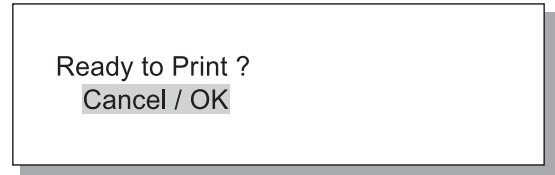

7 Press the PRINT/PAUSE key.

A list of "5.4.3 Count Pattern" and the count of the finisher function (only if an optional finisher is connected) is printed.

5.7 Network Configuration

If the printer is connected to a network and all the conditions shown below are satisfied, you can register the network configuration. If the conditions below are not satisfied, you can check the settings.

- DHCP OFF
- IP address is "000.000.000.000"



To change the setting, use "Administrator" of RISO Console or supplied software "RISO IP Setting Tool."

The settings will be effective after the printer is restored from the sleep mode. For details, consult your network administrator.

Settings

| | | |
|----------|---|--|
| DHCP ON | The IP address, subnet mask, and default gateway are obtained from the DHCP server, and the settings of the printer controller are automatically set and registered.. | |
| DHCP OFF | Set the following three items on the Operation Panel. | |
| | IP address | Input the IP address of the printer. Set the address in the range of "000.000.000.000" - "255.255.255.255." |
| | Subnet mask | Input the subnet mask address. Set the address in the range of "000.000.000.000" - "255.255.255.255." |
| | Default gateway | Input the default gateway address. Set the address in the range of "000.000.000.000" - "255.255.255.255." |

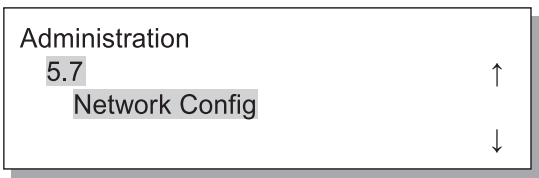

1 Use steps 1 to 4 (p.2-31) to display "Administration."

2 Press the  or  key to display "Network Config."



3 Press the OK Key.

Set the DHCP.





4 Press the  or  key to select ON or OFF.



5 Press the OK Key.

If you have selected ON, proceed to step 10.



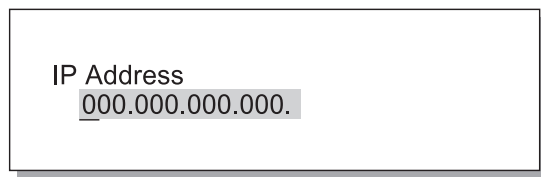

Input the IP address.

6 Press the   keys to move the cursor, and press the   keys to enter the value.



7 Press the OK Key.



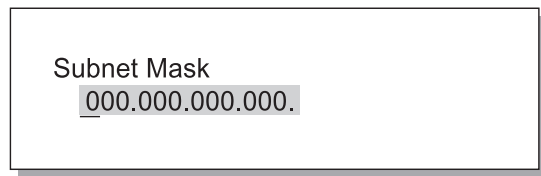

Input the subnet mask address.

8 Press the   keys to move the cursor, and press the   keys to enter the values.



9 Press the OK Key.

Input the default gateway address.

- 10** Press the   keys to move the cursor, and press the   keys to enter the values.

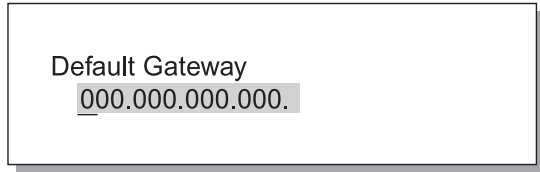

- 11** After checking the message, press the **OK** Key.

Message "Registered. Restart Printer" is displayed.



- 12** Press the **Sleep Key** to turn off the power and then on again.

After message "Shutting Down" disappears and the Power Key becomes orange, press the Sleep Key again to turn ON the power.

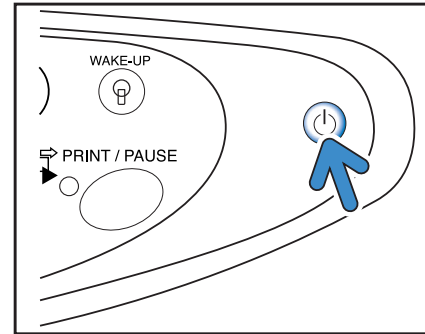

5.8 Initial Setting

Basic setting such as details of sleep, buzzer sound, language, metric/inch switch, and print head nozzle initialization is made here.

AAA indicates factory default setting.

⦿ Settings

| | |
|-------------------------------|---|
| 5.8.1 Sleep | Set whether or not to use the sleep mode for suppressing power consumption when the printer is not used for a certain time. ON : Sleep is enabled. OFF : Sleep is disabled. |
| 5.8.2 Waiting Time | Set the time that elapses until the printer enters the sleep mode if the sleep function is enabled. The time can be set to 1 - 99 minutes. 60 |
| 5.8.3 Beep Sound - Key | Set whether or not to sound the beeper when a key on the Operation Panel is pressed. ON : Beep sound is enabled. OFF : Beep sound is disabled. |
| 5.8.4 Beep Sound - Status | Set whether or not to sound the beeper when, for example, printing is completed. ON : Beep sound is enabled. OFF : Beep sound is disabled. |
| 5.8.5 Beep Sound - Error | Set whether or not to sound the beeper when an error such as paper jam occurs. ON : Beep sound is enabled. OFF : Beep sound is disabled. |
| 5.8.7 Displayed Language | Set the language displayed on the Operation Panel. Japanese/ UK English /US English/French/German/Italian/Spanish/Portuguese |
| 5.8.8 Metric/Inch Switch | Select the Metric or Inch unit for display on the Operation Panel. mm : Displayed in mm. inch: Displayed in inch. |
| 5.8.17 Tray Selection Rule | Sets the condition for selecting a tray using the auto tray selection function. Size: A tray in which paper of the size specified by the controller is set will be selected with auto tray selection. Size & Type : A tray in which paper of the size and type specified by the controller is set will be selected with auto tray selection. |



| | |
|------------------------------|--|
| 5.8.18 Print Mode Auto-ON | Sets whether or not the print mode is automatically turned on when the printer is not used for a certain time with the print mode OFF. ON: The print mode will be automatically turned off. OFF: The print mode will not be turned off. |
| 5.8.19 Print Auto-ON Time | Sets the time that elapses until the print mode is turned on when "Print Mode Auto-ON" is set to "ON." The time can be set to 1 to 60 minutes. 5 |
| 5.8.20 Menu Auto-Shut OFF | Sets whether or not the print mode is automatically turned off when no operation is made for a certain time on the menu setting screen. ON: The print mode will be automatically turned off. OFF: The print mode will not be turned off. |
| 5.8.21 Menu Shut OFF Time | Sets the time that elapses until the print mode is turned off when "Menu Auto-Shut OFF" is set to "ON." At this time, the current menu settings will not be retained. The time can be set to 1 to 60 minutes. 5 |
| 5.8.22 Stand-by | Sets whether or not the printer enters the stand-by mode to reduce power consumption when the printer is not used for a certain time. In the stand-by mode, when the printer receives data from a computer, the printer is automatically started and starts printing. ON: The stand-by mode is enabled. OFF: The stand-by mode is not used. |
| 5.8.23 Stand-by Period | Sets the time that elapses until the printer enters the stand-by mode when "Stand-by" is set to "ON." The time can be set to 1 to 99 minutes. 5 |
| 5.8.50 Head Recovery | Performs powerful cleaning of the print head nozzles to restore them to the initial state after the printer is not used for a long time. |



5.8.6, 5.8.9 - 5.8.16, 5.8.24 -5.8.49 are not displayed.



5.8.1 Sleep

1 Use steps 1 to 4 (p.2-48) to display "Administration."

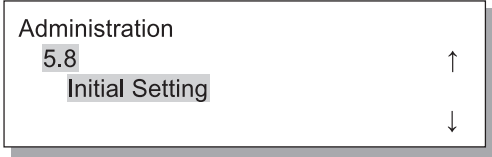
2 Press the  or  key to display "Initial Setting."



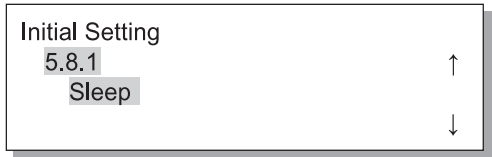

3 Press the OK Key.

4 Press the  or  key to display "Sleep."



5 Press the OK Key.

6 Press the  or  key to select ON or OFF.





7 Press the OK Key.

When the screen in step 4 reappears, you can continue setting.

To exit the setting, press the PRINT/PAUSE key.



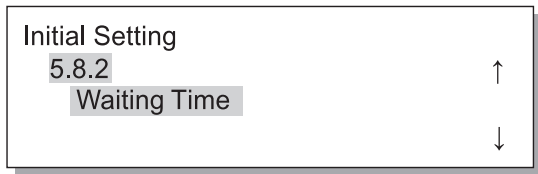

5.8.2 Waiting Time

1 Use steps 1 to 3 of "5.8.1 Sleep" (p.2-48) to display "Initial Setting."

2 Press the  or  key to display "Waiting Time."



3 Press the OK Key.

4 Press the   keys to move the cursor, and press the   keys to input the Waiting Time.

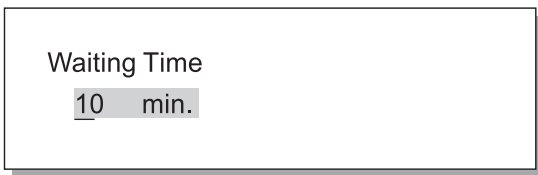

5 Press the OK Key.

When the screen in step 2 reappears, you can continue setting. To exit the setting, press the PRINT/PAUSE key.



5.8.3 Beep Sound -Key

1 Use steps 1 to 3 of "5.8.1 Sleep" (p.2-48) to display "Initial Setting."

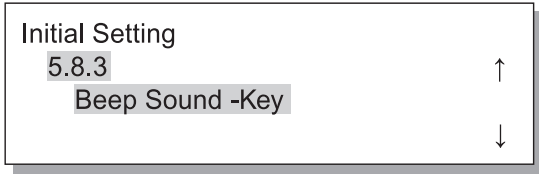
2 Press the  or  key to display "Beep Sound -Key."



3 Press the OK Key.

4 Press the  or  key to select ON or OFF.

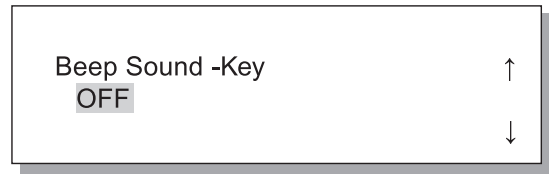

5 Press the OK Key.

When the screen in step 2 reappears, you can continue setting.

To exit the setting, press the PRINT/PAUSE key.

2



5.8.4 Beep Sound -Status

1 Use steps 1 to 3 of "5.8.1 Sleep" (p.2-48) to display "Initial Setting."

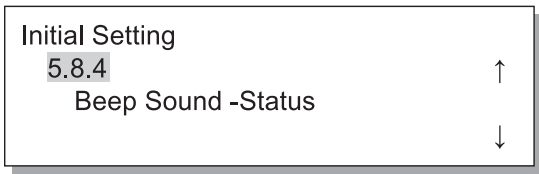
2 Press the  or  key to display "Beep Sound -Status."



3 Press the OK Key.

4 Press the  or  key to select ON or OFF.

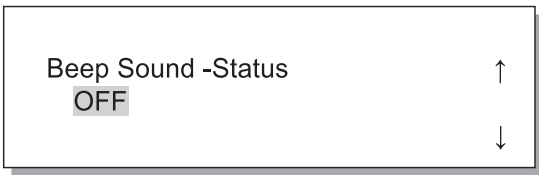



5 Press the OK Key.

When the screen in step 2 reappears, you can continue setting.

To exit the setting, press the PRINT/PAUSE key.



5.8.5 Beep Sound -Error

1 Use steps 1 to 3 of "5.8.1 Sleep" (p.2-48) to display "Initial Setting."

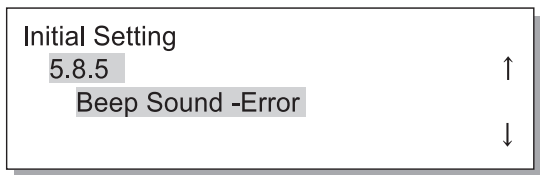
2 Press the  or  key to display "Beep Sound -Error."



3 Press the OK Key.

4 Press the  or  key to select ON or OFF.

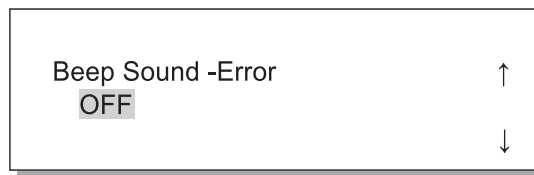



5 Press the OK Key.

When the screen in step 2 reappears, you can continue setting.

To exit the setting, press the PRINT/PAUSE key.



5.8.7 Displayed Language

1 Use steps 1 to 3 of "5.8.1 Sleep" (p.2-48) to display "Initial Setting."

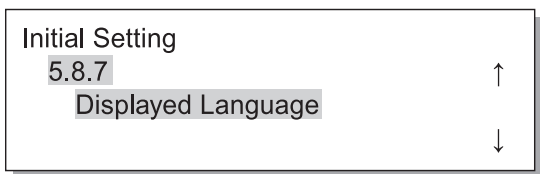
2 Press the  or  key to display "Displayed Language."



3 Press the OK Key.

4 Press the  or  key to select.

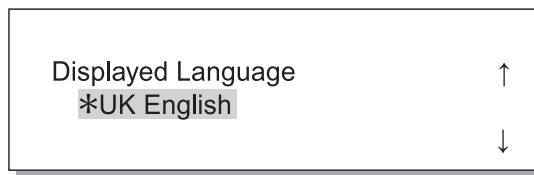

5 Press the OK Key.

When the screen in step 2 reappears, you can continue setting.

To exit the setting, press the PRINT/PAUSE key.



5.8.8 Metric/Inch Switch

1 Use steps 1 to 3 of "5.8.1 Sleep" (p.2-48) to display "Initial Setting."

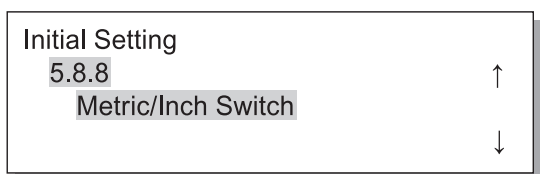
2 Press the  or  key to display "Metric/Inch Switch."



3 Press the OK Key.

4 Press the  or  key to select the unit.



5 Press the OK Key.

When the screen in step 2 reappears, you can continue setting.

To exit the setting, press the PRINT/PAUSE key.



5.8.17 Tray Selection Rule

1 Use steps 1 to 3 of "5.8.1 Sleep" (p.2-48) to display "Initial Setting."

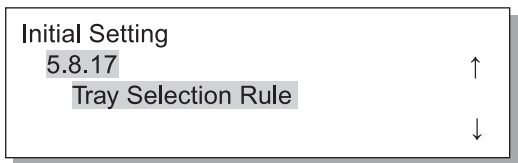
2 Press the  or  key to display "Tray Selection Rule."



3 Press the OK Key.

4 Press the  or  key to select.

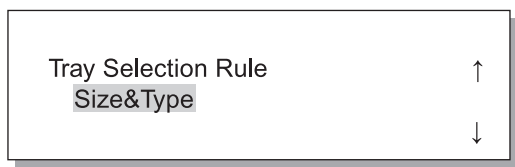

5 Press the OK Key.



When the screen in step 2 reappears, you can continue setting.

To exit the setting, press the PRINT/PAUSE key.

2



5.8.18 Print Mode Auto-ON

1 Use steps 1 to 3 of "5.8.1 Sleep" (p.2-48) to display "Initial Setting."

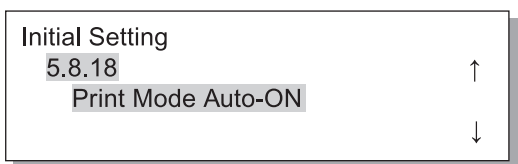
2 Press the  or  key to display "Print Mode Auto-ON."



3 Press the OK Key.

4 Press the  or  key to select ON or OFF.

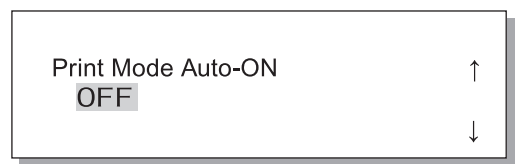

5 Press the OK Key.

When the screen in step 2 reappears, you can continue setting.

To exit the setting, press the PRINT/PAUSE key.



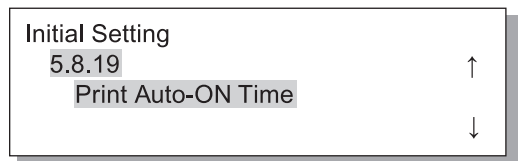

5.8.19 Print Auto-ON Time

1 Use steps 1 to 3 of "5.8.1 Sleep" (p.2-48) to display "Initial Setting."

2 Press the  or  key to display "Print Auto-ON Time."



3 Press the OK Key.

4 Press the   keys to move the cursor, and press the   keys to input the desired time.

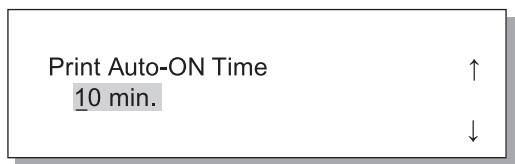



5 Press the OK Key.

When the screen in step 2 reappears, you can continue setting.

To exit the setting, press the PRINT/PAUSE key.

5.8.20 Menu Auto-Shut OFF

1 Use steps 1 to 3 of "5.8.1 Sleep" (p.2-48) to display "Initial Setting."

2 Press the  or  key to display "Menu Auto-Shut OFF."

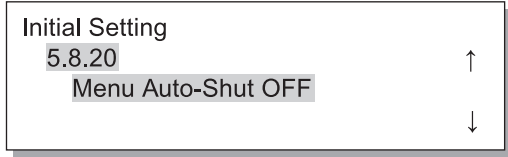

3 Press the OK Key.

4 Press the  or  key to select ON or OFF.



5 Press the OK Key.

When the screen in step 2 reappears, you can continue setting.

To exit the setting, press the PRINT/PAUSE key.



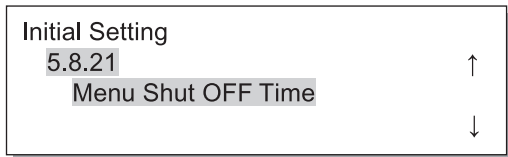

5.8.21 Menu Shut OFF Time

1 Use steps 1 to 3 of "5.8.1 Sleep" (p.2-48) to display "Initial Setting."

2 Press the  or  key to display "Menu shut OFF Time."



3 Press the OK Key.

4 Press the   keys to move the cursor, and press the   keys to input the desired yime.





5 Press the OK Key.

When the screen in step 2 reappears, you can continue setting.

To exit the setting, press the PRINT/PAUSE key.



5.8.22 Stand-by

1 Use steps 1 to 3 of "5.8.1 Sleep" (p.2-48) to display "Initial Setting."

2 Press the  or  key to display "Stand-by."



3 Press the OK Key.

4 Press the  or  key to select ON or OFF.





5 Press the OK Key.

When the screen in step 2 reappears, you can continue setting.

To exit the setting, press the PRINT/PAUSE key.



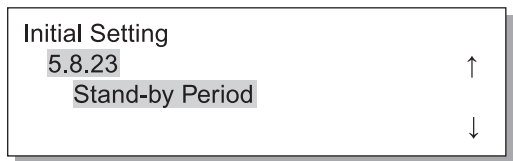

5.8.23 Stand-by Period

1 Use steps 1 to 3 of "5.8.1 Sleep" (p.2-48) to display "Initial Setting."

2 Press the  or  key to display "Stand-by Perid."



3 Press the OK Key.

4 Press the   keys to move the cursor, and press the   keys to input the desired time.

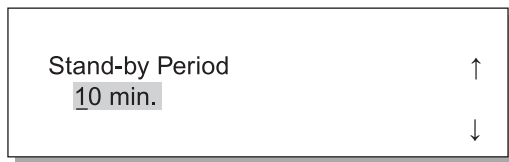

5 Press the OK Key.



When the screen in step 2 reappears, you can continue setting.

To exit the setting, press the PRINT/PAUSE key.

2

5.8.50 Head Recovery

1 Use steps 1 to 3 of "5.8.1 Sleep" (p.2-48) to display "Initial Setting."

2 Press the  or  key to display "Head Recovery."

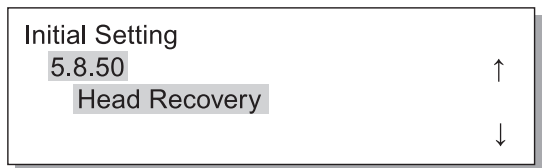

3 Press the OK Key.

4 After checking the message, press the OK Key.

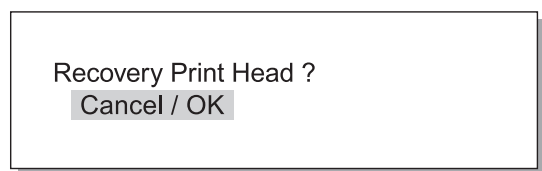

When the message "Cleaning Print Head ?" blinks, cleaning is performed. After cleaning is completed, the screen in step 2 reappears.



To exit the setting, press the PRINT/PAUSE key.

Menu 6 Feed Tray Selection



If the paper conditions of data received from a computer and the setting of "5.8.17 Tray Selection Rule" do not match the conditions of any of the Standard Feed Tray and other feed trays, printing will not start. In this case, you can specify the Standard Feed Tray or another feed tray where the printer paper is set and start printing with no trouble.

① Selectable Feed Trays

| | |
|-----------------------|--|
| Selectable feed trays | Selectable feed trays are shown below. |
| Auto | Normally, set "Auto." A feed tray proper for data from the computer and the setting of "5.8.17 Tray Selection Rule" is automatically selected. |
| Standard Feed Tray | Printed onto paper in the Standard Feed Tray. |
| Feed Tray 1 | Printed onto paper in Feed Tray 1. |
| Feed Tray 2 | Printed onto paper in Feed Tray 2. |

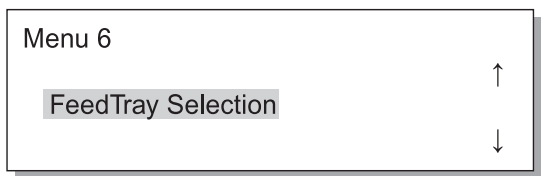
- 1 Press the MENU Key.**
- 2 Press the  or  key to display "Feed Tray Selection."**



- 3 Press the OK Key.**
- 4 Press the  or  key to select the desired feed tray.**

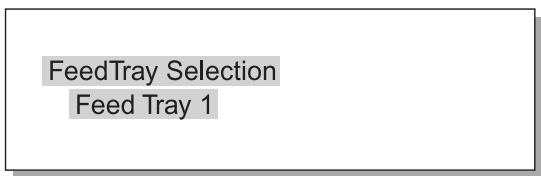

- 5 Press OK Key.**
When the screen in step 2 reappears, you can continue setting.
To exit the setting, press the PRINT/PAUSE key.

Menu 7 Job Clear

Cancels the currently printed job and clears the data.

What is Job?

When data is transmitted from a computer to the printer, the controller processes the data and sends the print data to the FORCEJET™ ENGINE. The processed data is called "Job."
"Job" means the data shown below.

- Data suspended temporarily
- Data for which additional printing is set with the Temporary Data Retrieve function.

2

1 Press the MENU Key.

2 Press the  or  key to display "Job Clear."



3 Press the OK Key.

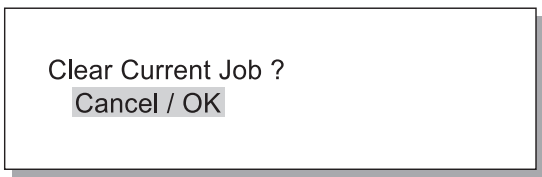

4 Check the message. To clear, press the OK Key.

Message "Executing" is displayed and the data is cleared. If the CANCEL key is pressed, the screen in step 2 appears again.

When the screen in step 2 reappears, you can continue setting.

To exit the setting, press the PRINT/ PAUSE Key.

Chapter3 Troubleshooting

This chapter describes the causes of and measures against trouble indicated with an error message displayed on the Operation Panel or lighting symbol. This chapter also describes how to remove jammed paper and replacing an ink cartridge.



Explanation of Set Error Display

If trouble occurs during printing, printing stops and a symbol lights up on the Operation Panel or an error message appears in the display.

You can check the location based on the symbol or number and see the information from the message in the display.

Symbol Display on Operation Panel

A symbol indicating the relevant portion or type lights up. It may indicate a paper jam or ink cartridge replacement.

Remaining Volume Notice Indicators

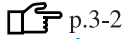

FORCEJET™ Link Symbol

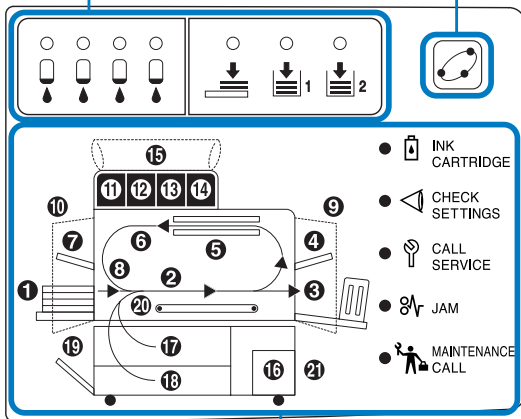
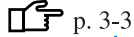

Error indicator

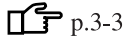

Error Message

A message indicating the detail of the error and the solution appears in the display.

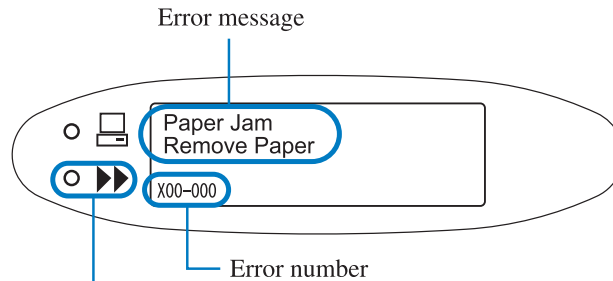

If an error that does not light ● / ● / ● / ● / ● / ● / ● / ● occurs, this indicator lights up and a message is displayed.



If [21] in the panel is lit, an error occurs in the optional Finisher.
 HC Finisher: Refer to "HC Finisher Maintenance Guide".
 HC Auto Stacker: Refer to the following page and subsequent ones in this Guide.

Remaining Volume Notice Indicators

If remaining volume of paper in the Feed Trays (Standard Feed Tray) or when ink is low (approximately 30%), the relevant Remaining Volume Notice Indicator will light up.

After the indicator lights up, printing can be continued. When the ink runs out, the INK CARTRIDGE Indicator and the cartridge number in which the ink runs out will light up which will cause printing to halt. When paper runs out, a message indicating to add paper will appear in the display and will be stopped. If the indicator lights up, prepare ink cartridges or paper for replacement.

"Ink Cartridge Replacement" p.3-18 "Loading Paper" p.1-11

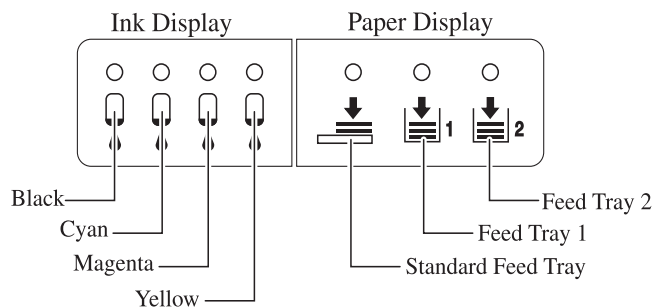

FORCEJET™ Link Symbol

HC5500 Series realizes high speed printing by performing the optimum data processing and colour management with the printer controller and adjusting print speed, paper size, paper quality, and ink quantity totally with the FORCEJET™ ENGINE. The FORCEJET™ Link Symbol indicates whether each printing related section functions properly.

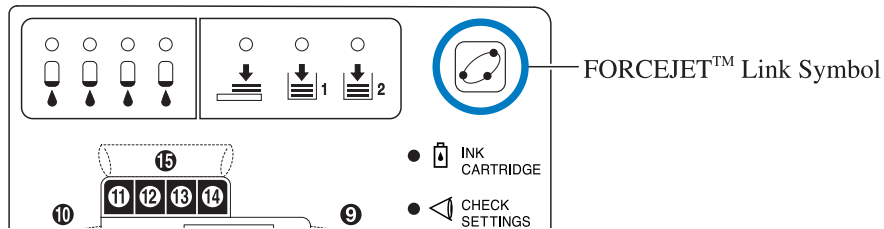

If colour management cannot be performed properly because, for example, an ink cartridge is not set, the FORCEJET™ Link Symbol goes out. At this time, check the status of consumables and settings.

Error Message and Error Number

ⓘ Error Number

Under a message in the display, an error number that consists of alphanumeric characters is displayed. The first letter of the error number indicates the error type.

The number of digits in relation to error number depends on the error location.

| Example of Error Number | Description | |
|-------------------------|----------------------|---|
| S00-000 | System Error | Displayed when inspection or repair by service personnel is required. Contact your local dealer (or service representative). |
| U00-000 | Unit Error | Displayed when repair by service personnel is required. Contact your local dealer (or service representative). You can use the printer except the relevant unit by pressing the Cancel key. |
| X00-000 H00 | Paper Jam | Displayed when a paper jam occurs. |
| X00-000 F00 | Paper Jam | Displayed when consumables or parts to be replaced periodically must be replaced soon. |
| Y00-000 | Consumables Error | Displayed when consumables or parts to be replaced periodically must be replaced soon. |
| Z00-000 | Check Settings Error | Displayed when a cover or anything related is not securely closed. |
| W00-000 | Warning | Various warning messages are displayed. |
| M00-000 | Maintenance Call | Displayed when maintenance of this unit is required. Contact your local dealer (or service representative). |

Y00-000  **Ink Replacement Error**

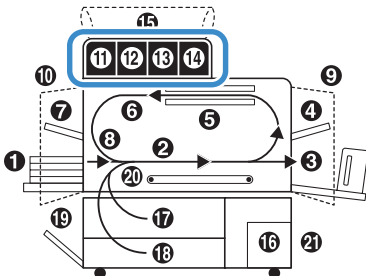
| Lighting location | Message | Solution |
|---|--|--|
|  | <div style="border: 1px solid gray; padding: 5px; width: fit-content;"> <p>No Ink Replace Ink Cartridge</p> </div> | <p>The supply in the ink cartridge runs out. Set a new ink cartridge. ☞ p.3-18</p> |

Z00-000  **Check Settings Error**

If a cover has not been securely closed or in situation of an ink cartridge or Feed Tray which has not been properly set. Check the location, take proper measures, and close the cover.

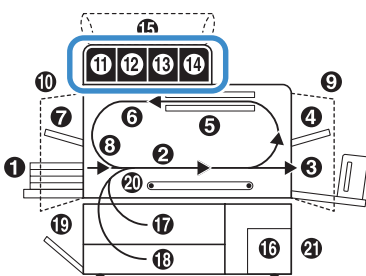
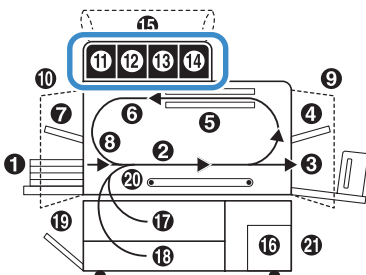
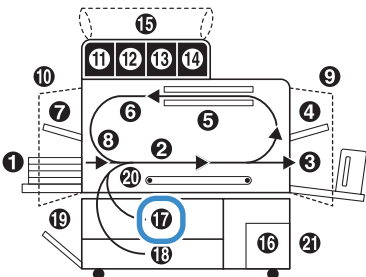
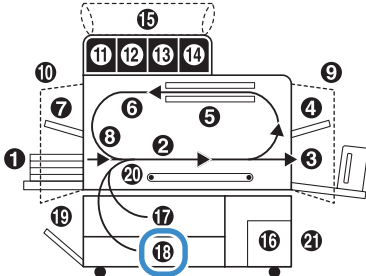
| Lighting location | Message | Solution |
|---|--|---|
|  | <div style="border: 1px solid gray; padding: 5px; width: fit-content;"> <p>No Ink Cartridge Install Ink Cartridge</p> </div> | <p>If an ink cartridge has not been properly set, make sure to check if the cartridges are securely inserted. ☞ p.3-18</p> |
|  | <div style="border: 1px solid gray; padding: 5px; width: fit-content;"> <p>Ink Cartridge Error Check Ink Cartridge</p> </div> | <p>If the colour of an ink cartridge is not correct or a cartridge with a different shape has been set, make sure to check the location and reset the cartridge. ☞ p.3-18</p> |
|  | <div style="border: 1px solid gray; padding: 5px; width: fit-content;"> <p>Feed Tray 1 is Open Check Feed Tray 1</p> </div> | <p>If Feed Tray 1 has not been securely closed, be sure to securely close it.</p> |
|  | <div style="border: 1px solid gray; padding: 5px; width: fit-content;"> <p>Feed Tray 2 is Open Check Feed Tray 2</p> </div> | <p>If Feed Tray 2 has not been securely closed, be sure to securely close it.</p> |

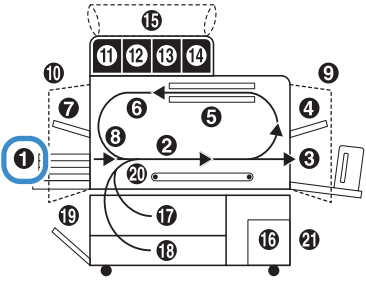
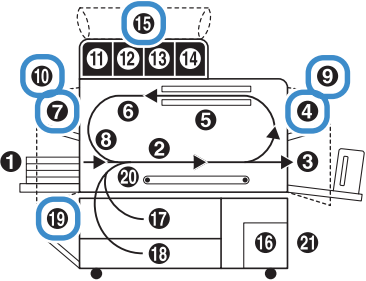
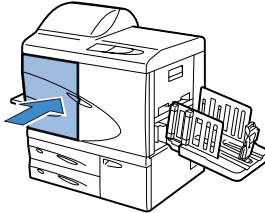
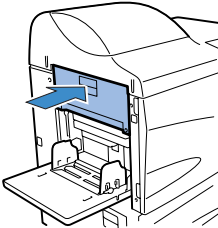
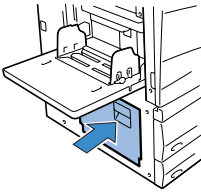
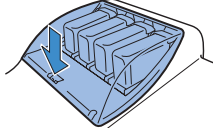
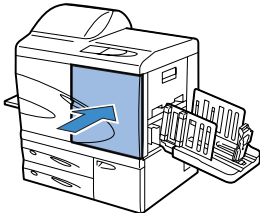
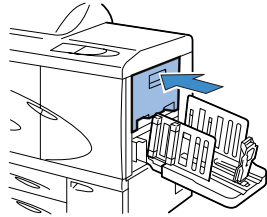
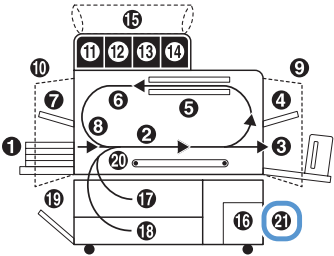
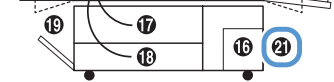
| Lighting location | Message | Solution |
|---|---|---|
|  | <p>Standard Tray Error Check Standard Tray</p> | <p>If Standard Feed Tray has not been properly opened, open the Standard Feed Tray properly.</p> |
|  | <p>Cover is Open Close the Cover</p> | <p>If a cover has not been securely closed, make sure to check the location indicated by an indicator and close the cover securely.</p> |
| | <p>⑩ Front Cover (left)</p>  <p>⑦ Left Transfer Path Cover</p>  <p>⑱ Transfer Section Door</p>  | <p>⑮ Ink Cover</p>  <p>⑨ Front Cover (right)</p>  <p>④ Right Transfer Path Cover</p>  |
|  | <p>!Finisher Error! Set Finisher Unit in Place</p> | <p>HC Auto Stacker is not in place. Be sure to attach it to the printer.</p> |
|  | <p>!Finisher Error! Close the Cover</p> | <p>Jam Release Cover has not been securely closed, be sure to close it.</p> |

S00-000  System Error

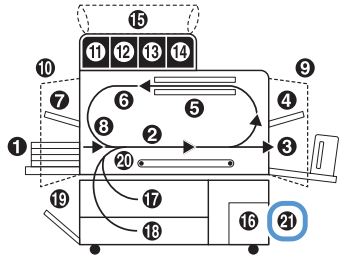
| Lighting location | Message | Solution |
|---|--|---|
| (Nothing is lit.) | !System Error! Restart Printer or Call Service | An error occurs in the printer. If the same message appears even when the power is turned off and then on again, contact your local dealer (or service representative). At this time, report also the error number indicated in the Message Display. |
|  | !Finisher Error! Restart Printer or Call Service | <p>☞ p.3-3</p> |
| | !System Error! Restart Printer or Call Service | |

X00-000 H00  Paper Jam Error

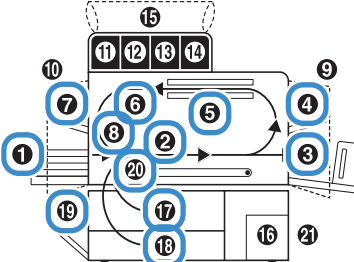
| Lighting location | Message | Solution |
|--|-----------------------------------|---|
|  | Paper Jam Remove Paper | <p>If there's a paper jam in the printer, paper mis-feed or paper double feed occurs, be sure to check the location indicated by the indicator and remove the paper.</p> <p>☞ p.3-9</p> |
| | Paper Mis-feed Remove Paper | |
| | Paper Double Feed Remove Paper | |

X00-000 F00  Paper Jam Error



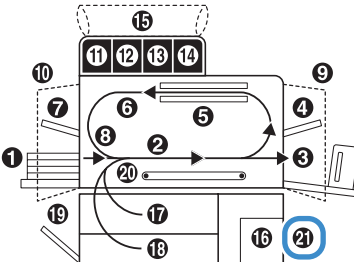

This indication is displayed only if an optional Finisher is connected.

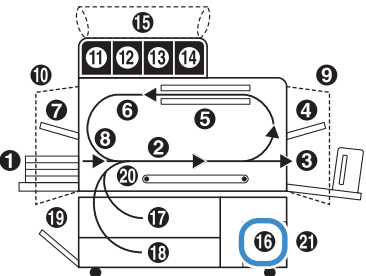
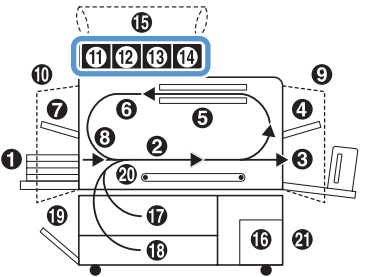
| Lighting location | Message | Solution |
|---|---------------------------|---|
|  | Paper Jam Remove Paper | <p>A paper jam occurs in the optional Finisher. Check the indicated jam location and remove the paper.</p> <p>For details, HC Finisher: Refer to "HC Finisher Maintenance Guide". HC Auto Stacker: Refer to the ☞ p.3-17 in this Guide.</p> |

| Lighting location | Message | Solution |
|--|--|--|
|  | <p>Time to Replace Ink Drain Tank</p> | <p>The Ink Drain Tank is almost full. Contact your local dealer (or service representative).</p> |
| <p>(Nothing is lit.)</p> | <p>(No message.)</p> | <p>When the Maintenance Call Indicator lights up, periodical maintenance is required. Contact your local dealer (or service representative).</p> |
| <p>(Nothing is lit.)</p> | <p>Requiring Update of Ink Information</p> | <p>No colour profile corresponding to the installed ink is provided. Contact your dealer (or service representative).</p> |
|  | <p>Check Ink Cartridge</p> | <p>When the Maintenance Call Indicator lights up and the message left is displayed, contact your dealer (or service representative).</p> |

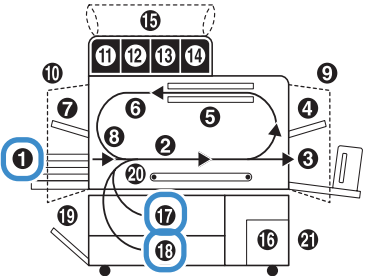
W00-000  Warning

| Lighting location | Message | Solution |
|---|--|--|
|  | <p>No Paper Load Paper in Tray</p> | <p>If paper or separation paper runs out, be sure to load more paper. "Loading Paper"  p.1-11</p> |
| | <p>No Paper Load Paper in Interposer Tray</p> | <p>Paper in the Interposer Tray has run out or paper that matches the size specified from the printer driver is not loaded. Load the paper.</p> |
| | <p>Paper Size Mismatch Load Paper in Interposer Tray</p> | |

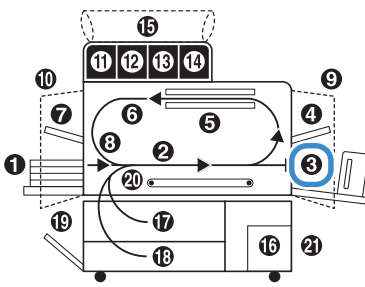
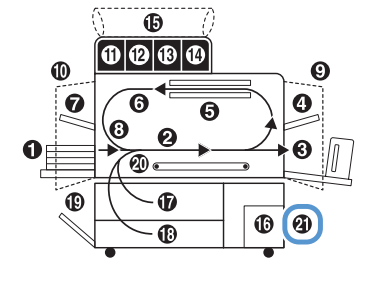
| Lighting location | Message | Solution |
|---|---|---|
|  | <div data-bbox="576 144 948 272" style="border: 1px solid gray; padding: 5px;">Check Stacking Tray</div> | <p>If the guides in the Auto Stacking Tray are not properly set, make sure to check the Auto Stacking Tray.</p> |
|  | <div data-bbox="576 463 948 591" style="border: 1px solid gray; padding: 5px;">!Finisher Error! Open Cover Check Paper</div> <div data-bbox="576 634 948 761" style="border: 1px solid gray; padding: 5px;">Paper Overloaded Remove Paper in Paper Receiving Tray</div> <div data-bbox="576 804 948 932" style="border: 1px solid gray; padding: 5px;">Check Paper Receiving Tray Remove Postcard</div> | <p>Paper is jammed in the HC Auto Stacker. Open the Jam Release Cover to remove paper. Press the Cancel Key on the printer after removing jammed paper. p.3-17</p> <p>Paper ejected onto the Shift Tray of the HC Auto Stacker exceeded the capacity of the tray. Remove paper from the Shift Tray. Open the Jam Release Cover once and then press the Cancel Key on the printer.</p> |
| (Nothing is lit.) | <div data-bbox="576 974 948 1102" style="border: 1px solid gray; padding: 5px;">No Volume Remains in Controller HDD</div> | <p>The hard disk in the controller section is full. Check the data in the hard disk (such as storage data) and delete unnecessary jobs.</p> |
| (Nothing is lit.) | <div data-bbox="576 1144 948 1272" style="border: 1px solid gray; padding: 5px;">Execute Print Head Cleaning</div> | <p>The system requires cleaning. Carry out the normal cleaning.</p> |
| (Nothing is lit.) | <div data-bbox="576 1315 948 1442" style="border: 1px solid gray; padding: 5px;">Paper Size Mismatch Load Specified Paper in Tray</div> <div data-bbox="576 1485 948 1613" style="border: 1px solid gray; padding: 5px;">Paper Type Mismatch Load Specified Paper in Tray</div> | <p>There is no paper in any of the Feed Trays and the Standard Paper Feed Tray that corresponds to the paper size and type specified from the printer driver. After loading paper, specify the relevant Feed Tray using "Menu 6 Feed Tray Selection" from the Operation Panel of the printer. "Although paper is set, "No Paper" error can occur." p.3-22</p> |
| (Nothing is lit.) | <div data-bbox="576 1655 948 1783" style="border: 1px solid gray; padding: 5px;">Envelope Error Change settings or Clear Current Job</div> | <p>With "Paper Feed Control," "Envelope" is set for the tray to which duplex printing or facedown output is specified by the printer driver. Change the setting of Paper Feed Control or the printer driver. "Menu 6 Feed Tray Selection" p.2-54 "4.1.2 Paper Type" p.2-20</p> |
| (Nothing is lit.) | <div data-bbox="576 1868 948 1996" style="border: 1px solid gray; padding: 5px;">Duplex Size Error Originals invalid Clear Current Job</div> | <p>For duplex printing, different paper sizes are set for the front page and the back page. Set the same size for both the front and back pages.</p> |

Paper jam occurs

If a paper jam occurs in the printer or paper is not fed, printing stops, the **JAM** indicator, and the number indicating the jam location will light up. In this case, remove the jammed paper and press the **PRINT/PAUSE** Key, printing will resume. Since this unit performs high speed printing, paper jams may occur at multiple locations. In this case, remove all the jammed paper.

 If an optional HC Finisher is connected and a paper jam occurs in the HC Finisher (21 on the Operation Panel is lit), refer to "HC Finisher Maintenance Guide."

 When removing jammed paper, take care not to leave pieces of paper inside the printer.

Paper Jam Location

Details of the indicated locations are shown below. For detailed procedure, refer to the respective indicated page.

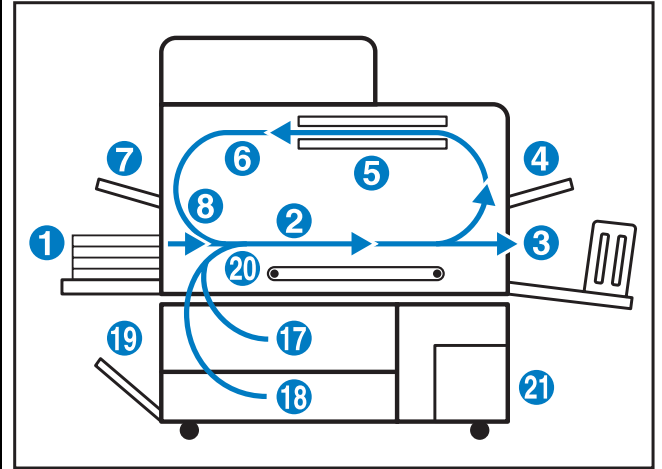
|  | Jam location | Page referred to |
|--|-------------------------------------|------------------|
| | (1) Standard Paper Feed Tray | p.3-9 |
| | (2) On Transfer Roller | p.3-10 |
| | (3) Paper Receiving Section | p.3-10 |
| | (4) Right of Transfer Unit | p.3-11 |
| | (5) Duplex Transfer Unit | p.3-12 |
| | (6)(7)(8) Left of Transfer Unit | p.3-14 |
| | (17)(18)(19) Paper Feed Tray 1 or 2 | p.3-15 |
| | (20) Transfer Unit | p.3-16 |
| | (21) HC Auto Stacker | p.3-17 |

(1) Paper Jam in the Standard Paper Feed Tray

1 While pressing the Paper Release Lever on the paper feed side to the left, remove the paper.

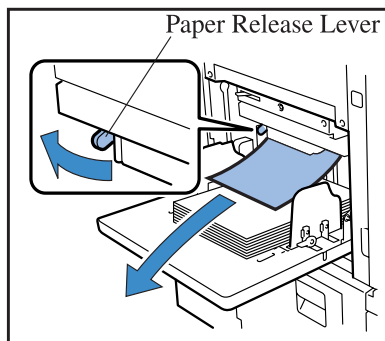

2 Press the **CANCEL/ BACK** Key.

The paper jam error is cleared.

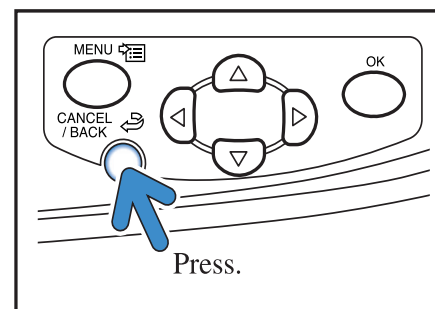

(2) Paper Jam on the Transfer Roller

1 Open the Front Cover.

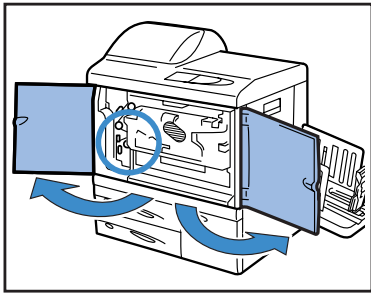

2 Turn Dial A and remove the paper from the Transfer Roller side.

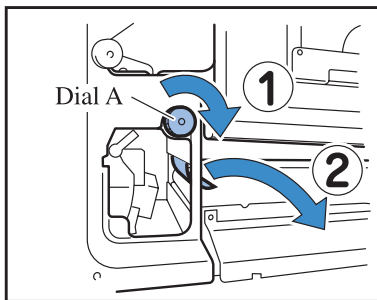

3 Close the Front Cover.

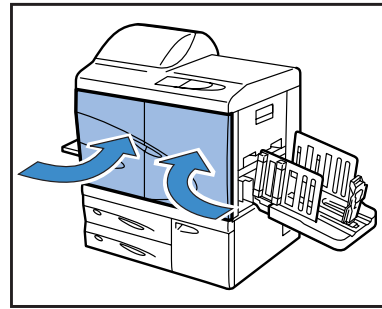

(3) Paper Jam in the Paper Receiving Section

1 Pull out the jammed paper and remove it.

Pull out the jammed paper from the side of the Paper Receiving Tray.

- ⚠ If it is not easy to pull out, do not pull it forcibly because the paper might be torn. Open the Front Cover and remove the paper from the side of the Transfer Roller.

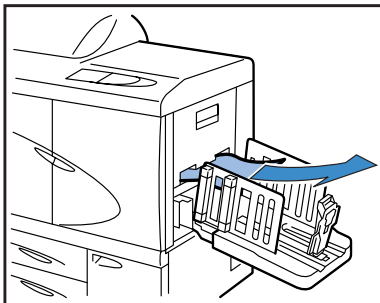

(4) Paper Jam in the Right of the Transfer Unit

- 1** Open the Right Transfer Path Cover.

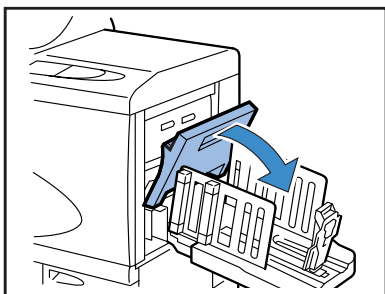

- 2** Remove the paper.

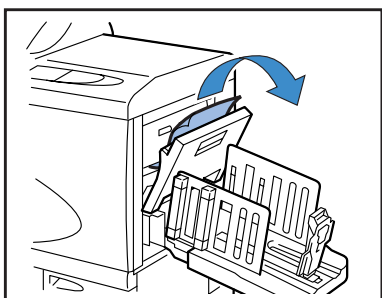

- 3** Close the Right Transfer Path Cover.

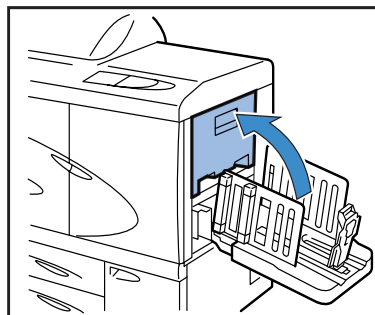

3

When the HC Auto Stacker is connected.

- 1** While pressing the Release Lever, pull the Auto Stacker to the side.

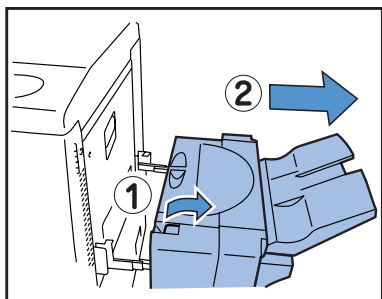

- 2** Open the Right Transfer Path Cover.

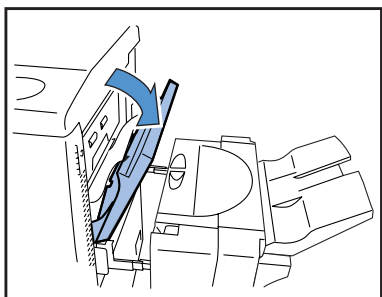

- 3** Remove the jammed paper.

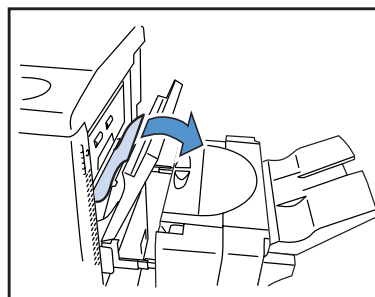

- 4** Close the Right Transfer Path Cover.

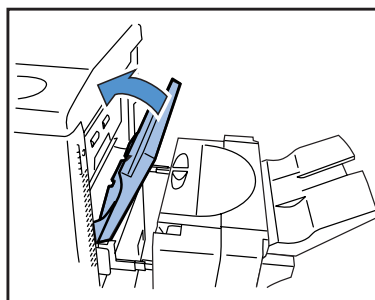

- 5** Return the Auto Stacker to its original position.

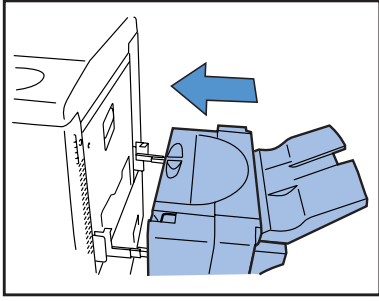

(5) Paper Jam in the Duplex Transfer Unit

- 1** Open the Front Cover.

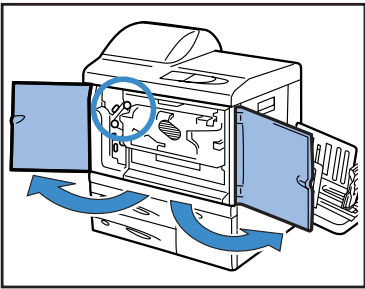

- 2** Lift the tab at the left side of the Reversing Path Cover and lock it.

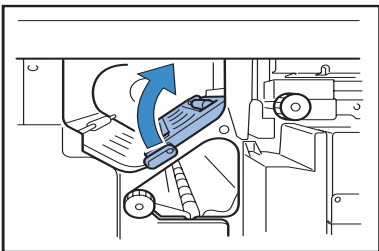

- 3** Turn Dial B.

If the paper is removed, proceed to step 7.

- !** Turn Dial B several times to check to see if any paper remains. Multiple sheets of paper may have jammed. Turn the dial repeatedly until no paper can be removed.

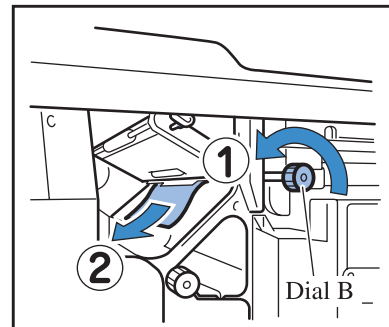

- 4** Pull out the Duplex Transfer Unit.

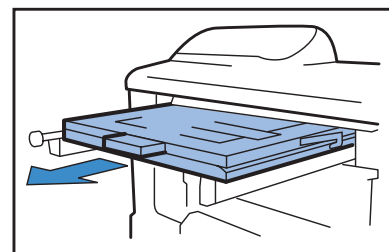

5 Open the unit and check inside.

If paper remains, remove it.

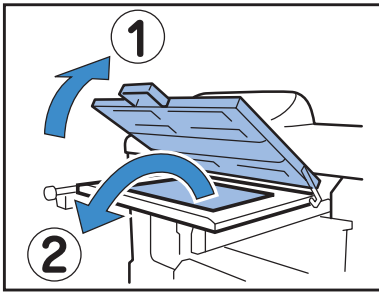

6 Return the Duplex Transfer Unit to its original position.

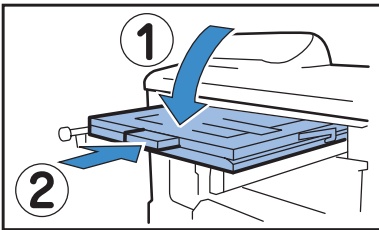

7 Return the tab at the left of the Reversing Path Cover to its original position.

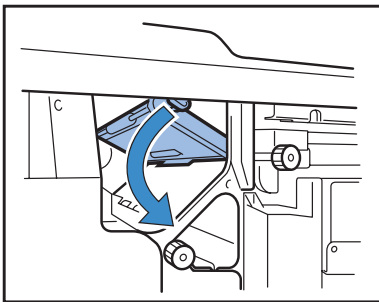

8 Close the Front Cover.

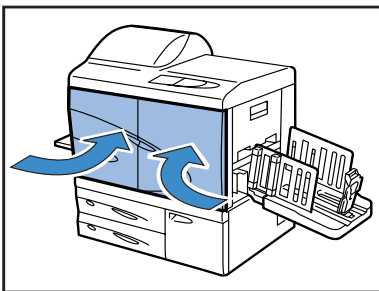

(6)(7)(8) Paper Jam in the Left of the Transfer Unit

- 1** Open the Front Cover.

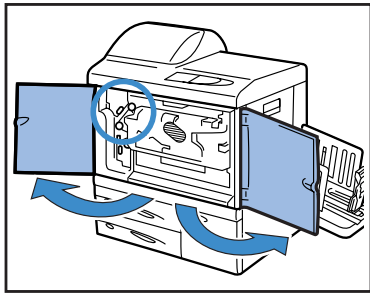

- 2** Lift the tab at the left side of the Reversing Path Cover and lock it.

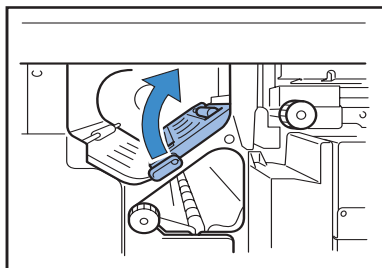

- 3** While turning Dial B in the direction indicated by the arrow, remove the paper.

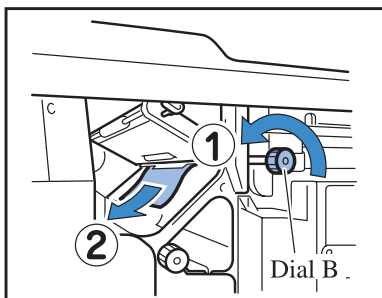

- 4** If the paper cannot be removed, open the Left Transfer Path Cover and remove the paper.

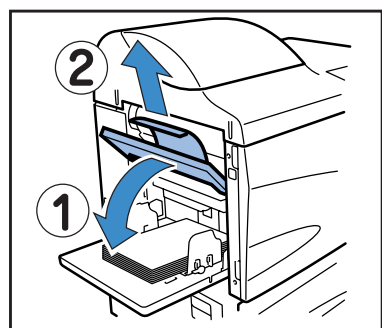

- 5** If the paper cannot be removed, while turning Dial C in the direction indicated by the arrow, remove the paper.

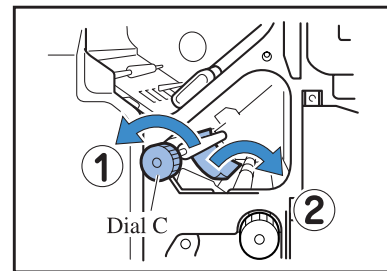

- 6** Return the tab at the left of the Reversing Path Cover to its original position.

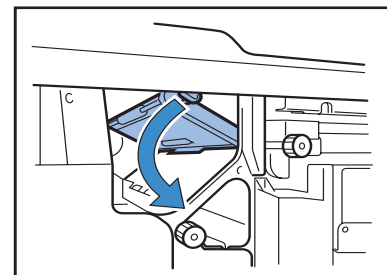

- 7** Close the Front Cover.

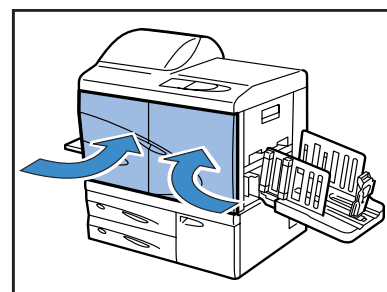

(17)(18)(19) Paper Jam in Paper Feed Tray 1/ Paper Feed Tray 2

- 1 Pull out the Feed Tray.

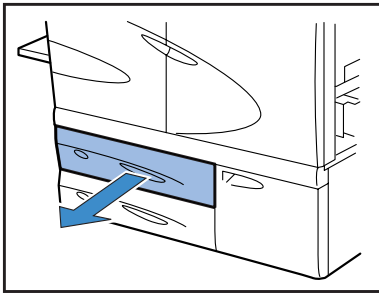

- 2 Remove the jammed paper.

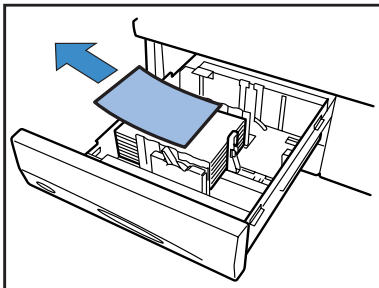

- 3 If the paper cannot be removed, open the Transfer section door at the left side of the Feed Tray and remove the paper.

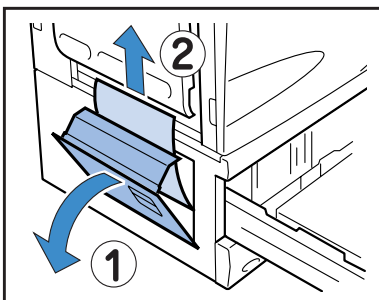

- 4 Close the door and return the Feed Tray.

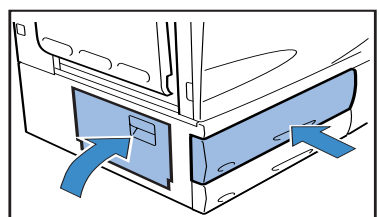

(20) Paper Jam in the Transfer Unit

- 1 Open the Front Cover.

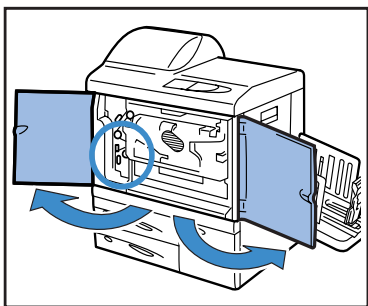

- 2 Turn the Transfer Lock Lever to the left and turn down the tab to the right.

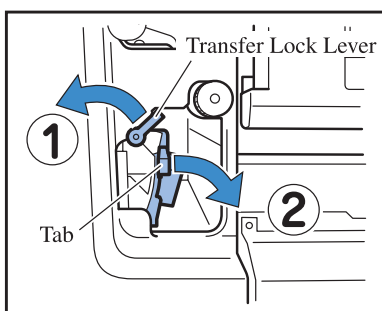

- 3 Remove the jammed paper.

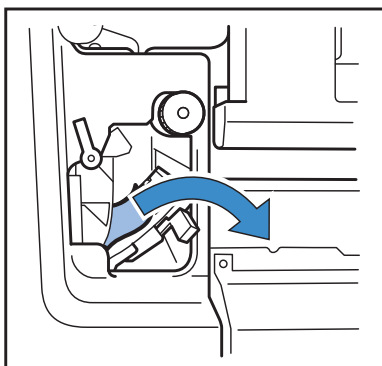

- 4 Return the tab to its original position and turn the Transfer Lock Lever to the right.

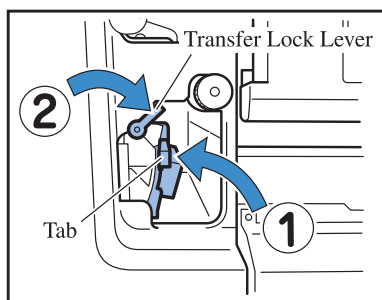

- 5 Close the Front Cover.

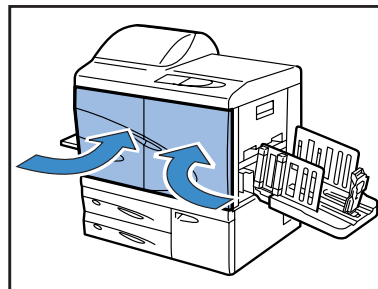

(21) Paper Jam in HC Auto Stacker (option)

- 1 Open the Jam Release Cover.

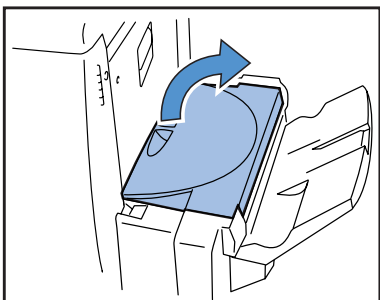

- 2 Remove the jammed paper.

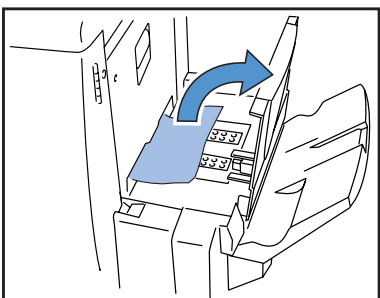

- 3 Close the Jam Release Cover.

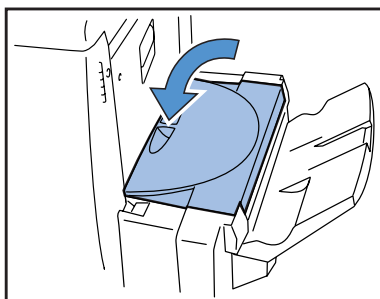

Ink Cartridge Replacement

If ink runs out, the  INK CARTRIDGE indicator and the indicator that shows the location of the empty cartridge will light up, printing will be halted. Be sure to check the colour of the Ink Cartridge and replace it.

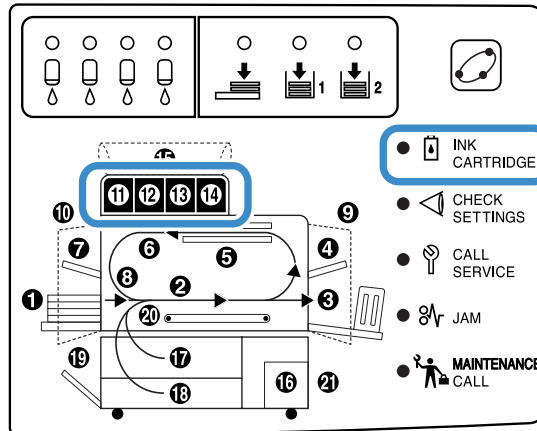

- ① Black (K)
- ② Cyan (C)
- ③ Magenta (M)
- ④ Yellow (Y)

Ink Cartridge

This section describes the notes in handling an Ink Cartridge. Handling of Ink Cartridge is also described in "Safety Precautions" (p.v) and "Before Starting to Use" (p.vii, p.viii). Read also the description on these pages.

CAUTION

Ink may be stuck to the ink feed opening. Be careful not to touch it with your hands or clothes. If your hands are stained with the ink, wash it off immediately with a detergent. If ink gets into your eyes, flush it out immediately with plenty of water.



- Be sure to use dedicated ink specified by our company. Otherwise, a failure or trouble might occur.
- Do not remove the Ink Cartridge until the INK CARTRIDGE indicator lights up.
- Do not shake or drop the Ink Cartridge.
- Do not keep the Ink Cartridge with its nozzle downward.
- When replacing an ink cartridge, do not leave the printer with an ink cartridge removed. A failure might occur.
- Do not shake the Ink Cartridge. If the cartridge is shaken, air bubbles are generated and ink may not be discharged properly, resulting in blurred printing.
- Do not remove the caps(white) from the ink feed opening and the air intake.

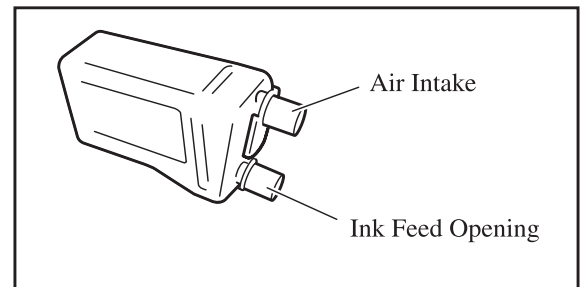

- Do not add ink into the Ink Cartridge.
- Use as soon as possible after purchase to maintain optimum print quality.

<Used Ink Cartridge>

- Do not release the ink left in the cartridge into a sewer or personal disposal unit.
- Used Ink Cartridges are collected by a service representative. After use is complete, attach the cap and put the cartridge into the inner bag and packing material.
When attaching the cap or packing, be sure to hold the Ink Cartridge with the cap up. Caution : Do not turn the Ink Cartridge upside down.

As an example, procedure for replacing the Yellow (Y) Ink Cartridge ((14) is light) is described.

1 Open the Ink Cover.

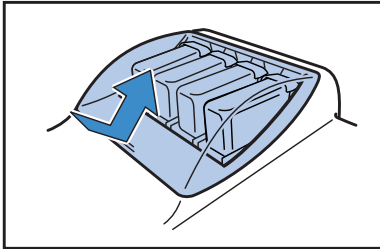

2 While lifting the Ink Cartridge to be replaced, pull it toward the front side and remove it.

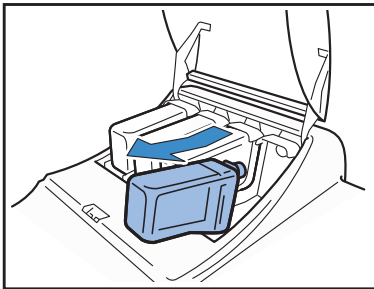

3 Remove the cap from the new Ink Cartridge.

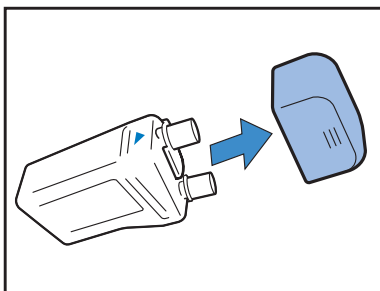

4 Hold the surface of the Ink Cartridge with the ▲ mark up and insert the cartridge until it stops.

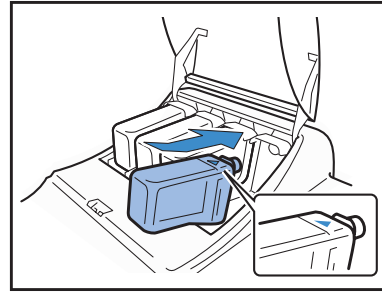

5 Close the Ink Cover.

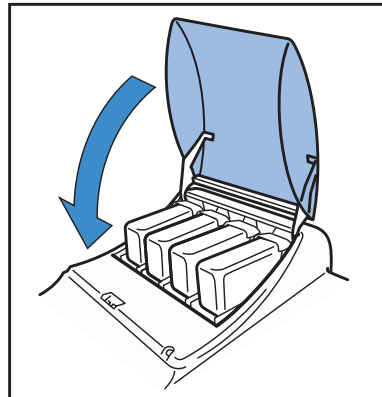

The printer does not operate.

| Problem | Cause and Solution |
|--|---|
| Even if the power is turned on, nothing appears on the Operation Panel. | Be sure to check the following. <ul style="list-style-type: none">• If the power plug is inserted into the outlet.• If the power cord is securely connected to the unit.• If the circuit breaker of the mains is disconnected.• If the main power switch is turned on. If not, turn on the main power switch and then press the Power Key on the Operation Panel. |
| Test print is normally output but data from a computer cannot be properly printed. | Make sure to check the network setting and the IP address setting before installing the printer driver again. <ul style="list-style-type: none">• If a file of the programme or application software seems not normal, print from another file or other application software. If printing from certain file or application software is impossible, be sure to check the print setting of the application software.• Use the printer driver of the latest version. For the latest version, contact your local dealer or service representative. |

In addition, try the following operation. If the printer does not operate even after this operation, contact your local dealer or our company.

- Turn off the printer and then on again.
- Restart the computer that is connected to the printer.

The printer does not operate according to the setting.





| Problem | Cause and Solution |
|--|---|
| "Job separation" is set in the printer driver screen but job separation cannot be performed. | <p>"Separation Paper" is set to "OFF" in the menu setting. If "5.3 Separation Paper" of the menu setting is set to "OFF," job separation paper is not inserted. (If "OFF" is set, printing stops for a few seconds at the time of separation.)</p> <p>To insert job separation paper, select the desired tray at "5.3 Separation Paper" of the menu setting.</p> <p>"4.6 Job Separation" p.2-23 "5.3 Separation Paper" p.2-36</p> |
| Unable to print onto paper in the Standard Feed Tray. | <p>The Standard Feed Tray is not set as a tray for "Auto tray selection." Set "4.5 Triple-Tray Source" of the menu setting.</p> <p>"4.5 Triple-Tray Source" p.2-22 Alternatively, set "6 Feed Tray Selection" of the menu setting to "Standard Feed Tray." "Menu 6 Feed Tray Selection" p.2-54</p> |

3

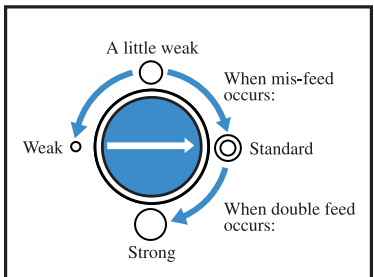
Printing is not clean.

| Problem | Cause and Solution |
|------------------------------------|---|
| Printed image is light or blurred. | <p><u>Type of paper loaded for a Feed Tray (or the Standard Feed Tray) is not correct.</u> Load the correct paper type at [Paper Type] of the menu setting.</p> |
| | <p><u>Print density setting is light.</u> In the printer driver screen or the printer menu setting, set darker print density. "Prinr density" of "HC5500 User's Manual for Printer Driver" p.2-24 When setting in the printer menu setting: p.2-24</p> |
| | <p><u>The print head is clogged.</u> Perform "Normal Cleaning" from the menu setting. If the problem cannot be solved with the method above, specify particularly the head of a lighter colour and perform "Hyper-Cleaning." "5.5 Head Maintenance" p.2-40</p> |
| Printed image is too dark. | <p><u>Type of paper loaded for a Feed Tray (or Standard Feed Tray) is not correct.</u> Load the correct paper type at [Paper Type] of the menu setting.</p> |
| White stripes appear on images. | <p><u>The print head is clogged.</u> First, perform "Normal Cleaning" from the menu setting. If the problem cannot be solved even if normal cleaning is performed several times, perform "Head Recovery." "5.5 Head Maintenance" p.2-40 "5.8.50 Head Recovery" p.2-53</p> |
| Paper is stained. | <p><u>Paper that cannot be used is loaded.</u> Check the paper types that can be loaded in the Standard Feed Tray and the other Feed Trays. "Usable Paper" p.1-7</p> |
| Edge of paper is stained. | <p><u>Curled paper is used.</u> The curled portion hits the print head and is stained. Since the print head may be damaged, do not use curled paper. <u>Performing duplex printing</u> Note that the edges of paper may be stained depending on the original.</p> |

| Problem | Cause and Solution |
|--|--|
| Print speed is too low. | <p><u>The guides in the Standard Feed Tray (Feed Tray) do not fit the paper width.</u> The paper size is judged based upon the guide positions, and print speed depends on specifications of paper size. Adjust the stack guides securely to the width of the paper.</p> |
| A paper jam occurs each time printing is performed. | <p><u>Too much paper is loaded in the Standard Feed Tray or other Feed Trays.</u> When the maximum number of sheets of paper that can be loaded in the Standard Feed Tray or other Feed Trays is exceeded for the number of paper that can be loaded. Please refer to "Loading Paper" p.1-11.</p> |
| | <p><u>Paper is not loaded properly.</u> Check the Stack Guide positions. For proper paper loading, refer to "Loading Paper" p.1-11.</p> |
| | <p><u>Paper that cannot be used is loaded.</u> Check the paper types that can be loaded in the Standard Feed Tray and the other Feed Trays. Do not use particularly wrinkled or curled paper because it may cause a paper jam. "Usable Paper" p.1-7</p> |
| | <p><u>Non-standard size paper is used.</u> When loading non-standard size paper, you must register the size at "5.1 Paper Size Entry" and "5.2 Paper Type Entry" of the menu setting in advance. "5.1 Paper Size Entry" p.2-32 "5.2 Paper Type Entry" p.2-33</p> |
| <ul style="list-style-type: none"> • There's too much paper powder. • Double feed occurs. • Thick paper such as postcard is mis-fed. • The back surface of thick paper such as postcard is peeled off. | <p><u>The paper stripper pressure is not properly adjusted.</u> Use a coin to turn the Paper Stripper Dial located in the paper feed side to adjust the pressure.</p> <p> Before starting adjustment, be sure to remove the paper from the Standard Feed Tray and check that the tray lowers to the lowermost position.</p> <ul style="list-style-type: none"> • If there's too much paper powder, paper is mis-fed or the back side of postcard curls up, turn the dial counterclockwise. • If double feed occurs, turn the dial clockwise. <div data-bbox="1133 1212 1508 1489" style="border: 1px solid black; padding: 5px; text-align: center;">  </div> |
| Paper is not fed at all. | <p><u>The Paper Feed Pressure Adjustment Lever does not fit the paper thickness.</u> When using thick paper, set the Paper Feed Pressure Adjustment Lever to the "✂ (CARD)" position. When printing onto paper other than thick paper, set the lever to the "✂ (NORMAL)" position. If paper mis-feed occurs frequently, however, set the lever to the "✂ (CARD)" position. "Paper Feed Pressure in Standard Paper Feed Tray" p.1-14</p> |
| | <p><u>Paper feed control is not proper.</u> Change the paper feed control set in the Standard Feed Tray or other Feed Trays at "5.2 Paper Type Entry" of the menu setting. "5.2 Paper Type Entry" p.2-33</p> |

| Problem | Cause and Solution |
|---|--|
| <p>Although paper is set, "No Paper" error can occur.</p> | <p><u>[Paper size] and [Paper type] set in the printer driver screen do not match those in the menu setting on the printer.</u></p> <p>Even if proper paper is loaded in the feed tray, if the settings of "Paper Size" and "Paper Type" of the menu setting on the printer are not correct, "No Paper" error occurs. Set the conditions of the feed tray according to the paper in the feed tray. Alternatively, a condition is set at "Tray selection Rule." Ensure that the paper placed in the tray matches the condition of the tray setting.</p> <p>"Configuration 4.1/4.2/4.3"  p.2-19</p> <p>"5.8.17 Tray Selection Rule"  p.2-51</p> <p>Press the Cancel/Back key to display the output paper size at the lower left of the operation panel. Check the size and set paper of the correct size or specify the proper tray from the operation panel of the printer to perform printing. If you specify the Feed Tray on the Operation Panel of the printer, printing can be performed.</p> <p>"Menu 6 Feed Tray Selection"  p.2-54</p> |
| | <p><u>The selected tray is set for "Separation Paper."</u></p> <p>Set "5.3 Separation Paper" of the menu setting to "OFF."</p> <p>"5.3 Separation Paper"  p.2-36</p> |
| | <p><u>The Standard Feed Tray is not a feed tray for auto feed tray selection.</u></p> <p>If "4.5 Triple-Tray Source" is set to "ON", the Standard Feed Tray is included into feed trays for selection when "Auto feed tray selection" is selected in "Paper feed tray" of the printer driver.</p> <p>"4.5 Triple-Tray Source"  p.2-22</p> |

Chapter4 Appendix

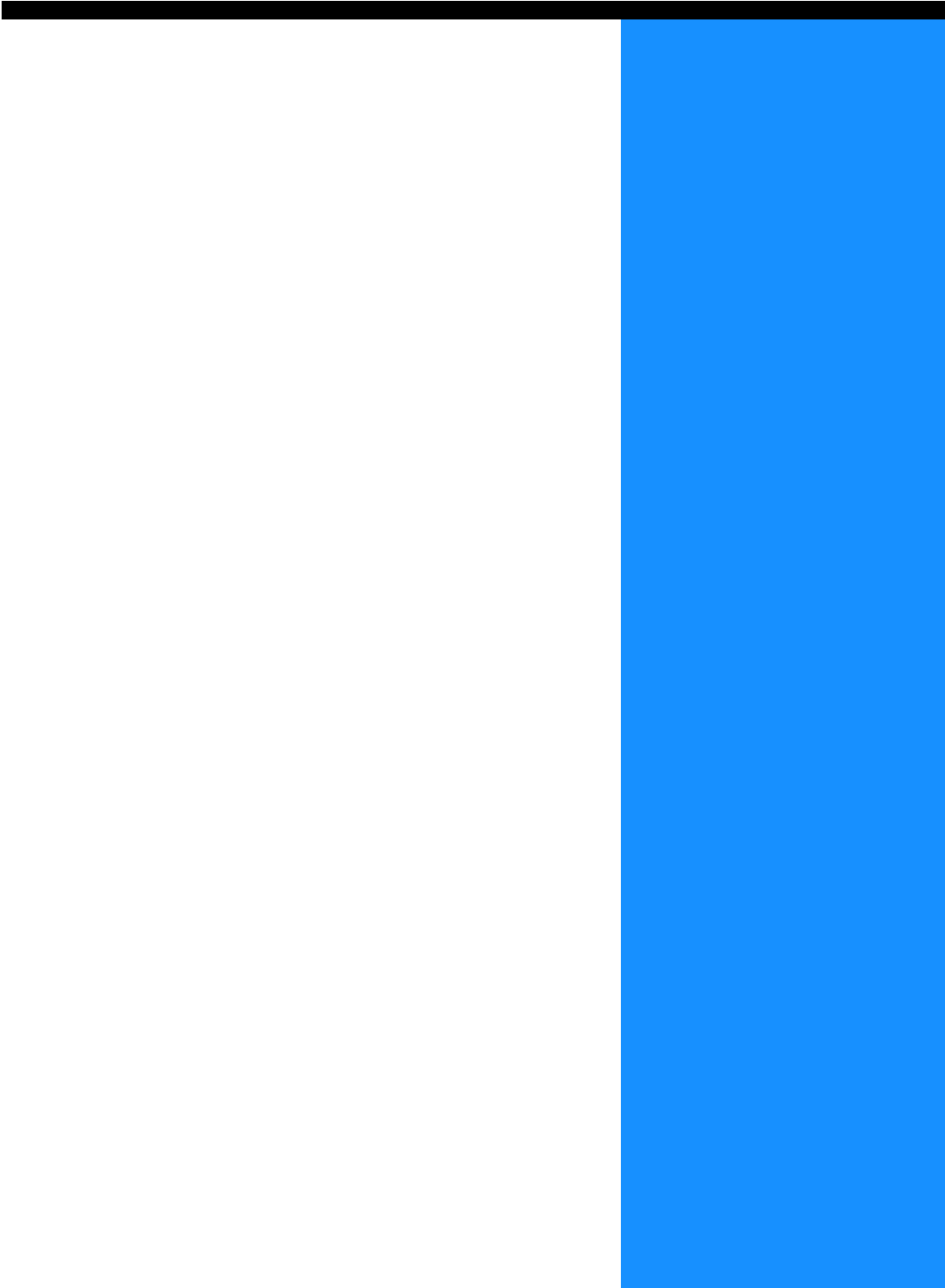

List of Options

A variety of options are available for convenient use of this unit. For purchase, contact your dealer (or service representative) for inquiry.

RISO Scanner HS2000

By connecting a scanner and a display monitor (products specified by our company), you can perform high-speed full-colour printer copies.

Finisher Functions

By connecting an HC Finisher to this machine, you can perform automatically postprocessing of printing such as stapling, punching, booklet creation at a high speed.

HC Auto Stacker

This device provides only “Offset” position ejection at each set. But it is smaller and simpler than HC Finisher.

Consumables

- Note that specifications and types of consumables are subject to change without prior notice.
- For the price, contact your local dealer (or service representative) for inquiry.

Ink Cartridge



Use ink cartridges specifications as directed by our company. Do not use other products because use of improper consumables may cause a failure or trouble.

| Colour | Quantity | Unit |
|---------------------|--------------|---------|
| RISO HC Ink Cyan | NET. 1,000ml | 1 piece |
| RISO HC Ink Magenta | | |
| RISO HC Ink Yellow | | |
| RISO HC Ink Black | | |

Specifications

● Main Body

| | |
|------------------------------------|---|
| Print Type | Line Type Ink Jet System |
| Resolution | Normal: 600 dpi or equivalent Fine: 900 dpi or equivalent (Line Smoothing: ON) |
| Print Head | Piezo type, Physical Resolution 300 dpi, 8 Gradation |
| Ink | Oil-based pigment type, Cyan/Magenta/Yellow/Black, 1,000ml for each |
| Print Speed (*1) | 120 ppm, Duplex 48 ppm (A4, Landscape, Normal mode) |
| Duplex Printing | Standard |
| Printer Collate | Standard |
| Paper Size | Paper Feed Tray: Max. A3 (297mm × 432mm)/Ledger(11" × 17") Min. 182mm × 182mm (7 ³ / ₁₆ " × 7 ³ / ₁₆ "") Standard Paper Feed Tray: Max. 340mm × 550mm (13 ³ / ₈ " × 21 ⁵ / ₈ "") Min. 90mm × 148mm (3 ⁹ / ₁₆ " × 5 ¹³ / ₁₆ "") |
| Paper Weight | Paper Feed Tray: 52g/m ² to 104g/m ² (14-lb bond to 28-lb bond) paper Standard Paper Feed Tray: 46g/m ² to 210g/m ² (12-lb bond to 56-lb bond) paper |
| Printable Area | Max. 314mm × 458mm (12 ³ / ₈ " × 18 ⁵ / ₁₆ "") (margin width of 1mm (0.04")) |
| Guaranteed Print Area (*2) | Min. 80mm × 138mm (3 ¹ / ₈ " × 5 ⁷ / ₁₆ "") (margin width of 5mm (3 ³ / ₁₆ "")) Max. 306mm × 450mm (12 ¹ / ₁₆ " × 17 ³ / ₄ "") (margin width of 5mm (3 ³ / ₁₆ "")) |
| Feed Tray Capacity (*1) | Paper Feed Tray 1: 1,000 sheets Paper Feed Tray 2: 500 sheets Standard Paper Feed Tray: 1,000 sheets |
| Paper Receiving Tray Capacity (*1) | 1,000 sheets |
| RISO Extended Print Function | Proof copy (set in the driver) / test print (printer) / print position adjustment (20mm (1 ³ / ₁₆ "") in vertical and horizontal directions / adjustable in temporary data in printer) / additional print (temporary data retrieve) |
| Printer Memory | 640MB |
| Power Source | 100 - 240V~, 50/60Hz, 12.0 - 6.0A or more |
| Power Consumption | Maximum: 800W or less Ready (*3): 300W or less Stand-by: 150W or less Sleep mode: 20W or less |
| Operating Noise | Operating: 68dB or less |
| Operating Environment | Temperature: 15°C - 30°C (59°F to 86°F), Humidity: 40% - 70% (no dew condensation) |
| Weight | Approximately 266kg (597.7lb) (including stand) (*4) |
| Dimensions (W × D × H) | In use: 1,800mm × 695mm × 1,135mm (70 ⁷ / ₈ " × 27 ³ / ₈ " × 44 ¹¹ / ₁₆ "") Paper Receiving Tray and Standard Feed Tray folded: 1,220mm × 695mm × 1,135mm (48" × 27 ³ / ₈ " × 44 ¹¹ / ₁₆ "") |

*1 For A4/85g/m² (22.6-lb bond)

*2 When printing onto an envelope, a margin of 10 mm width is made.

*3 The printer is in the print mode but is not printing (at 20°C).

*4 Consumables and controller are not included.

● HC AUTO STACKER (Option)

| | |
|------------------------|--|
| Paper Size | 100mm (*1) - 305mm x 148mm - 432mm (3 ¹⁵ / ₁₆ " (*1) - 12" x 5 ¹³ / ₁₆ " - 17") |
| Paper Weight | 46 g/m ² to 210 g/m ² (12-lb bond to 56-lb bond) Paper |
| Tray Capacity (*2) | It varies according to paper size. Approximately 1,150 sheets for A4/B5/Letter Approximately 500 sheets for A3/B4/Ledger/Legal Approximately 100 sheets for Statement/Postcard/Irregular size |
| Operating Environment | Temperature: 15°C - 30°C (59°F to 86°F), Humidity: 40% - 70% (no dew condensation) |
| Weight | Approximately 19.9 kg (43.9 lb) |
| Dimensions (W x D x H) | 503 mm x 530 mm x 748 mm (19 ¹³ / ₁₆ " x 20 ⁷ / ₈ " x 29 ⁷ / ₁₆ " |

*1 When using "Offset output" function: 131mm (5³/₁₆")

*2 For A4 / 85 g/m² (22.6 lb bond) paper

● Controller Section (If the RISO Controller PS7R-9000 / 5000 is installed)

| Principal Specifications | Controller | RISO Controller PS7R-9000 | RISO Controller PS7R-5000 |
|--|--|---------------------------|----------------------------------|
| | Printer that can be connected | RISO HC5500T | |
| CPU | Intel® Pentium®4 3.4GHz | | Intel® Celeron® 2.9GHz |
| Memory Capacity | 1024MB | | 256MB |
| HDD | 160GB (user available area: 150GB) | | 80GB (user available area: 70GB) |
| | User available area: Job receiving area, Storage and Form storage, Font installation area | | |
| OS | Linux | | |
| Interface | Ethernet / 1000Base-T, 100Base-TX, 10Base-T | | |
| Type | Outside unit type | | |
| Power supply / maximum power consumption | 100 - 240V~, 50/60Hz, 2.5 - 1.8A or more Maximum: 300W | | |
| Dimensions /weight (W x D x H) | 180mm x 405mm x 359mm (7" x 15 ¹⁵ / ₁₆ " x 14 ¹ / ₈ ") / approximately 10kg (22lb) | | |
| PDL (page description language) | Adobe® PostScript®3™ | | |
| Applicable protocol | TCP/IP, Apple Talk® | | |
| Installed font | 139 fonts | | |
| Font download | (by installer supplied with font) | | |
| Applicable OS | Windows 2000 (SP2 or later) / XP (SP1 or later) MacOS9 (9.2.2), MacOSX (10.2.6 or later) | | |

| | | |
|----------------------|--------------------------------|--|
| Principal Functions | Colour Management | "ComColor™ Standard" colour management is provided. * Auto colour matching function based on output setting and paper setting |
| | Pagination | Multi-up (single page) / Multi-up (multi-page) / Booklet / Fold |
| | Image Processing | Gamma control: Contrast / Density Line Smoothing Screening: Error diffusion / Dot screen |
| | Image Position Adjustment | Image position can be adjusted in the vertical and horizontal directions from -20mm to 20mm (- ¹³ / ₁₆ " to ¹³ / ₁₆ ") on both the front and back sides. |
| | Form Function | Registration of form, Overlay Function |
| | Paper Feed/Ejection Processing | Auto tray selection, Duplex printing, Job separation, Printer collate, Support of HC Finisher (optional), Output face setting |
| | Clustering | Job delegation (up to 4 units of controllers can be registered) Job split (Job split limit: Number of pages / Output volume) |
| | Sample page print | Configuration, Sample image, PS font list |
| | Security print | Security code setting, Job name display setting |
| Web Console Function | Monitoring Function | Engine status display, Remaining volume display, Paper information display |
| | Job Manager Function | Job status display Job storage management Archive management Form management Scan and Storage management |
| | Custom Setting Function | Account record display, Storage of history (monthly/ daily), Head maintenance, Network scan |
| | Administrator Function | Network setting, Security setting, Font download, Direct output setting, Storage folder setting, Paper size entry, Initial Setting |
| | Applicable Browser | Windows: Internet Explorer Ver. 6.0 SP1 or later / J2SE1.4.2 or later MacOS9: Internet Explorer Ver. 5.1.6 for Mac or later / MRJ2.2.6 or later MacOSX (10.2 - 10.3): Internet Explorer Ver. 5.2.3 for Mac or later MacOSX (10.4 or later): Safari 2.0 or later |

● Controller Section (If the RISO Controller HC3R-5000 is installed)

| | | |
|--------------------------|--|--|
| Principal Specifications | Printer that can be connected | RISO HC5500T |
| | CPU | Intel® Celeron® 2.9GHz |
| | Memory Capacity | 256MB |
| | HDD | 80GB (user available area: 70GB) User available area: Job receiving area, Storage area |
| | OS | Linux |
| | Interface | Ethernet / 1000Base-T, 100Base-TX, 10Base-T |
| | Type | Outside unit type |
| | Power supply / maximum power consumption | 100 - 240V~, 50/60Hz, 2.5 - 1.8A or more Maximum: 300W |
| | Dimensions / weight (W × D × H) | 180mm × 405mm × 359mm (7" × 15 ¹⁵ / ₁₆ " × 14 ¹ / ₈ ") / approximately 10kg (22lb) |
| | PDL (page description language) | Original PDL |
| | Applicable protocol | TCP/IP |
| | Applicable OS | Windows 2000 (SP2 or later) / XP (SP1 or later) |
| Principal Functions | Colour Management | "ComColor™ Standard" colour management is provided. * Auto colour matching function based on output setting and paper setting |
| | Pagination | Multi-up (single page) / Multi-up (multi-page) / Booklet / Poster |
| | Image Processing | Gamma control: Contrast / Brightness / Chromaticness Line Smoothing Screening: Error diffusion / Dot screen |
| | Image Position Adjustment | Image position can be adjusted in the vertical and horizontal directions from -20mm to 20mm (- ¹³ / ₁₆ " to ¹³ / ₁₆ ") on both the front and back sides. |
| | Paper Feed/Ejection Processing | Auto tray selection, Duplex printing, Job separation, Printer collate, Support of HC Finisher (optional), Output face setting |
| | Sample page print | Configuration, Sample image |
| | Security print | Security code setting, Job name display setting |
| Web Console Function | Monitoring Function | Engine status display, remaining volume display, paper information display |
| | Job Manager Function | Job status display Job storage management Scan and Storage management |
| | Custom Setting Function | Account record display, Storage of history (monthly/ daily), Head maintenance, Network scan |
| | Administrator Function | Network setting, Security setting, Direct output setting, Storage folder setting, Initial Setting |
| | Applicable Browser | Windows: Internet Explorer Ver. 6.0 SP1 or later / J2SE1.4.2 or later |

Index

A

Administration 2-6, 2-31
Arranger 1-16
Auto-Control Stacking Tray 1-4, 1-16

B

Basic Printing Operation 1-18
Beep Sound -Error 2-8, 2-50
Beep Sound -Key 2-8, 2-49
Beep Sound -Status 2-8, 2-49
Between Jobs 2-23
Black (K) Ink Cartridge 1-2

C

CANCEL/BACK Key 2-4
Check Settings Error 3-4
Cleaning Cycle 2-7, 2-40, 2-41
Configuration 2-5, 2-18
Configuration Information Print 2-7, 2-42
Consumables 4-3
Control Panel 1-5
Copy Count 2-7, 2-38
Count Management 2-7, 2-37
Count Pattern 2-7, 2-39, 2-42
Cover Sheet tray 2-6
Cover Sheet Tray
(only if an HC Finisher is connected) 2-30
Cursor Keys 2-4
Cyan (C) Ink Cartridge 1-2

D

Data indicator 2-2
Default gateway 2-45
Description of error 2-3
DHCP 2-45
Displayed Language 2-8, 2-50
Double Feed Check 2-5, 2-21
Duplex Display 2-3
Duplex Indicator 2-2
Duplex Transfer Unit 3-12

E

Eject Wing 2-6, 2-26
End Guide 1-16
Envelope 1-21
Error indicator 3-2
Error Message 3-2, 3-3
Error Number 3-2, 3-3

Error number 2-3
Every Division 2-23

F

Feed Tray 1 2-5, 2-19, 2-54
Feed Tray 2 2-5, 2-19, 2-54
Feed Tray Descent Button 1-2, 1-15
Feed Tray Paper Guide 1-2
Feed Tray Relay 1-15, 2-6, 2-21
Feed Tray Selection 2-9, 2-54
Finisher Functions 4-2
FORCEJET™ Link Symbol 1-5, 3-2, 3-3
Front Cover 2-2
Front Cover (left) 3-5
Front Cover (right) 3-5

G

Guaranteed Print Area viii

H

HC Auto Stacker 1-6, 3-17
Head Maintenance 2-7, 2-40
Head Recovery 2-9, 2-53
High-Quality 1 2-35
High-Quality 2 2-35
How to Close the Standard Feed Tray 1-15
Hyper-Cleaning 2-7, 2-40

I

Image Area 2-6
Image Area (Maximum Print Area) 2-29
Initial Setting 2-8, 2-46
Ink Cartridge vii, 3-18, 4-3
Ink Cartridge Replacement 3-18
Ink Cover 1-2, 3-5, 3-19
Ink Drain Tank 3-7
Ink Replacement Error 3-4
Ink Unit 1-2
IP address 2-45
Items That Can Be Set from the Menu 2-5

J

Job Clear 2-9, 2-55
Job Separation 2-6, 2-23

L

LAN cable x
Left Transfer Path Cover 1-2, 3-5

| | |
|-------------------------------------|--------|
| List of Options | 4-2 |
| Location for Installation | iv, vi |

M

| | |
|-------------------------------------|-----------|
| Magenta (M) Ink Cartridge | 1-2 |
| Main Display | 1-2, 1-5 |
| Main Power Switch | 1-4, 1-10 |
| Maintenance Door | 1-2 |
| Maintenance Call. | 3-7 |
| Maximum Print Area | ix |
| Menu Auto-Shut OFF | 2-8, 2-52 |
| MENU Key. | 2-4 |
| Menu name | 2-2 |
| Menu number | 2-2 |
| Menu Setting | 2-7, 2-42 |
| Menu Shut OFF Time | 2-9, 2-52 |
| Message Display | 1-5, 2-2 |
| Metric/Inch Switch | 2-8, 2-50 |

N

| | |
|--------------------------------|-----------------|
| Network Configuration. | 2-8, 2-45 |
| Normal Cleaning | 2-7, 2-40, 2-41 |

O

| | |
|--------------------------------------|------|
| OK Key | 2-4 |
| Operation Environment | vi |
| Original Size/Tray Display | 2-3 |
| Output volume | 1-19 |
| Overall Dimensions | vi |

P

| | |
|--|----------------------|
| Paper Arranger | 1-4, 1-16 |
| Paper Ejection | 2-6, 2-25 |
| Paper Feed Control. | 7 |
| Paper Feed Pressure | 1-14 |
| Paper Feed Pressure Adjustment Dial | 1-2, 3-22 |
| Paper Feed Pressure Adjustment Lever | 1-2, 1-14 |
| Paper Feed Tray | 1-2, 1-12 |
| Paper Feed Tray 1 | 3-15 |
| Paper Feed Tray 2. | 3-15 |
| Paper Jam Error | 3-6 |
| Paper Jam in the Standard Paper Feed Tray. | 3-9 |
| Paper jam occurs. | 3-9 |
| Paper Receiving Section | 3-10 |
| Paper Receiving Tray | 1-16, 1-20 |
| Paper Size. | 2-5, 2-6, 2-20, 2-30 |
| Paper Size Display | 2-2 |
| Paper Size Entry | 2-6, 2-32 |
| Paper Top Guide | 1-12 |
| Paper Type | 2-5, 2-7, 2-20, 2-34 |
| Paper Type Entry. | 2-6, 2-33 |
| Power Key | 1-5 |
| Power Switch. | 1-10 |

| | |
|----------------------------------|-----------|
| Print Auto-ON Time. | 2-8, 2-51 |
| Print Density | 2-6, 2-24 |
| Print Mode Auto-ON | 2-8, 2-51 |
| Print Position Adjust | 2-5, 2-14 |
| Print Quantity Display | 2-2, 2-3 |
| Print range | 1-19 |
| Printer Configuration. | 2-1 |
| PRINT/PAUSE Key | 1-5, 2-4 |

R

| | |
|--|----------|
| Registration | 2-7 |
| Remaining Volume Notice Indicators | 1-5, 3-2 |
| Right Transfer Path Cover. | 3-5 |
| RISO Scanner HS2000. | 4-2 |

S

| | |
|-------------------------------------|---------------------|
| Separation Paper | 2-7, 2-36 |
| Shifting Guide | 2-6, 2-27 |
| Side Guide | 1-16 |
| Side Guide Locking Levers | 1-12 |
| Sleep. | ix, 1-10, 2-8, 2-48 |
| Sleep Key | 1-10 |
| Specifications | 4-4 |
| Stack Guide | 2-6, 2-26 |
| Stack Guide Adjust | 2-6, 2-27 |
| Stack Guide (end) | 1-4, 1-16 |
| Stack Guide Open Button | 1-4, 1-17, 1-20 |
| Stack Guide (side) | 1-4, 1-16 |
| Standard Feed Tray. | 2-5, 2-19, 2-54 |
| Standard Paper 1 | 2-35 |
| Standard Paper Feed Tray | 1-2, 1-13 |
| Stand-by | 2-9, 2-52 |
| Stand-by Period | 2-9, 2-53 |
| Status | 2-2, 2-3 |
| Submenu. | 2-11 |
| Subnet mask. | 2-45 |
| System Error. | 3-6 |
| System Information. | 2-7, 2-42 |

T

| | |
|---------------------------------|-----------|
| Temp Data Clear | 2-6, 2-28 |
| Temp Data Retrieve | 2-5, 2-17 |
| Test Print. | 2-5, 2-16 |
| Transfer Roller. | 3-10 |
| Transfer Section Door. | 1-2, 3-5 |
| Transfer Unit | 3-16 |
| Transfer Unit (left) | 3-14 |
| Transfer Unit (right) | 3-11 |
| Tray Selection Rule. | 2-8, 2-51 |
| Triple-Tray Source. | 2-6, 2-22 |

U

| | |
|--------------------------|-----|
| Unusable Paper | 1-8 |
|--------------------------|-----|

Usable Paper 1-7

V

Vent Hole 1-4

W

Waiting Time 2-8, 2-48

WAKE-UP key 1-5, 1-10

Warning 3-7

Y

Yellow (Y) Ink Cartridge 1-2, 3-19