

Welcome to BMW

We congratulate you on your choice of a vehicle from BMW Motorrad and welcome you to the community of BMW riders. Familiarise yourself with your new vehicle so that you can ride it safely and confidently in all traffic situations.

About this Rider's Manual

Please read this Rider's Manual carefully before starting to use your new BMW. It contains important information on how to operate the controls and how to make the best possible use of all your BMW's technical features. In addition, it contains information on maintenance and care to help you maintain your vehicle's reliability and safety, as well as its value.

This record of the maintenance work you have had performed on

your vehicle is a precondition for generous treatment of goodwill claims.

If the time comes to sell your BMW, please remember to hand over this Rider's Manual to the new owner. It is an important part of the vehicle.

Suggestions and criticism

If you have questions concerning your vehicle, your authorised BMW Motorrad dealer will gladly provide advice and assistance.

We hope you will enjoy riding your BMW and that all your journeys will be pleasant and safe

BMW Motorrad.

01 40 8 403 696

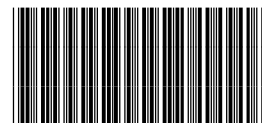

Table of Contents

1 General instructions	5	Warnings	25	Cruise-control system	81
Overview	6	4 Operation.....	55	Hill Start Control	84
Abbreviations and symbols	6	Ignition switch/steering lock	56	Anti-theft alarm (DWA)	85
Equipment	7	Ignition with Keyless Ride	58	Tyre pressure monitoring (RDC)	88
Technical data	7	Emergency off switch (kill switch)	62	Heated handlebar grips	88
Actuality	7	Intelligent emergency call	63	On-board computer	89
2 General views	9	Lights	65	Front and rear seats	90
General view, left side	11	Daytime riding light	67	Stowage compartment	92
General view, right side	13	Hazard warning lights system	69	5 V charger interface	93
Underneath the seat	14	Turn indicators	69	5 TFT display	95
Multifunction switch, left	15	Anti-lock brake system (ABS)	70	General instructions	96
Multifunction switch, right	17	Automatic Stability Control (ASC)	72	Principle	97
Instrument panel	18	Dynamic Traction Control (DTC)	73	Pure Ride view	103
3 Status indicators	19	Electronic Suspension Adjustment (D-ESA)	75	General settings	105
Indicator and warning lights	20	Riding mode	78	Bluetooth	106
TFT display in Pure Ride view	22			My Vehicle	110
TFT display in the View menu	24			Navigation	113
				Media	115
				Phone	115
				Switch GPS synchronisation on or off	116
				Display software version	116

Display licence information	116	Parking your motorcycle	137	Engine oil	162
6 Adjustment.....	117	Refuelling	138	Brake system	164
Mirrors	118	Securing motorcycle for transportation	142	Clutch	168
Headlight	118	8 Engineering details	145	Coolant.....	168
Windscreen	119	General instructions	146	Tyres.....	169
Clutch	120	Anti-lock brake system (ABS).....	146	Wheel rims and tyres.....	170
Brakes	120	Automatic Stability Control (ASC)	149	Wheels	171
Shift mechanism	121	Dynamic Traction Control (DTC)	150	Air filter.....	177
Handlebars	122	Dynamic ESA	152	Light source.....	179
Spring preload	122	Riding mode	152	Jump-starting	184
Damping	123	Tyre pressure monitoring (RDC)	155	Battery	185
7 Riding.....	125	Shift assistant	156	Fuses	189
Safety instructions	126	Hill Start Control	157	Diagnostic connector.....	190
Comply with checklist.....	128	9 Maintenance	159	10 Accessories	193
Always before riding off:	129	General instructions	160	General instructions	194
Every 3rd refuelling stop	129	Tool kit.....	160	Power sockets	194
Starting.....	129	Service toolkit	161	Cases	195
Running in	132	Front-wheel stand.....	161	Topcase.....	197
Off-roading	133			Navigation system.....	199
Shifting gear	134			11 Care	205
Brakes	135			Care products.....	206
				Washing the vehicle.....	206
				Cleaning easily damaged components.....	207
				Paint care	208

Protective wax coating	208	13 Service 229
Laying up the motor- cycle	208	BMW Motorrad Service . . .
Restoring motorcycle to use	209	BMW Motorrad Mobility services
12 Technical data 211		Maintenance work
Troubleshooting chart	212	BMW Service
Screw connections	215	Maintenance schedule . . .
Fuel	217	Maintenance confirma- tions
Engine oil	218	Service confirmations
Engine	218	14 Appendix 251
Clutch	219	Certificate for Electronic Immobiliser
Transmission	219	Certificate for Key- less Ride
Rear-wheel drive	220	Certificate for Tyre Pres- sure Control (RDC)
Frame	221	Certificate for TFT instru- ment cluster
Chassis and suspension	221	15 Index 260
Brakes	222	
Wheels and tyres	223	
Electrical system	225	
Anti-theft alarm	226	
Dimensions	227	
Weights	228	
Riding specifications	228	

General instructions

Overview 6
Abbreviations and symbols 6
Equipment 7
Technical data 7
Actuality 7

Overview

An important aspect of this Rider's Manual is that it can be used for quick and easy reference. Consulting the extensive index at the end of this Rider's Manual is the fastest way to find information on a particular topic or item. To first read an overview of your motorcycle, please go to Chapter 2. All maintenance and repair work on the motorcycle is documented in Chapter 12. This record of the maintenance work you have had performed on your vehicle is a precondition for generous treatment of goodwill claims. When the time comes to sell your BMW, please remember to hand over this Rider's Manual; it is an important part of the motorcycle.

Abbreviations and symbols



CAUTION Low-risk hazard. Non-avoidance can lead to slight or moderate injury.



WARNING Medium-risk hazard. Non-avoidance can lead to fatal or severe injury.



DANGER High-risk hazard. Non-avoidance leads to fatal or severe injury.





ATTENTION Special notes and precautionary measures. Non-compliance can lead to damage to the vehicle or accessory and, consequently, to voiding of the warranty.



NOTICE Specific instructions on how to operate, control, adjust or look after items of equipment on the vehicle.

◀ Indicates the end of an item of information.

- Instruction.
- » Result of an activity.
- ⇒ Reference to a page with more detailed information.
- ◁ Indicates the end of a passage relating to specific accessories or items of equipment.
-  Tightening torque.
-  Technical data.
- NV National-market version.

- OE Optional extras. The vehicles are assembled complete with all the BMW Motorrad optional extras originally ordered.
- OA Optional accessories. You can obtain BMW Motorrad optional accessories through your authorised BMW Motorrad dealer; optional accessories have to be retrofitted to the vehicle.
- ABS Anti-lock brake system.
- ASC Automatic Stability Control.
- D-ESA Electronic chassis and suspension adjustment.

- DTC Dynamic Traction Control (optional extra only in combination with Pro riding modes).
- DWA Anti-theft alarm (Diebstahlwarnanlage).
- EWS Electronic immobiliser.
- RDC Tyre pressure monitoring.

Equipment

When you purchased your BMW motorcycle, you chose a model with individual equipment. This Rider's Manual describes the optional extras (OE) offered by BMW and selected optional accessories (OA). This explains why the manual may also contain equipment specifications which you have not ordered. Please note, too, that your motorcycle might not be exactly as illus-

trated in this manual on account of country-specific differences. If your motorcycle contains equipment that has not been described, its description can be found in a separate manual.

Technical data

All dimensions, weights and power ratings stated in the Rider's Manual are quoted to the standards and comply with the tolerance requirements of the Deutsches Institut für Normung e.V. (DIN). Versions for individual countries may differ.

Actuality

The high safety and quality level of BMW motorcycles is ensured by continuous development work on design, equipment and accessories. Because of this, your motorcycle may differ from the information supplied in the Rider's Manual. Nor

1

∞

can BMW Motorrad entirely rule out errors and omissions. Consequently no claims can be derived from the information, graphics or descriptions.

General instructions

General views

General view, left side 11
General view, right side 13
Underneath the seat 14
Multifunction switch, left 15
Multifunction switch, right 17
Instrument panel 18



General view, left side

- 1 Fuel filler neck (→ 138)
- 2 Seat lock (→ 90)
- 3 Setting the rear damping
(down at the spring strut)
(→ 123)

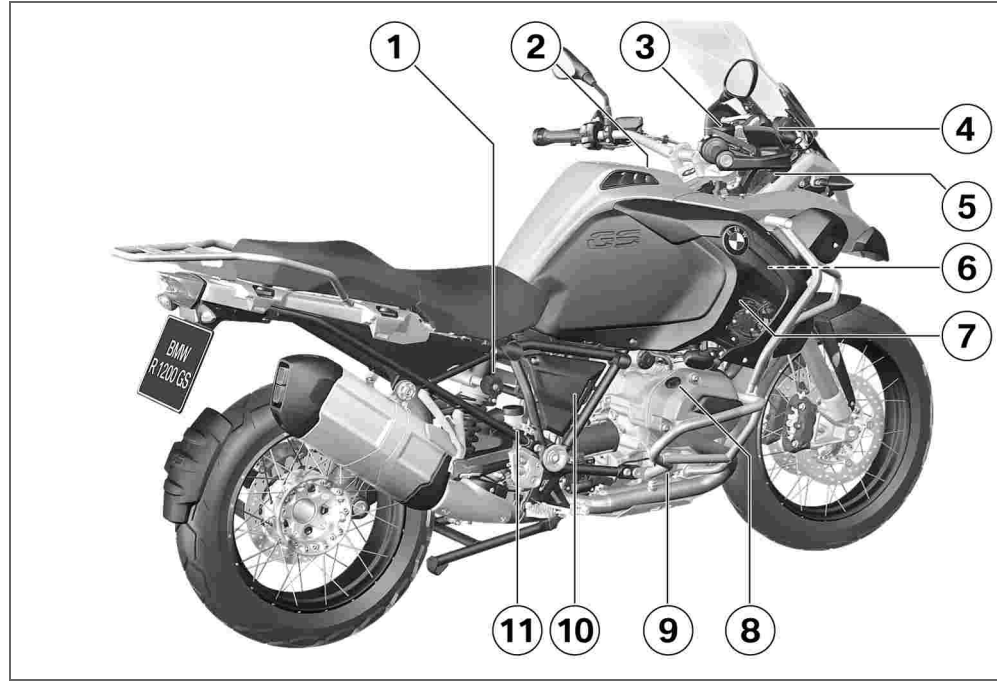

General view, right side

- 1** Adjuster for spring preload, rear (➡ 122)
- 2** Air filter (underneath the centre trim panel) (➡ 177)
- 3** Brake-fluid tank, front (➡ 166)
- 4** Height adjustment of the windscreen (➡ 119)
- 5** Power socket (➡ 194)
- 6** VIN (on steering-head bearing)
Type plate (on steering-head bearing)
- 7** Coolant-level indicator (➡ 168)
Coolant reservoir (➡ 169)
- 8** Oil filler neck (➡ 163)
- 9** Engine oil level indicator (➡ 162)
- 10** Behind the side trim panel:
Battery (➡ 185)
Battery-positive connection point (➡ 184)
Diagnostic connector (➡ 190)
- 11** Brake-fluid reservoir, rear (➡ 167)

Underneath the seat

- 1 Standard toolkit (→ 160)
- 2 Rider's Manual
- 3 Tyre pressure table
- 4 Payload table
- 5 Adjusting the front seat height (→ 91)
- 6 Fuses (→ 189)

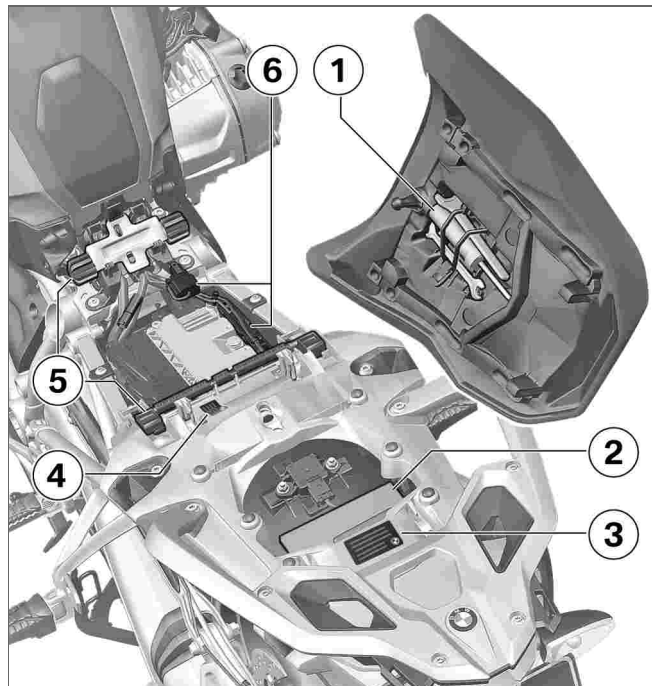

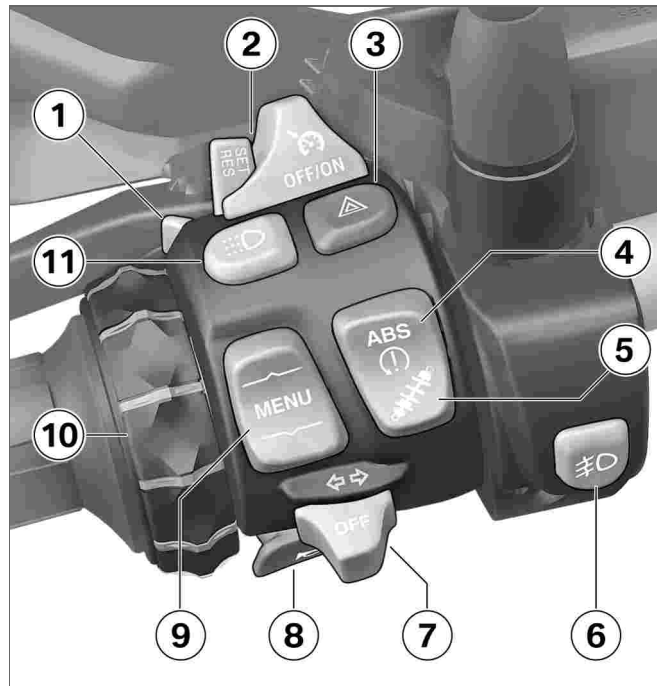

Multifunction switch, left

- 1** High-beam headlight and headlight flasher (→ 66)
- 2** – with cruise control^{OE}
Cruise-control system (→ 82).
- 3** Hazard warning lights system (→ 69)
- 4** ABS (→ 70)
ASC (→ 72)
– with riding modes Pro^{OE}
DTC (→ 73)
- 5** – with Dynamic ESA^{OE}
Dynamic ESA possible settings (→ 75)
- 6** – with LED auxiliary headlights^{OA}
Auxiliary headlights (→ 66).
- 7** Turn indicators (→ 69)
- 8** Horn
- 9** MENU/ rocker switch (→ 97)

- 10 Multi-Controller Controls (→ 97)
- 11 – with daytime riding light^{OE}
Manual daytime riding light (→ 67).

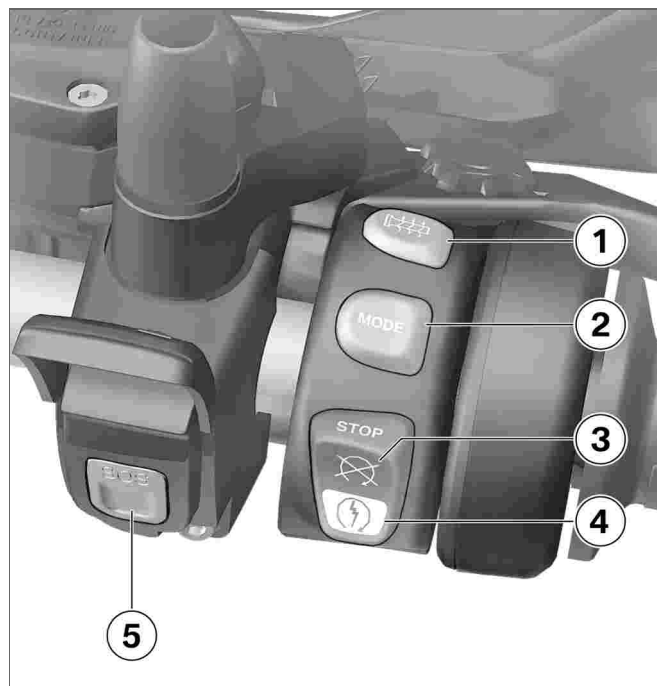

Multifunction switch, right

- 1 – with heated grips^{OE}
Heated handlebar grips
([↗ 88](#)).
- 2 Riding mode ([↗ 78](#))
- 3 Emergency off switch (kill
switch) ([↗ 62](#))
- 4 Starter button
Starting the engine
([↗ 129](#)).
- 5 SOS button
Intelligent emergency call
([↗ 63](#))

2

17

General views

Instrument panel

- 1 Indicator and warning lights
([↗ 20](#))
- 2 TFT display ([↗ 22](#))
([↗ 24](#))
- 3 Alarm system LED
– with alarm system
(DWA)^{OE}
Alarm signal ([↗ 86](#))
– with Keyless Ride^{OE}
Telltale light for the radio-
operated key
Switching on ignition
([↗ 59](#)).
- 4 Photosensor (for adapting
the brightness of the in-
strument lighting)

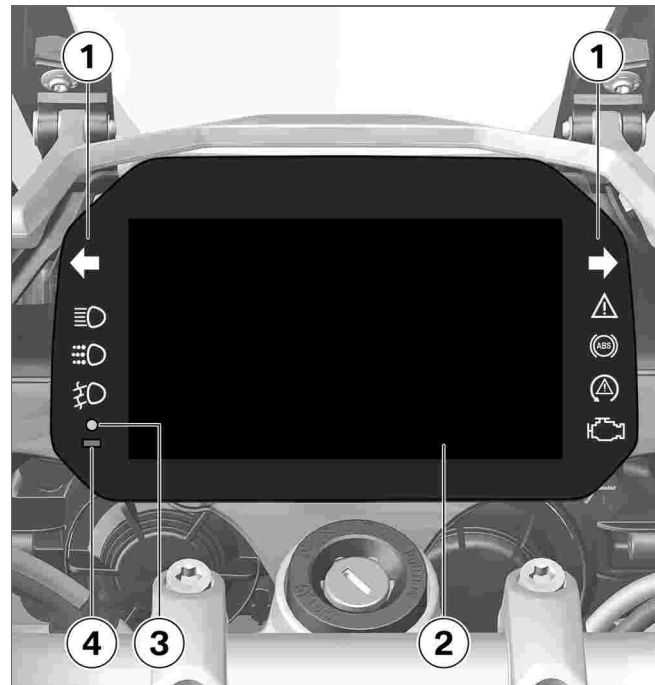



Status indicators

Indicator and warning lights 20
TFT display in Pure Ride view 22
TFT display in the View menu 24
Warnings 25

Indicator and warning lights

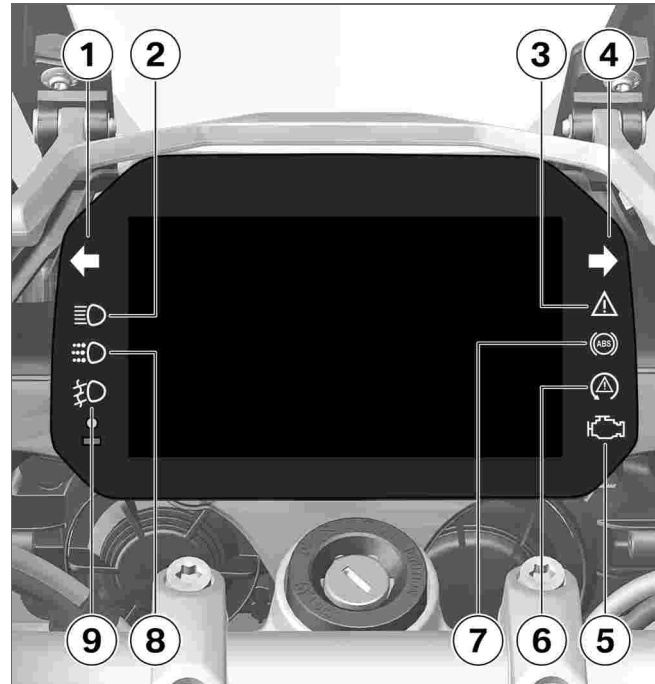
- 1 Turn indicators, left
Operating the turn indicators (► 69).
- 2 High-beam headlight
(► 66)
- 3 General warning light
(► 25)
- 4 Turn indicators, right
- 5 - With export to EU markets^{NV}
Malfunction indicator lamp
Emissions warning (► 41)
- 6 ASC (► 49)
- with riding modes Pro^{OE}
DTC (► 50)
- 7 ABS (► 70)
- 8 - with daytime riding light^{OE}
Manual daytime riding light
(► 67).



- 9** – with LED auxiliary headlights^{OA}
Auxiliary headlights
( 66).

TFT display in Pure Ride view

- 1 Hill Start Control (→ 52)
- 2 Change of operating focus (→ 101)
- 3 Engine speed display (→ 103)
- 4 Rider info status line (→ 102)
- 5 Speedometer
- 6 Coding plug (→ 80)
- 7 Riding mode (→ 78)
- 8 Recommendation to up-shift (→ 104)
- 9 Gear indicator; "N" indicates neutral.
- 10 Speed Limit Info (→ 103)
- 11 – with cruise control^{OE}
Cruise-control system (→ 82).
- 12 Clock (→ 105)
- 13 Connection status (→ 107)
- 14 Muting (→ 105)

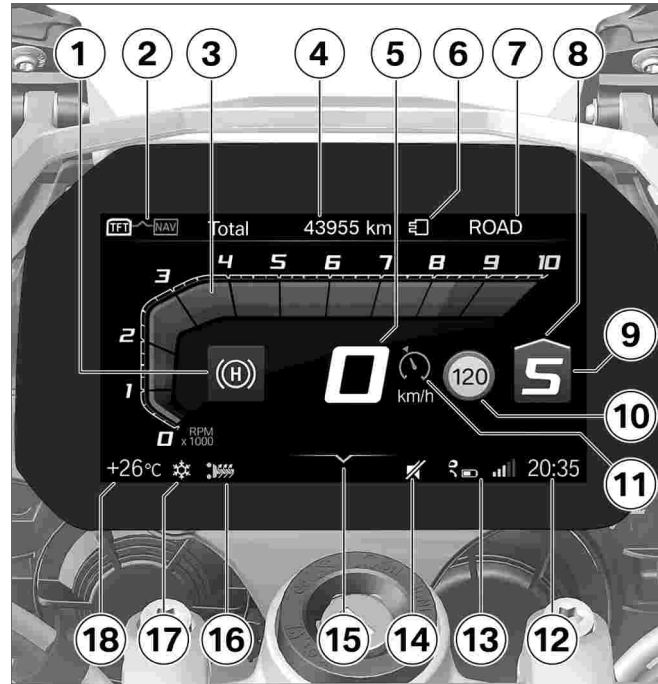

- 15** Operating help
- 16** Heating stages, handlebar grips (⇒ 88)
- 17** Outside temperature warning (⇒ 36)
- 18** Ambient temperature

TFT display in the View menu

- 1 Hill Start Control (→ 52)
- 2 Speedometer
- 3 – with cruise control^{OE}
Cruise-control system (→ 82).
- 4 Speed Limit Info (→ 103)
- 5 Coding plug (→ 80)
- 6 Riding mode (→ 78)
- 7 Rider info status line (→ 102)
- 8 Recommendation to up-shift (→ 104)
- 9 Gear indicator; "N" indicates neutral.
- 10 Clock
- 11 Connection status
- 12 Muting (→ 105)
- 13 Operating help
- 14 Menu area
- 15 Heating stages, handlebar grips (→ 88)

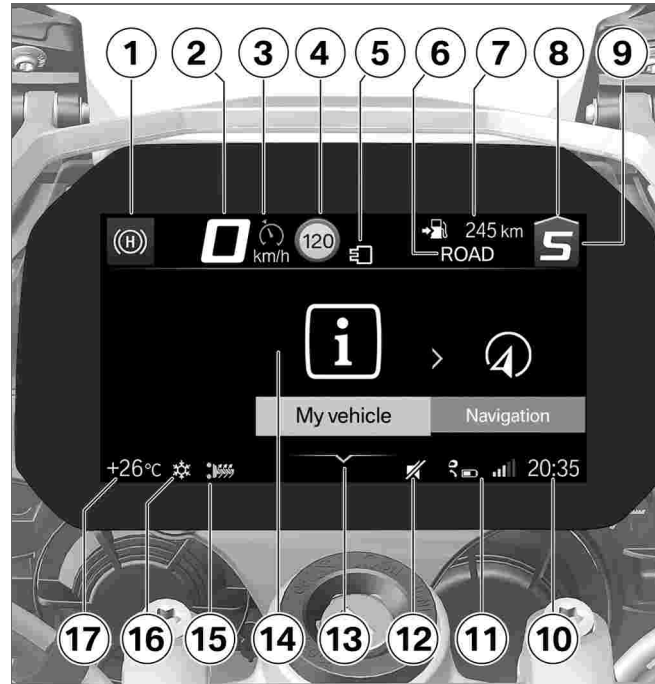

- 16 Outside temperature warning (→ 36)
- 17 Ambient temperature

Warnings

Mode of presentation

Warnings are indicated by the corresponding warning lights. Warnings are displayed by the general warning lights in conjunction with a dialogue box on the TFT display. The 'general' warning light shows yellow or red, depending on the urgency of the warning.



The status of the 'General' warning light matches the most urgent warning. The possible warnings are listed on the next pages.

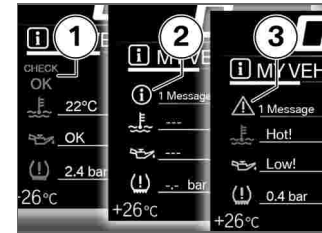

Check control display

The messages on the display are shown in different ways. Different colours and symbols are used depending on priority:

- Green CHECK OK **1**: no message, optimum value.
- White circle with small "i" **2**: information.
- Yellow warning triangle **3**: warning message, value not ideal.
- Red warning triangle **3**: warning message, critical value

Status indicators

3

25

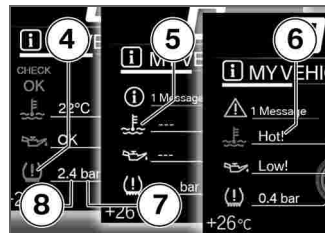

Value display

The symbols **4** are shown in different ways. Depending on the evaluation, different colours are used. Instead of numerical values **8** with units **7**, text **6** is always used on the display:

Colour of the symbol

- Green: (OK) Current value is ideal.
- Blue: (Cold!) Current temperature is too low.
- Yellow: (Low! /High!) Current value is too low or too high.

- Red: (Hot! /High!) Current temperature or value is too high.
- White: (---) There is no valid value. Dashes **5** are displayed instead of the value.

NOTICE

The assessment of some values is only possible from a certain journey duration or speed. If a measured value is still not being displayed because the conditions for measurement have not been met, dashes are displayed instead as a placeholder. If there are no valid measured values, there will be no assessment in the form of a coloured symbol. ◀

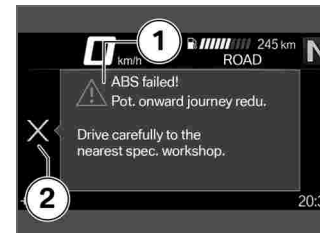











Check control dialogue box











Messages are given in the form of a check control dialogue box **1**.











- If there are multiple check control messages of equal priority, the messages alternate in the order in which they occurred until they are acknowledged.
- If symbol **2** is actively displayed, it can be acknowledged by tilting the multi-controller to the left.
- Check control messages are attached dynamically to the pages in the Vehicle menu as additional tabs (▣ 99). As









long as the problem persists,
the message can be called up
again.











Warnings, overview**Indicator and warning lights****Display text****Meaning**









			Ice crystal symbol is displayed.	Outside temperature warning (►► 36)
	General warning light shows yellow.		Remote key not in range.	Radio-operated key out of range (►► 36)
	General warning light shows yellow.		Remote key battery at 50%.	Replace the battery of the radio-operated key (►► 37)
			Remote key battery weak.	
	General warning light shows yellow.		is displayed in yellow.	Vehicle voltage too low (►► 37)
			Vehicle voltage low.	
	General warning light shows red.		is displayed in red.	Vehicle voltage critical (►► 38)











Indicator and warning lights	Display text	Meaning
	 Vehicle voltage critical!	Vehicle voltage critical (→ 38)
 General warning light shows yellow.	 The faulty bulb is displayed.	Bulb faulty (→ 38)
	 Alarm system batt. capacity weak.	Anti-theft alarm battery weak (→ 39)
 General warning light shows yellow.	 Alarm system battery empty.	Anti-theft alarm battery flat (→ 40)
	 Oil level too low! Check oil level.	Engine-oil level too low (→ 40)
 General warning light shows red.	 Coolant temperature too high!	Coolant temperature too high (→ 41)
 The malfunction indicator lamp lights up.	 Exhaust re-treatment impaired.	Emissions warning (→ 41)









Indicator and warning lights	Display text	Meaning
 General warning light shows yellow.	 Engine control failure!	Engine control failed (►► 41)
 General warning light shows yellow.	 Fault in the engine control.	Engine in emergency-operation mode (►► 42)
 General warning light flashes yellow.	 Serious fault in the engine control!	Severe fault in the engine control (►► 42)
 General warning light shows yellow.	 is displayed in yellow.	Tyre pressure in limit range of the permitted tolerance (►► 44)
	 Tyre pressure does not match setpoint	
 General warning light flashes red.	 is displayed in red.	Tyre pressure outside the permitted tolerance (►► 44)

Indicator and warning lights	Display text	Meaning
	 Tyre pressure does not match setpoint	Tyre pressure outside the permitted tolerance (→ 44)
	 Tyre press. control. Loss of pressure.	
	 "----"	Transmission fault (→ 45)
 General warning light shows yellow.	 "----"	Sensor faulty or system fault (→ 46)
 General warning light shows yellow.	 RDC sensor battery weak..	Battery for tyre pressure sensor weak (→ 46)
	 Drop sensor faulty.	Drop sensor defective (→ 47)
	 Emergency call failure.	Emergency call function restricted (→ 47)

Indicator and warning lights	Display text	Meaning
	 Side stand monitoring faulty.	Side stand monitoring is faulty (→ 47)
 ABS telltale and warning light flashes.		ABS self-diagnosis not completed (→ 47)
 ABS indicator and warning light shows.	 Off!	ABS deactivated (→ 47)
	 ABS deactivated.	
 ABS indicator and warning light shows.	 Limited ABS availability!	ABS fault (→ 48)
 ABS indicator and warning light shows.	 ABS failure!	ABS failed (→ 48)
 ABS indicator and warning light shows.	 ABS Pro failure!	ABS Pro failed (→ 48)

Indicator and warning lights	Display text	Meaning
 ASC indicator and warning light flashing quickly.		ASC intervention (►►► 49)
 ASC indicator and warning light flashing slowly.		ASC self-diagnosis not completed (►►► 49)
 ASC indicator and warning light shows.	 Off!	ASC switched off (►►► 49)
	 Traction control deactivated.	
 ASC indicator and warning light shows.	 Traction control failure!	ASC fault (►►► 49)
 DTC indicator and warning light flashes quickly.		DTC intervention (►►► 50)
 DTC indicator and warning light flashes slowly.		DTC self-diagnosis not completed (►►► 50)

Indicator and warning lights	Display text	Meaning
 DTC indicator and warning light shows.	 Off!	DTC switched off (→ 50)
	 Traction control deactivated.	
 DTC indicator and warning light shows.	 Traction control failure!	DTC fault (→ 51)
 General warning light shows yellow.	 Spring strut adjustment faulty!	D-ESA fault (→ 51)
	 Tankreserve erreicht.	Fuel down to reserve (→ 52)
	 The holding symbol is displayed.	Hill Start Control activated (→ 52)
 General warning light flashes yellow.	 The holding symbol flashes briefly.	Hill Start Control is deactivated automatically (→ 52)

Indicator and warning lights	Display text	Meaning
 General warning light flashes yellow.	 The holding symbol flashes briefly.	Hill Start Control cannot be activated (→ 52)
	 The gear indicator flashes.	Gear not trained (→ 53)
 Turn signal indicator light flashes green.		Hazard warning lights system is switched on (→ 53)
 Turn signal indicator light flashes green.		
	 is displayed in white.	Service due (→ 54)
	Service due!	
 General warning light shows yellow.	 is displayed in yellow.	Service-due date has passed (→ 54)
	Service overdue!	

Ambient temperature

The ambient temperature is displayed status line of the TFT display.

When the motorcycle is at a standstill, the heat of the engine can falsify the ambient-temperature reading. If the heat of the engine is affecting it too much, dashes are temporarily shown in place of the value.



If the ambient temperature falls below the following limit value, there is a risk of black ice.



Limit value for the ambient temperature

approx. 3 °C

Once the temperature has fallen below that value, the ambient temperature display along with a snowflake symbol flashes in the status line on the TFT display.

Outside temperature warning



Ice crystal symbol is displayed.

Possible cause:



The air temperature measured at the vehicle is lower than:

approx. 3 °C

! WARNING

Risk of black ice also applicable at over 3°C

Risk of accident

- Always take extra care when temperatures are low; remember that there is particular danger of black ice forming on bridges and where the road is in shade, ◀
- Ride carefully and think well ahead.

Radio-operated key out of range

– with Keyless Ride^{OE}



General warning light shows yellow.



Remote key not in range. Do not stop engine. Not possible to restart the engine.

Possible cause:

Communication between R/C key and engine electronics is disrupted.

- Check the battery in the radio-operated key.
– with Keyless Ride^{OE}
- Replace the battery of the radio-operated key (▶▶ 61).
- Use the reserve key to continue your journey.

- with Keyless Ride^{OE}
- Battery of the radio-operated key is empty or loss of the radio-operated key (►► 61).
- If a check control dialogue box appears during the journey, remain calm. You can continue your journey; the engine will not switch off.
- Have the defective radio-operated key replaced by an authorised BMW Motorrad dealer.

Replace the battery of the radio-operated key

 General warning light shows yellow.

 Remote key battery at 50%. No functional impairment.

 Remote key battery weak. Limited central lock-

ing function. Change battery.

Possible cause:

- The integral battery in the radio-operated key has lost a significant proportion of its original capacity. There is no assurance of how long the R/C key can remain operational.
- with Keyless Ride^{OE}
- Replace the battery of the radio-operated key (►► 61).

Vehicle voltage too low

 General warning light shows yellow.

 is displayed in yellow.

 Vehicle voltage low. Switch off unnecessary consumers.

WARNING

Discharged battery causes various motorcycle systems to fail, such as lighting, engine or ABS

Risk of accident

- Do not continue your journey.◀

The battery will not be charged. By continuing to drive on, the vehicle electronics discharge the battery.

NOTICE

If the 12 V battery is not correctly installed or if the polarity of the terminals is reversed (e.g. in an attempt to jump-start the vehicle), this can cause the fuse for the alternator regulator to blow.◀

Possible cause:

Alternator or alternator drive faulty or fuse for alternator regulator has blown.

- Have the fault rectified as quickly as possible by a specialist workshop, preferably an authorised BMW Motorrad dealer.

Vehicle voltage critical

 General warning light shows red.

 is displayed in red.

 Vehicle voltage critical! Consumers were switched off. Check battery condition.

WARNING

Discharged battery causes various motorcycle systems

to fail, such as lighting, engine or ABS

Risk of accident

- Do not continue your journey.◀

The battery will not be charged. By continuing to drive on, the vehicle electronics discharge the battery.

NOTICE

If the 12 V battery is not correctly installed or if the polarity of the terminals is reversed (e.g. in an attempt to jump-start the vehicle), this can cause the fuse for the alternator regulator to blow.◀

Possible cause:

Alternator or alternator drive faulty or fuse for alternator regulator has blown.

- Have the fault rectified as quickly as possible by a specialist workshop, preferably

an authorised BMW Motorrad dealer.

Bulb faulty

 General warning light shows yellow.

 The faulty bulb is displayed:

 High beam faulty!

 Front left turn indicator faulty!
or Front right turn indicator faulty!

 Low-beam headlight faulty!

 Front side light faulty!

– with LED headlight^{OE}

 Daytime riding light faulty!◀

 Left additional headlight faulty!
or Right additional headlight faulty!

 Tail light faulty!

 Brake light faulty!

 Rear left turn indicator faulty!
or Rear right turn indicator faulty!

 Number plate light faulty!

- Have it checked by a specialist workshop.

 **WARNING**

Vehicle overlooked in traffic due to failure of the lights on the vehicle

Safety risk

- Replace defective bulbs as soon as possible; always carry a complete set of spare bulbs if possible.◀

Possible cause:

One or more bulbs defective.

- Identify defective bulb or bulbs by visual check.
- Replacing bulbs for low-beam and high-beam headlight (► 179).
- Replacing bulb for parking light (► 180).
- LED headlight, replacing (► 183).
- Replacing bulbs for front and rear turn indicators (► 182).
- Replacing LED rear light (► 183).
- with LED flashing turn indicators^{OE}
- Replace LED flashing turn indicators (► 183).

Anti-theft alarm battery weak

- with alarm system (DWA)^{OE}

 Alarm system batt. capacity weak. No restrictions. Make an appointment at a specialist workshop.

 **NOTICE**

This error message shows briefly only after the Pre-Ride-Check completes.◀

Possible cause:

The integral battery in the anti-theft alarm has lost a significant proportion of its original capacity. There is no assurance of how long the anti-theft alarm can remain operational if the vehicle's battery is disconnected.

- Seek the advice of a specialist workshop, preferably an authorised BMW Motorrad dealer.

Anti-theft alarm battery flat

- with alarm system (DWA)^{OE}



General warning light shows yellow.



Alarm system battery empty. No independent alarm. Make an appointment at a specialist workshop.



NOTICE

This error message shows briefly only after the Pre-Ride-Check completes. ◀

Possible cause:

The integral battery in the anti-theft alarm has lost its entire original capacity. There is no assurance that the anti-theft alarm will be operational if the vehicle's battery is disconnected.

- Seek the advice of a specialist workshop, preferably an authorised BMW Motorrad dealer.

Electronic oil-level check



The electronic oil-level check rates the oil level in the engine as OK or Low!

The preconditions for the oil level check are as follows:

- Engine at operating temperature.
- Engine idling for at least ten seconds.
- Side stand retracted.

- Motorcycle standing upright on a smooth, level surface.

The those preconditions are not met, the oil level cannot be measured. Dashes will be displayed in place of the information.

Engine-oil level too low



Oil level too low! Check oil level.

Possible cause:

The electronic oil-level sensor has registered an excessively low oil level. The next time you stop for fuel:

- Checking engine oil level (➡ 162).

If the oil level is too low:

- Top up the engine oil (➡ 163).

If the oil level is correct:

- Seek the advice of a specialist workshop, preferably an authorised BMW Motorrad dealer.

Coolant temperature too high

 General warning light shows red.

 Coolant temperature too high! Check coolant level. Continue riding in part-load to cool down.

ATTENTION

Riding with overheated engine

Engine damage

- Compliance with the information set out below is essential.◀

Possible cause:

The coolant level is too low.

- Check coolant level (▶ 168).

If the coolant level is too low:

- Top up the coolant and have the coolant system checked

by a specialist workshop, preferably by an authorised BMW Motorrad dealer.

Possible cause:

The coolant temperature is too high.

- If possible, ride in the part-load range to cool down the engine.
- If the coolant temperature is frequently too high, have the fault rectified as soon as possible by a specialist workshop, preferably an authorised BMW Motorrad dealer.

Emissions warning



The malfunction indicator lamp lights up.



Exhaust re-treatment impaired. Have it checked by a specialist workshop.

Possible cause:

The engine control unit has diagnosed a fault which affects the pollutant emissions.

- Have the fault rectified by a specialist workshop, preferably an authorised BMW Motorrad dealer.
- » You can continue riding; pollutant emissions are higher than the threshold values.

Engine control failed





General warning light shows yellow.



Engine control failure! Multiple sys. affected. Ride carefully to the next specialist workshop.

Engine in emergency-operation mode

 General warning light shows yellow.

 Fault in the engine control. Onward journey possible. Ride carefully to next specialist workshop.

WARNING**Unusual ride characteristics when engine running in emergency-operation mode**

Risk of accident

- Adapt your style of riding accordingly: avoid accelerating sharply and overtaking.◀

Possible cause:

The engine control unit has diagnosed a fault which impairs the engine performance or throttle response. The engine is

in emergency-operation mode. In exceptional cases, the engine stops and refuses to start.

- Have the fault rectified as quickly as possible by a specialist workshop, preferably an authorised BMW Motorrad dealer.
- » It is possible to continue riding, however the engine performance and engine speed range may be impaired and not function as normal.

Severe fault in the engine control

 General warning light flashes yellow.

 Serious fault in the engine control! Onward journey possible. Engine damage possible. Have checked by workshop.

WARNING**Engine damage when running in emergency-operation mode**

Risk of accident

- Adapt your style of riding accordingly: ride slowly, avoid sharp accelerating and overtaking.
- If possible, have the vehicle brought in and the fault rectified by a specialist workshop, preferably an authorised BMW Motorrad dealer.◀

Possible cause:

The engine control unit has diagnosed a fault which may cause severe secondary faults. The engine is in emergency-operation mode.

- It is possible to continue to ride but not recommended.

- Avoid high load and rpm ranges if possible.
- Have the fault rectified as quickly as possible by a specialist workshop, preferably an authorised BMW Motorrad dealer.

Tyre pressure

– with tyre pressure control (RDC)^{OE}

In addition to the MY VEHICLE and check control messages menu screens, there is the TYRE PRESSURE screen to display the tyre pressure:



The values on the left refer to the front wheel and the values on the right to the rear wheel. The difference between the actual and target tyre pressures is displayed. Immediately after the ignition is switched on, only dashes are displayed. The transmission of the tyre pressure value begins only once the following minimum speeds have been exceeded:

 RDC sensor is not active

min 30 km/h (The RDC sensor does not transmit its signal to the vehicle until a certain minimum speed has been reached.)

 The tyre pressures are shown in the multifunction display as compensating for the temperature and always refer to the following tyre air temperature:

20 °C

 If the tyre symbol is also displayed in yellow or red, this is a warning. The pressure difference is highlighted with an exclamation mark in the same colour.

 If the value in question is close to the limit of the permissible tolerance range, the reading is accompanied by the 'General' warning light showing yellow.

 If the tyre pressure registered by the sensor is outside the permissible tolerance range, the 'General' warning light flashes red.

For more information on BMW Motorrad tyre pressure control, see the "Engineering details" section from page (►► 155).

Tyre pressure in limit range of the permitted tolerance

– with tyre pressure control (RDC)^{OE}

 General warning light shows yellow.

 is displayed in yellow.

 Tyre pressure does not match setpoint Check tyre pressure.

Possible cause:

Measured tyre pressure is close to the limit of permitted tolerance.

- Correct tyre pressure.
- Before adjusting the tyre pressure, observe the information on temperature compensation and pressure adaptation in the section entitled "Engineering details":
 - » Temperature compensation (►► 155)
 - » Pressure adaptation (►► 156)
 - » Find the correct tyre pressures in the following places:

- On the back cover of the Rider's Manual
- Instrument cluster in the TYRE PRESSURE view
- Sign under the seat

Tyre pressure outside the permitted tolerance

– with tyre pressure control (RDC)^{OE}

 General warning light flashes red.

 is displayed in red.

 Tyre pressure does not match setpoint Stop immediately! Check tyre pressure.

 Tyre pressure control. Loss of pressure. Stop immediately! Check tyre pressure.

 **WARNING**

Tyre pressure outside permitted tolerance.

Impairment of the vehicle's handling characteristics.

- Adapt your style of riding accordingly. ◀

Possible cause:

Measured tyre pressure is outside permitted tolerance.

- Check the tyre for damage and to ascertain whether the vehicle can be ridden with the tyre in its present condition.

If the vehicle can be ridden with the tyre in its present condition:

- Correct the tyre pressure at the earliest possible opportunity.
- Before adjusting the tyre pressure, observe the information on temperature compensation and pressure adaptation in the section entitled "Engineering details":

- » Temperature compensation (►► 155)
- » Pressure adaptation (►► 156)
- » Find the correct tyre pressures in the following places:
 - On the back cover of the Rider's Manual
 - Instrument cluster in the TYRE PRESSURE view
 - Sign under the seat
- Have the tyre checked for damage by a specialist workshop, preferably an authorised BMW Motorrad dealer.

 **NOTICE**

You can deactivate RDC warnings for riding in off-road mode. ◀

If you are unsure whether the vehicle can be ridden with the tyre in its present condition:

- Do not continue your journey.
- Notify the breakdown service.

Transmission fault

– with tyre pressure control (RDC)^{OE}

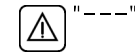

Possible cause:

The vehicle did not reach the minimum required speed (►► 155).

 RDC sensor is not active

min 30 km/h (The RDC sensor does not transmit its signal to the vehicle until a certain minimum speed has been reached.)

- Increase speed above this threshold and observe the RDC readings. Assume that a permanent fault has not occurred unless the 'General' warning light comes on to accompany

the symptoms. Under these circumstances:

- Have the fault rectified by a specialist workshop, preferably an authorised BMW Motorrad dealer.

Possible cause:

Wireless communication with the RDC sensors has been disrupted.

Possible causes include radio-communication systems operating in the vicinity and interfering with the link between the RDC control unit and the sensors.

- Move to another location and observe the RDC readings. Assume that a permanent fault has not occurred unless the 'General' warning light comes on to accompany the symptoms. Under these circumstances:
- Have the fault rectified by a specialist workshop, preferably

an authorised BMW Motorrad dealer.

Sensor faulty or system fault

– with tyre pressure control (RDC)^{OE}



General warning light shows yellow.



"----"

Possible cause:

Vehicle is fitted with wheels not equipped with RDC sensors.

- Fit wheels and tyres equipped with RDC sensors.

Possible cause:

1 or 2 RDC sensors have failed or a system error has occurred.

- Have the fault rectified by a specialist workshop, preferably an authorised BMW Motorrad dealer.

Battery for tyre pressure sensor weak

– with tyre pressure control (RDC)^{OE}



General warning light shows yellow.



RDC sensor battery weak. Function limited. Have it checked by a specialist workshop.



NOTICE

This error message shows briefly only after the Pre-Ride-Check completes. ◀

Possible cause:

The integral battery in the tyre-pressure sensor has lost a significant proportion of its original capacity. There is no assurance of how long the tyre pressure

control system can remain operational.

- Seek the advice of a specialist workshop, preferably an authorised BMW Motorrad dealer.

Drop sensor defective

 Drop sensor faulty. Have it checked by a specialist workshop.

Possible cause:

- The drop sensor is not available.
- Seek the advice of a specialist workshop, preferably an authorised BMW Motorrad dealer.

Emergency call function restricted

 Emergency call failure. Make an appointment at a specialist workshop.

Possible cause:

The emergency call cannot be made automatically or via BMW.

- Find information on operating the intelligent emergency call from page (➔ 63).
- Seek the advice of a specialist workshop, preferably an authorised BMW Motorrad dealer.

Side stand monitoring is faulty

 Side stand monitoring faulty. To avoid breakdown do not stop engine. Have checked by spec. workshop.

Possible cause:

The side-stand switch or its wiring are damaged.

- Seek the advice of a specialist workshop, preferably an authorised BMW Motorrad dealer.

ABS self-diagnosis not completed

 ABS telltale and warning light flashes.

Possible cause:

 ABS self-diagnosis not completed

The ABS function is not available, because self-diagnosis did not complete. (The motorcycle has to reach a defined minimum speed for the wheel speed sensors to be checked: 5 km/h)

- Pull away slowly. Bear in mind that the ABS function is not available until self-diagnosis has completed.

ABS deactivated

 ABS indicator and warning light shows.



Off!



ABS deactivated.

Possible cause:

The rider has switched off the ABS system.

- Activating the ABS function (► 71).

ABS fault



ABS indicator and warning light shows.



Limited ABS availability!

Onward journey possible. Ride carefully to next specialist workshop.

Possible cause:

The ABS control unit has detected a fault. The partial integral brake has failed. The ABS function is restricted.

- You can continue to ride. Pay attention to the more detailed information on certain situations that can lead to an ABS fault message (► 147).
- Have the fault rectified as quickly as possible by a specialist workshop, preferably an authorised BMW Motorrad dealer.

ABS failed



ABS indicator and warning light shows.



ABS failure!
Onward journey possible. Ride carefully to next specialist workshop.

Possible cause:

The ABS control unit has detected a fault. The ABS function is not available.

- You can continue to ride. Pay attention to the more detailed

information on certain situations that can lead to an ABS fault message (► 147).

- Have the fault rectified as quickly as possible by a specialist workshop, preferably an authorised BMW Motorrad dealer.

ABS Pro failed

– with riding modes Pro^{OE}



ABS indicator and warning light shows.



ABS Pro failure!
Onward journey possible. Ride carefully to next specialist workshop.

Possible cause:

The ABS Pro control unit has detected a fault. The ABS Pro function is not available. The ABS function is still available.

ABS provides support only for braking in straight-ahead driving.

- You can continue to ride. Bear in mind the more detailed information on certain situations that can lead to an ABS Pro fault message (► 147).
- Have the fault rectified as quickly as possible by a specialist workshop, preferably an authorised BMW Motorrad dealer.

ASC intervention

– without riding modes Pro^{OE}

 ASC indicator and warning light flashing quickly. The ASC has detected a degree of instability at the rear wheel and has intervened to reduce torque. The warning light flashes for longer than the ASC intervention lasts. This affords the rider visual feedback on control

intervention even after the critical situation has been dealt with.

ASC self-diagnosis not completed

– without riding modes Pro^{OE}

 ASC indicator and warning light flashing slowly.

Possible cause:

 ASC self-diagnosis not completed

The ASC function is not available, because self-diagnosis did not complete. (The motorcycle has to reach a defined minimum speed for the wheel sensors to be checked: min 5 km/h)

- Pull away slowly. The ASC indicator and warning light goes out after a few minutes.

The ASC indicator and warning light continues to flash:

- Seek the advice of a specialist workshop, preferably an authorised BMW Motorrad dealer,

ASC switched off

 ASC indicator and warning light shows.

 Off!

 Traction control deactivated.

Possible cause:

The rider has switched off the ASC system.

- without riding modes Pro^{OE}
- Activating the ASC function (► 72).

ASC fault

 ASC indicator and warning light shows.

 Traction control failure! Onward journey possible.

Ride carefully to next specialist workshop.

Possible cause:

The DSC control unit has detected a fault. The ASC function is no longer available.

- You can continue to ride. Bear in mind that the ASC function is not available. Pay attention to the more detailed information on situations that can lead to an ASC fault (► 150).
- Have the fault rectified as quickly as possible by a specialist workshop, preferably an authorised BMW Motorrad dealer.

DTC intervention

– with riding modes Pro^{OE}



DTC indicator and warning light flashes quickly.

The DTC has detected a degree of instability at the rear wheel

and has intervened to reduce torque. The indicator and warning light flashes longer than the DTC intervention lasts. This affords the rider visual feedback on control intervention even after the critical situation has been dealt with.

DTC self-diagnosis not completed

– with riding modes Pro^{OE}



DTC indicator and warning light flashes slowly.

Possible cause:



DTC self-diagnosis not completed

The DTC function is not available, because self-diagnosis did not complete. (The motorcycle has to reach a defined minimum speed with the engine running for the wheel-speed sensors to be checked: min 5 km/h)

- Pull away slowly. Bear in mind that the DTC function is not available until self-diagnosis has completed.

DTC switched off

– with riding modes Pro^{OE}



DTC indicator and warning light shows.



Off!

 Traction control deactivated.

Possible cause:

The rider has switched off the DTC system.

- DTC Switching on (➔ 74).

DTC fault

– with riding modes Pro^{OE}

 DTC indicator and warning light shows.

 Traction control failure! Onward journey possible. Ride carefully to next specialist workshop.

Possible cause:

The DTC control unit has detected a fault.

 **ATTENTION**

Damaged components

Damage to sensors, for example, which causes malfunctions

- Do not transport any objects underneath the driver or passenger seat.
- Secure the toolkit.◀
- Do not damage the angular rate sensor.
- Bear in mind that the DTC function is not available or the functionality is subject to certain restrictions.
- You can continue to ride. Pay attention to the more detailed information on situations that can lead to a DTC fault (➔ 150).
- Have the fault rectified as quickly as possible by a specialist workshop, preferably an authorised BMW Motorrad dealer.

D-ESA fault

 General warning light shows yellow.

 Spring strut adjustment faulty! Onward journey possible. Ride carefully to next specialist workshop.

Possible cause:

The D-ESA control unit has detected a fault. The damping and/or spring adjuster may be the cause. In Auto the cause may also be a fault in the riding position equaliser. In this condition, the motorcycle may have too much damping and is uncomfortable to drive, especially on roads in poor condition. Alternatively, the spring preload may be incorrectly adjusted.

- Have the fault rectified as quickly as possible by a

specialist workshop, preferably an authorised BMW Motorrad dealer.

Fuel down to reserve



Tankreserve erreicht.
Demnächst Tankstelle anfahren.



Irregular engine operation or engine shutdown due to lack of fuel

Risk of accident, damage to catalytic converter

- Do not run the fuel tank dry. ◀

Possible cause:

The fuel tank contains no more than the reserve quantity of fuel.



Reserve fuel

approx. 4 l

- Refuelling (►► 138).

Hill Start Control activated

– with riding modes Pro^{OE}



The holding symbol is displayed.

Possible cause:

The driver has activated Hill Start Control (►► 157).

- Switch off Hill Start Control.
- Operate Hill Start Control (►► 84).

Hill Start Control is deactivated automatically

– with riding modes Pro^{OE}



General warning light flashes yellow.



The holding symbol flashes briefly.

Possible cause:

Hill Start Control has been switched off automatically.

- The side stands have been folded out.
- » Hill Start Control is deactivated when the side stands are folded out.
- The engine has been stopped.
- » Hill Start Control is deactivated when the engine is stopped.
- The motorcycle has been driven off with Hill Start Control activated.
- Operate Hill Start Control (►► 84).

Hill Start Control cannot be activated

– with riding modes Pro^{OE}



General warning light flashes yellow.

 The holding symbol flashes briefly.

Possible cause:

Hill Start Control cannot be activated.

- Retract the side stand.
- » Hill Start Control functions only when the side stands are folded in.
- Start the engine.
- » Hill Start Control functions only when the engine is running.

Gear not trained

– with shift assistant Pro^{OE}

 The gear indicator flashes. The Pro shift assistant is not available.

Possible cause:

– with shift assistant Pro^{OE}

The gearbox sensor is not fully trained.

- Engage neutral gear N and, with the vehicle at a standstill, let the engine run for at least

10 seconds to train the idle gear.

- Engage all gears with clutch actuation and ride at least 10 seconds with the engaged gear.
 - » The gear indicator starts to flash when the gearbox sensor has been trained successfully.
- When the gearbox sensor is fully trained, the Pro shift assistant functions as described (► 156).
- If the training process was not successful, have the fault rectified by a specialist workshop, preferably an authorised BMW Motorrad dealer.

Hazard warning lights system is switched on

 Turn signal indicator light flashes green.

 Turn signal indicator light flashes green.

Possible cause:

The driver has switched on the hazard warning lights system.

- Operating hazard warning flashers (► 69).

Service-due indicator

 If service is overdue, the due date or the odometer reading at which service was due is accompanied by the 'General' warning light showing yellow.

If the service is overdue, a yellow CC message is displayed. Exclamation marks also draw your attention to the displays for service, service appointment and remaining distance in the MY VEHICLE and SERVICE REQUIREMENTS menu screens.

NOTICE

If the service-due indicator appears more than a month before the service date, the current date has to be corrected. This situation can occur if the battery was disconnected.◀

Service due

 is displayed in white.

Service due! Have service carried out by a BMW Motorrad Retailer.

Possible cause:

Service is due because of the driving performance or the date.

- Have your motorcycle serviced regularly by a specialist workshop, preferably by an authorised BMW Motorrad retailer.

- » The operational and road safety of the motorcycle remain intact.
- » The motorcycle's value is maintained as best as possible.

Service-due date has passed

 General warning light shows yellow.

 is displayed in yellow.

Service overdue! Have service carried out by a BMW Motorrad Retailer.

Possible cause:

Service is overdue because of the driving performance or the date.

- Have your motorcycle serviced regularly by a specialist workshop, preferably by an authorised BMW Motorrad retailer.

- » The operational and road safety of the motorcycle remain intact.
- » The motorcycle's value is maintained as best as possible.

Operation

Ignition switch/steering lock	56	Cruise-control system	81
Ignition with Keyless Ride	58	Hill Start Control	84
Emergency off switch (kill switch)	62	Anti-theft alarm (DWA)	85
Intelligent emergency call	63	Tyre pressure monitoring (RDC)	88
Lights	65	Heated handlebar grips	88
Daytime riding light	67	On-board computer	89
Hazard warning lights system	69	Front and rear seats	90
Turn indicators	69	Stowage compartment	92
Anti-lock brake system (ABS)	70	5 V charger interface	93
Automatic Stability Control (ASC)	72		
Dynamic Traction Control (DTC)	73		
Electronic Suspension Adjustment (D-ESA)	75		
Riding mode	78		

Ignition switch/steering lock

Keys

You receive 2 ignition keys. Please consult the information on the electronic immobiliser (EWS) if a key is lost or mislaid (► 57). Ignition switch/steering lock, fuel filler cap lock and seat lock are all operated with the same key.

If you wish you can arrange to have the cases and the top-case fitted with locks that can be opened with the ignition key as well. Consult a specialist workshop, preferably an authorised BMW Motorrad dealer.

Lock the handlebars

- Turn the handlebars all the way to left.

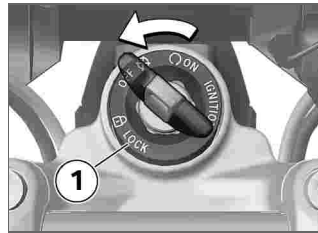

- Turn the key to position **1**, while moving the handlebars slightly.
 - » Ignition, lights and all function circuits switched off.
 - » Handlebars are locked.
 - » Key can be removed.

Switching on ignition

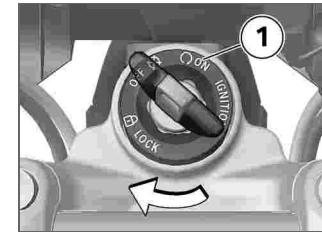

- Insert the key in the ignition switch and turn to position **1**.
 - » Side lights and all function circuits are switched on.
 - » Pre-Ride-Check is performed. (► 130)
 - » ABS self-diagnosis is in progress. (► 130)
 - without riding modes Pro^{OE}
 - » ASC self-diagnosis is performed. (► 131)<
 - with riding modes Pro^{OE}
 - » DTC self-diagnosis is in progress. (► 132)<

Welcome lights

- Switch on the ignition.
 - » The side lights briefly light up.
 - with daytime riding light^{OE}
 - » The daytime riding lights briefly light up.<
 - with LED headlight^{OE}
 - » The LED auxiliary headlights briefly light up.<

Switching off ignition

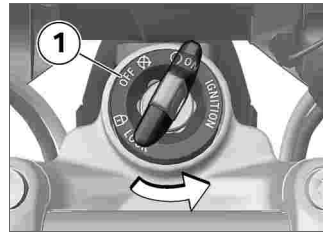

- Turn the ignition key to position **1**.
 - » When the ignition is switched off, the instrument cluster remains switched on for a short

- time and displays any existing fault messages.
 - » Handlebars not locked.
 - » Electrically powered accessories remain operational for a limited period of time.
 - » The battery can be recharged via the socket.
 - » Key can be removed.

- with daytime riding light^{OE}
- with LED headlight^{OE}
- The daytime riding light goes out soon after the ignition is switched off.<
- with LED auxiliary headlights^{OA}
- The LED auxiliary headlights go out soon after the ignition is switched off.<

Electronic immobiliser EWS

The electronic design of the motorcycle allows it to access data stored in the ignition key by means of a ring antenna located in the ignition switch/steering lock. The engine control unit will not permit the engine to be started unless the key is identified as "authorised".

NOTICE

A spare key attached to the same ring as the ignition key used to start the engine could "irritate" the electronics, in which case the enabling signal for starting is not issued. Always keep the spare key separately from the ignition key.<

If you lose your key, you can have it barred by your authorised BMW Motorrad dealer. If you wish to do this, you will need to bring all other keys for the motorcycle with you. The engine cannot be started by a barred key, but a key that has been barred can subsequently be reactivated. You can obtain emergency/extra keys only through an authorised BMW Motorrad dealer. The keys are part of an integrated security system, so the dealer is under an obligation to check the legitimacy of all applications for replacement/extra keys.

Ignition with Keyless Ride

– with Keyless Ride^{OE}

Keys

NOTICE

The telltale light for the radio-operated key flashes while the search for the radio-operated key is in progress.

The telltale light goes out as soon as the radio-operated key or the emergency key is found. The telltale light goes out briefly if the search times out without the radio-operated key or the emergency key being found.◀

You receive one radio-operated key and one emergency key. Please consult the information on the electronic immobiliser (EWS) if a key is lost or mislaid (► 57). Ignition, fuel filler cap and anti-theft alarm system all work with the radio-operated key. Seat lock, topcase and cases can be locked and unlocked manually.

NOTICE

The vehicle cannot be started if the radio control key is not within range (e.g. key inside one of the cases or the topcase). If the radio-operated key remains out of range the ignition is switched off after about 1.5 minutes to protect the battery. It is advisable to keep the radio-operated key on your person (e.g. in a jacket pocket) and to have the emergency key with you as an alternative.◀

	Range of the Keyless Ride radio-operated key
– with Keyless Ride ^{OE}	
approx. 1 m◀	

Lock the handlebars

Requirement

The handlebars are turned towards the left. Radio-operated key is within range.

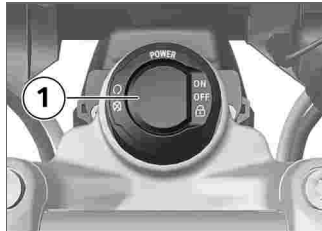

- Press and hold down button **1**.
 - » The steering lock engages with an audible click.
 - » Ignition, lights and all function circuits switched off.
- To unlock the steering lock, briefly press button **1**.

Switching on ignition

Requirement

Radio-operated key is within range.

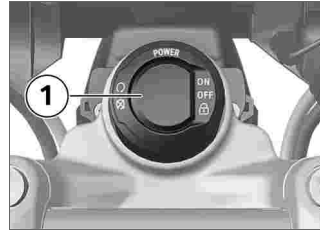

- There are **two** ways of activating the ignition.

Version 1:

- Briefly press button **1**.
 - » Side lights and all function circuits are switched on.
 - with daytime riding light^{OE}
 - » Daytime riding light is switched on.<

- with LED headlight^{OE}
 - » LED auxiliary headlights are switched on.<
 - » Pre-Ride-Check is performed. (►► 130)
 - » ABS self-diagnosis is in progress. (►► 130)
- without riding modes Pro^{OE}
 - » ASC self-diagnosis is performed. (►► 131)<
- with riding modes Pro^{OE}
 - » DTC self-diagnosis is in progress. (►► 132)<

Version 2:

- Steering lock is engaged; press and hold down button **1**.
 - » The steering lock disengages.
 - » Parking lights and all function circuits switched on.
 - » Pre-Ride-Check is performed. (►► 130)
 - » ABS self-diagnosis is in progress. (►► 130)

- without riding modes Pro^{OE}
 - » ASC self-diagnosis is performed. (► 131)◀
- with riding modes Pro^{OE}
 - » DTC self-diagnosis is in progress. (► 132)◀

Switching off ignition Requirement

Radio-operated key is within range.

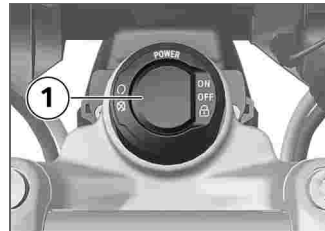

- There are **two** ways of deactivating the ignition.

Version 1:

- Briefly press button **1**.
- » Light is switched off.
- » Handlebars (steering lock) are not locked.

Version 2:

- Turn the handlebars all the way to left.
- Press and hold down button **1**.
- » Light is switched off.
- » The steering lock engages.

Electronic immobiliser EWS

The on-board electronics access the data saved in the radio-operated key via a ring aerial in the wireless lock. The ignition is not enabled for starting until the engine control unit has recognised the radio-operated key as "authorised" for your motorcycle.

NOTICE

A spare key attached to the same ring as the radio-operated key used to start the engine could "irritate" the electronics, in which case the enabling signal for starting is not issued. Always keep the spare key separate from the radio-operated key.◀

If you mislay a radio-operated key you can have the key in question barred by your authorised BMW Motorrad dealer. In order to have a key barred you must bring along all the other keys belonging to the motorcycle. The engine cannot be started by a barred radio-operated key, but a radio-operated key that has been barred can subsequently be reactivated.

You can obtain emergency/extra keys only through an author-

ised BMW Motorrad dealer. The radio-operated keys are part of an integrated security system, so the dealer is under an obligation to check the legitimacy of all applications for replacement/extra keys.

Battery of the radio-operated key is empty or loss of the radio-operated key

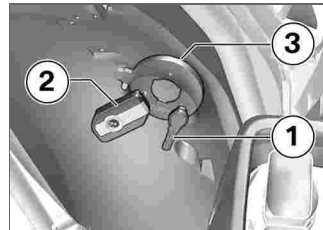

- Please consult the information on the electronic immobiliser (EWS) if a key is lost or mislaid.

- If you happen to lose or mislay the radio-operated key while on a journey, you can start the vehicle with the emergency key.
- If the battery of the radio-operated key is empty, touching the radio-operated key against the rear-wheel cover will start the engine.
- Hold emergency key **1** or radio-operated key with empty battery **2** at the rear-wheel cover level with aerial **3**.

NOTICE

The emergency key or the radio-operated key with the empty battery must be **in contact with** the rear-wheel cover.◀

 Time during which the engine has to be started. The unlocking procedure has to be repeated if this time is allowed to expire.

30 s

- » Pre-ride check is performed.
- Key has been recognised.
- Engine can be started.
- Starting the engine (► 129).

Replace the battery of the radio-operated key

If the radio-operated key does not react when you short-press or long-press a button:

- The battery in the radio-operated key is not at full capacity.

 Remote key battery weak. Limited central locking function. Change battery.

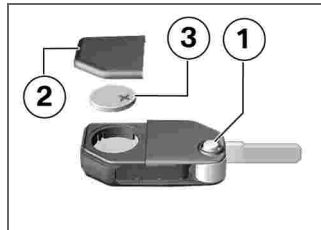

- Press button **1**.
 - » Key bit flips out.
- Push up battery cover **2**.
- Remove the battery **3**.
- Dispose of the old battery in accordance with all applicable laws and regulations; do not attempt to dispose of batteries as domestic waste.

ATTENTION

Unsuitable or incorrectly inserted batteries

Component damage

- Use a battery compliant with the manufacturer's specifications.
- When inserting the battery, always make sure polarity is correct.◀
- Insert the new battery with the positive terminal up.



Battery type

for Keyless Ride-radio-operated key

CR 2032

- Remove the battery **2**.
 - » Red LED on the instrument panel flashes.
 - » The radio-operated key is ready for use again.

Emergency off switch (kill switch)

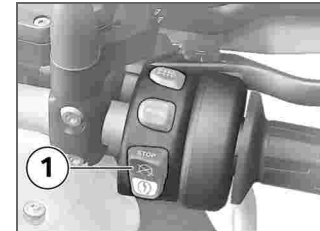

- 1** Emergency off switch (kill switch)

WARNING

Operation of the kill switch while riding

Risk of fall due to rear wheel locking

- Do not operate the kill switch when riding.◀

The emergency off switch is a kill switch for switching off the engine quickly and easily,

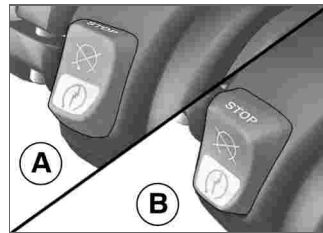

- A Engine switched off
- B Normal operating position (run)

Intelligent emergency call

– with intelligent emergency call^{OE}

Emergency call via BMW

Press the SOS button in an emergency only.

Even if an emergency call using BMW is not possible, the system may make an emergency call to a public emergency call number. This depends on the respective mobile phone network and the national regulations.

The emergency call is not able to be ensured because of technical reasons due to unfavourable conditions, e.g. in areas where there is no mobile phone reception.

Language for emergency call

Each vehicle has a language assigned to it depending on the market for which it is intended. The BMW Call Center answers in this language.

NOTICE

A changeover of the language for the emergency call can only be performed by the BMW Motorrad partner. The language assigned to the vehicle varies from the selectable language the driver can choose as the display language in the TFT display.◀

Manual emergency call Requirement

An emergency call has occurred. The vehicle is at a standstill. The ignition is switched on.

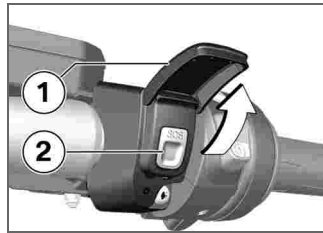

- Open cover **1**.
- Briefly press SOS button **2**.



The time until transmission of an emergency call is displayed. During that time, it is possible to cancel the emergency call.

- Operate the emergency-off switch to stop the engine.
- Remove helmet.
- » After expiry of the timer, a voice contact to the BMW Call Center is established.



The connection was established.

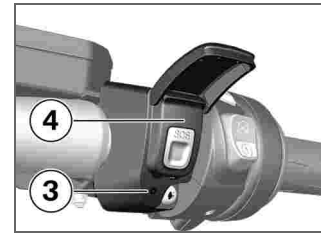

- Provide information to the emergency services using the microphone **3** and speaker **4**.

Automatic emergency call

The intelligent emergency call is active after the ignition is switched on and reacts if a fall or crash occurs.

Emergency call in the event of a light fall

- A minor fall or a crash is detected.
- » An acoustic signal is sounded.



The time until transmission of an emergency call is displayed. During that time, it is possible to cancel the emergency call.

- If possible, remove helmet and stop engine.
- » A voice contact connection to the BMW Call Center is established.



The connection was established.

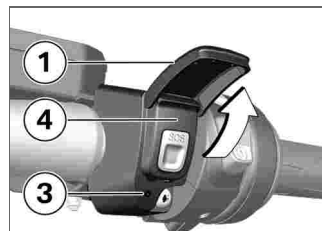

- Open cover **1**.
- Provide information to the emergency services using the microphone **3** and speaker **4**.

Emergency call in the event of a severe fall

- A severe fall or a crash is detected.
- » The emergency call is placed automatically without delay.

Lights

Low-beam headlight and sidelights

The side lights switch on automatically when the ignition is switched on.

NOTICE

The side lights place a strain on the battery. Do not switch the ignition on for longer than absolutely necessary.◀

The low-beam headlight switches on automatically when the engine is started.

– with daytime riding light^{OE}
 In daytime the daytime riding light can be switched on as an alternative to the low-beam headlight.

High-beam headlight and headlight flasher

- Switching on ignition (▮▮▮ 56).

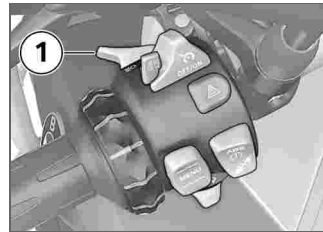

- Push switch **1** forward to switch on the high-beam headlight.
- Pull switch **1** back to operate the headlight flasher.

Headlight courtesy delay feature

- Switch off the ignition.

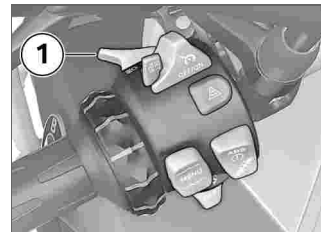

- Immediately after switching off the ignition, pull switch **1** back and hold it in that position until the headlight courtesy delay feature comes on.
- The vehicle lighting lights for one minute and is automatically switched back off.
- This can be used after parking the vehicle, for example, to light the way to the house door.

Parking lights

- Switching off ignition (▮▮▮ 57).



- Immediately after switching off the ignition, push button **1** to the left and hold it in that position until the parking lights come on.
- Switch the ignition on and off again to switch off the parking lights.

Auxiliary headlights

- with LED auxiliary headlights^{OA}

Requirement

The additional headlights are active only when the low-beam headlight is active.

NOTICE

The auxiliary headlights have approval as fog lights and their use is permissible in bad weather conditions only. Always comply with the road traffic regulations in force in the country in which the vehicle is used.◀

- Starting the engine (▶▶ 129).



- Press button **1** to switch on the additional headlights.
-  The indicator light for the auxiliary headlight illuminates.
- Press button **1** again to switch off the additional headlights.

Daytime riding light

– with daytime riding light^{OE}

Manual daytime riding light

Requirement

Automatic daytime riding light is switched off.

WARNING

Activation of daytime riding light in the dark.

Poorer vision and oncoming traffic dazzled.

- Do not use the daytime running light when it is dark.◀

NOTICE

By comparison with the low-beam headlight, the daytime running light makes the vehicle more visible to oncoming traffic. This improves daytime visibility.◀

- Starting the engine (▶▶ 129).
- In the **Settings**,
Vehicle settings,

4

67

Operation

Lights menu, switch off the Auto. daytime light function.



- Press button **1** to switch on the daytime riding light.

 The indicator light for the daytime riding light lights up.

- » The low-beam headlight and the front side lights are switched off.
- In the dark or in tunnels: Press button **1** again to switch off the daytime riding light and switch

on the low-beam headlight and front side light.

NOTICE

If the high-beam headlight is switched on while the daytime riding light is on, the daytime riding light is switched off after approx. 2 seconds and the high-beam headlight, low-beam headlight and front side light are switched on.

If the high beam headlight is switched off again, the daytime running light is not automatically reactivated, but must be switched on again if required.◀

Automatic daytime riding light

NOTICE

The changeover between daytime running light and low beam headlight including front

side lights can be effected automatically.◀

WARNING

The automatic riding light control system cannot replace your personal assessment of lighting conditions, particularly in foggy or misty weather.

Safety risk

- Manually switch on the low-beam headlight in poor lighting conditions.◀
- In the Settings, Vehicle settings, Lights menu, switch on the Auto. daytime light function.

 The indicator light for the automatic daytime riding light lights up.

- » If the ambient brightness decreases below a certain value,

the low beam headlight is automatically switched on (e. B. in a tunnel). When sufficient ambient brightness is detected, the daytime riding light is switched back on.

 The indicator light for the daytime riding light shows if the daytime riding light is active.

Manual operation of the light when the automatic system is switched on

- If you press the button for the daytime riding light the daytime riding light is switched off and the low-beam headlight and front side lights are switched on (e. g. when you ride into a tunnel, and the response of the automatic daytime riding light to the change in ambient brightness is delayed).
- If you press the button again the daytime riding light is re-activated, in other words the

daytime riding light is switched on again when ambient light is bright enough.

Hazard warning lights system

Operating hazard warning flashers

- Switching on ignition (→ 56).

NOTICE

The hazard warning flashers place a strain on the battery. Do not use the hazard warning flashers for longer than absolutely necessary.◀



- Press button **1** to switch on the hazard warning lights system.
 - » Ignition can be switched off.
- To switch off the hazard warning lights system, switch on the ignition if necessary and press button **1** again.

Turn indicators

Operating the turn indicators

- Switching on ignition (→ 56).



- Push button **1** to the left to switch on the left turn indicators.
- Push button **1** to the right to switch on the right turn indicators.
- Operate button **1** in centre position to cancel the turn indicators.



Turn indicator cancellation

The turn indicators are cancelled automatically after the defined riding time and distance.

Anti-lock brake system (ABS)

Deactivating the ABS function

- Switching on ignition (→ 56).

NOTICE

You have the option of deactivating the ABS function while the motorcycle is on the move. ◀



- Press and hold button **1** until the ABS indicator and warning light changes its status.

Immediately after the button **1** is pressed, the system statuses for ASCDTC and ABS are displayed as ON.

» Initially the ASC indicator and warning light changes status. Press and hold button **1** until the ABS indicator and warning light changes its status. In this case, the ASCDTC setting does not change.

 ABS indicator and warning light shows.

Possible ABS system status OFF ! is displayed.

- Release button **1** once the ABS system status has changed.

The ASCDTC system status remains unchanged and a new ABS system status OFF ! is briefly displayed.

 ABS indicator and warning light remains on.

- » The ABS function is switched off.
- » The integral function remains active.
 - with riding modes Pro^{OE}
- » Hill Start Control is still activated.<
- See the section entitled "Engineering details" for more information on brake systems with BMW Motorrad Integral ABS .
 - » Partially integral brakes (146)
 - with riding modes Pro^{OE}
 - » Hill Start Control function (157)<

Activating the ABS function



- Press and hold button **1** until the ABS indicator and warning light changes its status. Immediately after the button **1** is pressed, the system statuses for ASC/DTC and ABS are displayed as OFF !.

 ABS telltale and warning light goes out; if self-diagnosis has not completed, it starts flashing.

Possible ABS system status ON is displayed.

- Release button **1** once the ABS system status has changed.

 ABS indicator and warning light remains off or continues to flash.

The ASC/DTC system status remains unchanged and a new ABS system status ON is briefly displayed.

- » The ABS function is switched on.
- You also have the option of switching the ignition off and then on again.



An ABS fault has occurred if the ABS telltale and warning light shows when the motorcycle accelerates to a speed in excess of the minimum stated below after the ignition was switched off and then on again.

min 10 km/h

- with riding modes Pro^{OE}
- If the encoding plug is not inserted, you have the alternative of switching the ignition off and back on again.<

Automatic Stability Control (ASC)

Deactivating the ASC function

- without riding modes Pro^{OE}
- Switching on ignition (➡ 56).

NOTICE

You have the option of deactivating the ASC function while the motorcycle is on the move.<<



- Press and hold button **1** until the ASC indicator light changes its status.

Immediately after button **1** is pressed, ASC system status ON and current ABS system status are displayed.

ASC indicator and warning light shows.

Possible ABS system status OFF! is displayed.

- Release button **1** once the ASC system status has changed.

The new ASC system status OFF! is briefly displayed. The ABS system status remains unchanged.

ASC indicator and warning light remains on.

» The ASC function is switched off.

Activating the ASC function

- without riding modes Pro^{OE}



- Press and hold button **1** until the ASC indicator light changes its status.
Immediately after button **1** is pressed, ASC system status OFF! and current ABS system status are displayed.

 ASC indicator and warning light no longer lights up and starts flashing if the self-diagnosis is incomplete.

Possible ABS system status ON is displayed.

- Release button **1** once the status has changed.

 ASC indicator and warning light remains off or continues flashing.

The new ASC system status ON is briefly displayed. The ABS system status remains unchanged.

- » The ASC function is switched on.
- If the encoding plug is not inserted, you have the alternative of switching the ignition off and then on again.

NOTICE

See the section entitled "Engineering details" for more information on BMW Motorrad Automatic Stability Control (ASC).◀

 An ASC fault has occurred if the ASC indicator and warning light shows when the motorcycle accelerates to a speed in excess of the minimum stated below after the ignition was switched off and then on again.

min 5 km/h

- See the section entitled "Engineering details" for more information on Automatic Stability Control.
- » How does ASC work? (▶▶ 149)

Dynamic Traction Control (DTC)

– with riding modes Pro^{OE}

DTC Switching off

- Switch on the ignition.

NOTICE

You have the option of deactivating the DTC function while the motorcycle is on the move. ◀



- Press and hold button **1** until the DTC indicator light changes its status. Immediately after button **1** is pressed, DTC system status ON and current ABS system status are displayed.

 DTC indicator and warning light shows.

Possible DTC system status OFF! is displayed.

- Release button **1** once the status has changed. The new DTC system status OFF! is briefly displayed. The ABS system status remains unchanged.

 DTC indicator and warning light remains on.

» The DTC function is switched off.

DTC Switching on

- Press and hold button **1** until the DTC indicator light changes its status. Immediately after button **1** is pressed, DTC system status OFF! and current ABS system status are displayed.

 DTC indicator and warning light goes out; if self-diagnosis has not completed, it starts flashing.

Possible DTC system status ON is displayed.

- Release button **1** once the status has changed.
-  DTC indicator and warning light remains off or continues to flash.

The new DTC system status ON is briefly displayed. The ABS system status remains unchanged.

- » The DTC function is switched on.
- If the encoding plug is not inserted, you have the alternative of switching the ignition off and then on again.

 A DTC fault has occurred if the DTC telltale light shows when the motorcycle accelerates to a speed in excess of the minimum stated below after the ignition was switched off and then on again.

min 5 km/h

- See the section entitled "Engineering details" for more information on Dynamic Traction Control:
 - » How does traction control work? (►► 150)

Electronic Suspension Adjustment (D-ESA)

– with Dynamic ESA^{OE}

Dynamic ESA possible settings

The electronic chassis and suspension adjustment Dynamic ESA is able to adjust your motorcycle automatically to the load. If the spring preload is set to **Auto**, the rider does not have to change the load settings. See the "Engineering details" section for more information on Dynamic ESA (►► 152).

Available damping modes

- For on-road mode: Road and Dyna.
- For off-road mode: Enduro

Available load settings

- Fixed set minimum spring preload: Min
- Activated riding position equaliser with automatic adjustment of the spring preload: Auto
- Fixed set maximum spring preload: Max

Viewing suspension settings

- Switching on ignition (►► 56).



- Press button **1** briefly to view the current setting.

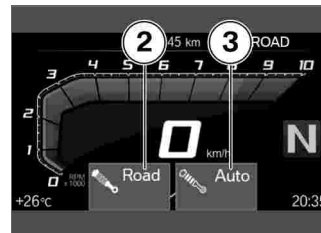

Immediately after button **1** is pressed, the chassis and suspension settings for damping action **2** and spring preload **3** are displayed.

» The setting shows briefly, then disappears automatically.

Adjusting the chassis and suspension

- Switching on ignition (►► 56).



- Press button **1** briefly to view the current setting.
- To adjust damping:
- Repeatedly press button **1** briefly until the setting you want to use appears on the display.

NOTICE

You can adjust the damping characteristic while the motorcycle is on the move.◀