

QUICK SETUP GUIDE

RF-TVMFM02

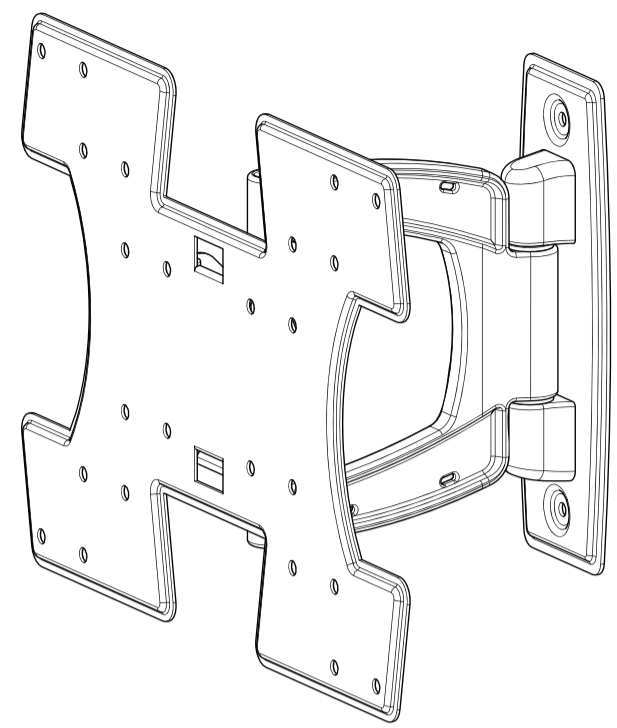

Thank you for choosing the Rocketfish RF-TVMFM02. The RF-TVMFM02 TV mount is designed to support a flat-panel TV weighing up to 60 lbs. (27.2 kg).

1 Install the TV bracket

Option 1: Installing for a flat mounting surface

- 1 Align the TV bracket (A) with the screw holes on the back of the TV.
- 2 Place the M4/M5 washers (H) or M6/M8 washers (O) over the holes in the TV bracket, then insert the M4 screws (F), M5 screws (J), or M6 screws (L or M) through the washers.
- 3 Tighten the screws until they are snug against the TV bracket. Do not over tighten.

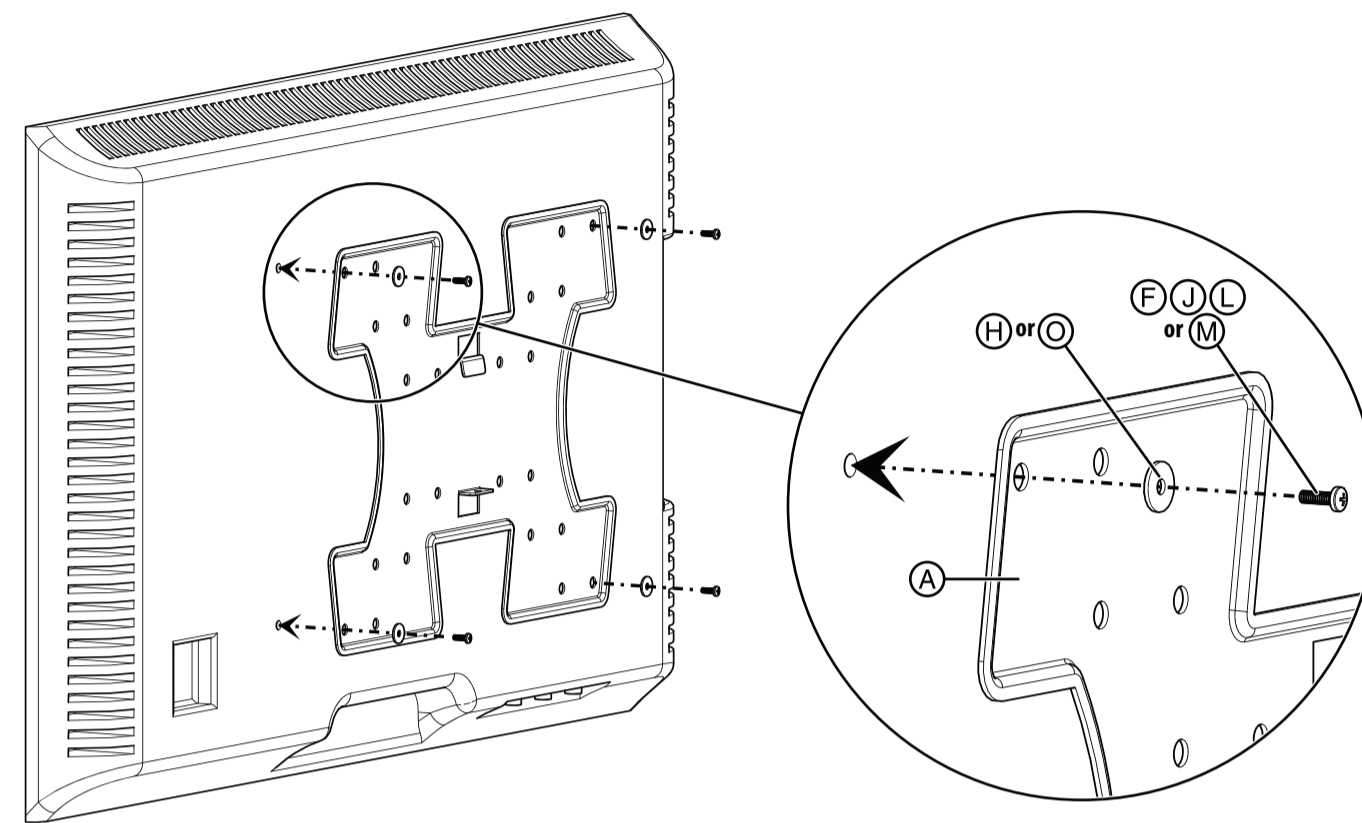

Option 2: Installing for an obstructed mounting surface

Note: Use additional washers (H) with M4/M5 hardware only.

- 1 Align the TV bracket (A) with the screw holes on the back of the TV.
- 2 Place the M4/M5 washers (H) or M6/M8 washers (O) over the holes in the TV bracket, then insert the M4 screws (G), M5 screws (K), or M6 screws (N or Q) through the washers.
- 3 Tighten the screws until they are snug against the TV bracket. Do not over tighten.

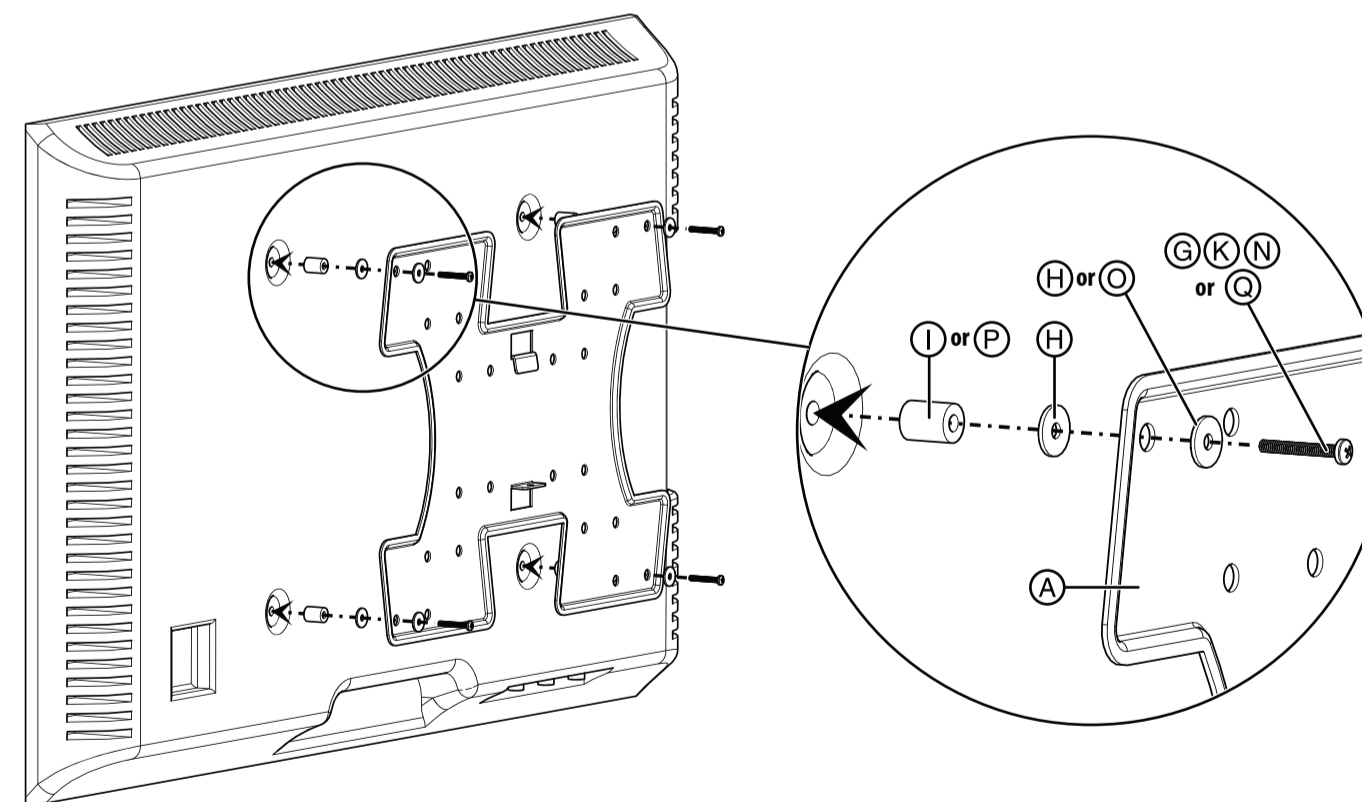

2 Install the arm assembly

Note: Any material covering the wall must not exceed 5/8 in. (16 mm).

Option 1: Installing to a wood stud wall

- 1 Locate the stud. Verify the center of the stud with an awl or thin nail or use an edge-to-edge stud finder.
- 2 Level the arm assembly (B) and mark the hole locations.
- 3 Drill pilot hole to a depth of 3 in. using a 7/32 in. diameter drill bit.
- 4 Align the arm assembly (B) with the pilot holes.
- 5 Place the washers (D) over the holes in the arm assembly, insert the lag bolts (E) through the washers, then tighten the lag bolts only until the washers are pulled firmly against the arm assembly.

CAUTION: Avoid potential injuries or property damage!
DO NOT over-tighten the lag bolts (E).

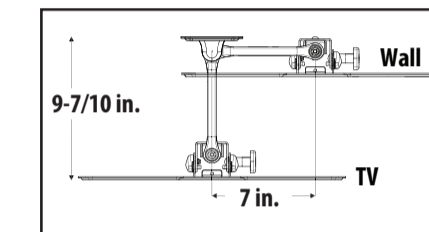

TV shifts 7 in. from the home position to full extension.

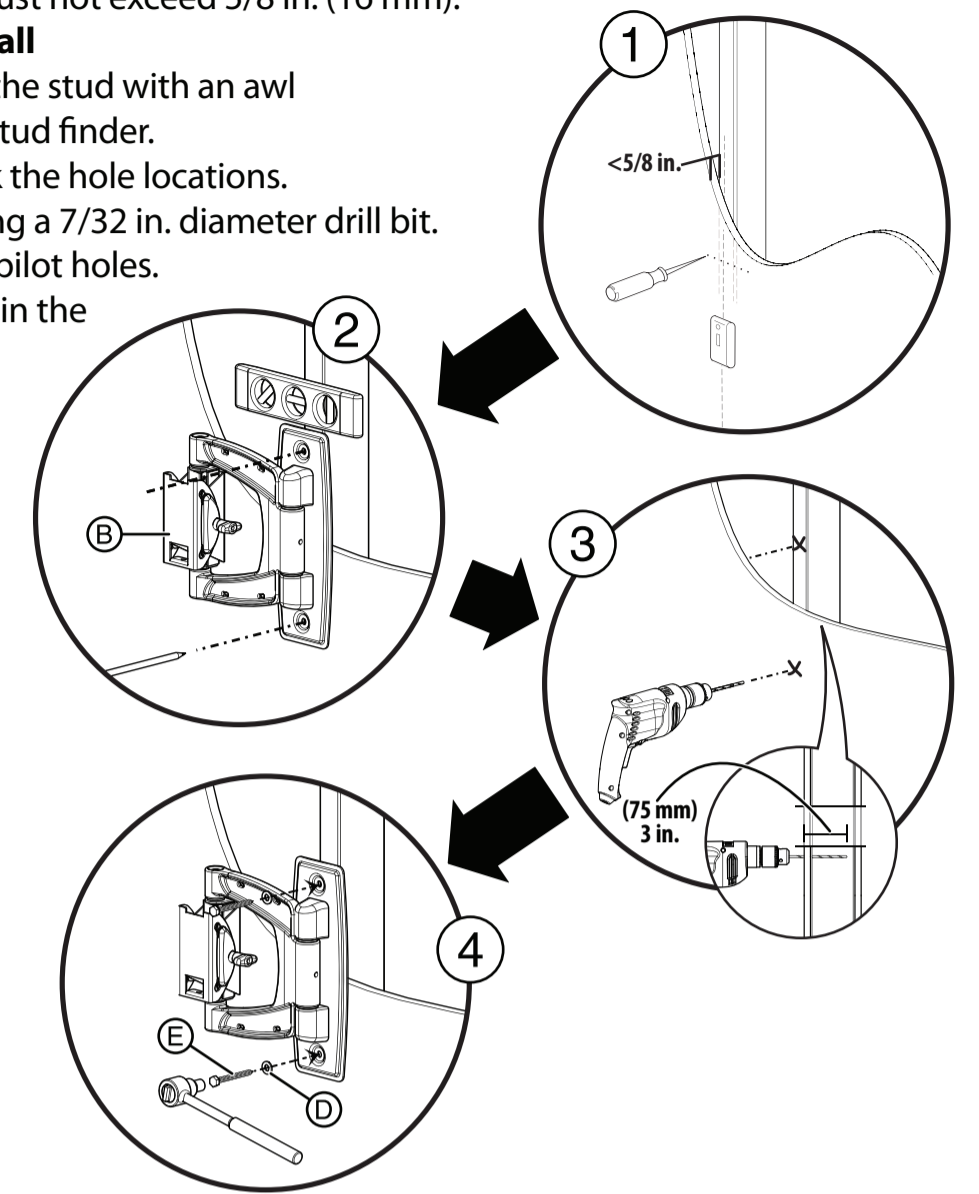

Option 2: Installing to a solid concrete or concrete block wall

- 1 Level the arm assembly (B) and mark the hole locations.
- 2 Drill pilot hole to a depth of 3 in. using a 3/8 in. diameter drill bit.
- 3 Insert the concrete wall anchors (C) into the pilot holes and make sure that the anchors are seated flush with the concrete surface.
- 4 Align the arm assembly (B) with the anchors.
- 5 Place the washers (D) over the holes in the arm assembly, insert the lag bolts (E) through the washers, then tighten the lag bolts only until the washers (D) are pulled firmly against the arm assembly.

CAUTION: Avoid potential injuries or property damage!
DO NOT over-tighten the lag bolts (E).

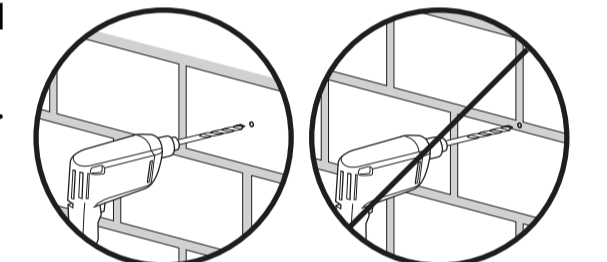

CAUTION: To prevent property damage or personal injury, never drill into mortar between blocks. Mount wall plate directly onto the concrete surface.

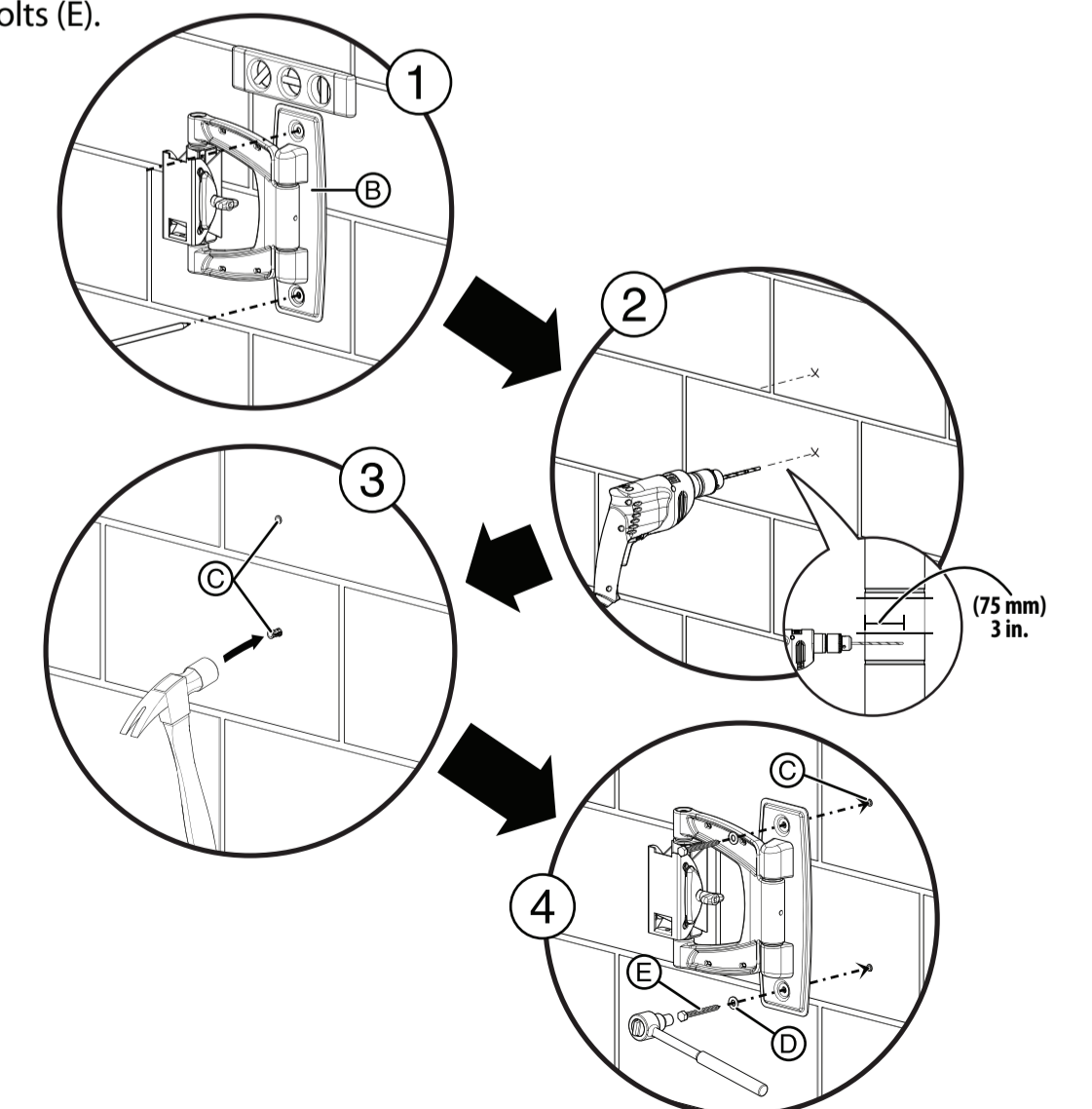

Package contents

- | | |
|--|-------------------------------------|
| A TV bracket (1) | M6 bag |
| B Arm assembly (1) | L M6 × 12 mm screws (4) |
| Lag bolt bag | M M6 × 20 mm screws (4) |
| C Concrete anchor (2) | N M6 × 35 mm screws (4) |
| D Lag bolt washer (2) | O M6/M8 washers (4) |
| E 5/16 in. × 2-3/4 in. lag bolt (2) | P M6/M8 spacers (4) |
| M4 bag | M8 bag |
| F M4 × 12 mm screws (4) | Q M8 × 40 mm screws (4) |
| G M4 × 30 mm screws (4) | Hex key bag |
| H M4/M5 washers (8) | R 3/16 in. hex key (1) |
| I M4/M5 spacers (4) | S 5/32 in. hex key (1) |
| M5 bag | Cap screw |
| J M5 × 12 mm screws (4) | T Cap screw (1) |
| K M5 × 30 mm screws (4) | Cable ties |
| | U 8 in. nylon cable ties (5) |

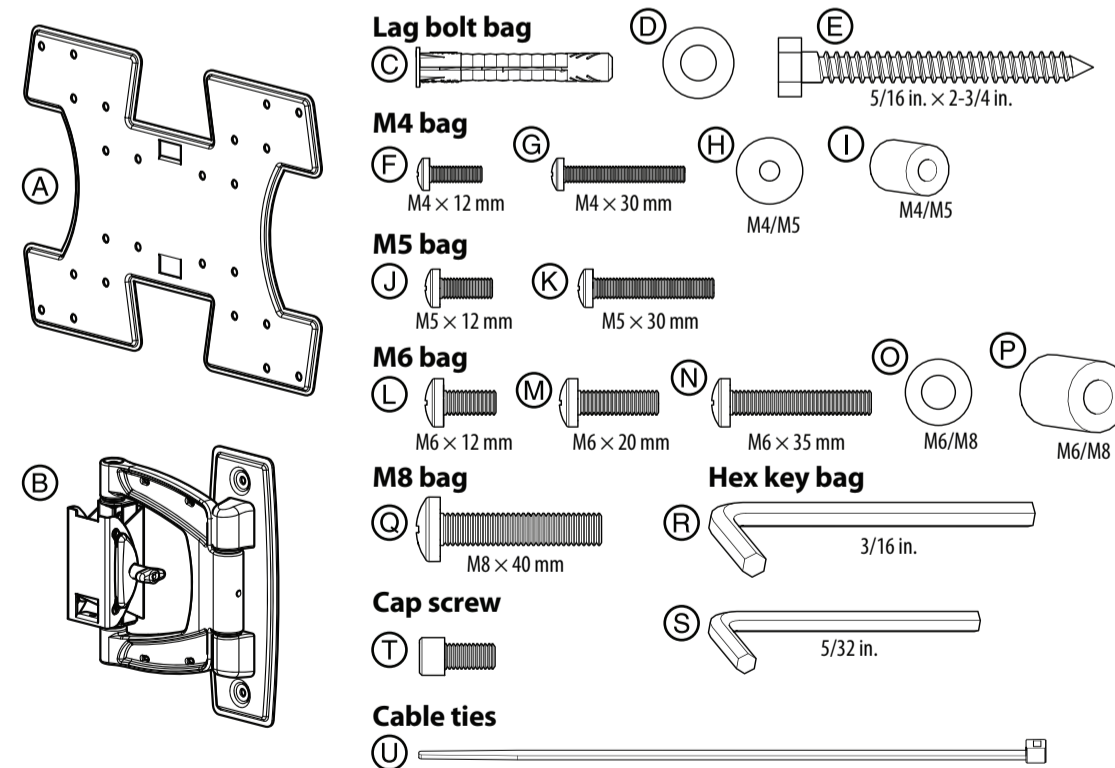

Tools you will need:

- Stud finder
- Awl
- Pencil
- Level
- Tape measure
- Phillips screwdriver
- Hammer (concrete only)
- Socket wrench with 1/2 in. socket or adjustable wrench
- 7/32 in. wood drill bit
- 3/8 in. masonry drill bit (concrete only)
- Power drill

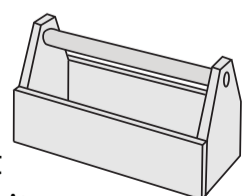

3 Mount the TV to the wall

- 1 Slide the top and bottom edges of the arm assembly under the metal tabs on the TV bracket.
- 2 Secure the arm assembly to the TV bracket with the cap screw (T) using the 3/16 in. hex key (R).

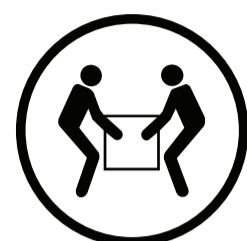
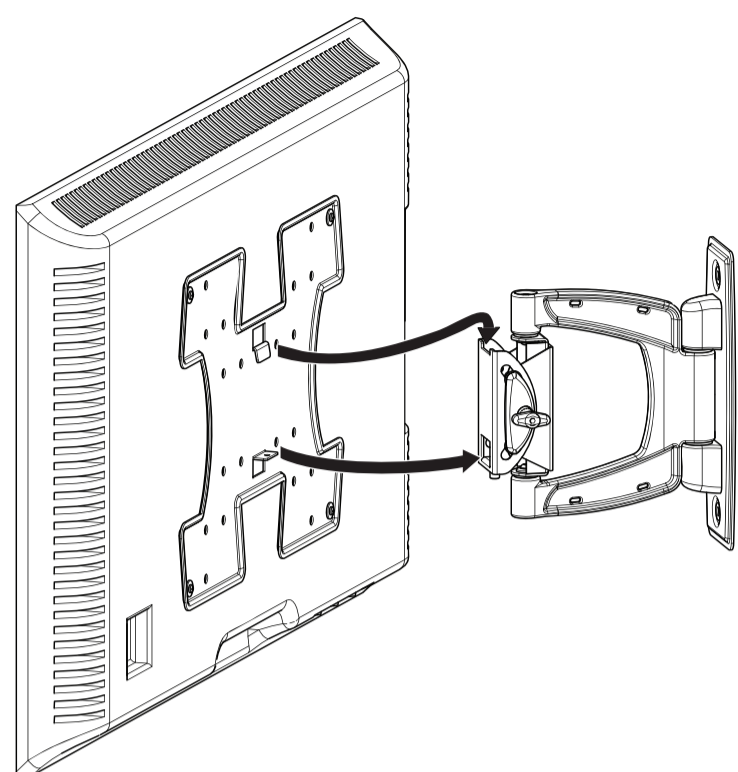

HEAVY! You will need assistance with this step.

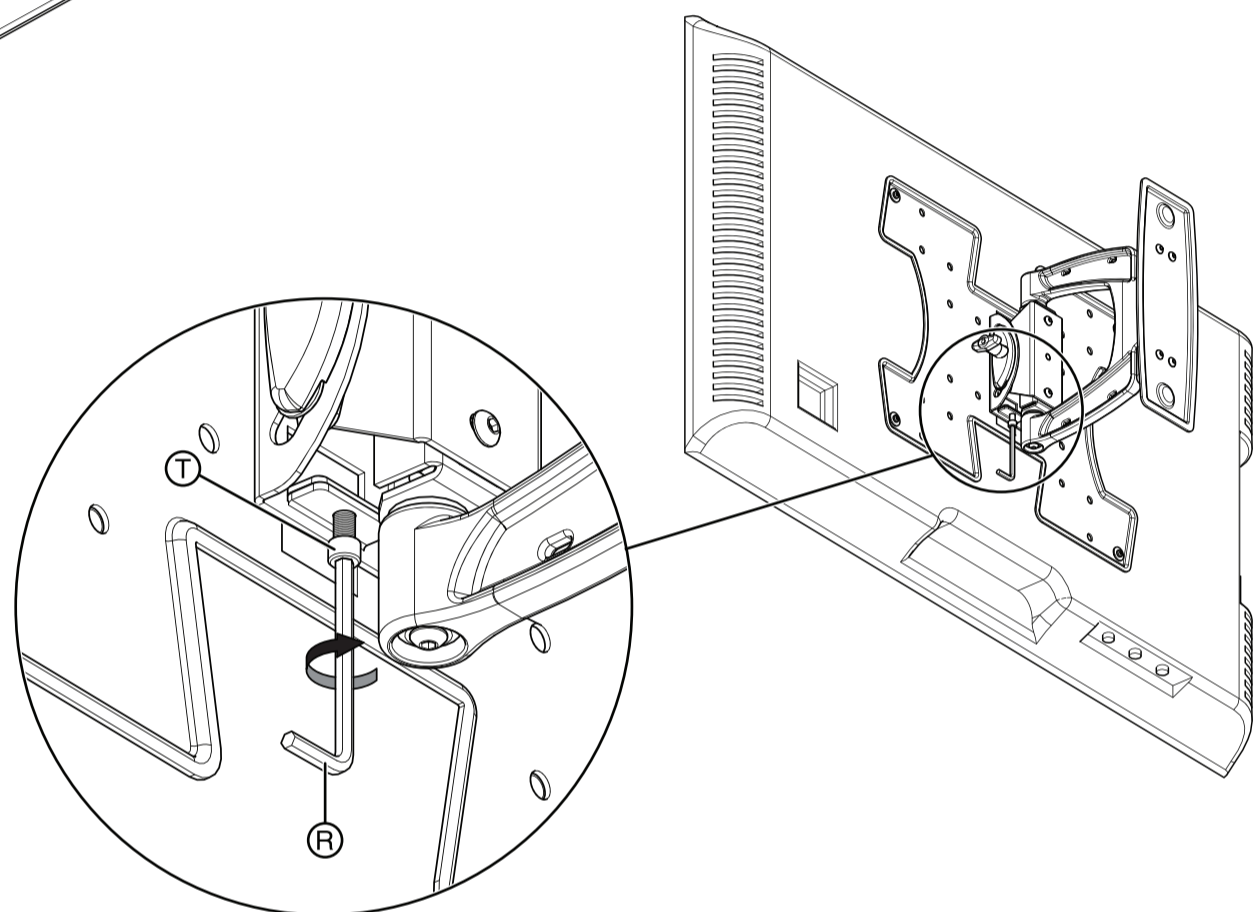

4 Adjust the viewing angle

When the television is mounted onto the arm assembly and secured, the assembly can be adjusted to make the TV level.

- 1 Loosen the two screws on the arm assembly using the 5/32 in. hex key (S).
- 2 Adjust the TV $\pm 6^\circ$ either clockwise or counter-clockwise.
- 3 Retighten the screws.

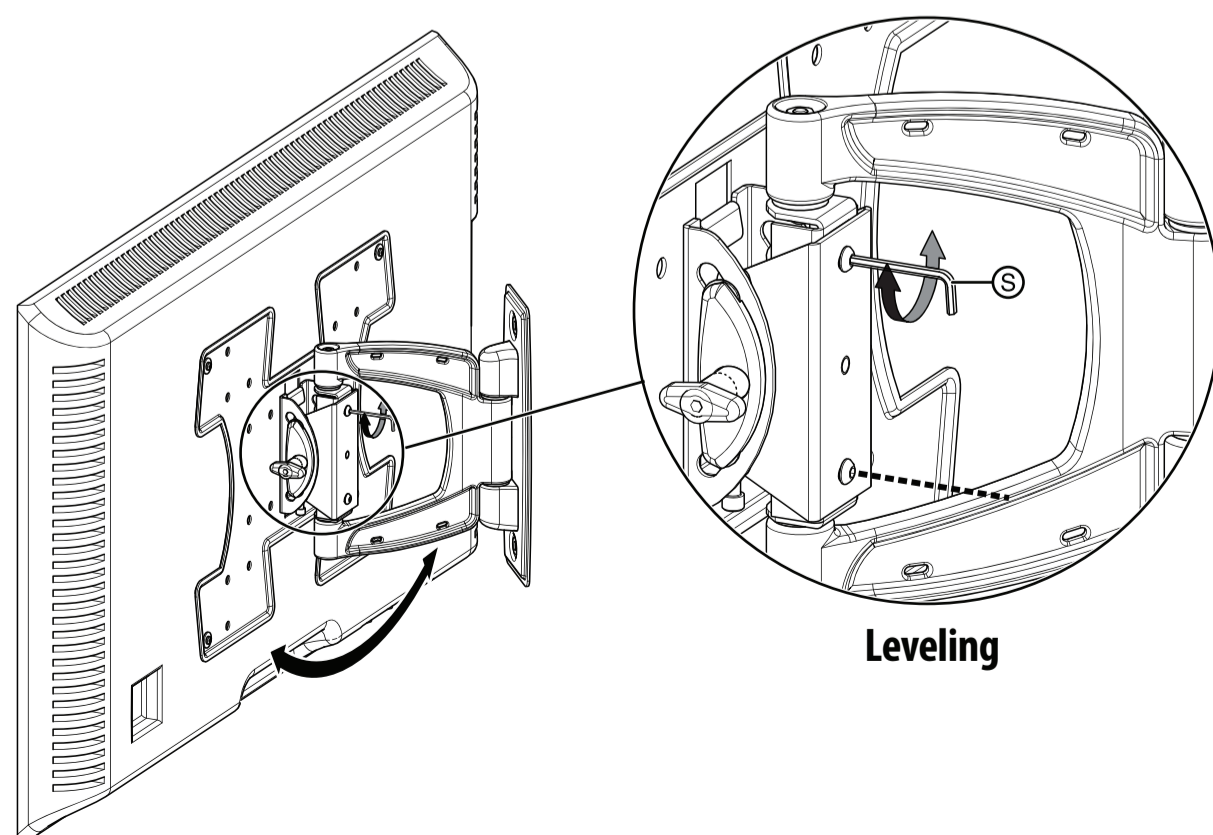

5 Adjust the swivel tension

Adjust the swivel tension using the 5/32 in. hex key (S).

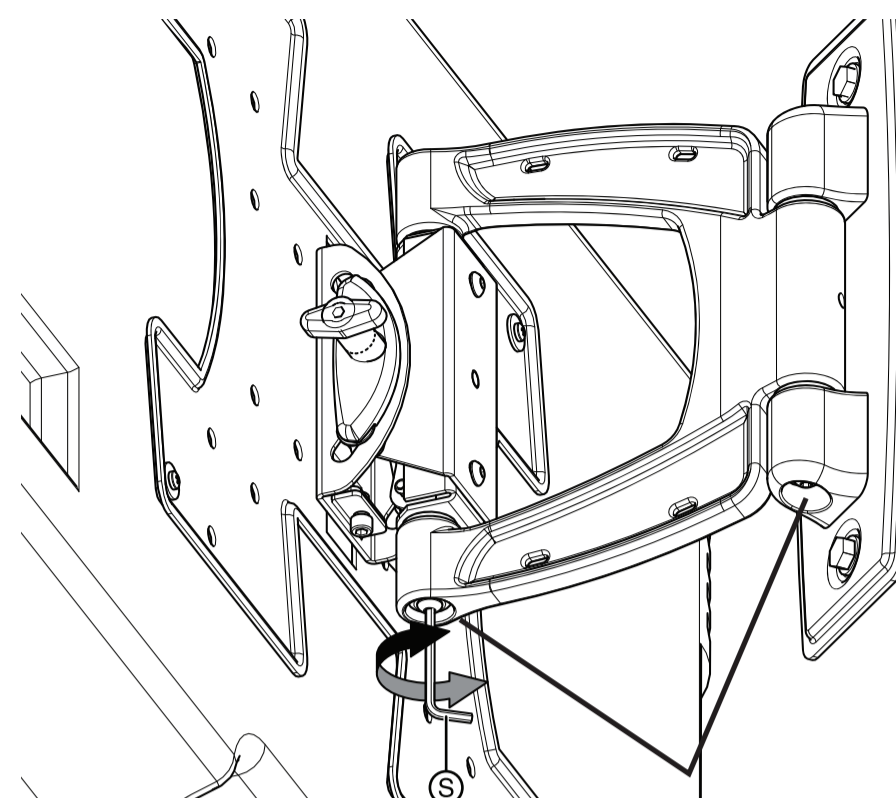

6 Manage the cables

Use cable ties (U) to bundle and secure the TV cables to the arm assembly.

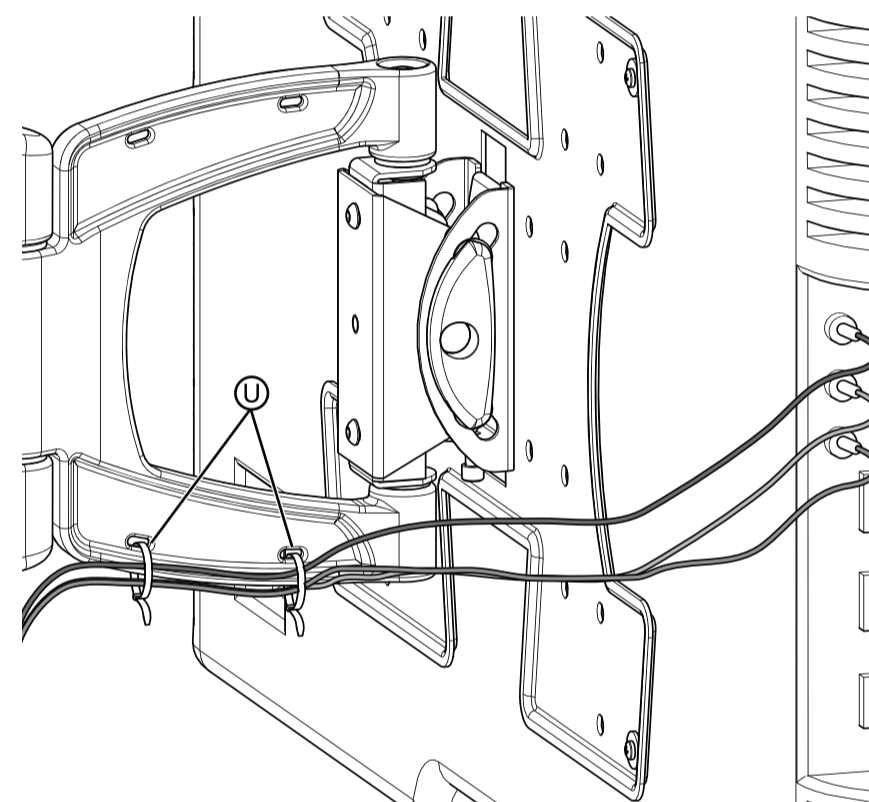

7 Adjust the tilt

Adjust the tilt of the TV forward or backward 10° using your fingers or the 3/16 in. hex key (R).

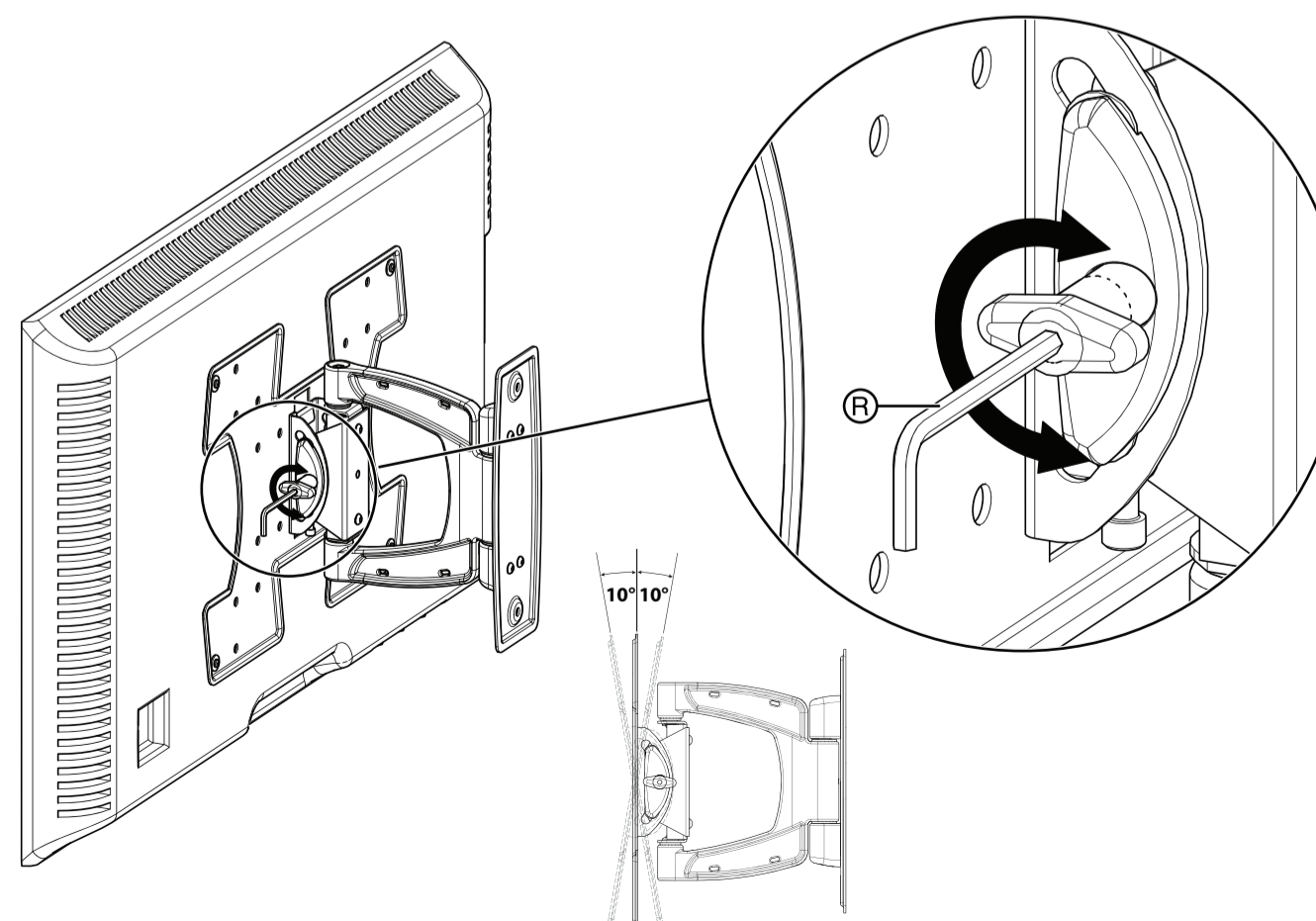

IMPORTANT SAFETY INSTRUCTIONS SAVE THESE INSTRUCTIONS

CAUTION: Do not use this product for any purpose not explicitly specified by Rocketfish. Improper installation may cause property damage or personal injury. If you do not understand these directions, or have doubts about the safety of the installation, contact Customer Service or call a qualified contractor. Rocketfish is not responsible for damage or injury caused by incorrect installation or use.

The weight of your TV must not exceed 60 lb (27.2 kg). The wall must be capable of supporting five times the weight of the TV and wall mount combined.

This product contains small items that could be a choking hazard if swallowed. Keep these items away from young children!

5-year limited warranty

Visit www.rocketfishproducts.com for details.

We're here for you

www.rocketfishproducts.com

For customer service, call:

800-620-2790 (U.S./Canada markets)