

punch 360.6
trans • ana

 **Rockford Fosgate**
car audio 

6-channel amplifier
operation & installation

punch

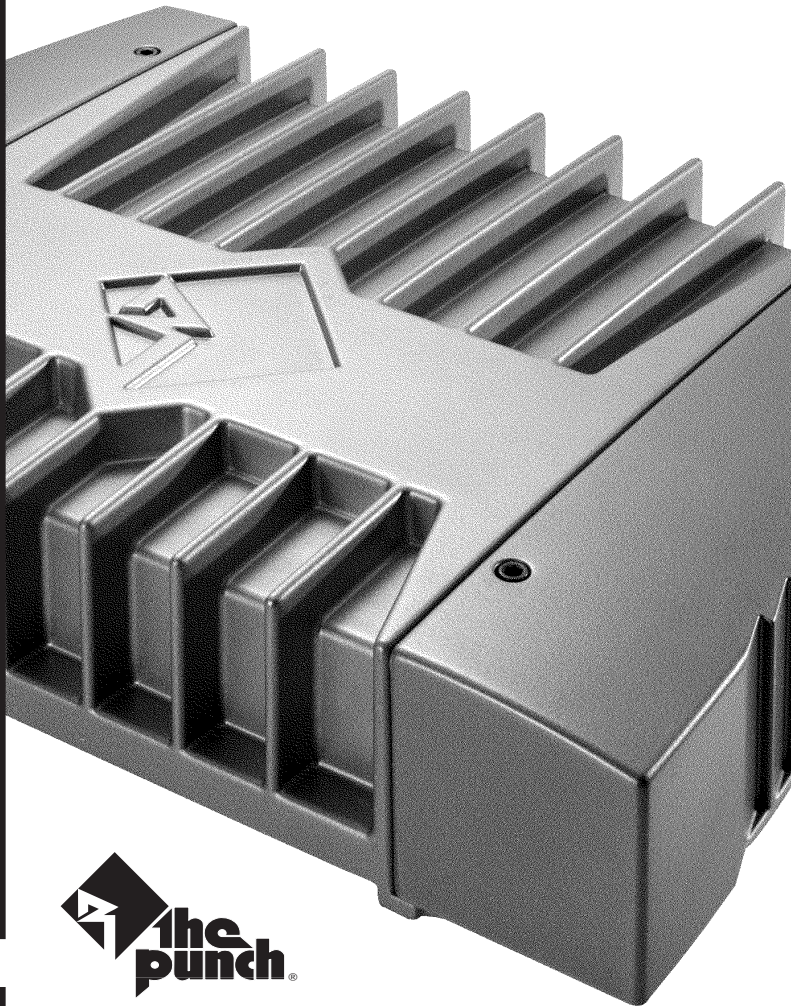

 **the
punch**

Dear Customer,

Congratulations on your purchase of the world's finest brand of car audio amplifiers. At Rockford Fosgate we are fanatics about musical reproduction at its best, and we are pleased you chose our product. Through years of engineering expertise, hand craftsmanship and critical testing procedures, we have created a wide range of products that reproduce music with all the clarity and richness you deserve.

For maximum performance we recommend you have your new Rockford Fosgate product installed by an Authorized Rockford Fosgate Dealer, as we provide specialized training through Rockford Technical Training Institute (RTTI). Please read your warranty and retain your receipt and original carton for possible future use.

Great product and competent installations are only a piece of the puzzle when it comes to your system. Make sure that your installer is using 100% authentic installation accessories from Connecting Punch in your installation. Connecting Punch has everything from RCA cables and speaker wire to Power line and battery connectors. Insist on it! After all, your new system deserves nothing but the best.

To add the finishing touch to your new Rockford Fosgate image order your Rockford wearables, which include everything from T-shirts and jackets to hats and sunglasses.

To get a free brochure on Rockford Fosgate products and Rockford accessories, in the U.S. call 602-967-3565 or FAX 602-967-8132. For all other countries, call +001-602-967-3565 or FAX +001-602-967-8132.

PRACTICE SAFE SOUND™

CONTINUOUS EXPOSURE TO SOUND PRESSURE LEVELS OVER 100dB MAY CAUSE PERMANENT HEARING LOSS. HIGH POWERED AUTOSOUND SYSTEMS MAY PRODUCE SOUND PRESSURE LEVELS WELL OVER 130dB. USE COMMON SENSE AND PRACTICE SAFE SOUND.

If, after reading your manual, you still have questions regarding this product, we recommend that you see your Rockford Fosgate dealer. If you need further assistance, you can call us direct at 1-800-795-2385. Be sure to have your serial number, model number and date of purchase available when you call.

The serial number can be found on the outside of the box. Please record it in the space provided below as your permanent record. This will serve as verification of your factory warranty and may become useful in recovering your amplifier if it is ever stolen.

Serial Number: _____

Model Number: _____

TABLE OF CONTENTS

Introduction	1
Punch Amplifier Accessory Pack	1
Technical Design Features	2
360.6 Design Features	5
Installation Considerations	7
Mounting Location	8
Battery and Charging	9
Wiring the System	9
Using the XCard	12
Customizing the XCard	12
Resistor Chart	13
XCard Configurations	14
Using the Phase Switch	16
Using the Signal Switching Network	17
360.6 Installation	25
System Diagrams	31
Troubleshooting	35
Dynamic Power Measurements	38
Specifications	40
Warranty Information	41
International Information	42

GETTING STARTED

Welcome to Rockford Fosgate! This manual is designed to provide information for the owner, salesperson and installer. For those of you who want quick information on how to install this product, please turn to the **Installation Section** of this manual or refer to the icons listed below. Other information can be located by using the Table of Contents. We, at Rockford Fosgate, have worked very hard to make sure all the information in this manual is current. But, as we are constantly finding new ways to improve our product, this information is subject to change without notice.



Sections marked
ADVANCED OPERATION
include in-depth
technical information

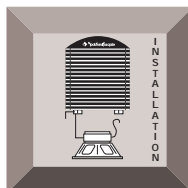

Sections marked
INSTALLATION
include "slam dunk"
wiring connections

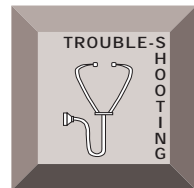

Sections marked
TROUBLESHOOTING
include recommendations
for curing
installation problems

INTRODUCTION

The Punch 360.6, is a 360 watt, 6 channel amplifier with integrated features for accommodating "single amplifier" system designs. Built into the amplifier are four internal XCards and a Signal Switching Network. These features simplify signal processing and enable custom signal distribution for each set of channels. Also integrated is a Phase Switch and Bass EQ circuit designed to improve system tuning. The engineering effort applied to the Punch 360.6 amplifier represents how an impressive 3-way system can be easily installed while keeping the components used to a minimum.

ACCESSORY PACK

Installation & Operation Manual

Punch Verification Certificate

- (4) Amplifier mounting screws (#8 x 3/4" Phillips)
- (16) Speaker & power connector screws (3/32" Allen)
- (4) End cap mounting screws (9/64" Allen)
- (1) Allen Wrench 9/64"
- (1) Allen Wrench 3/32"
- (1) AGU Fuseholder
- (1) AGU 50 Amp Fuse

TECHNICAL DESIGN FEATURES

◆ TRANS•ANA (TRANSconductance Active Nodal Amplifier)

The **TRANS•ANA** (TRANSconductance **A**ctive **N**odal **A**mplifier) is a circuit that allows the audio signal to pass through the amplifier at **low voltage**. The signal is directly level-shifted to the fixed high voltage rails via a pair of driver transistors. Signal linearity is assured by an **active node** formed by the drive transistors at ultrasonic frequencies. This allows amplifier performance similar to **trans•nova** which is highly stable and linear while utilizing the advantages of a non-floating power supply.

THE RESULT: An extended frequency bandwidth accurately supplied to the output stages of the amplifier.

◆ TOPAZ (Tracking Operation Pre-Amplifier Zone)

The **TOPAZ** (Tracking **O**peration **P**re-**A**mplifier **Z**one) circuitry solves ground loop noise problems common to automotive amplifier design. This innovative new development allows vastly improved isolation of the input signal grounds from the power supply ground of the amplifier. This is accomplished by allowing the source unit to control the potential “environment” of the entire input structure or “zone” of the amplifier. This process improves the noise rejection of the amplifier by 30-40dB – an astounding 30-100 times better than amplifiers without TOPAZ.

THE RESULT: Elimination of troublesome ground loop noise between source and amplifier.

◆ Bass EQ

The Bass EQ helps correct for acoustical deficiencies in the listening environment. A unique potentiometer that controls bass compensates for the lack of low frequencies present in most car environments. Unlike a conventional tone control, the Bass EQ corrects the specific problem of poor low bass response.

THE RESULT: Provides better low bass response.

◆ DSM (Discrete Surface Mount) Technology

The **DSM** (Discrete Surface Mount) manufacturing process combines the advantages of both discrete components and integrated circuitry. Rockford Fosgate is the only American amplifier manufacturer to have invested millions into this process. DSM components differ from conventional discrete components in different ways. They are more compact, more rugged, and they efficiently dissipate generated heat. Using them wherever appropriate allows the advantages associated with discrete circuitry to be retained while also providing room for both highly advanced processing features and generous PC board copper paths where needed. Their short lead-out structures allow maximum audio performance and highest signal-to-noise ratios to be obtained in amplifiers of desirable package size without resorting to “amplifier-on-a-chip” shortcuts. These advantages are shown below in Figure 1.

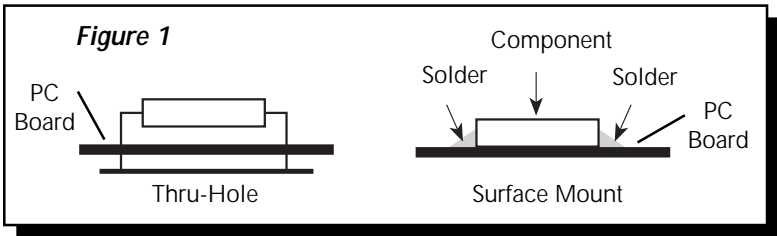

THE RESULT: Fewer connections, improved reliability, shorter signal paths, superior signal-to-noise ratio and awesome sonic performance.

◆ XCard (Internal Crossover)

The Punch amplifiers utilize internal active crossovers. These crossovers have many performance advantages such as using discrete components for exact frequency adjustments which are far superior to potentiometers. Additionally, the **XCard** can be configured for high-pass, low-pass and full range operation. With slight modifications, many crossover frequencies and slope configurations can be achieved.

THE RESULT: Increased system design flexibility with a precise electronic crossover without the limitations of conventional potentiometer designs.

◆ MOSFET Devices

Rockford Fosgate is one of the few manufacturers in the sound community to utilize MOSFET devices in both the **power supply** and the **output stages**. **MOSFET** (Metal **O**xide **S**emiconductor **F**ield **E**ffect **T**ransistor) devices offer several important inherent advantages over the 30 year old technology of bi-polar design. These advantages include: thermal stability, switching speed, ultra low output impedance and wider bandwidth linearity. In addition, MOSFETs operate very similarly to vacuum tubes in which they are more linear than bi-polar transistors. However, MOSFETs can deliver the midrange clarity without the limitations of transient response and high frequency phase shifting normally associated with tube operation.

THE RESULT: Operational characteristics similar to vacuum tubes without the performance limitations of tube design.

◆ NOMAD (NON-Multiplying Advanced Decision)

The Punch amplifiers use an **analog computer process** to maximize safe output power under all operating conditions. The innovative **NOMAD** (NON-Multiplying **A**dvanced **D**ecision) system is the most sophisticated version of this technique ever used, bringing previously unavailable levels of accuracy, stability, temperature immunity and reliability to this critical process. NOMAD makes advanced decisions based on device voltages to precisely control the awesome levels of current available in the output MOSFETs to safe values – but only when absolutely needed.

THE RESULT: Extremely fast protection system that always protects the amplifier and never degrades the sound.

◆ Signal Switching Network

The Signal Switching Network allows the RCA input signals to be distributed to the amplifier channels in multiple configurations. Among the many possible configurations, a setting called **E-Z bridge** uses a single RCA (L mono) and gain (L) control to feed a pair of channels, thus simplifying the bridging process.

THE RESULT: Allows input signals to be distributed to amplifier channels in many different configurations.

360.6 DESIGN FEATURES

1. **Cast Aluminum Heatsink** – The cast aluminum heatsink of the Punch amplifier dissipates heat generated by the amplifier's circuitry. The inherent advantage of casting provides a 30% improvement of cooling over conventional extrusion heatsink designs.
2. **End Caps** – The unique end caps conceal the wiring and input cables, giving the amplifier a clean "stealth" look.

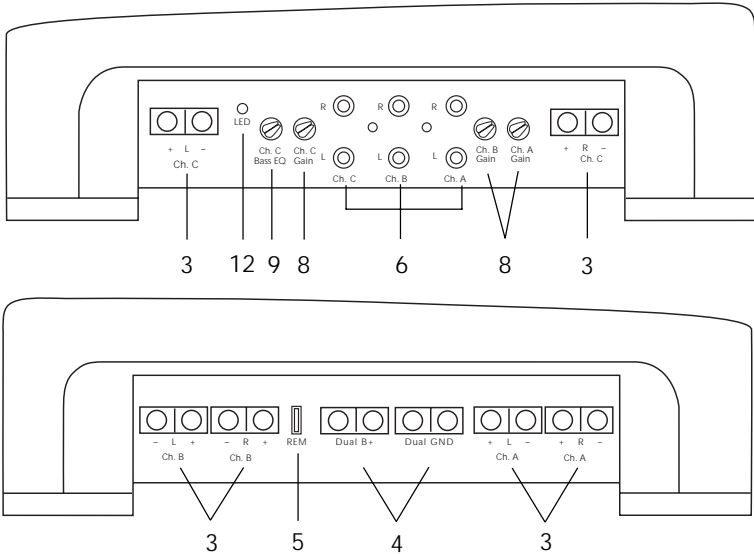

3. **Speaker Terminals** – The heavy duty, gold-plated terminal block connectors (+ and -) will accept wire sizes from 8 AWG to 18 AWG. These gold-plated connectors are immune to corrosion that can cause signal deterioration.
4. **Power Terminals** – The power and ground connectors on the Punch amplifier are gold-plated and will accommodate up to 8 AWG wire maximizing the input current capability of the amplifier.
5. **REM Terminal** – This gold-plated spade terminal is used for the auto power/remote turn on of the Punch amplifier.
6. **RCA Input Jacks** – The industry standard RCA jacks provide easy connections for signal level input. They are gold-plated to resist the signal degradation caused by corrosion.
7. **Signal Input Switches** – These switches allow the input signals to be distributed to the outputs in many different configurations.

8. **Input Sensitivity Controls** – The input level controls are preset to match the output of most source units. They can be adjusted to match output levels from a variety of source units.
9. **Bass EQ Control** – The Bass EQ allows a narrow band adjustment of up to +18dB centered at 45Hz. The bass boost can be bypassed by turning the control to its minimum or counterclockwise position. **The Bass EQ is dedicated for "Channel C" only.**
10. **Internal Crossovers** – These built-in crossover cards are configurable for a multitude of operating frequencies. The orientation of the card in its socket determines the function of high-pass, low-pass, or full range operation.
11. **Channel C Phase Switch** – This switch enables you to easily invert the phase of "Channel C" (0°/180°) without having to disconnect the speaker wires.
12. **LED Power Indicator** – The LED illuminates when the unit is turned on.

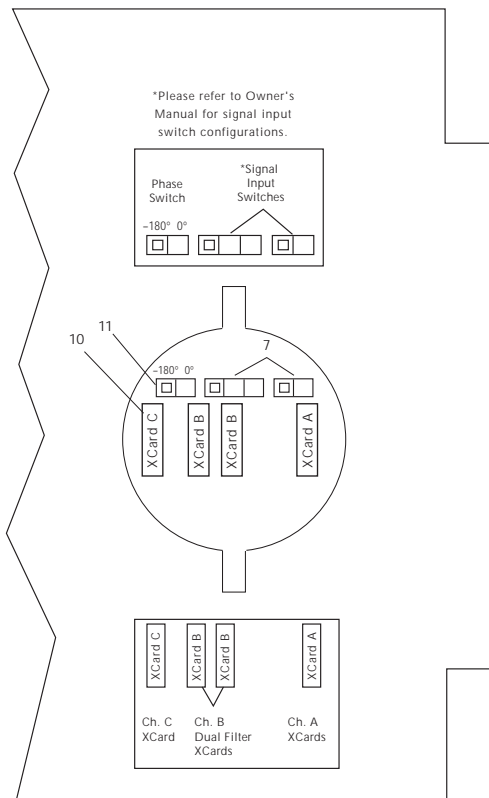

INSTALLATION CONSIDERATIONS

The following is a list of tools you will need for installing the Punch amplifier:

Allen wrenches 9/64" & 3/32" (included)	Voltmeter
Wire strippers	Battery post wrench
Electric hand drill w/assorted bits	Wire cutters
Wire crimpers	Assorted connectors

This section focuses on some of the vehicle considerations for installing your new Punch amplifier. Checking your battery and present sound system, as well as pre-planning your system layout and best wiring routes will save installation time. When deciding how to lay out your new system, be sure that each component will be easily accessible for making adjustments.

Before beginning any installation, be sure to follow these simple rules:

1. Be sure to carefully read and understand the instructions before attempting to install the amplifier.
2. **For safety**, disconnect the negative lead from the battery prior to beginning the installation.
3. For easier assembly, we suggest you run all wires prior to mounting your amplifier in place.
4. Route all of the RCA cables close together and away from any high current wires.
5. Use high quality connectors for a reliable installation and to minimize signal or power loss.
6. **Think before you drill!** Be careful not to cut or drill into gas tanks, fuel lines, brake or hydraulic lines, vacuum lines or electrical wiring when working on any vehicle.
7. Never run wires underneath the vehicle. Running the wires inside the vehicle provides the best protection.
8. Avoid running wires over or through sharp edges. Use rubber or plastic grommets to protect any wires routed through metal, especially the firewall.
9. **ALWAYS** protect the battery and electrical system from damage with proper fusing. Install a fuseholder and appropriate fuse on the +12V power wire within 18" (45.7 cm) of the battery terminal.
10. When grounding to the chassis of the vehicle, scrape all paint from the metal to ensure a good, clean ground connection. Grounding connections should be as short as possible and always be connected to metal that is welded to the main body, or chassis, of the vehicle.

MOUNTING LOCATION

The mounting location and position of your amplifier will have a great effect on its ability to dissipate the heat generated during normal operation. The design of our cast aluminum heatsink serves to easily dissipate the heat generated over a wide range of operating conditions. However, to maximize the performance of your amplifier, care should be taken to ensure adequate ventilation.

Trunk Mounting

Mounting the amplifier vertically on a surface with the fin grooves running up and down will provide the best cooling of the amplifier.

Mounting the amplifier on the floor of the trunk will work but provides less cooling capability than vertical mounting.

Mounting the amplifier upside down to the rear deck of the trunk will not provide proper cooling and will severely affect the performance of the amplifier and is strongly **not** recommended.

Passenger Compartment Mounting

Mounting the amplifier in the passenger compartment will work as long as you provide a sufficient amount of air for the amplifier to cool itself. If you are going to mount the amplifier under the seat of the vehicle, you must have at least 1" (2.54cm) of air gap around the amplifier's heatsink.

Mounting the amplifier with less than 1" (2.54cm) of air gap around the amplifier's heatsink in the passenger compartment will not provide proper cooling and will severely affect the performance of the amplifier and is strongly **not** recommended.

Engine Compartment Mounting

Rockford Fosgate amplifiers should **never** be mounted in the engine compartment. Not only will this void your warranty but could create an embarrassing situation caused by the ridicule from your friends.

BATTERY AND CHARGING

Amplifiers will put an increased load on the vehicle's battery and charging system. We recommend checking your alternator and battery condition to ensure that the electrical system has enough capacity to handle the increased load of your stereo system. Stock electrical systems which are in good condition should be able to handle the extra load of any Rockford amplifier without problems, although battery and alternator life can be reduced slightly. To maximize the performance of your Rockford Fosgate amplifier, we suggest the use of a heavy duty battery and an energy storage capacitor.

WIRING THE SYSTEM

CAUTION: *Avoid running power wires near the low level input cables, antenna, power leads, sensitive equipment or harnesses. The power wires carry substantial current and could induce noise into the audio system.*

- **For safety**, disconnect the negative lead from the battery prior to beginning the installation.
1. Configure the internal XCard crossover and Signal Switching Network prior to installation. Refer to pages 12 & 13 for further information.
 2. Plan the wire routing. Take care when running signal level RCA cables to keep them close together but isolated from the amplifier's power cables and any high power auto accessories, especially electric motors. This is done to prevent coupling the noise from radiated electrical fields into the audio signal. When feeding the wires through the firewall or any metal barrier, protect them with plastic or rubber grommets to prevent short circuits. Leave the wires long at this point to adjust for a precise fit at a later time.
 3. Prepare the **Power** cable for attachment to the amplifier by stripping 5/8" of insulation from the end of the wire. To prevent the wire from fraying, strip the insulation at a 45° angle. Insert the bared wire into the B+ terminal with the long side of the insulation on the top. Bend the cable down at a 90° angle. Tighten the set screw to secure the cable in place.

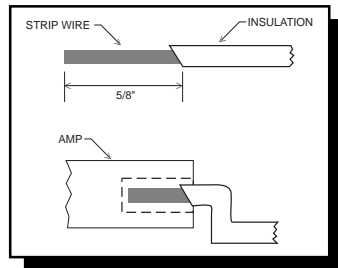

Mount the fuseholder within 18" of the battery using two (2) #8 screws. Disassemble the fuseholder. You should have 2 black plastic end caps, 2 gold-plated fuse clips, a plastic spacer and the fuseholder body. Trim the amplifier power cable to reach the fuseholder and strip the wire 3/8". Slide one of the end caps over the wire (narrow end first) and insert the wire into one of the fuse clips. Tighten the set screw. Screw the black end cap to the fuseholder body to secure the cable. Use the section of cable that was trimmed earlier and connect it to the other end of the fuseholder. Install the plastic spacer in the fuseholder and attach the cable to the fuseholder body.

NOTE: The B+ cable MUST be fused 18" or less from the vehicle's battery. Install the fuseholder under the hood and prepare the cable ends as stated above. Connections should be water tight.

4. Strip 3/8" from the battery end of the power cable and crimp a large ring terminal to the cable. Use the ring terminal to connect to the battery positive terminal. **Do not install the fuse at this time.**
5. Prepare a length of cable to be used for the GND connection. Strip 5/8" of insulation from the end of the cable as described previously and connect to the appropriate terminal of the amplifier. Prepare the chassis ground by scraping any paint from the metal surface and thoroughly clean the area of all dirt and grease. Strip the other end of the wire and attach a ring connector. Fasten the cable to the chassis using a non-anodized screw and a star washer.
6. Prepare the REM turn-on wire for connection to the amplifier by stripping 1/4" of insulation from the wire end and crimping an insulated spade connector in place. Slide the connector over the REM terminal on the amplifier. Connect the other end of the REM wire to a switched 12 volt positive source. The switched signal is usually taken from the source unit's auto antenna or the accessory lead. If the source unit does not have these outputs available, the recommended solution is to wire a mechanical switch in line with a 12 volt source to activate the amplifier.
7. Securely mount the amplifier (with supplied screws) to the vehicle or amp rack. Be careful not to mount the amplifier on cardboard or plastic panels. Doing so may enable the screws to pull out from the panel due to road vibration or sudden vehicle stops.

8. Connect the source signal to the amplifier by plugging the RCA cables into the input jacks at the amplifier.
9. Connect the speakers. Strip the speaker wires 5/8". Insert the bared wire into the speaker terminal and tighten the set screw to secure into place. Be sure to maintain proper speaker polarity. ***DONOT chassis ground any of the speaker leads as unstable operation may result.***
10. Perform a final check of the completed system wiring to ensure that all connections are accurate. Check all power and ground connections for frayed wires and loose connections which could cause problems.
11. After the final inspection is complete, install the power fuse and enjoy listening. During the initial listening period, you may need to "fine tune" any phasing and level settings within your particular vehicle. To aid in this procedure, play a track with high musical content and cruise around your neighborhood. After fully evaluating the transient response of your system and making any final adjustments, all your neighbors within a 1 mile radius will assume that you have just successfully completed another upgrade to your audio system for which they will probably spill thumbtacks on your driveway.

USING THE XCARD

The crossover functions are controlled through the use of an XCard and can be set for high-pass, low-pass or full range operation. The XCard installed in your amplifier is set for Full Range. Each crossover card has two faces: one face operates **Full Range**, the other has arrows to indicate the edge for selecting **HP** (high-pass) or **LP** (low-pass) operation. Orient the card with the desired operating edge, indicated by the arrow, toward the socket terminals inside the amplifier. Firmly, but carefully, plug the card into the socket.

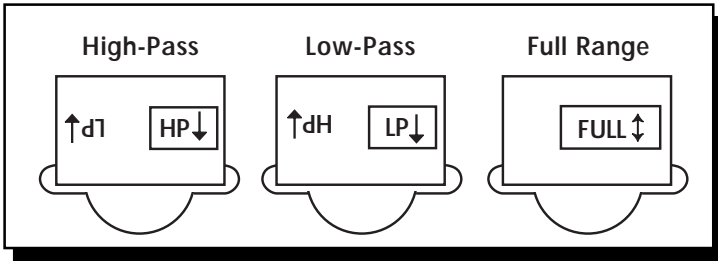

CUSTOMIZING THE XCARD

The crossover point can be altered by changing all 4 resistor values. Use the following formula to select the appropriate resistor value to be placed on the XCard.

$$\frac{3386}{f_o} = R \text{ (in } k\Omega \text{) for } .047\mu\text{f cap}$$

$$\frac{7234}{f_o} = R \text{ (in } k\Omega \text{) for } .022\mu\text{f cap}$$

The actual formula is:

$$R = \frac{1}{2\pi f_o c}$$

Where: $R = \Omega$

f_o = desired crossover frequency

c = capacitor in farads

ex: $.047 \times 10^{-6}$ for .047mf cap

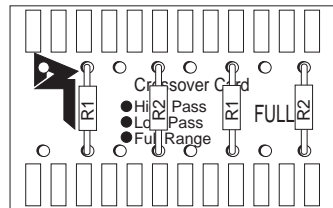

RESISTOR CHART

Our tests have shown that using 0.047 μ F capacitors for frequencies below 100Hz, and 0.022 μ F capacitors for frequencies above 100Hz, result in more linear crossover control. Refer to the Specifications page to determine the capacitor value of each supplied XCard.

Butterworth Alignment $Q = .707$
 1% resistors used with 0.047 μ F caps

Frequency	R1	R2
20Hz	169k Ω	169k Ω
25Hz	133k Ω	133k Ω
30Hz	110k Ω	110k Ω
35Hz	95.3k Ω	95.3k Ω
40Hz	84.5k Ω	84.5k Ω
45Hz	75k Ω	75k Ω
50Hz	68.1k Ω	68.1k Ω
55Hz	61.9k Ω	61.9k Ω
60Hz	56.2k Ω	56.2k Ω
65Hz	52.3k Ω	52.3k Ω
70Hz	48.7k Ω	48.7k Ω
75Hz	45.3k Ω	45.3k Ω
80Hz	42.2k Ω	42.2k Ω
85Hz	40.2k Ω	40.2k Ω
90Hz	37.4k Ω	37.4k Ω
200Hz	16.9k Ω	16.9k Ω
300Hz	11.3k Ω	11.3k Ω
400Hz	8.45k Ω	8.45k Ω
500Hz	6.65k Ω	6.65k Ω
600Hz	5.62k Ω	5.62k Ω
700Hz	4.75k Ω	4.75k Ω
800Hz	4.22k Ω	4.22k Ω
900Hz	3.74k Ω	3.74k Ω
1kHz	3.40k Ω	3.40k Ω
1.2kHz	2.80k Ω	2.80k Ω
2kHz	1.69k Ω	1.69k Ω
3kHz	1.10k Ω	1.10k Ω
4kHz	845 Ω	845 Ω
5kHz	665 Ω	665 Ω
6kHz	562 Ω	562 Ω
7kHz	487 Ω	487 Ω
8kHz	422 Ω	422 Ω

Butterworth Alignment $Q = .707$
 1% resistors used with 0.022 μ F caps

Frequency	R1	R2
20Hz	357k Ω	357k Ω
25Hz	287k Ω	287k Ω
30Hz	237k Ω	237k Ω
35Hz	205k Ω	205k Ω
40Hz	178k Ω	178k Ω
45Hz	162k Ω	162k Ω
50Hz	143k Ω	143k Ω
55Hz	130k Ω	130k Ω
60Hz	121k Ω	121k Ω
65Hz	110k Ω	110k Ω
70Hz	102k Ω	102k Ω
75Hz	95.3k Ω	95.3k Ω
80Hz	90.9k Ω	90.9k Ω
85Hz	84.5k Ω	84.5k Ω
90Hz	80.6k Ω	80.6k Ω
200Hz	35.7k Ω	35.7k Ω
300Hz	23.7k Ω	23.7k Ω
400Hz	17.8k Ω	17.8k Ω
500Hz	14.3k Ω	14.3k Ω
600Hz	12.1k Ω	12.1k Ω
700Hz	10.2k Ω	10.2k Ω
800Hz	9.9k Ω	9.9k Ω
900Hz	8.6k Ω	8.6k Ω
1.0kHz	7.15k Ω	7.15k Ω
1.2kHz	6.04k Ω	6.04k Ω
2.0kHz	3.57k Ω	3.57k Ω
3.0kHz	2.37k Ω	2.37k Ω
4.0kHz	1.76k Ω	1.76k Ω
5.0kHz	1.43k Ω	1.43k Ω
6.0kHz	1.21k Ω	1.21k Ω
7.0kHz	1.02k Ω	1.02k Ω
8.0kHz	909 Ω	909 Ω

XCARD CONFIGURATIONS

Configure a 12dB/octave filter for Channel A

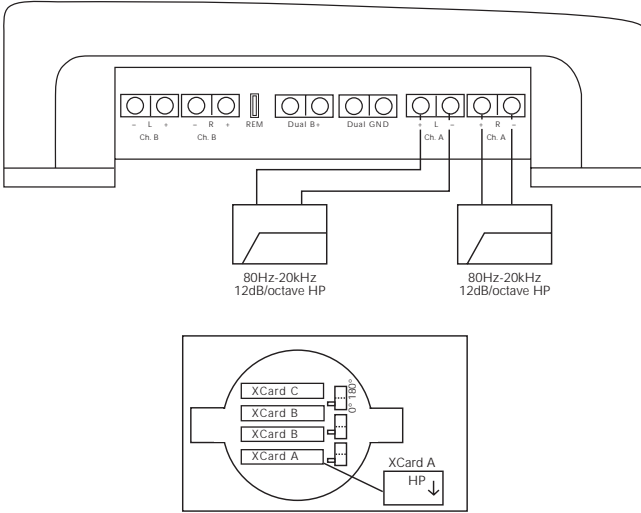

- XCard A set to High-Pass or Low-Pass

Configure a 12dB/octave filter for Channel B

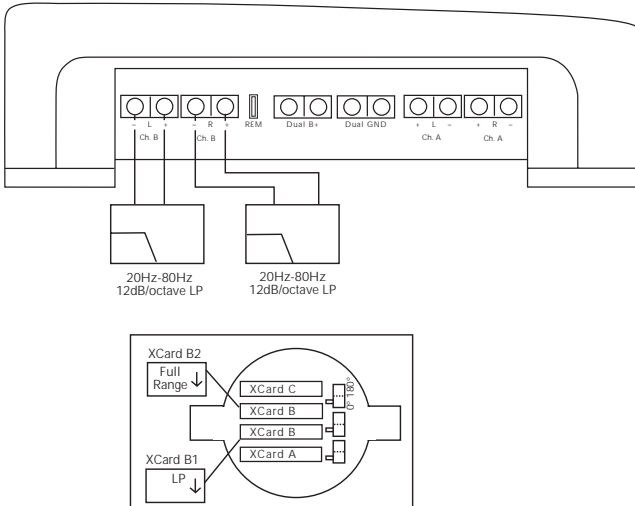

- XCard B1 set to High-Pass or Low-Pass
- XCard B2 set to Full Range

Configure a 24dB/octave filter for Channel B

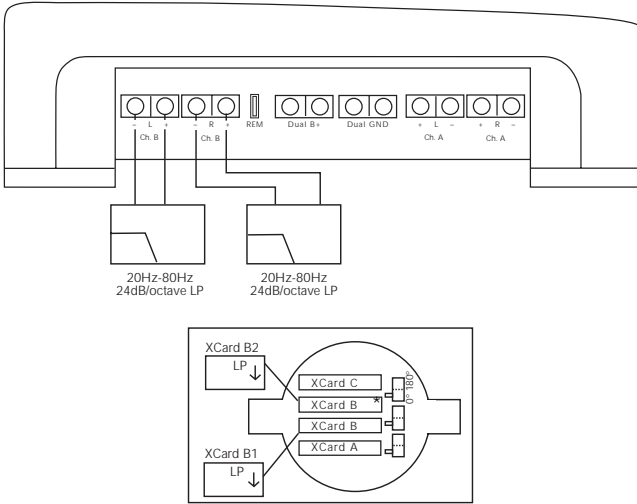

- XCard B1 & B2 set identically to High-Pass or Low-Pass

***Note: Both XCards must be customized to the same frequency for proper 24dB/octave operation. Refer to "Using the XCard" on page 12 for altering the cutoff frequency.**

Configure a 12dB/octave Bandpass filter for Channel B

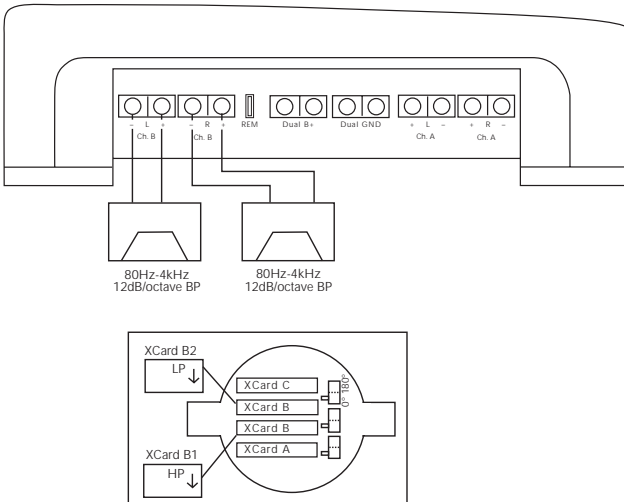

- XCard B1 inserted as High-Pass
- XCard B2 inserted as Low-Pass

Configure a 12dB/octave Low-Pass filter for Channel C

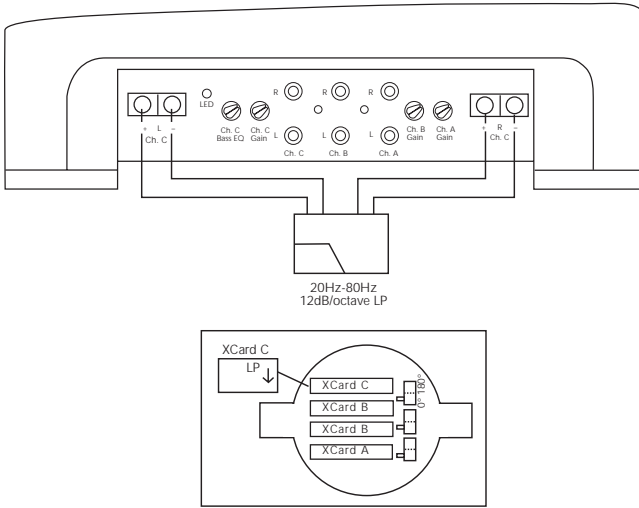

- XCard C set to High-Pass or Low-Pass

USING THE PHASE SWITCH

Vehicle interiors can cause acoustical irregularities with the system's bass response. The Punch amplifier has a 0° – 180° phase switch that allows both Channel C outputs to be inverted simultaneously. Since woofers will typically be connected to Channel C, the system's bass response can be improved by experimenting with the phase switch.

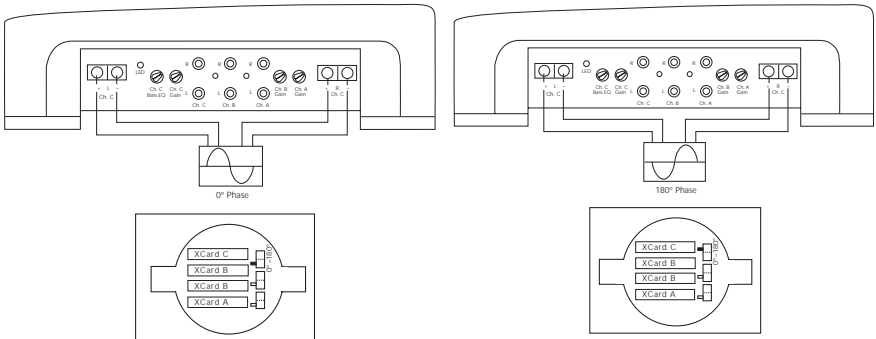

- Phase Switch set to 0°

- Phase Switch set to -180°

USING THE SIGNAL SWITCHING NETWORK

The Signal Switching Network allows the RCA input signals to be distributed to the outputs in many different configurations. **The orientation of both switches configure the distribution pattern.** The switches can be oriented in the following configurations:

Configuration #1

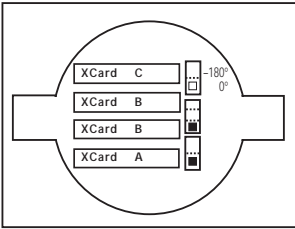

Ch. **A** inputs => Ch. **A** outputs
 Ch. **B** inputs => Ch. **B** outputs
 Ch. **A & B** inputs *summed* => Ch. **C** outputs

Factory Default Setting

Configuration #2

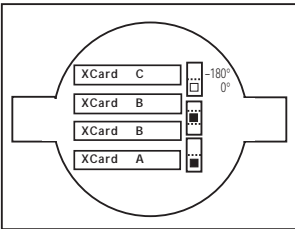

Ch. **A** inputs => Ch. **A** outputs
 Ch. **B** inputs => Ch. **B** outputs
 Ch. **C** inputs => Ch. **C** outputs

Configuration #3 (E-Z bridge Ch. C)

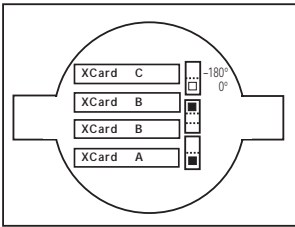

Ch. **A** inputs => Ch. **A** outputs
 Ch. **B** inputs => Ch. **B** outputs
 Ch. **C (L mono)** input => Ch. **C** outputs

Configuration #4

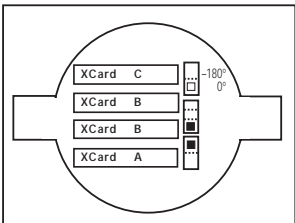

Ch. **A** inputs => Ch. **A, B, & C** outputs

Configuration #5

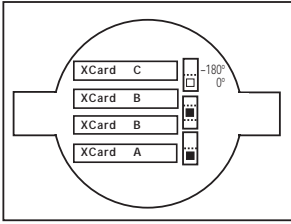

Ch. **A** inputs => Ch. **A & B** outputs
Ch. **C** inputs => Ch. **C** outputs

Configuration #6 (E-Z bridge Ch. C)

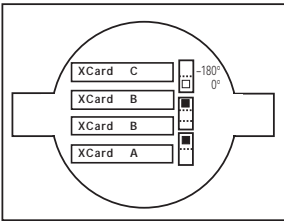

Ch. **A** inputs => Ch. **A & B** outputs
Ch. **C (L mono)** input => Ch. **C** outputs

Configuration #1

Ch. A inputs => Ch. A outputs
 Ch. B inputs => Ch. B outputs
 Ch. A & B inputs *summed* => Ch. C outputs

**Factory Default
 Setting**

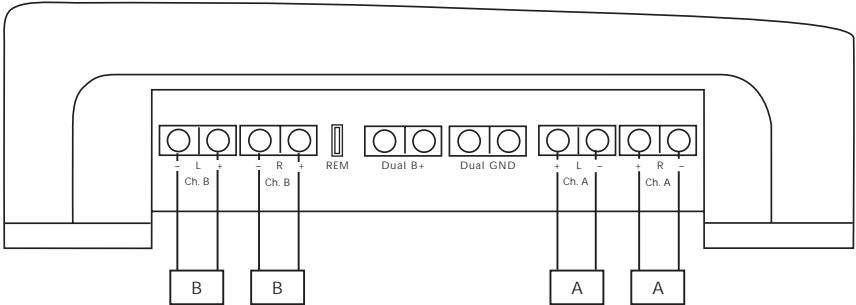
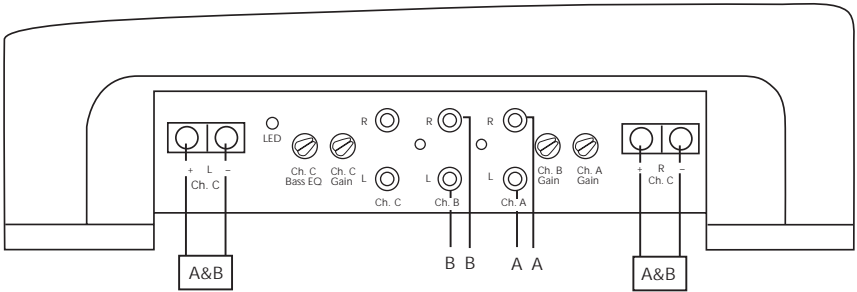
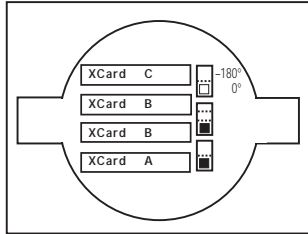

Configuration #2

Ch. A inputs => Ch. A outputs
 Ch. B inputs => Ch. B outputs
 Ch. C inputs => Ch. C outputs

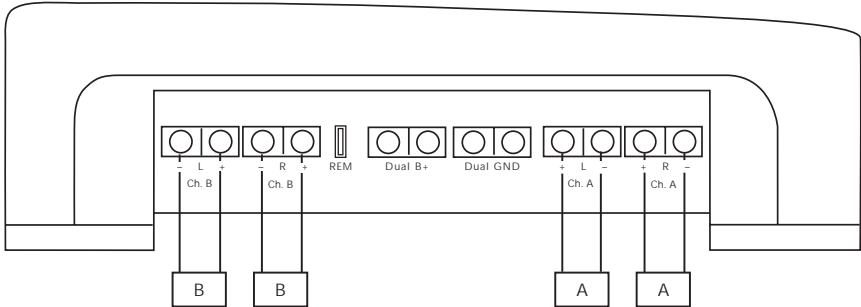
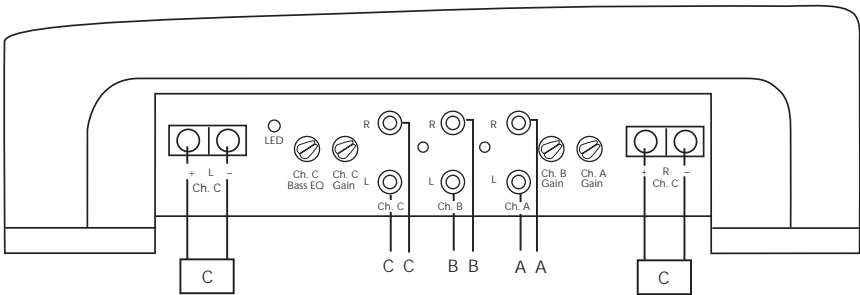
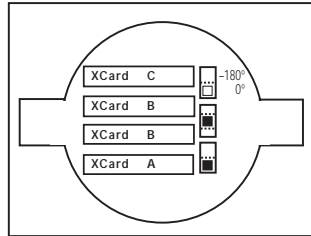

Configuration #3
(E-Z bridge Ch. C)

Ch. A inputs => Ch. A outputs
 Ch. B inputs => Ch. B outputs
 Ch. C (L mono) input => Ch. C outputs

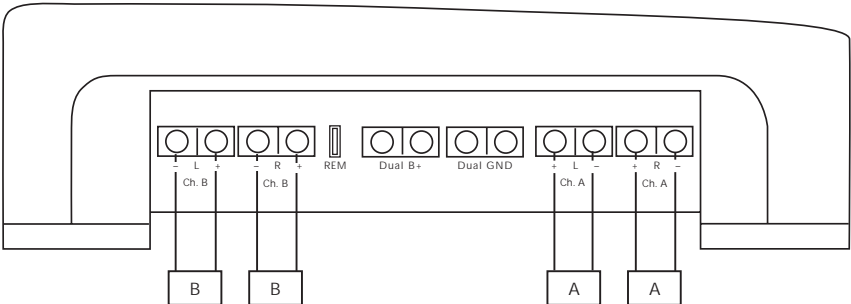
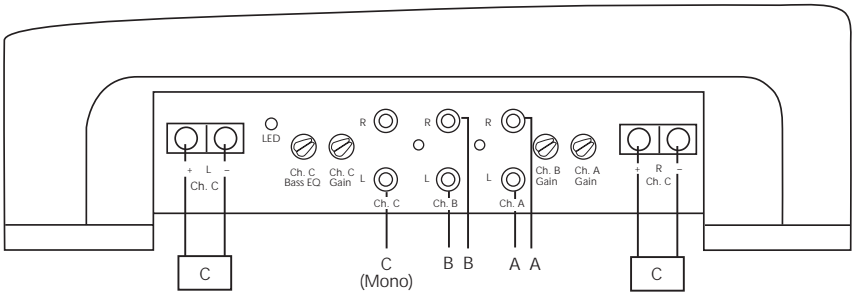
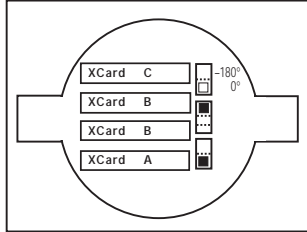

Configuration #4

Ch. A inputs => Ch. A, B, & C outputs

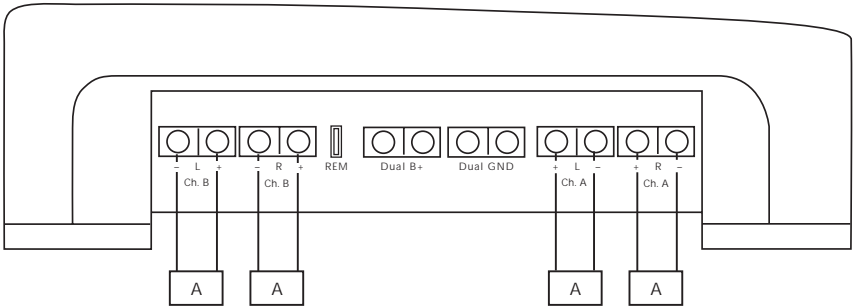
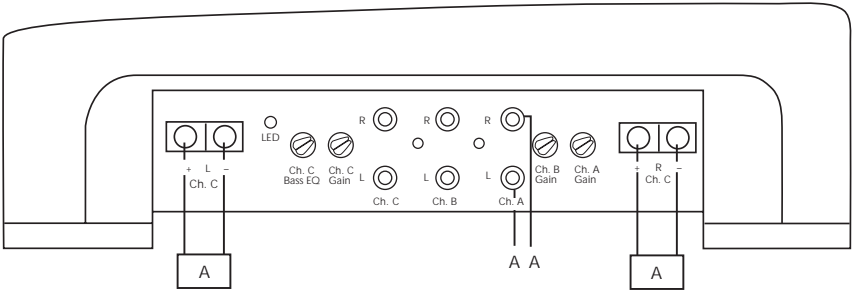
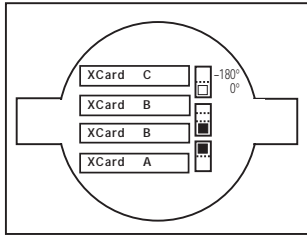

Configuration #5

Ch. A inputs => Ch. A & B outputs
 Ch. C inputs => Ch. C outputs

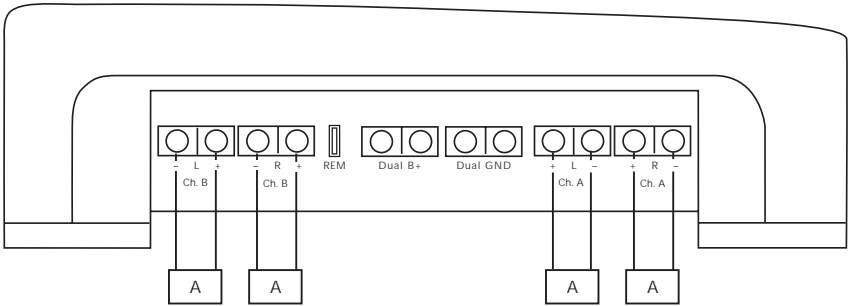
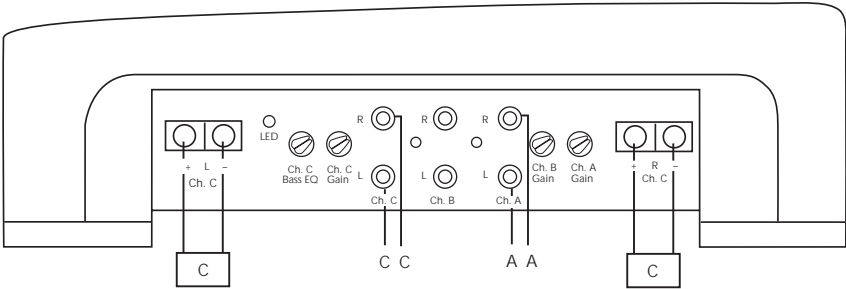
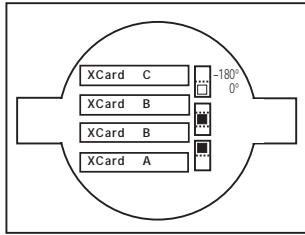

Configuration #6
(E-Z bridge Ch. C)

Ch. A inputs => Ch. A & B outputs
 Ch. C (L mono) input => Ch. C outputs

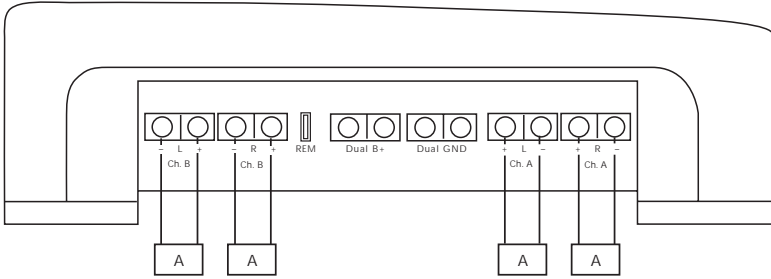
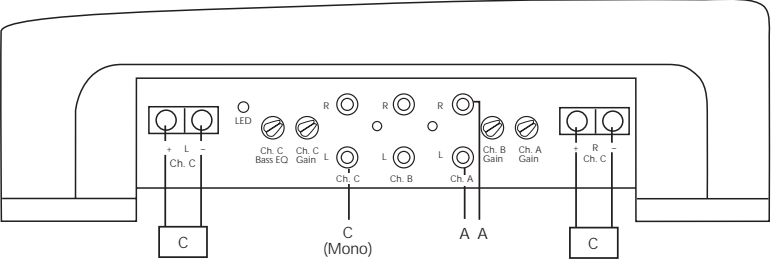
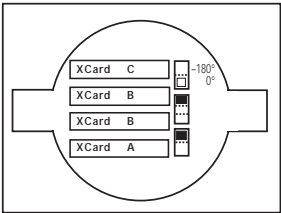

360.6 INSTALLATION



Power Connections (Option #1)

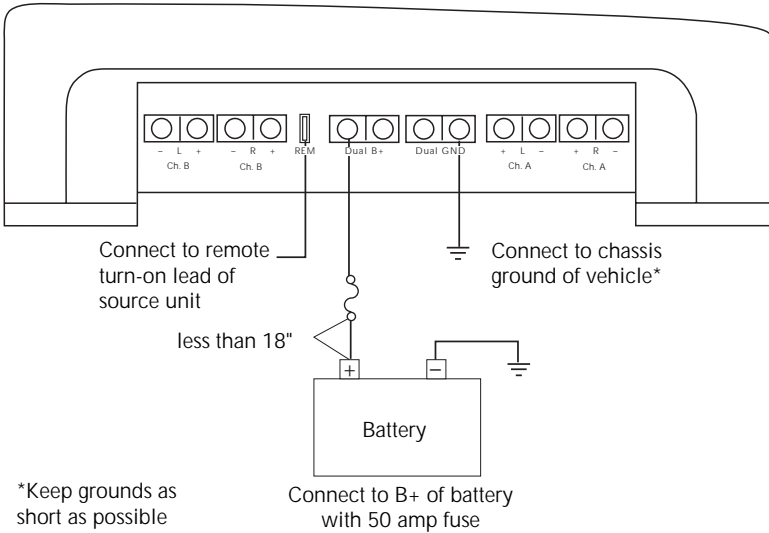

Power Connections (Option #2)

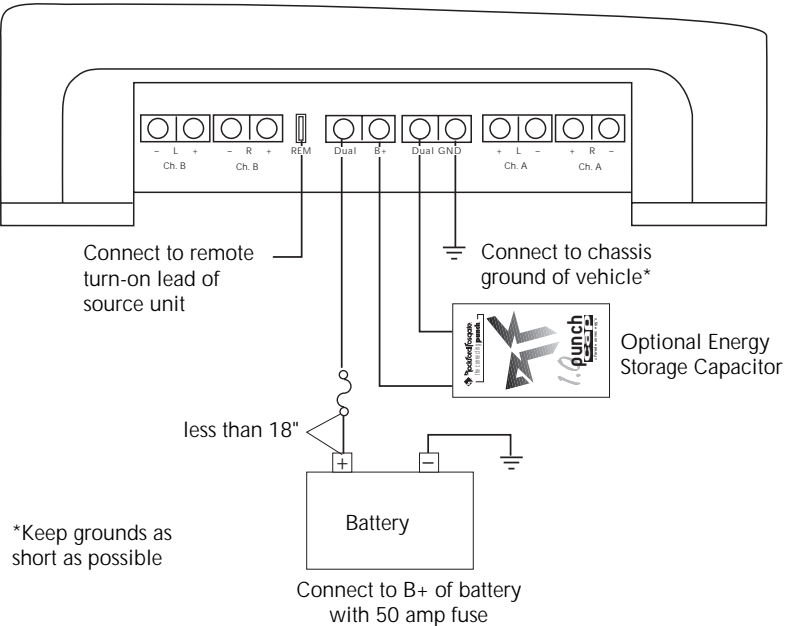



3-Channel Operation

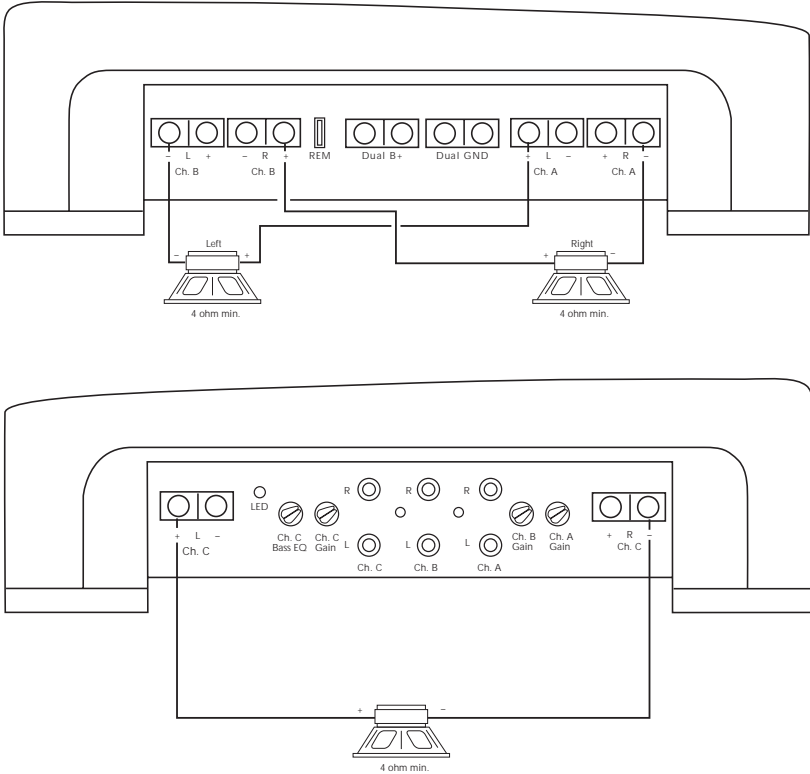

- **Gain Control** for channels A & B set *equally* to balance the left and right speakers
- **Gain Control** for channel C operates *independently*
- **Impedance Load** for bridged left channel should be **4Ω minimum**
- **Impedance Load** for bridged right channel should be **4Ω minimum**
- **Impedance Load** for bridged C channel should be **4Ω minimum**
- **XCards A & B** set identically as 12dB High-Pass, 12dB Low-Pass or Full Range
- **XCard C** can be set for High-Pass, Low-Pass or Full Range



3-Channel Mono Operation

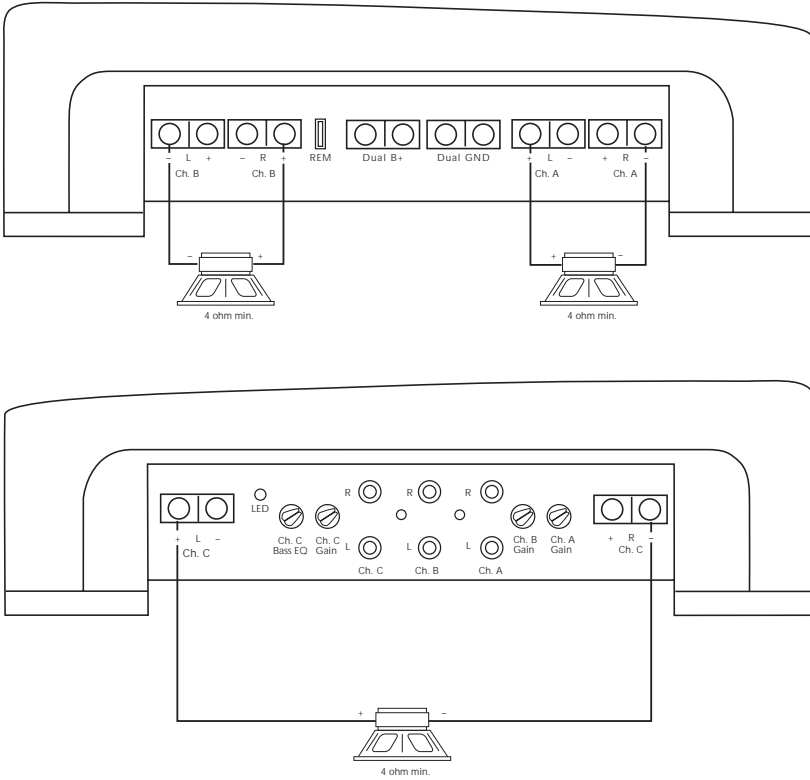

- **Gain Control** for channels A, B & C operate *independently*
- **Impedance Load** for bridged channel A should be *4Ω minimum*
- **Impedance Load** for bridged channel B should be *4Ω minimum*
- **Impedance Load** for bridged channel C should be *4Ω minimum*
- **XCard A** can be set for High-Pass, Low-Pass or Full Range
- **XCard B** can be set for 12dB High-Pass, 12dB Low-Pass or Full Range
- **XCard C** can be set for High-Pass, Low-Pass or Full Range



4-Channel Stereo Operation

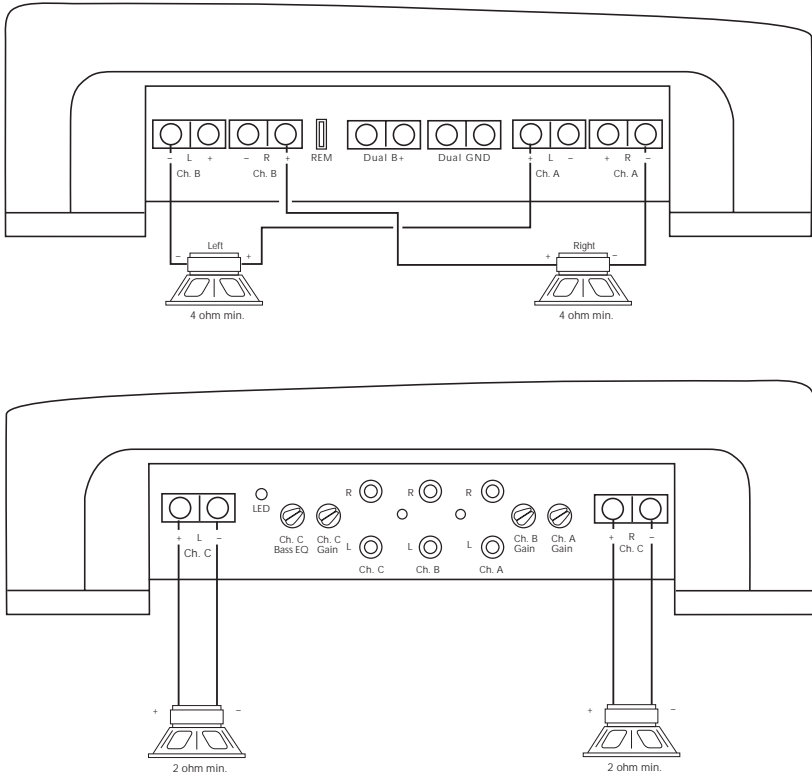

- **Gain Control** for channels A & B *set equally*
- **Gain Control** for channel C operates *independently*
- **Impedance Load** for bridged left channel should be **4Ω minimum**
- **Impedance Load** for bridged right channel should be **4Ω minimum**
- **Impedance Load** for stereo channel C should be **2Ω minimum**
- **XCards A & B** set identically as 12dB High-Pass, 12dB Low-Pass or Full Range
- **XCard C** can be set for High-Pass, Low-Pass or Full Range

5-Channel Operation

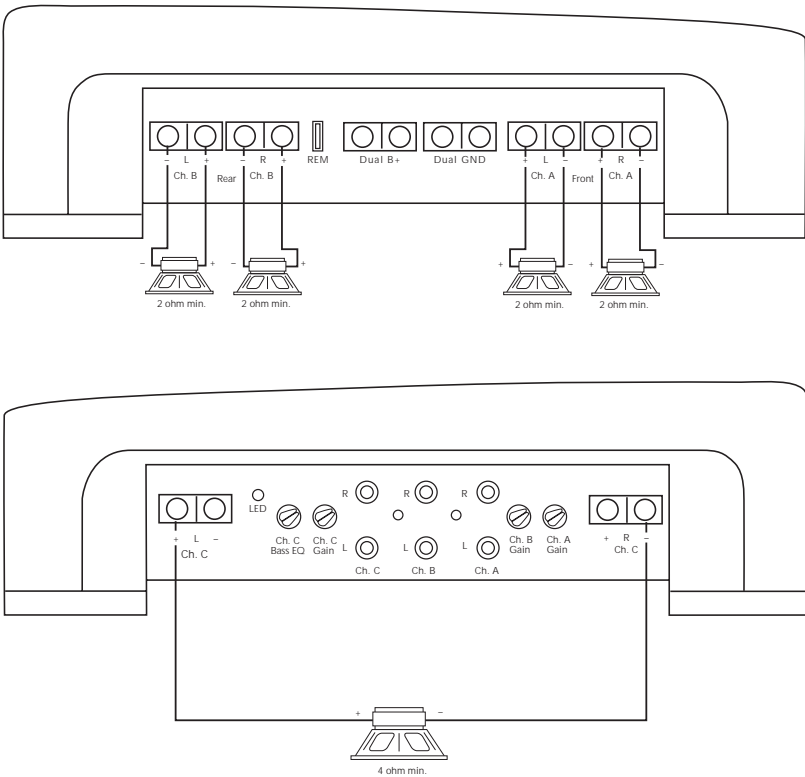

- **Gain Controls** for channels A, B & C operate *independently*
- **Impedance Load** for stereo channel A should be 2Ω *minimum*
- **Impedance Load** for stereo channel B should be 2Ω *minimum*
- **Impedance Load** for bridged channel C should be 4Ω *minimum*
- **XCard A** can be set for High-Pass, Low-Pass or Full Range
- **XCard B** can be set for 12dB/24dB High-Pass, 12dB/24dB Low-Pass 12dB Bandpass or Full Range
- **XCard C** can be set for High-Pass, Low-Pass or Full Range

6-Channel Stereo Operation

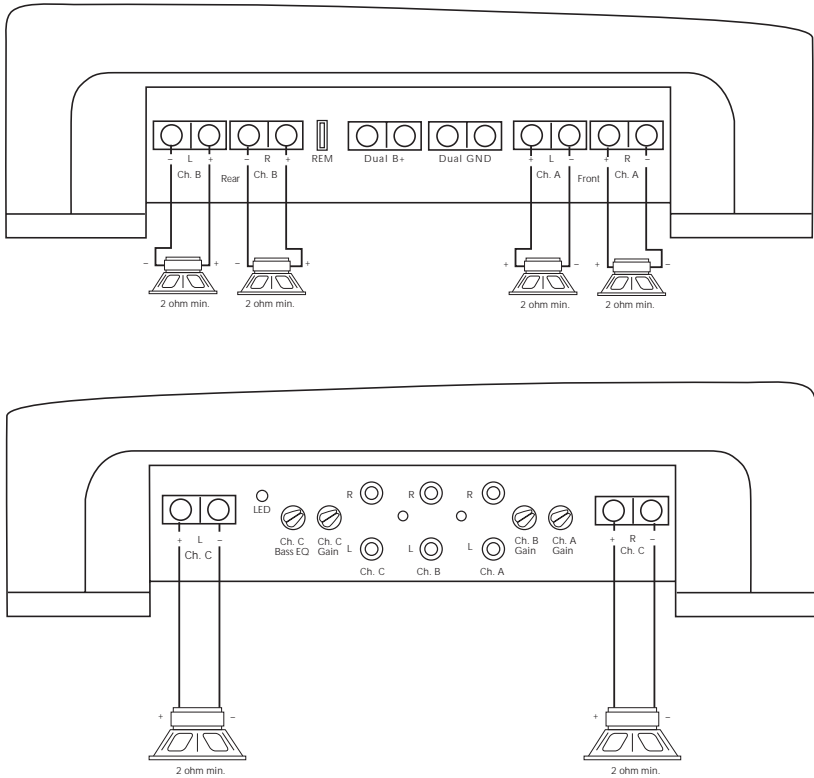

- **Gain Control** for channels A, B & C operate *independently*
- **Impedance Load** for stereo channels A, B & C should be **2Ω minimum**
- **XCard A** can be set for High-Pass, Low-Pass or Full Range
- **XCard B** can be set for 12dB/24dB High-Pass, 12dB/24dB Low-Pass 12dB Bandpass or Full Range
- **XCard C** can be set for High-Pass, Low-Pass or Full Range

360.6 SYSTEM DIAGRAMS

Bridged Left & Right w/Bridged Subwoofer

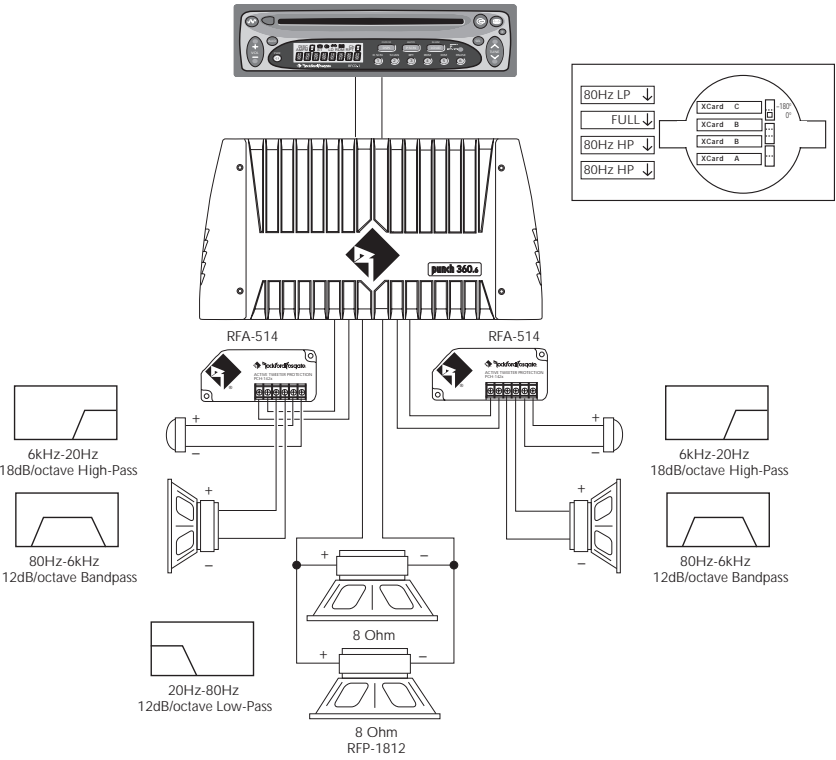

Front & Rear w/Bridged Subwoofer

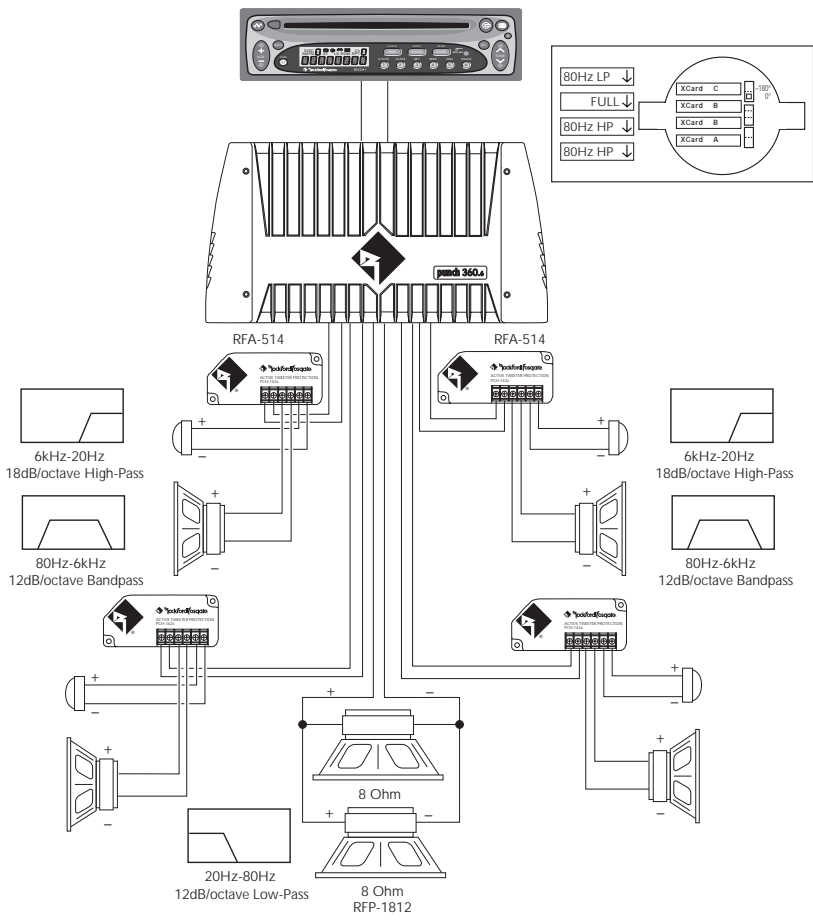

Front & Rear w/Bridged Subwoofer

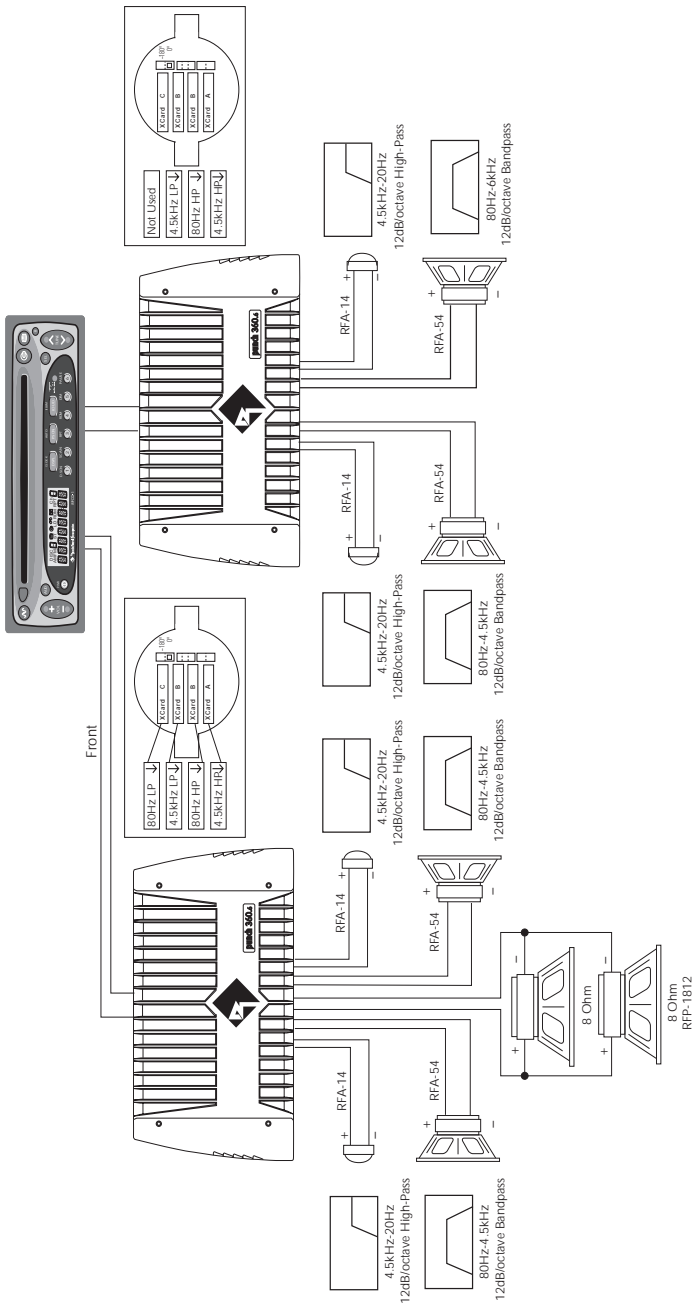

Front & Rear w/Midbass and Bridged Subwoofer

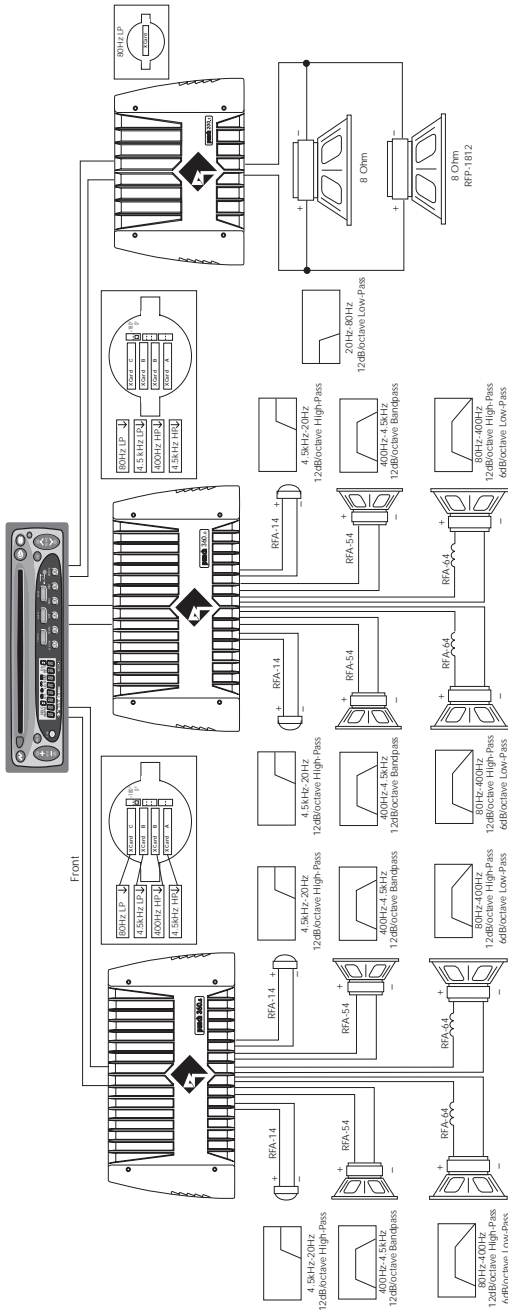

TROUBLESHOOTING



Symptom	Diagnosis	Remedy
Amplifier does not turn on (Power LED is off)	Voltage applied to the REM terminal of the amplifier is not between 10.5 and 15.5 volts or there is no voltage present.	Check the alternator, battery, fuse, and wiring and repair as necessary. If the voltage is above 15.5 volts, have the electrical system inspected by an authorized car service center.
	Voltage to the B+ terminal of the amplifier is not between 10.5 and 15.5 volts or there is no voltage present.	Check the alternator, battery, fuse, and wiring and repair as necessary. If the voltage is above 15.5 volts, have the electrical system inspected by an authorized car service center.
	Amplifier is not properly grounded.	Check wiring and repair as necessary.
Amplifier has no sound (Power LED is on)	RCA Input from source unit is not connected or not functioning properly.	Check connections, substitute with known working source and cables and repair or replace as necessary.
	XCard is missing or not placed properly in crossover slots.	Check XCard position and repair or replace as necessary.
	Speaker leads are shorted to each other or to the chassis of the vehicle.	Disconnect existing speakers and test with known working speakers and wires. If amplifier plays, check and repair wiring and installation of speakers as necessary.
	Speakers are defective.	Disconnect existing speakers and test with known working speakers. If amplifier plays, check and repair speakers as necessary.



Symptom	Diagnosis	Remedy
Speaker Output Low or Distorted	Input gain signal for amplifier is incorrectly set.	Readjust input gains of amplifier.
	Source unit output too low or source unit has no output.	Check system with known working source and repair or replace original source as needed.
	XCard is missing or not placed properly in cross-over slots.	Check XCard position and repair or replace as necessary.
	Low battery voltage or large voltage drops to the amplifier under load.	Check the alternator, battery, fuse, and power and ground wiring. Repair as necessary.
No Output on Channel A, Channel B, or Channel C	Signal Input Switches not configured properly.	Check Signal Input Switches and reconfigure as necessary.
	XCard(s) missing or not placed properly in cross-over slot.	Check XCard position(s) and repair or replace as necessary.
Low Output on Channel C (L mono RCA input)	Signal Input Switches do not configure Channel C for E-Z Bridge.	Check Signal Input Switches and reconfigure as necessary.
Amplifier Noise (Turn-on pop)	Voltage spike from output of preceding component is entering amplifier through input signal.	Disconnect input signal to amplifier and turn amplifier on and off. If noise is eliminated, connect REM lead of amplifier to source unit with a delay turn-on module.
	Voltage spike from remote turn-on lead is entering through REM input terminal.	Use a different 12 volt source for REM lead of amplifier. (i.e., battery direct) If noise is eliminated, use a relay to isolate amplifier from noisy turn-on output.



Symptom	Diagnosis	Remedy
Engine Noise	Noise is radiating into RCA signal cable.	Check connections, run the RCA cables on a different route away from sources of high current.
	Bad component in the signal chain.	Check connections, bypass additional components (crossovers and equalizers) between the source unit and the amplifier. Connect one component at a time to determine the culprit. Repair or replace components as necessary.
	Noise is radiating into speaker cables.	Disconnect existing speakers and connect a test speaker to the output terminals of the amplifier. If noise is gone, reroute the speaker cables away from sources of high voltage.
	Multiple grounds in the audio system.	Check ground connections and connect amplifiers, signal processors, and other components to a central location or try a different grounding point on the chassis.
	Ground loop between source unit and antenna.	Check connections, disconnect antenna from source unit. If noise is gone, install an antenna ground loop isolator.

- If noise persists, see your Authorized Rockford Fosgate Dealer.

DYNAMIC POWER MEASUREMENTS

About the Dynamic Power Measurements

The Audio Graph PowerCube is a test instrument used to measure the output of an amplifier in accordance with IHF-202 industry standards. The IHF-202 standard is a dynamic power measurement and was developed as a means of measuring power in a manner that best represents the Real World operation of an amplifier. Many manufacturers, including Rockford Fosgate, at times will measure amplifier power into a fixed resistor (4 ohm, 2 ohm). While this method is useful in some types of evaluation and testing, it is not representative of an amplifier that is connected to a speaker and playing music.

Music

Music is dynamic; the sound waves are complex and constantly changing. In order to simulate this, the IHF-202 standard calls for the input signal to the amplifier to be a 1kHz burst tone. This signal is input (on for 20 milliseconds) and reduced 20dB for 480 milliseconds. The signal is gradually increased in level until the amplifier's output exceeds 1% Total Harmonic Distortion (THD). At 1% distortion becomes audible, therefore, any power produced above that level is considered *unusable*. Many manufacturers represent their amplifiers' output power in excess of 10% distortion. They use many names for this measurement, such as Total Maximum Power or Maximum Output Power. This is not indicative of the *actual usable output power*.

Listening to Loudspeakers - Not Resistors

A loudspeaker is not a resistor. A resistor's value (resistance measured in ohms) is fixed. A loudspeaker's impedance is dynamic. It is constantly changing in value, dependent upon the frequency of the input signal. Therefore, measuring power with the amplifier loaded into a 4 ohm resistor is not the same as measuring power with the amplifier connected to a 4 ohm speaker. Most people do not listen to music through a resistor.

A 4 ohm speaker may experience a drop in impedance 4-6 times lower than its nominal (printed) impedance. A speaker will also create phase shifts in the signal that is passed through it. These phase shifts happen because a speaker is an inductor (voice coil) and a capacitor (compliance of the surround/spider), as well as a resistor (voice coil wire).

To simulate a speaker the Audio Graph PowerCube measures output power into 20 different loads. It tests at 8 ohms, 4 ohms, 2 ohms and 1 ohm. Each of these impedances is also tested at -60° , -30° , 0° , $+30^\circ$ and $+60^\circ$ phase angles. These different impedances and phase angles represent the shifts in impedance and phase that can occur in a typical loudspeaker.

Information Cubed

The data acquired in the testing procedure is then graphed in the form of a 3-dimensional cube, hence the name **PowerCube**.

The *Phase Angle* is expressed on the horizontal axis, the *Output Voltage* is presented on the vertical axis and the *Impedance* is displayed on the Z axis. *Output Power*, in watts, is listed on the left hand side for each impedance at each phase angle.

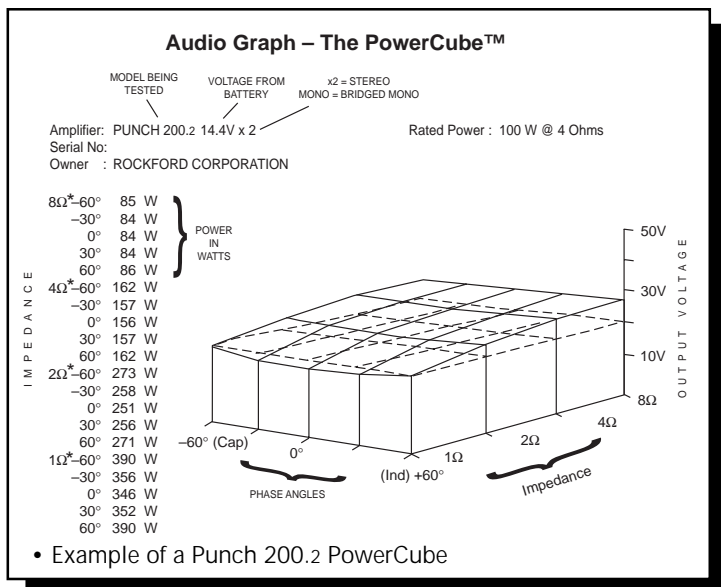

What is an Amplifier?

An amplifier by definition is a voltage generating device, recreating the signal which is input to it identically but with increased volume. It will be connected to a reactive load (the speaker). The impedance of this load and phase of the signal passing through the load will vary, dependent upon the frequency of the input signal (music).

Therefore, a perfect amplifier will be able to maintain the same output voltage regardless of load characteristics and will not alter the signal it is reproducing. A perfect amplifier when measured by the Audio Graph PowerCube would present data that forms a perfect cube. Unfortunately, amplifiers are not perfect. The laws of physics generally prevent it. A great amplifier is about the best one can hope to attain.

As you can see by the PowerCube and as you will experience by listening, your Punch amplifier is a GREAT AMPLIFIER!

SPECIFICATIONS

Continuous Power Rating (Competition Standard) - Measured at 13.8 Battery Volts

RMS continuous power **per channel**, 30 Watts x 6
all channels driven into a 4 Ω load
from 20 to 20,000 Hz with less than
0.05% Total Harmonic Distortion (THD)

RMS continuous power **per channel**, 60 Watts x 6
all channels driven into a 2 Ω load
from 20 to 20,000 Hz, with less than
0.1% Total Harmonic Distortion (THD)

RMS continuous power **bridged** into a 120 Watts x 3
4 Ω load from 20 to 20,000 Hz, with
less than 0.1% Total Harmonic Distortion (THD)

Dynamic Power Rating (IHF-202 Standard) - Measured at 14.4 Volts
Per channel into a 4 Ω Load 60 Watts x 6
Per channel into a 2 Ω Load 95 Watts x 6
Bridged into a 4 Ω Load 190 Watts x 3

Signal-to-Noise Ratio > 100dB A-weighted
Frequency Response 20Hz-20kHz \pm 0.5dB
Bandwidth 10Hz-250kHz \pm 3dB
Damping Factor @ 4 Ω >200 (at output connector)
Slew Rate 30 V/ μ s
IM Distortion (IHF) <0.05%
Input Impedance 20k Ohms
Input Sensitivity Variable from 300mV to 5V
Preset at the factory for 500mV
B+ Fuse Size (External to Amplifier) 50 amp or two 25 amp
Fuse Type AGU
Crossover Alignment 12dB/octave Butterworth
(XCard C) = 80Hz (.047 μ f)
(XCard B) = 4.5kHz (.022 μ f)
(XCard B) = 80Hz (.047 μ f)
(XCard A) = 80Hz (.047 μ f)
Dimensions (including end caps) 9⁵/₈"H x 18⁹/₃₂"W x 2⁵/₈"D
(24.45cm x 46.43cm x 6.67cm)

WARRANTY INFORMATION

Rockford Corporation offers a limited warranty on Rockford Fosgate products on the following terms:

- **Length of Warranty**

3 years on electronics	90 days on electronic B-stock (receipt required)
2 years on source units	30 days on speaker B-stock (receipt required)

- **What is Covered**

This warranty applies only to Rockford Fosgate products sold to consumers by Authorized Rockford Fosgate Dealers in the United States of America or its possessions. Product purchased by consumers from an Authorized Rockford Fosgate Dealer in another country are covered only by that country's Distributor and not by Rockford Corporation.

- **Who is Covered**

This warranty covers only the original purchaser of Rockford product purchased from an Authorized Rockford Fosgate Dealer in the United States. In order to receive service, the purchaser must provide Rockford with a copy of the receipt stating the customer name, dealer name, product purchased and date of purchase.

- **Products found to be defective** during the warranty period will be repaired or replaced (with a product deemed to be equivalent) at Rockford's discretion.

- **What is Not Covered**
 1. Damage caused by accident, abuse, improper operations, water, theft
 2. Any cost or expense related to the removal or reinstallation of product
 3. Service performed by anyone other than Rockford or an Authorized Rockford Fosgate Service Center
 4. Any product which has had the serial number defaced, altered, or removed
 5. Subsequent damage to other components
 6. Any product purchased outside the U.S.
 7. Any product not purchased from an Authorized Rockford Fosgate Dealer

- **Limit on Implied Warranties**

Any implied warranties including warranties of fitness for use and merchantability are limited in duration to the period of the express warranty set forth above. Some states do not allow limitations on the length of an implied warranty, so this limitation may not apply. No person is authorized to assume for Rockford Fosgate any other liability in connection with the sale of the product.

- **How to Obtain Service**

Please call 1-800-669-9899 for Rockford Customer Service. You must obtain an RA# (Return Authorization number) to return any product to Rockford Fosgate. You are responsible for shipment of product to Rockford.

Ship to:
Electronics
Rockford Corporation
Warranty Repair Department
2055 E. 5th Street
Tempe, AZ 85281
RA#: _____

Ship to:
Speakers
Rockford Acoustic Design
(Receiving-speakers)
609 Myrtle N.W.
Grand Rapids, MI 49504
RA#: _____



LEA DETENIDAMENTE LAS SIGUIENTES INSTRUCCIONES DE INSTALACION DEL PRODUCTO. EVITARA POSIBLES DAÑOS A VD., AL VEHICULO O AL PRODUCTO.

INTRODUCCION

El Punch 360.6 es un amplificador de 6 canales de 360 vatios con características integradas para permitir diseños de sistemas con un solo amplificador. Dentro del amplificador hay 4 crossovers XCards y un circuito de conmutación de señal. Estos dispositivos simplifican el procesado de señal y permiten una distribución de la señal a medida de las necesidades para cada canal. También están integrados un conmutador de fase y un circuito ecualizador de graves diseñados para optimizar el ajuste del sistema. El esfuerzo de ingeniería realizado en el diseño del Punch 360.6 se hace patente al ver la facilidad con que es instalado un sistema de tres vías usando un mínimo número de componentes.

UBICACIÓN PARA EL MONTAJE

Montaje en el Malatero

Monte el amplificador verticalmente con las líneas del radiador orientadas de arriba hacia abajo. De esta manera conseguira la mejor ventilacion.

Montaje en el Compartimento de Pasajeros

El montaje en el compartimento de pasajeros sera eficiente en funcion de la ventilacion que tenga el amplificador. Si va a instalar el amplificador bajo un asiento deberá dejar al menos 2.5cm libres sobre la carcasa del amplificador.

Instalacion

Por seguridad, desconecte el terminal negativo de la bateria antes de comenzar la instalacion.

Terminal B+

El cable B+ debe ir provisto de un fusible a una distancia no mayor de 45cm de la bateria. Prepare el cable e instale el portafusibles en el compartimento del motor. Las conexiones han de ser impermeables.

Terminal GND

Prepare un trozo de cable para usarlo como toma de masa. Prepare un punto de masa en el chasis rascando y eliminando la pintura de la superficie de metal y limpielo de toda suciedad asegure el cable al chasis con un tornillo.

Terminal REM

Conecte el cable REM a un punto de +12V con mutable. La señal se suele coger de la salida auto antena del radio cassette si este no tiene salida remote.

UTILIZACION DEL CIRCUITO DE CONMUTACION DE SEÑAL

El circuito de conmutación de señal permite distribuir las entradas RCA a las salidas de varias diferentes maneras. **La orientación de ambos conmutadores configura la distribución de señal.** Los conmutadores pueden ser posicionados en las siguientes configuraciones.

Configuración n°1

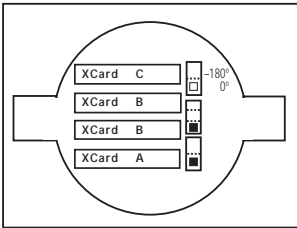

Entrada canal **A** => Salida canal **A**
Entrada canal **B** => Salida canal **B**
Canal **A y B sumados** => Salida canal **C**

Configuración n°2

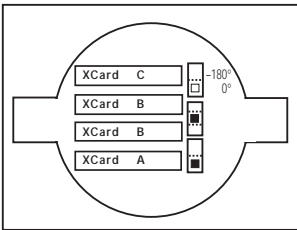

Entrada canal **A** => Salida canal **A**
Entrada canal **B** => Salida canal **B**
Entrada canal **C** => Salida canal **C**

Configuración n°3 Canal C puente

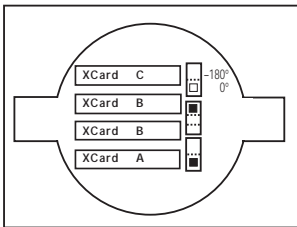

Entrada canal **A** => Salida canal **A**
Entrada canal **B** => Salida canal **B**
Entrada canal **C (mono)** => Salida canal **C**

Configuración n°4

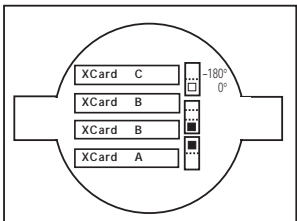

Entrada canal **A** => Salida canal **A, B y C**

Configuración nº5

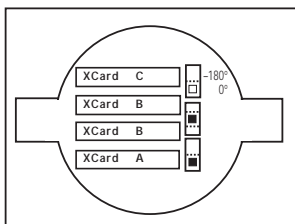

Entrada canal **A** => Salida canal **A y B**
Entrada canal **C** => Salida canal **C**

Configuración nº6 Canal C puente

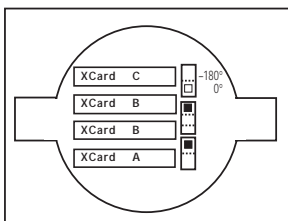

Entrada canal **A** => Salida canal **A y B**
Entrada canal **C (mono)** => Salida canal **C**

Funcionamiento en tres canales

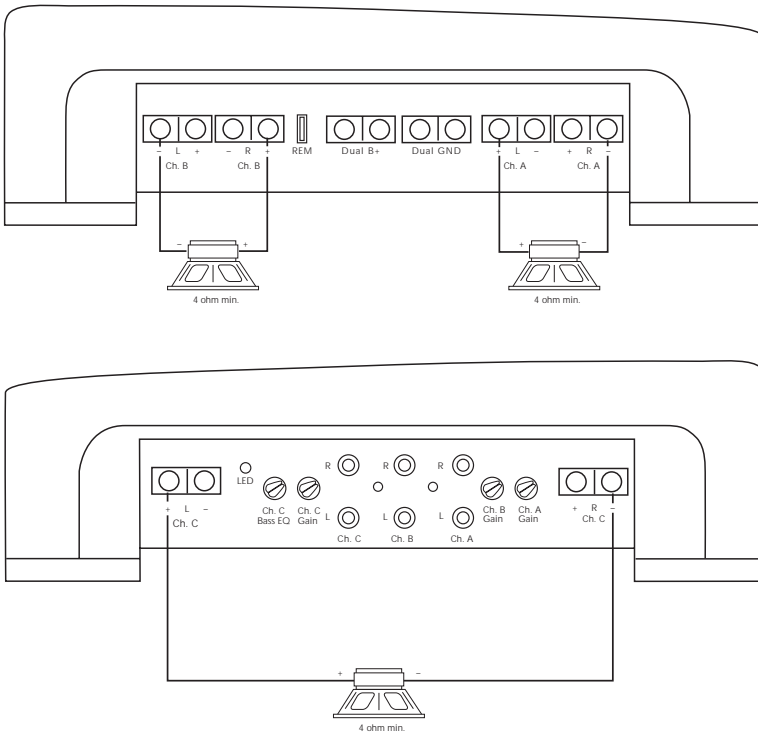

- Las **ganancias** de los canales A y B han de ser fijadas *igual* para igualar los canales
- La **ganancia** del canal C funciona *independientemente*
- La **impedancia** del canal izquierdo puentado no debe ser menor de 4Ω
- La **impedancia** del canal derecho puentado no debe ser menor de 4Ω
- Las **XCards para A y B** han de ser iguales y fijadas en 12dB HP, 12dB LP o Full Range
- La **XCard C** puede fijarse en cualquier posición

Funcionamiento en 6 canales Estereo

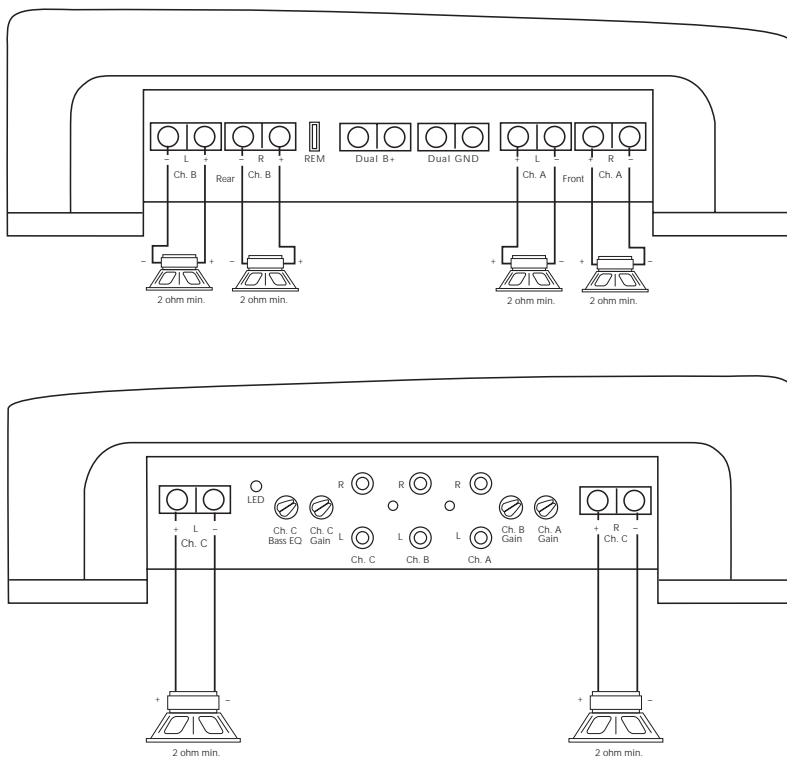

- **L Ganancia** de los canales A, B y C funcionan *independientemente*
- **La Impedancia** para los canales A, B y C estereo no debe ser menor de 2Ω
- **La XCard A** se puede posicionar en HP, LP o Full Range
- **La XCard B** se puede fijar en 12dB/24dB HP, 12dB/24dB LP o 12dB Bandpass o Full Range
- **La XCard C** se puede posicionar en HP, LP o Full Range

ATTENTION: Veuillez lire les instructions suivantes pour l'installation de cet amplificateur. Ne pas les suivre pourrait causer des blessures ou endommager le véhicule.

INTRODUCTION

Le Punch 360.6, est un amplificateur à 6 canaux de 360 watts avec des caractéristiques reprises aux amplificateurs 2 canaux. Quatre cartes de filtrage sont intégrées dans l'ampli ainsi qu'un réseau de commutation du signal. Ces caractéristiques simplifient le traitement du signal et permettent une configuration personnalisée de la distribution du signal à chaque paire de canaux. Afin d'améliorer le réglage de votre système nous avons également intégré un commutateur de phase et un circuit d'égalisation des basses. Le développement du Punch 360.6 montre à quel point un système 3 voies de qualité peut être facilement installé tout en utilisant un minimum de composants.

FRANÇAIS

MONTAGE

Montage dans le coffre

Monter l'amplificateur verticalement avec les rainures de haut en bas ce qui lui permet de refroidir plus facilement.

Montage dans l'habitacle

Monter l'amplificateur dans l'habitacle ne pose aucun problème, du moment qu'il y ait assez d'air pour le refroidir. Si vous montez l'ampli en dessous du siège, prévoyez 3 cm d'air autour du radiateur.

Installation

Pour votre sécurité, déconnectez la borne négative de la batterie du véhicule avant de commencer l'installation.

Terminal B+

Il est impératif qu'il y ait un fusible sur le câble pour la connexion à la masse. Préparez le châssis en grattant la peinture de la surface métallique et nettoyez la saleté et l'huile. Attachez le câble au châssis avec une vis.

Terminal GND

Préparez une longueur de câble pour la connexion à la masse. Préparez le châssis en grattant la peinture de la surface métallique et nettoyez la saleté et l'huile. Attachez le câble au châssis avec une vis.

Terminal REM

Connectez le fil REM à une commande 12 volts positive de la source. La commande 12 volts est habituellement prise sur la sortie antenne électrique de la source ou la commande accessoire. Si la source ne dispose pas de ces sorties, nous vous recommandons d'installer un interrupteur qui fournira un positif 12 volts au REM de l'amplificateur.

UTILISATION DU RÉSEAU DE COMMUTATION DU SIGNAL

Le réseau de commutation du signal permet au signal provenant des RCA e'entrée d'être distribué vers les sorties dans de multiple configurations. **L'orientation des deux commutateurs configure la distribution de signal.** Les commutateurs peuvent être orientés afin d'obtenir les configurations suivantes:

Configuration #1

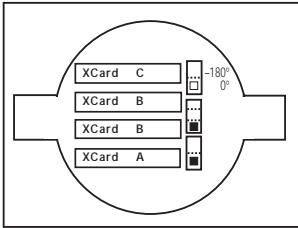

entrée **A** => sortie **A**
 entrée **B** => sortie **B**
 somme des entrées **A** et **B** => sortie **C**

Configuration #2

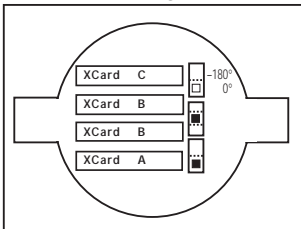

entrée **A** => sortie **A**
 entrée **B** => sortie **B**
 entrée **C** => sortie **C**

Configuration #3
 (E-Z bridge canal C)

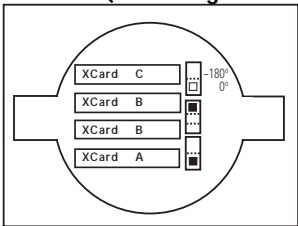

entrée **A** => sortie **A**
 entrée **B** => sortie **B**
 entrée **C** (L mono) => sortie **C**

Configuration #4

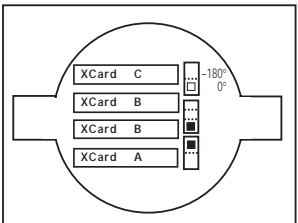

entrée **A** => sortie **A, B** et **C**

Configuration #5

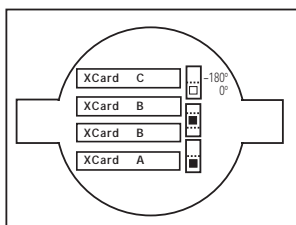

entrée **A** => sortie **A** et **B**
entrée **C** => sortie **C**

Configuration #6 (E-Z bridge canal C)

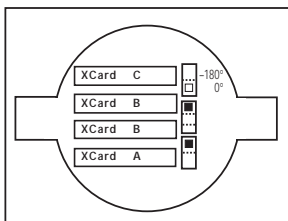

entrée **A** => sortie **A** et **B**
entrée **C** (L mono) => sortie **C**

Configuration à 3 canaux

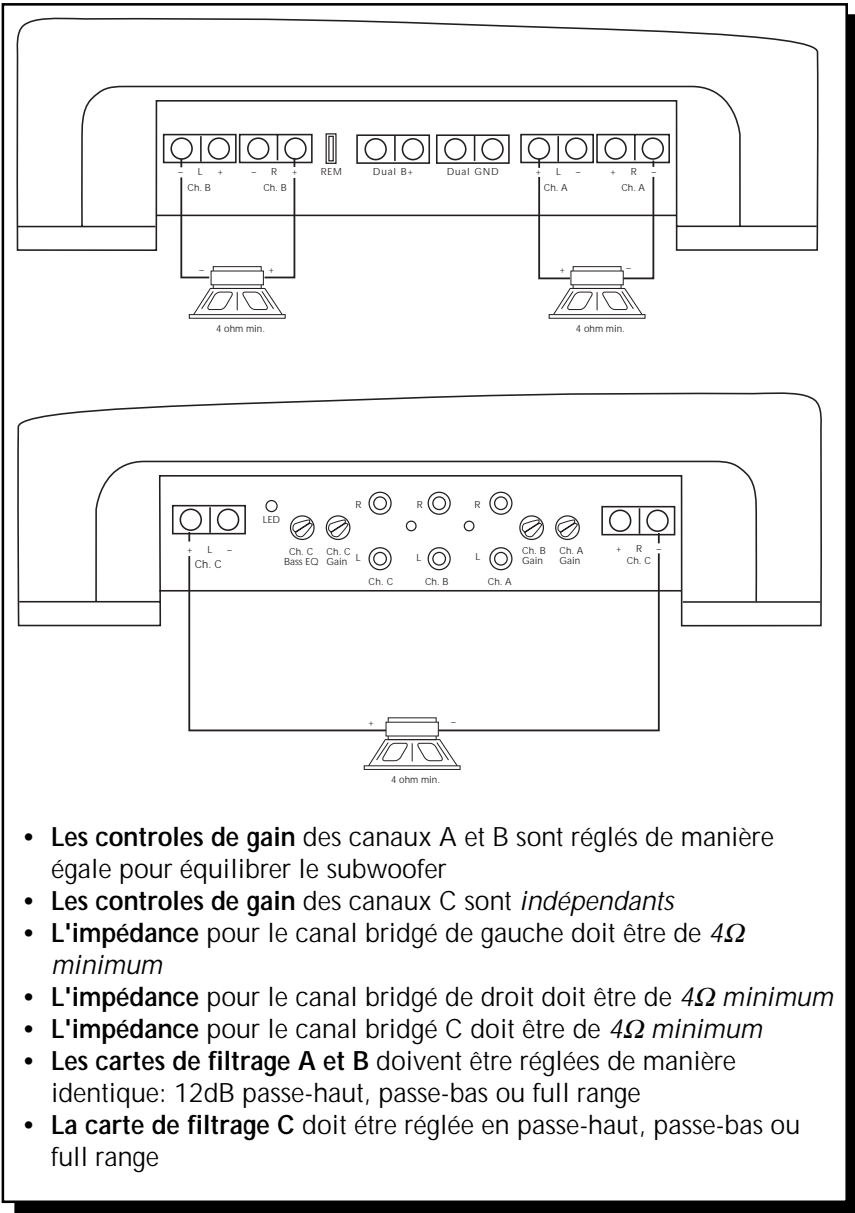

- **Les controles de gain** des canaux A et B sont réglés de manière égale pour équilibrer le subwoofer
- **Les controles de gain** des canaux C sont *indépendants*
- **L'impédance** pour le canal bridgé de gauche doit être de **4Ω minimum**
- **L'impédance** pour le canal bridgé de droit doit être de **4Ω minimum**
- **L'impédance** pour le canal bridgé C doit être de **4Ω minimum**
- **Les cartes de filtrage A et B** doivent être réglées de manière identique: 12dB passe-haut, passe-bas ou full range
- **La carte de filtrage C** doit être réglée en passe-haut, passe-bas ou full range

Configuration à 6 canaux

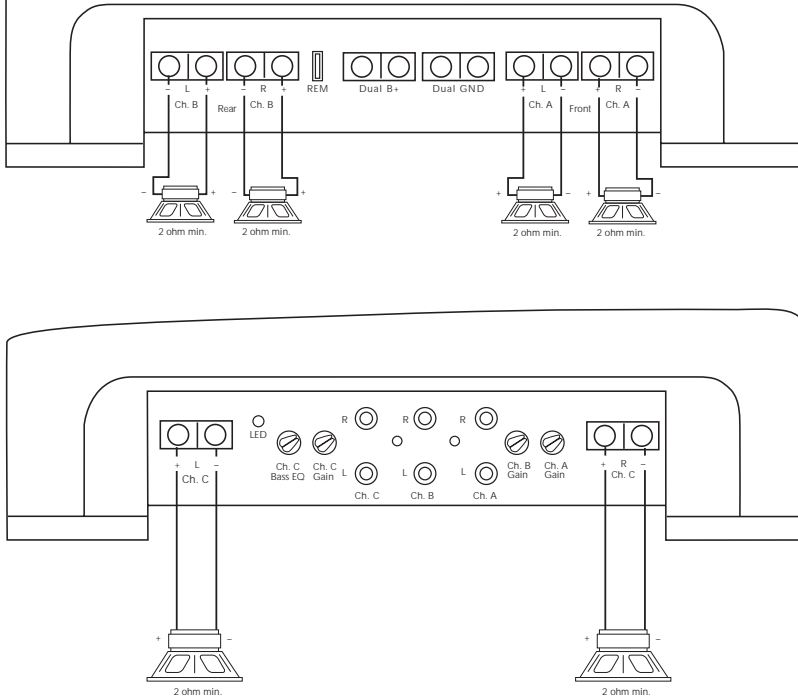

- **Les controles de gain** des canaux A, B et C sont *indépendants*
- **L'impédance** pour le canal bridgé de gauche doit être de **4Ω minimum**
- **L'impédance** pour le canal bridgé de droit doit être de **4Ω minimum**
- **La carte de filtrage A** peut être réglée en passe-haut, passe-bas ou full range
- **Les cartes de filtrage B** peuvent être réglées en 12/24dB passe-haut, 12/24dB passe-bas, 12dB passe-bande ou full range
- **La carte de filtrage C** peut être réglée en passe-haut, passe-bas ou full range

BITTE LESEN SIE DIESE GEBRAUCHSANLEITUNG ZUERST SORGFÄLTIG DURCH. DAS KANN SIE VOR DEM FALSCHEN EINSATZ, AUSFALLEN ODER SOGAR BESCHÄDIGUNG DES PRODUKTES ODER IHRES FAHRZEUGES SCHÜTZEN.

EINLEITUNG

Die Punch 360.6 ist ein 360 Watt, 6-Kanal Verstärker mit integrierten Besonderheiten, um ein "ein Verstärker" System zu kreieren. Eingebaut sind vier interne Frequenzkarten und ein schaltbares Signal Netzwerk. Diese Besonderheiten vereinfachen die Signalbearbeitung und ermöglichen es, jedem Kanal die "richtigen" Frequenzen zuzuteilen. Ein Phasenumschalter und eine Bass-Equilizer Schaltung sind ebenfalls eingebaut, um Ihr System optimal anzupassen. Die Anstrengungen der Ingenieure lagen darin, ein vollwertiges 3-Wege System mit möglichst wenig Komponenten zu realisieren.

EINBAUORT

Im Fahrzeugkofferraum

Der vertikale Einbau der Endstufen, das bedeutet, daß die Kühlrippen von oben nach unten verlaufen, gibt dem Verstärker die beste Kühlung.

Auf der Beifahrerseite

Sollte der Verstärker auf der Beifahrerseite montiert werden, so ist es sehr wichtig, für eine ausreichende Kühlung zu sorgen. Sollte der Verstärker z.B. unter dem Beifahrersitz montiert werden, sollte dem Kühlkörper mindestens ein Luftspalt von 3 cm bleiben, um so für eine ausreichende Kühlung zu sorgen.

Einbau

Zur Sicherheit klemmen Sie den Negativ-Pol der Batterie während des gesamten Einbaues ab.

B+ Anschluss

Die Plus-Leitung MUß ca. 40 cm nach dem Plus-Pol der Batterie abgesichert sein. Preparieren Si die Kabellängen und montieren Sie den Sicherungshalter im Motorraum. ALLE Verbindungen müssen wasserdicht sein.

GND Anschluss

Preparieren Sie Ihr Kabel für die Negativ Leitung (Erdung). Preparieren Sie die Anschlußstelle des Erdungskabels, indem Sie das Metall gründlich reinigen und vom Lack befreien. Befestigen Sie nun die Erdung an dieser Stelle mit einer Schraube.

REM Anschluss

Verbinden Sie das Ein- und Ausschaltungskontroll-Kabel mit Ihrem Radio (12 Volt positiv). Normalerweise verwenden Sie hierfür die Ant.-Remote Ihres Radios oder ein eigens dafür vorgesehenes Kabel (Amp-Remote). Sollte Ihr Radio diesen Anschluß nicht besitzen, so verwenden Sie eine 12 Volt Spannung, die Sie durch einen Schalter ein- und ausschalten können.

BENUTZEN DES SIGNAL NETZWERKES

Das Schaltbare Signal Netzwerk erlaubt es, die Eingangssignale den verschiedenen Ausgängen optimal zuzuteilen. Die verschiedenen Stellungen der Schalter sind in den folgenden Beispielen dargestellt.

Beispiel #1

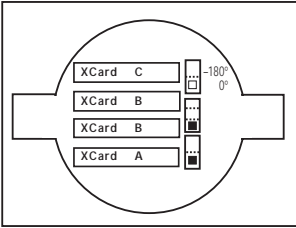

Kanal **A** Eingang => Kanal **A** Ausgang
 Kanal **B** Eingang => Kanal **B** Ausgang
 Kanal **A & B**
 Eingang addiert => Kanal **C** Ausgang

Beispiel #2

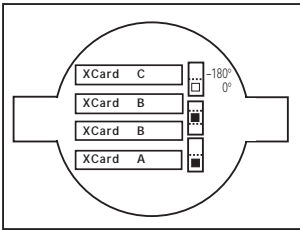

Kanal **A** Eingang => Kanal **A** Ausgang
 Kanal **B** Eingang => Kanal **B** Ausgang
 Kanal **C** Eingang => Kanal **C** Ausgang

Beispiel #3

(E-Z gebrückt Kanal C)

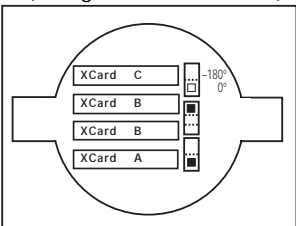

Kanal **A** Eingang => Kanal **A** Ausgang
 Kanal **B** Eingang => Kanal **B** Ausgang
 Kanal **C** (L mono) Eingang => Kanal **C** Ausgang

Beispiel #4

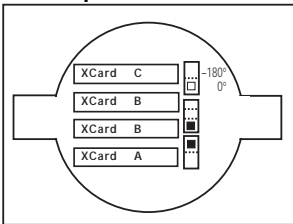

Kanal **A** Eingang => Kanal **A, B & C** Ausgang

DEUTSCH

Beispiel #5

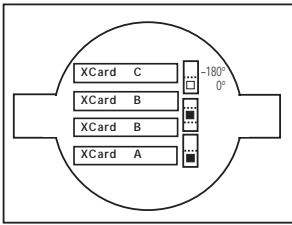

Kanal **A** Eingang => Kanal **A & B** Ausgang
Kanal **C** Eingang => Kanal **C** Ausgang

Beispiel #6

(E-Z gerbrückt Kanal C)

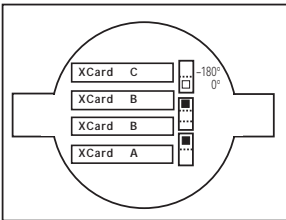

Kanal **A** Eingang => Kanal **A & B** Ausgang
Kanal **C** (L mono) Eingang => Kanal **C** Ausgang

3-Kanal Operation

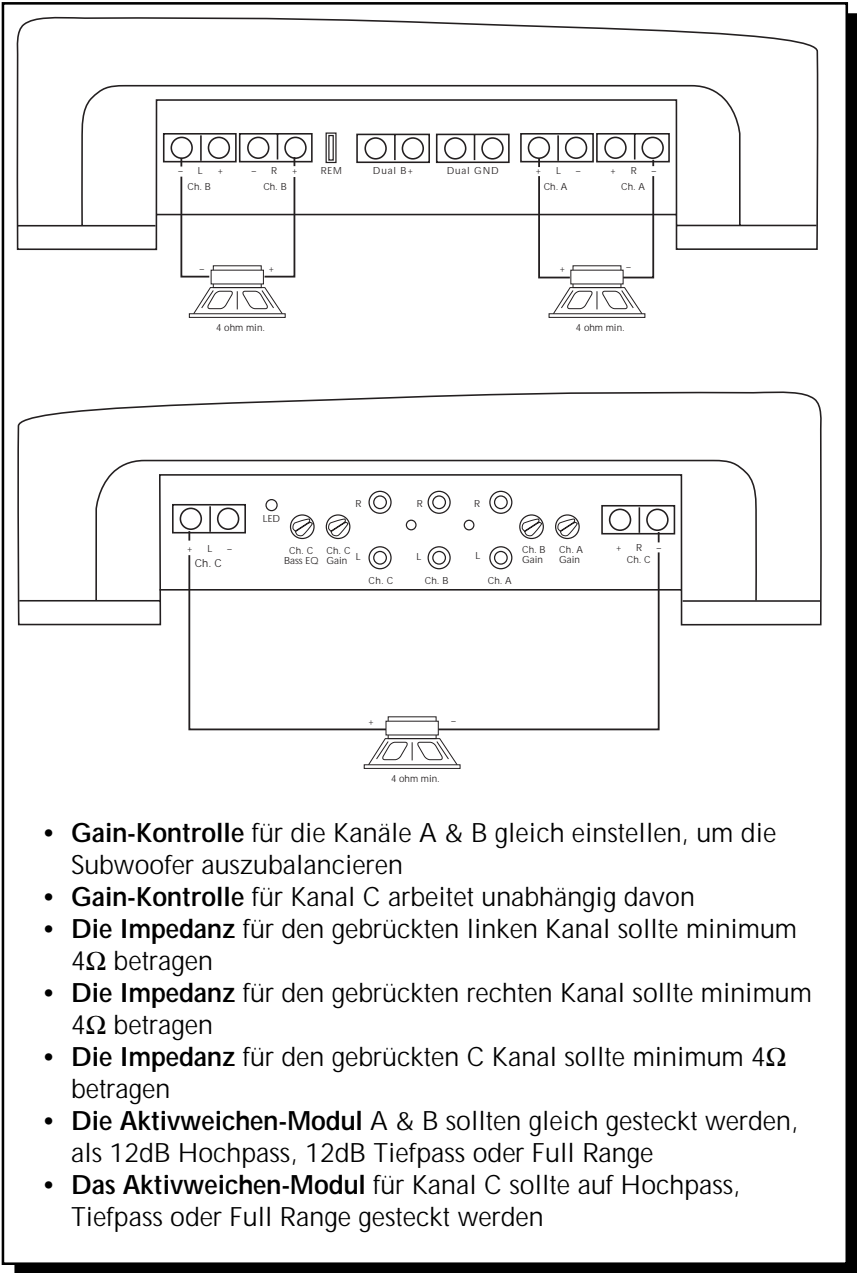

- **Gain-Kontrolle** für die Kanäle A & B gleich einstellen, um die Subwoofer auszubalancieren
- **Gain-Kontrolle** für Kanal C arbeitet unabhängig davon
- **Die Impedanz** für den gebrückten linken Kanal sollte minimum 4Ω betragen
- **Die Impedanz** für den gebrückten rechten Kanal sollte minimum 4Ω betragen
- **Die Impedanz** für den gebrückten C Kanal sollte minimum 4Ω betragen
- **Die Aktivweichen-Modul A & B** sollten gleich gesteckt werden, als 12dB Hochpass, 12dB Tiefpass oder Full Range
- **Das Aktivweichen-Modul** für Kanal C sollte auf Hochpass, Tiefpass oder Full Range gesteckt werden

6-Kanal Stereo Operation

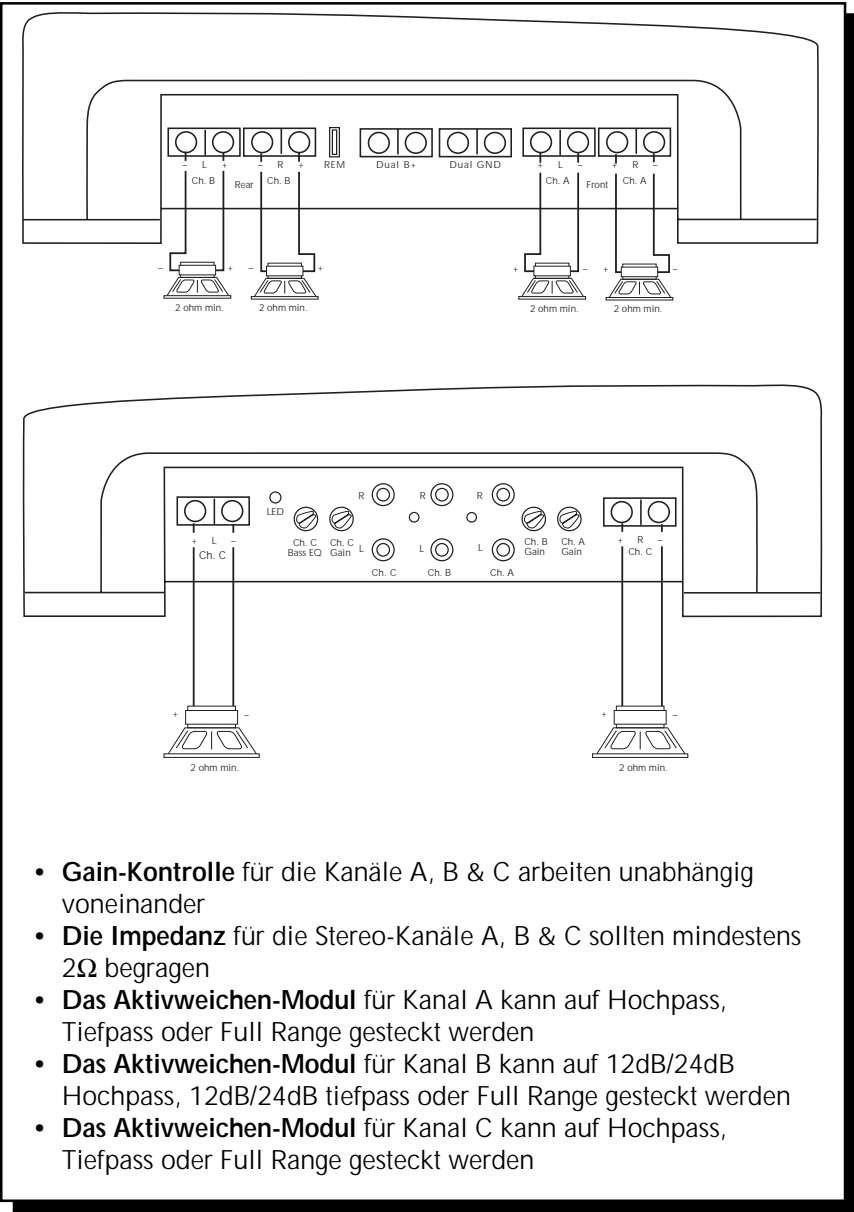

- **Gain-Kontrolle** für die Kanäle A, B & C arbeiten unabhängig voneinander
- **Die Impedanz** für die Stereo-Kanäle A, B & C sollten mindestens 2Ω betragen
- **Das Aktivweichen-Modul** für Kanal A kann auf Hochpass, Tiefpass oder Full Range gesteckt werden
- **Das Aktivweichen-Modul** für Kanal B kann auf 12dB/24dB Hochpass, 12dB/24dB tiefpass oder Full Range gesteckt werden
- **Das Aktivweichen-Modul** für Kanal C kann auf Hochpass, Tiefpass oder Full Range gesteckt werden

ATTENZIONE: SI PREGA DI LEGGERE LE SEGUENTI ISTRUZIONI PER L'INSTALLAZIONE DI QUESTO PRODOTTO. IL NON SEGUIRLE POTREBBE RISULTARE SERIAMENTE DANNOSO PER LA PERSONA O PER IL VEICOLO.

INTRODUZIONE

Il Punch 360.6 é un amplificatore da 360 watt totali e 6 canali progettato per essere installato come un singolo apparato. Al suo interno trovano posto caratteristiche che consentono questa elevatissima versatilità, come le 4 XCard e la rete di selezione degli ingressi. tutte queste caratteristiche semplificano il processo del segnale audio e permettono all'utilizzatore di smistare il segnale a ciascuna coppia di canali. É presente anche uno switch di inversione fase e un circuito di equalizzazione in gamma bassa per agevolare le operazioni di taratura del sistema. Lo sforzo ingegneristico applicato al 360.5 dimostra come un sistema a 3 vie possa essere installato con facilitá mantenendo ridotto il numero di componenti.

DOVE POSIZIONARLO

Nel Bagagliaio

Montando l'amplificatore su una superficie in verticale con le alette direzionate dall'alto verso il basso vi garantirá un miglior raffreddamento dell'amplificatore.

Nell'abitacolo

Montandop l'amplificatore nell'abitacolo si avrá un funzionamento regolare se si garantisce un flusso d'aria sufficiente. Per l'installazione sotto un sedile, é necessario avere uno spazio di almeno 3 cm attorno a tutto l'amplificatore.

Installazione

Per sicurezza, scollegare il polo negativo della batteria dell'auto prima di iniziare l'installazione.

Terminale B+ (cavo positivo)

Il cavo positivo deve essere protetto da un fusibile a non piú di 45 cm dalla batteria. Terminare il cavo e installare il fusibile nel vano motore. Tutte le connessioni devono essere a prova d'acqua.

Terminale GND (cavo negativo)

Decidere la lunghezza del cavo e terminarlo. Preparare la massa grattando la vernice dal telaio dell'auto ed eliminando tracce di olio o sporco. Fissare il cavo di massa al telaio con una vite.

Terminale REM (Consenso di accensione)

Collegare il cavo REM ad un positivo presente solo ad autoradio accesa (normalmente il cavo pilota dell'antenna elettrica o il cavo accessori dell'autoradio). Se la sorgente non dovesse essere equipaggiata con queste uscite, la soluzione raccomandabile é di inserire un interruttore su un cavo positivo e connettersi all'amplificatore.

IMPIEGARE LA RETE DI SELEZIONE DEGLI INGRESSI

La rete di selezione degli ingressi permette al segnale RCA di essere diretto alle uscite in molti modi distinti. **La posizione di entrambi i selettori stabilisce la configurazione adottata.** I selettori possono essere configurati nei modi seguenti:

Configurazione #1

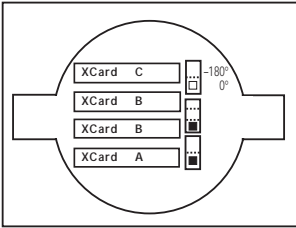

Ingresso **A** => Uscita **A**
Ingresso **B** => Uscita **B**
Ingressi **A e B** sommati => Uscita **C**

Configurazione #2

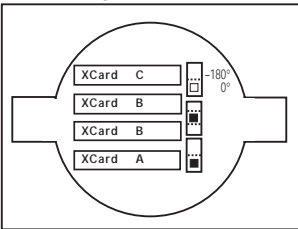

Ingresso **A** => Uscita **A**
Ingresso **B** => Uscita **B**
Ingresso **C** => Uscita **C**

Configurazione #3 (E-Z bridge Uscita C)

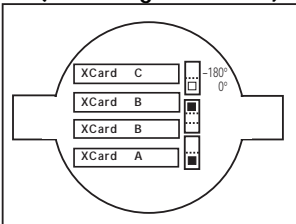

Ingresso **A** => Uscita **A**
Ingresso **B** => Uscita **B**
Ingresso **C (L mono)** => Uscita **C**

Configurazione #4

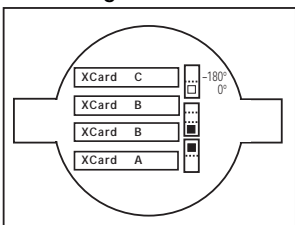

Ingresso **A** => Uscita **A, B, C**

Configurazione #5

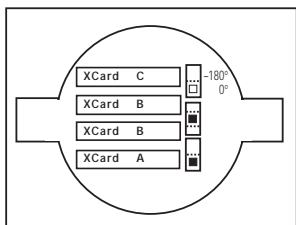

Ingresso **A** => Uscita **A, B**

Ingresso **C** => Uscita **C**

Configurazione #6

(E-Z bridge Uscita C)

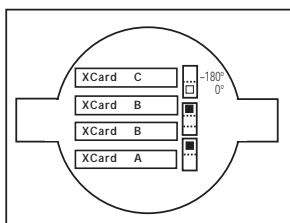

Ingresso **A** => Uscita **A, B**

Ingresso **C** (L mono) => Uscita **C**

Funzionamento a 3 canali

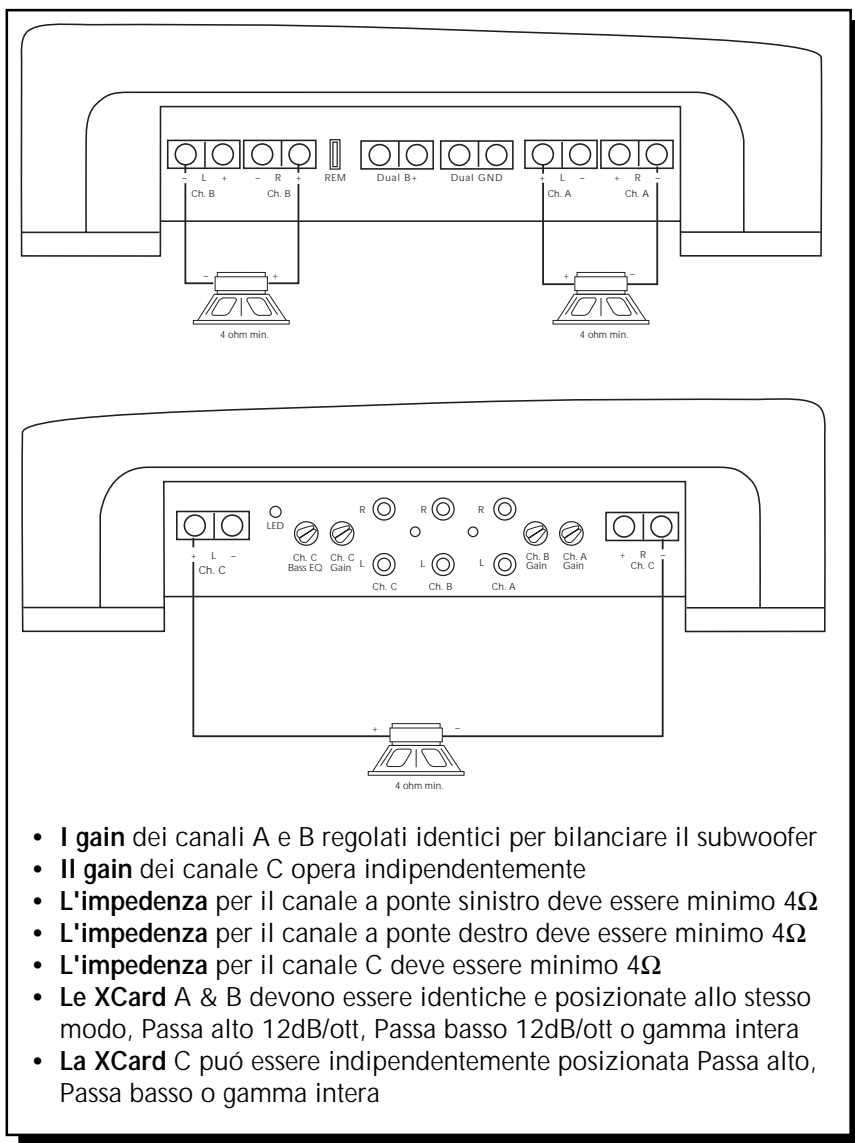

- I **gain** dei canali A e B regolati identici per bilanciare il subwoofer
- Il **gain** dei canale C opera indipendentemente
- L'**impedenza** per il canale a ponte sinistro deve essere minimo 4Ω
- L'**impedenza** per il canale a ponte destro deve essere minimo 4Ω
- L'**impedenza** per il canale C deve essere minimo 4Ω
- Le **XCard** A & B devono essere identiche e posizionate allo stesso modo, Passa alto 12dB/ott, Passa basso 12dB/ott o gamma intera
- La **XCard** C puó essere indipendentemente posizionata Passa alto, Passa basso o gamma intera

Funzionamento a 6 canali stereo

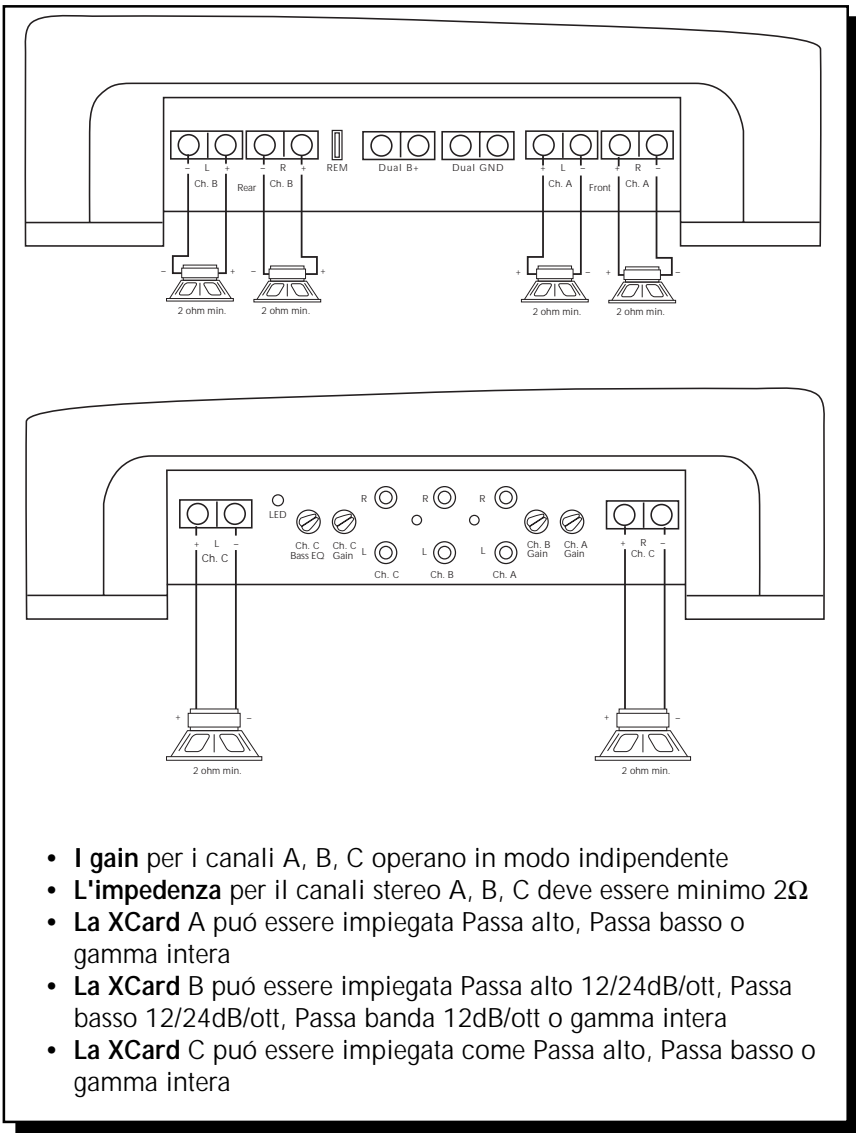

- I **gain** per i canali A, B, C operano in modo indipendente
- L'**impedenza** per il canali stereo A, B, C deve essere minimo 2Ω
- La **XCard A** può essere impiegata Passa alto, Passa basso o gamma intera
- La **XCard B** può essere impiegata Passa alto 12/24dB/ott, Passa basso 12/24dB/ott, Passa banda 12dB/ott o gamma intera
- La **XCard C** può essere impiegata come Passa alto, Passa basso o gamma intera

NOTES

NOTES

MADE IN THE USA

This product is designed, developed and assembled in the USA by a dedicated group of American workers. The majority of the components used in the construction of this product are produced by American companies. However, due to the global nature of their manufacturing facilities and the loudspeaker parts industry in general, some parts may be manufactured in other countries.

Rockford Fosgate

Rockford Corporation
546 South Rockford Drive
Tempe, Arizona 85281 U.S.A.
In U.S.A., (602) 967-3565
In Europe, Fax (49) 4207-801250
In Japan, Fax (81) 559-79-1265