

**DSM**  
**4-CHANNEL AMPLIFIER**  
**OWNER'S MANUAL**



Dear Customer,

Congratulations on your purchase of the world's finest brand of car audio amplifiers. At Rockford Fosgate we are committed to musical reproduction at its best, and we are pleased you chose our product. Through years of engineering expertise, hand craftsmanship and critical testing procedures, we have created a wide range of products that reproduce music with all the clarity and richness you deserve.

For maximum performance we recommend you have your new Rockford Fosgate product installed by an Authorized Rockford Fosgate Dealer, as we provide specialized training through Rockford Technical Training Institute (RTTI). Please read your warranty and retain your receipt and original carton for possible future use.

To add the finishing touch to your new Rockford Fosgate image, order your Rockford accessories, which include everything from T-shirts and jackets to hats and sunglasses.

To get a free brochure on Rockford Fosgate products and Rockford accessories, please call 602-967-3565 or FAX 602-967-8132. For Canada, call Korbon Trading at 416-567-1920. For International orders, FAX +001-1-602-967-8132 or call +001-1-602-967-3565.

### **PRACTICE SAFE SOUND™**

**CONTINUOUS EXPOSURE TO SOUND PRESSURE LEVELS OVER 100dB MAY CAUSE PERMANENT HEARING LOSS. HIGH POWERED AUTOSOUND SYSTEMS MAY PRODUCE SOUND PRESSURE LEVELS WELL OVER 130dB. USE COMMON SENSE AND PRACTICE SAFE SOUND.**

The serial number can be found on the outside of the box. Please record it in the space provided below as your permanent record. This will become useful in recovering your amplifier if it is ever stolen and serve as verification of your factory warranty.

Serial Number: \_\_\_\_\_

Model Number: \_\_\_\_\_

# TABLE OF CONTENTS

Specifications .....	1
Punch 4-Channel Accessory Pack .....	3
Introduction .....	4
Features and Benefits .....	4
Controls and Features .....	5
Top View of Amplifier and End Caps .....	5
Power/REM/LED Side .....	6
Input/Output Terminal Side .....	7
Installation Considerations .....	8
Tools Needed .....	9
Battery and Charging .....	9
Mounting and Location .....	10
Trunk Mounting .....	10
Passenger Compartment Mounting .....	10
Wiring the Punch .....	10
Preparing Wires and Fuses .....	10
Wiring the Fuse Holder .....	10
Wiring the Ring and Spade Connectors .....	12
Power .....	12
Ground .....	13
Remote Turn-on .....	13
Input .....	13
Speakers .....	14
Bridged/Mono Configuration .....	14
Passive Crossover Impedance .....	14
Table of Component Values .....	16
Active Crossover Mode Selection .....	17
Crossover Frequency Settings .....	17
Wiring Diagrams .....	18
Troubleshooting .....	25
Dynamic Power Measurements .....	28
Warranty Information .....	31

# SPECIFICATIONS

	PUNCH 4040DSM	PUNCH 4080DSM
Dynamic Power Rating (IHF-202 Standard) - Measured at 14.4 Volts <sup>1</sup>		
Bridged into a 4 $\Omega$ Load	115 Watts X 2	220 Watts x 2
Per channel into a 2 $\Omega$ Load	55 Watts X 4	100 Watts x 4
Per channel into a 4 $\Omega$ Load	35 Watts X 4	60 Watts x 4
Continuous Power Rating (IASCA Standard)		
RMS continuous power <b>per channel</b> , all channels driven into a 4 $\Omega$ load from 20 to 20,000 Hz, with less than 0.05% Total Harmonic Distortion (THD)	20 Watts (@ 12.6 battery volts)	40 Watts (@ 13.8 battery volts)
RMS continuous power <b>per channel</b> , all channels driven into a 2 $\Omega$ load from 20 to 20,000 Hz, with less than 0.1% Total Harmonic Distortion (THD)	40 Watts (@ 12.6 battery volts)	80 Watts (@ 13.8 battery volts)
RMS continuous power bridged into a 4 $\Omega$ load from 20 to 20,000 Hz, with less than 0.1% Total Harmonic Distortion (THD)	80 Watts (@ 12.6 battery volts)	160 Watts (@ 13.8 battery volts)
Signal-to-Noise Ratio	Over 100dB A-weighted	
Factory Default Crossover Point	100 Hz - Selectable with optional Module Cards	
Crossover Alignment	Butterworth	

<sup>1</sup>See Appendix A - Dynamic Power Measurements for information on these specifications.

**PUNCH 4040DSM****PUNCH 4080DSM**

Dimensions

9-5/8" (24.4cm) W  
 12-5/8" (32.0cm) L  
 2-5/8" ( 6.6cm) H

9-5/8" (24.4cm) W  
 13-5/8" (34.6cm) L  
 2-5/8" ( 6.6cm) H

Bandwidth

15Hz to 100kHz

Damping Factor @ 4Ω

At output connector - Over 150

Frequency Response

20Hz to 20kHz ±1dB / 10Hz to 100kHz -3dB

Crossover

12dB/octave with selectable high pass, low pass and full range  
 via interchangeable Module Cards

Slew Factor

Over 5

IM Distortion (IHF)

Less than 0.05%

Input Gain

Variable from 40dB to 14dB (200mV - 2 Volt)

The above figures are factory preset and are correct  
 for 500 mV rated source units.

Protection

Internal analog-computer output protection circuitry limits power in case of  
 overload. Thermal switch shuts down the amplifier in case of overheating.

B+ Fuse Size  
 (External to Amplifier)  
 Fuse Type

30 Amps

50 Amps

ATC

AGU

Equalization

Bass: +18dB Maximum at 45Hz

Treble: +12dB Maximum at 20kHz

Input Impedance

20k ohms

Specifications subject to change without notice.

# PUNCH 4-CHANNEL ACCESSORY PACK

---

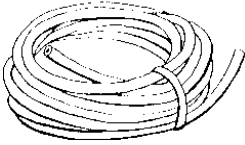

17' (518cm)  
Red Power  
Wire

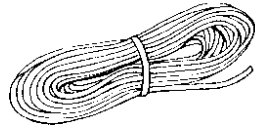

12' (366cm)  
Blue Remote  
Turn-on Wire

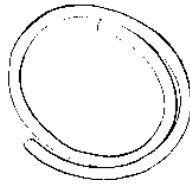

1.5' (46cm) Black  
Grounding Wire

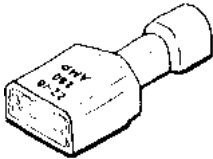

Remote Turn-on Wire  
Connector Plug



Power Ring  
Terminals



Allen Head Set Screws  
and Mounting Screws

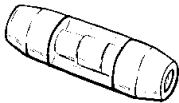

Fuse Holder 4080

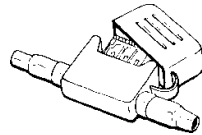

Fuse Holder 4040

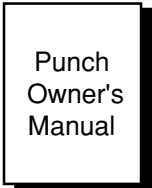

# INTRODUCTION

---

## Features and Benefits

This manual provides information on the features, installation, and operation of the Punch 4040 DSM and 4080 DSM Amplifiers. We suggest you save this manual for future reference.

We strongly recommend you have your Authorized Rockford Fosgate Dealer install your new Punch 4-channel amplifier. If you do choose to install the amplifier yourself, please be sure to read the entire manual before beginning.

The Rockford Fosgate 4-Channel automotive stereo power amplifiers provide state-of-the-art sound in cars, vans, boats, or wherever a high current 12 volt power source is available.

**“Discrete Surface Mount” (DSM)** technology is utilized in the crafting of all of our Punch amplifiers. This process provides greater ruggedness and consistency of both components and layout. Already used heavily in aerospace and industrial applications, this technology is also highly advantageous in the hostile automotive environment.

**Low Level Input Sensitivity.** The Punch 4-channel adjustable input circuits are designed to match almost any music source. The amplifiers will drive most normal speaker types.

**Punch Equalization.** This circuit is designed to compensate for the acoustic inadequacies of the automotive environment. This patented circuitry will correct for the poor bass response and natural high frequency roll-off inherent in the world of automotive stereo. The result is full-range sound without the unpleasant changes in the mid-range sound produced by most tone control and equalizer circuits.

**Active Electronic Crossover Modules** built-into the 4040 and 4080 features 12 dB/octave Butterworth filters. The independent crossover points in these plug-in modules allow for various configuration possibilities.

**Real Time Power Protection (R.T.P.P.)** allows for the greatest power output under all load conditions. When output reaches an unsafe level it will be reduced, unlike current limiting which often causes premature protection or failure to protect at all.

To get a better understanding of the Punch let's take a closer look.

## CONTROLS AND FEATURES

---

This section describes the various controls and features of the Punch 4040 DSM and 4080 DSM amplifiers.

### Top View of Amplifier and End Caps



#### **Punch 4-Channel Housing**

The cast aluminum heatsink of the Punch 4-Channel is designed for high performance cooling. The raised design of the housing allows cables and wires to run underneath the unit. This provides for greater wiring flexibility and protects the cables from damage caused by excessive heat and bending.

#### **End Caps**

Interchangeable end caps conceal the wiring and input cables, giving the amplifier a clean, "stealth" look. Also incorporated, is a holding dimple built into the end cap. This small feature enables the cap to be held in place while being mounted.

The end caps are secured to the housing with flush mounting, captive screws.



**Mounting  
Screws**

Four (4) custom, round, hex screws included in the accessory pack hold the unit in place. These screws are covered when the end caps are installed.

**Power/REM/LED Side**

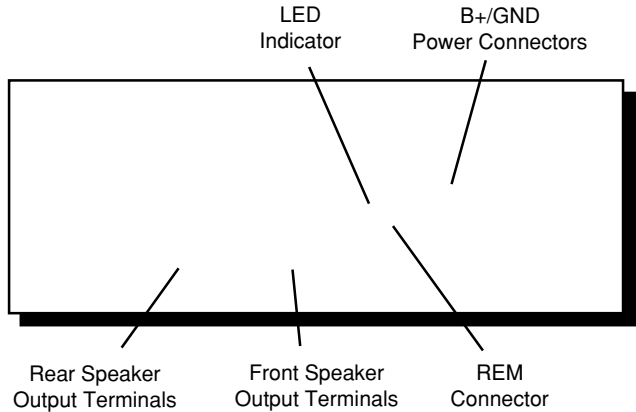

**REM  
Connector**

The Punch 4-Channel is turned on by connecting the blue remote turn-on wire to the source unit's "Accessory" or "Auto Antenna" lead, either of which will go to +12 volts when the source unit is turned on.

**LED Power  
Indicator**

The LED illuminates when the unit is activated.

**B+/GND  
Power  
Connector**

These connectors are used to supply power and ground to the amplifier and accept 12 gauge - 8 gauge wire.\*

**Speaker  
Output  
Terminals**

These gold-plated terminal blocks connect the Right/Left Front and Right/Left Rear channel outputs to the speakers and accept wire sizes from 8 gauge through 18 gauge. Gold-plated connectors are immune to corrosion that can cause signal deterioration.

\*Rockford Fosgate's Perfect Interface line of accessories includes high quality power and speaker wire, gold plated RCA interconnecting cable and other products to complete your installation. Ask your Authorized Rockford Fosgate Dealer about Perfect Interface.

## Input/Output Terminal Side

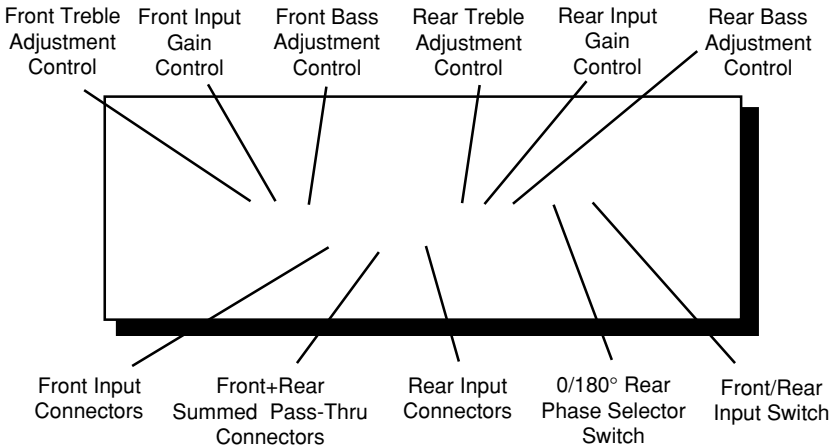

### Front/Rear Input Switch

This switch allows you to use the front input to drive both Front and Rear channels. Switching to Rear position allows you to run separate Front and Rear inputs. This eliminates the need for a "Y-adapter" when using the amplifier in a bi-amplified or 4-Channel mode.

### 0/180° Rear Phase Selector Switch

This switch enables you to easily invert the phase of the Rear channels on the amplifier without having to disconnect the speaker wires. See the wiring diagram on page 17 for use.

### Treble/Bass

These controls adjust the amount of treble and bass response desired. To increase the amount of response, turn the controls clockwise; to decrease, turn the controls counterclockwise. Note that there are separate Bass and Treble controls for Front and Rear channels.

### Input Gain Controls

These controls are factory preset to 500 millivolts to match most head units and are variable from 100 millivolts to two volts. (***More than likely they will not need adjusting.***)

If just a little volume from the source unit drives the amplifier into distortion, reduce the input gain controls so that the distortion doesn't start until the source volume is at about 3/4 of its rotation. Note that there are separate Front and Rear gain controls.

<b>Input Connectors</b>	The amplifier's signal input, female, RCA jacks should be connected to the source unit's signal outputs with high-quality RCA cables. The connectors have been plated in gold to eliminate the possibility of corrosion that can cause signal deterioration.
<b>Front &amp; Rear Summed Pass-Thru Connectors</b>	<p>These pass-thru connectors allow you to daisy-chain an additional Punch amplifier without running an additional set of RCA cables from the front of the vehicle to the rear amplifier location. The crossover module in the Pass-Thru RCA circuit allows the daisy-chained amplifier to be configured independently of the Front and Rear channels for low pass, high pass or full range operation.</p> <p>The Pass-Thru signal is derived by summing the Front Left and Rear Left inputs to create the Left output, and summing the Front Right and Rear Right input to create the Right output. This provides constant output regardless of the source unit fade position.</p>

## **INSTALLATION CONSIDERATIONS**

---

This section focuses on some of the vehicle considerations for installing your new Punch 4-Channel amplifier. Checking your battery and current sound system, as well as pre-planning your system layout and best wiring routes will save installation time. When deciding how to lay out your new system, be sure that each component will be easily accessible for making adjustments.

Before beginning any installation, be sure to follow these simple rules:

1. Carefully read and understand the instructions before attempting to install the amplifier.
2. For easier assembly, we suggest you run all wires prior to mounting your amplifier in place.
3. Use only quality connectors for making connections. See your Authorized Rockford Fosgate Dealer for Perfect Interface wire enhancements.

4. **Think before you drill!** Be careful not to cut or drill into gas tanks, fuel lines, brake or hydraulic lines, vacuum lines or electrical wiring when working on any vehicle.
5. **For safety**, disconnect the battery ground cable prior to beginning the installation process.
6. Never run wires underneath the vehicle. The cleanest, safest wiring connections are made by running the wire under the carpet or behind the side panels. Never leave wires exposed.
7. Avoid running wires over or through sharp edges. Use grommets to protect wires routed through holes in metal.
8. **ALWAYS** protect the battery and electrical system from shorts with proper fusing. A fuse holder and fuse must be installed within 18" (46cm) of the battery terminal to safeguard from possible damage or injury.
9. Grounding connections should be as short as possible and always be connected to metal that is welded to the main body, or chassis, of the vehicle.

**Tools  
Needed**

The following is a list of tools you will need for installing the Punch amplifier:

7/64" & 3/32" Allen Wrenches (included)	
Wire Strippers	Wire Cutters
Battery Post Wrench	Voltmeter
Electric Hand Drill with assorted bits	Wire Crimpers

## **BATTERY AND CHARGING**

---

Punch amplifiers will naturally put an extra load on your battery and charging system. We recommend you check your alternator capacity to ensure ample charging capability to handle the additional load of your new Punch equipment. Stock electrical systems in good condition should typically handle the extra load of any individual Punch unit without problems. If problems arise, we suggest you first check the charging system, then use a heavy duty battery and/or a high output alternator as needed.

## MOUNTING AND LOCATION

---

	<p>The mounting location and position of the Punch 4-Channel will have a great effect on its ability to dissipate the heat generated in normal operation. The Punch 4-Channel has a heatsink designed for heat dissipation and internal shutoff circuitry to avoid overheating. It is reasonably tolerant of mounting variations. However, care should be taken to ensure adequate ventilation.</p>
<b>Trunk Mounting</b>	<p>The temperature inside a trunk can reach as high as 175° F (80° C) during the summer months. Since the thermal shutoff point for the Punch 4-Channel is 195° F (90° C), it is easy to see that the amp must be mounted for maximum cooling capability. Mounting the amplifier on the floor or under the rear parcel tray prevents sufficient convectional air flow cooling. Mounting the unit vertically on a surface with the fin grooves running up and down usually results in the best cooling.</p>
<b>Passenger Compartment Mounting</b>	<p>Under the seat or floor mounting will work as long as there is a minimum of 1" (2.5cm) of air gap above the amplifier's heatsink.</p> <p>Vertical mounting of the amplifier is still the best.</p>

## WIRING THE PUNCH

---

	<p><b>Caution! Be sure to avoid running the power wires near the low level input cables, antenna, power leads, sensitive equipment or harnesses. The power wires carry substantial currents and could induce noise.</b></p>
<b>Preparing Wires and Fuses</b>	<p>The following instructions explain how to prepare the wires, connectors and fusing. We suggest you perform these procedures prior to wiring and mounting your new Punch 4-Channel amplifier.</p>
<b>Wiring the Fuse Holder</b>	<ol style="list-style-type: none"><li>1. Use approximately 18" (46cm) of the <i>red</i> power wire. Strip one end of the wire back 1/2" (1.3cm) as shown in the following diagram:</li></ol>

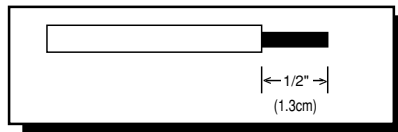

2. For the Punch 4040, place the protective boot onto the wire. Insert the wire into one end of the fuse holder so that the insulation is just inside the crimp area as shown in the diagram. Crimp the wire in place with the notched portion of a crimping tool. Cover the crimped area with the protective boot that is supplied with the fuse holder.

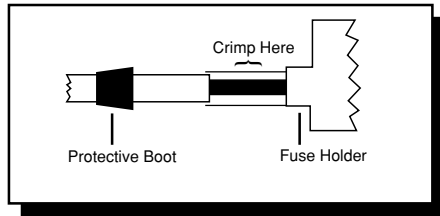

3. For the Punch 4080, place the protective boot onto the wire. Slide the wire into the wire sleeve. Making sure the screw holes on the wire sleeve and fuse holder align, insert the prepared wire sleeve into the smaller end of the fuse connector. Tighten the wire in place with the enclosed allen screw. Screw the protective boot onto the fuse holder.

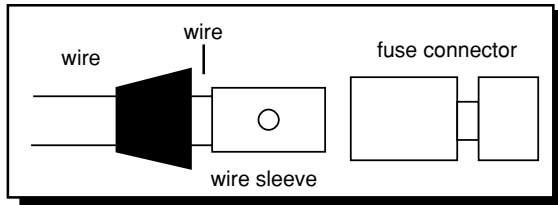

4. Repeat the above steps to connect the remainder of the red power wire to the other side of the fuse holder and route to the amplifier mounting location.

## Wiring the Ring and Spade Connectors

1. Strip back approximately 3/8" (1cm) of insulation.

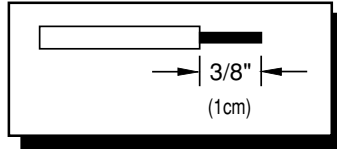

2. Insert the bare wire into the connector and crimp in place as shown in the following diagram:

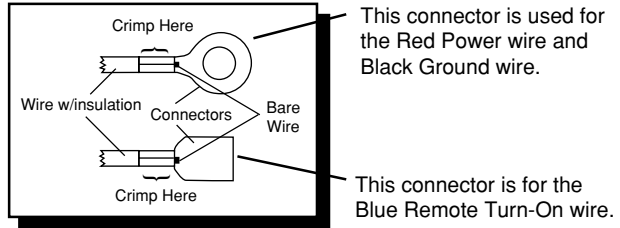

## Power

The gold **B+** terminal on the amplifier must be connected *directly* to the positive (+) terminal of the battery with an appropriate size fuse. (See the Specifications Table for more information.) This provides a power source with a low voltage drop and low noise. **Be sure to use the supplied fuse and fuse holder within 18" (46cm) of the battery's positive terminal. Failure to do so may cause damage to the vehicle and the amplifier.**

If the power wire must be extended beyond 17' (518cm), we recommend you use 8 gauge, or heavier, stranded wire.

## Using Larger Gauge Wire

If using a larger gauge wire than that supplied with your new Punch 4-Channel, cut the wire casing on the diagonal as shown in the following diagram. Insert the wire into the connector. Twist the wire around so that the long end of the insulation faces up. Bend the wire prior to tightening in place. This will make it easier for attaching the end cap to the amplifier.

**Note: For easier assembly, only 5/8" (1.6cm) of wire should be bare.**

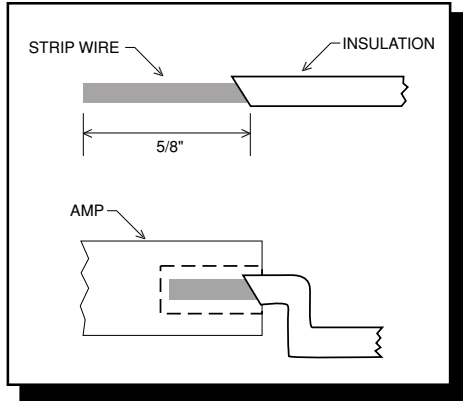

**Ground**

The **GND** terminal grounds the amplifier and is connected to the chassis of the vehicle with 12 gauge, or heavier, stranded wire. When grounding, scrape paint off metal to ensure a good, clean ground connection. To prevent ground loops, we recommend you refrain from extending the ground wire beyond 18" (46cm) in any installation.

**Remote Turn-on**

The Punch 4-Channel amplifiers are turned on by supplying positive (+) 12 volts to the **REM** terminal. Usually the terminal is connected to the source unit's "Accessory" or "Auto Antenna" lead, either of which will go to +12 Volts when the source unit is turned on.

Although the majority of high-quality automotive source units have an Accessory or Antenna output, there are many which require different turn-on methods. If the source unit has no Auto Antenna lead (or if the Auto Antenna goes down during tape operation), we recommend a switch in the car with one terminal connected to +12 volts and the other to the Punch 4-Channel REM lead. This will allow you to engage the amplifier manually.

**Input**

The amplifier's signal input RCA jacks should be connected to the source unit's signal outputs with high-quality braided or double-shielded interconnecting RCA cables.

**Note: Be sure to route the Punch 4-Channel signal input cable away from the main power wire and the car's wiring harnesses to avoid noise coupling.**



<b>Speakers</b>	<p>Punch 4-Channel amplifiers are rated for safe operation into loads of <math>2\Omega</math>, or greater in stereo mode or <math>4\Omega</math> in bridged/mono configurations. The primary loads on any amplifier come from directly connected speakers without using capacitors. The measured resistance for each side should not be less than <math>2\Omega</math> stereo or <math>4\Omega</math> bridged/mono.</p>
<b>Bridged/Mono Configuration</b>	<p>The Punch 4-Channel amplifiers are capable of bridged/mono configurations.</p> <p>This configuration enables you to:</p> <ul style="list-style-type: none"> <li>• Run amplifier as a separate 2 channel subwoofer or satellite amplifier.</li> <li>• Create a high power stereo system</li> <li>• Run 2 channels with a bridged mono woofer and the other 2 as a high-frequency stereo amp, etc.</li> </ul> <p><b>Note: Both Punch 4-Channel amplifiers allow the above 3 configurations all in one.</b></p> <p>For more information refer to the wiring diagrams beginning on page 18.</p> <p><b>Note: To bridge the amplifier use the L+ and R– speaker connectors.</b></p> <p><b>Caution! Punch 4-Channel amplifiers are not recommended for impedance loads below <math>2\Omega</math> stereo or <math>4\Omega</math> bridged/mono.</b></p> <p><b>Be sure to observe proper speaker terminal polarity throughout the system. It is critical for the Punch 4-Channel to use the correct negative terminals for right and left channels, since the RIGHT NEGATIVE (–) terminal is the “hot” terminal for the right speaker. DO NOT chassis ground any of the speaker leads as unstable operation may result.</b></p>
<b>Passive Crossover Impedance</b>	<p>A passive crossover is a circuit that employs capacitors and/or coils and is placed on speaker leads between the amplifier and speaker to delegate frequencies in the speaker’s optimum performance range.</p>

The most commonly used filter networks are 6 dB per octave systems. These are easy to construct and require a minimum number of parts. A filter network can perform one of three functions. These are highpass (capacitors), lowpass (inductors, chokes or coils) and bandpass (combination of a capacitor and a coil).

The result, limiting the types of frequency to the speaker, is directly dependent upon the speaker's impedance and component values.

The most common filters used in speaker crossovers, as stated above, are 6 dB per octave which use one component per filter. Placing this filter in series with the circuit will reduce power to the speaker by 6 dB per octave above or below the crossover point depending on whether it is a High Pass or Low Pass filter. When passive crossover components are used in multiple speaker systems, the crossover system's effect on the overall impedance should be taken into consideration along with the speaker's impedance when determining amplifier loads.

More complex systems such as 12 dB or 18 dB per octave can cause impedance problems if not professionally designed. If such a system is required, we recommend consulting an Authorized Rockford Fosgate Dealer.

## Table of Component Values

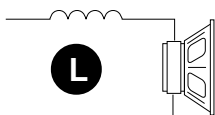

**6 dB/Octave Low Pass**

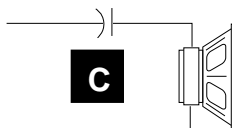

**6 dB/Octave High Pass**

Freq. Hertz	Speaker Impedance					
	2 OHMS		4 OHMS		8 OHMS	
	<b>L</b>	<b>C</b>	<b>L</b>	<b>C</b>	<b>L</b>	<b>C</b>
80	4.1mH	1000 $\mu$ F	8.2mH	500 $\mu$ F	16mH	250 $\mu$ F
100	3.1mH	800 $\mu$ F	6.2mH	400 $\mu$ F	12mH	200 $\mu$ F
130	2.4mH	600 $\mu$ F	4.7mH	300 $\mu$ F	10mH	150 $\mu$ F
200	1.6mH	400 $\mu$ F	3.3mH	200 $\mu$ F	6.8mH	100 $\mu$ F
260	1.2mH	300 $\mu$ F	2.4mH	150 $\mu$ F	4.7mH	75 $\mu$ F
400	.8mH	200 $\mu$ F	1.6mH	100 $\mu$ F	3.3mH	50 $\mu$ F
600	.5mH	136 $\mu$ F	1.0mH	68 $\mu$ F	2.0mH	33 $\mu$ F
800	.41mH	100 $\mu$ F	.82mH	50 $\mu$ F	1.6mH	26 $\mu$ F
1000	.31mH	78 $\mu$ F	.62mH	39 $\mu$ F	1.2mH	20 $\mu$ F
1200	.25mH	66 $\mu$ F	.51mH	33 $\mu$ F	1.0mH	16 $\mu$ F
1800	.16mH	44 $\mu$ F	.33mH	22 $\mu$ F	.68mH	10 $\mu$ F
4000	.08mH	20 $\mu$ F	.16mH	10 $\mu$ F	.33mH	5 $\mu$ F
6000	51 $\mu$ H	14 $\mu$ F	.10mH	6.8 $\mu$ F	.20mH	3.3 $\mu$ F
9000	34 $\mu$ H	9.5 $\mu$ F	68 $\mu$ H	4.7 $\mu$ F	.15mH	2.2 $\mu$ F
12000	25 $\mu$ H	6.6 $\mu$ F	51 $\mu$ H	3.3 $\mu$ F	100 $\mu$ H	1.6 $\mu$ F

### 6 dB/Octave High and Low Pass Filters

L = Low Pass (Inductor)

C = High Pass (Capacitor)

For more information, see your Authorized Rockford Fosgate Dealer.

**Active  
Crossover  
Mode  
Selection**

The Punch 4-Channel amplifiers feature selectable electronic crossovers. Selection is made by positioning of a removable module card. These modules control the output channels and can be configured in a High Pass, Low Pass or Full Range (factory default) position. The 4-Channel amplifiers are shipped with 100Hz 12dB per octave Butterworth aligned crossover modules. Additional crossover frequency modules are available from your Authorized Rockford Fosgate Dealer.

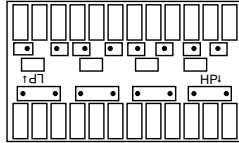

**Note: The factory default is Full Range.**

**Crossover  
Frequency  
Settings**

To change the crossover mode, remove the crossover module from the housing. Rotate the module to the desired setting and gently push the module back into the amplifier housing as shown on the diagram on the back of the amplifier.

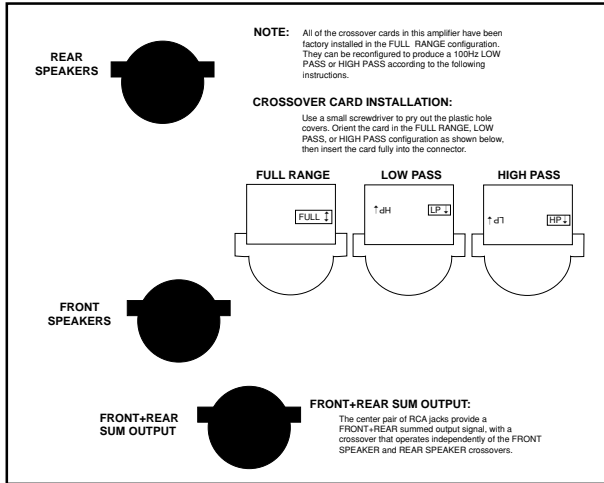

Example: The 4040 DSM is shipped with three 100 Hz modules. With the modules in the Full Range setting, the amplifier will pass through all 20Hz -20kHz frequencies.

In the Low Pass setting, only those frequencies below 100 Hz will pass through the amplifier.

In the High Pass setting, only those above 100 Hz will pass through the amplifier.

# SAMPLE WIRING DIAGRAMS

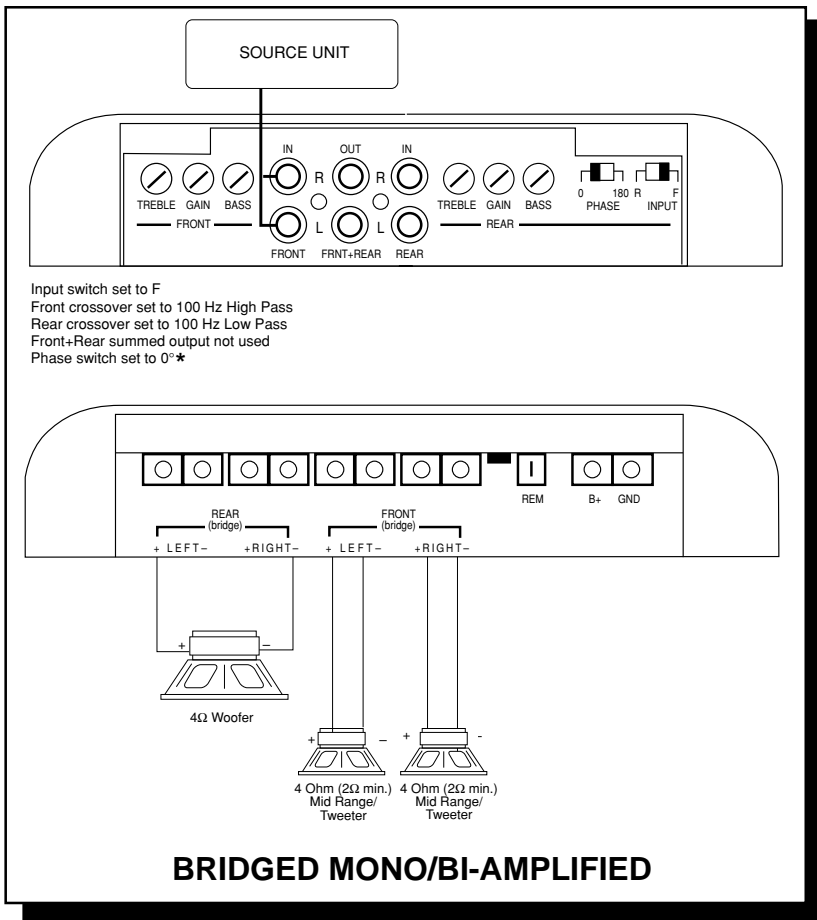

\* Always start with the phase switch on 0°, then switch to 180° and listen. Select the position that provides the best frequency response.

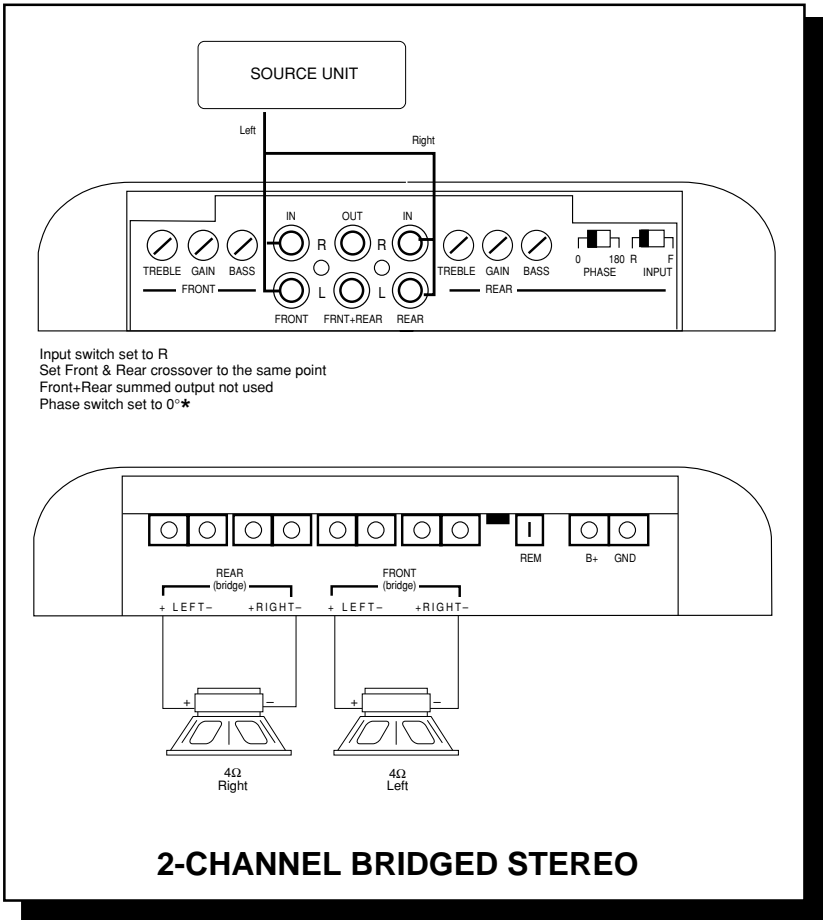

\* In this mode the phase switch should always be at 0°. Switching to the 180° position will result in an "out of phase" condition and a loss of output.

(Alternate Version: 100Hz High Pass Front & Rear -4Ω Full Range)

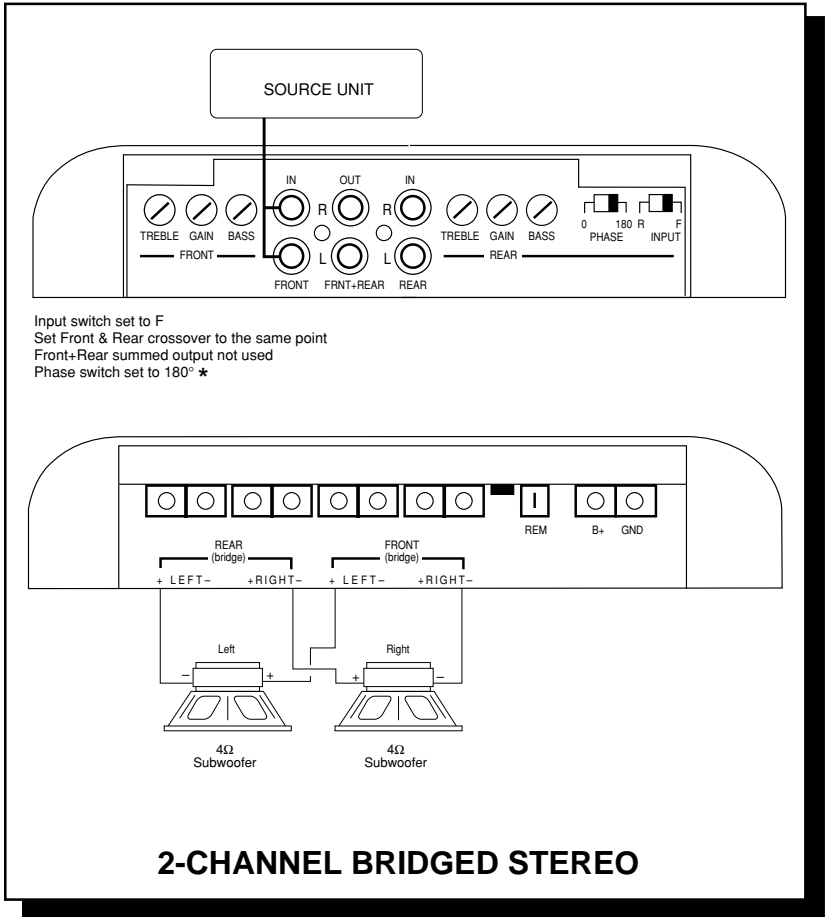

\* In this mode the phase switch should always be at 180°. Switching to the 0° position will result in an "out of phase" condition and a loss of output.

(Alternate Version: 100Hz High Pass Front & Rear -4Ω Full Range)

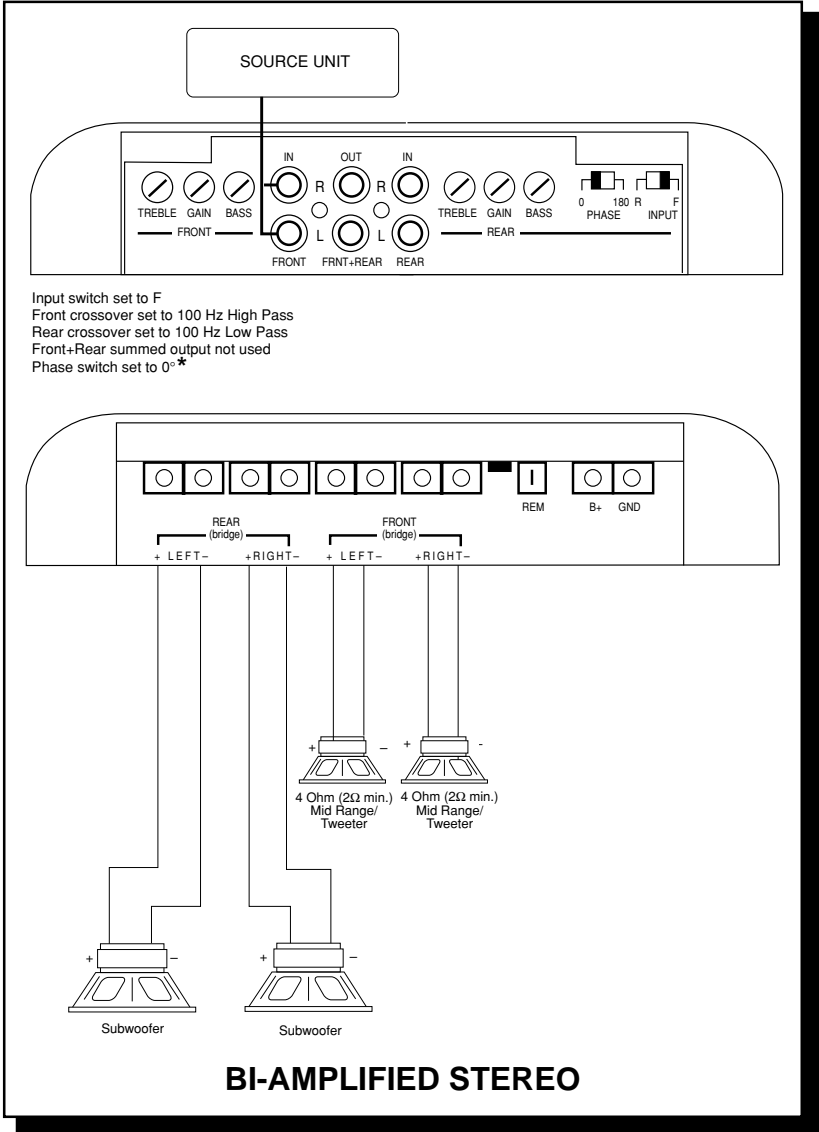

\* Always start with the phase switch on 0°, then switch to 180° and listen. Select the position that provides the best frequency response.



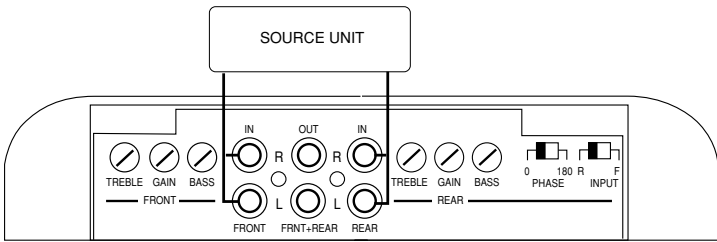

Input switch set to Rear  
 Front crossover set to Full Range  
 Rear crossover set to Full Range  
 Front+Rear summed output not used  
 Phase switch set to 0°

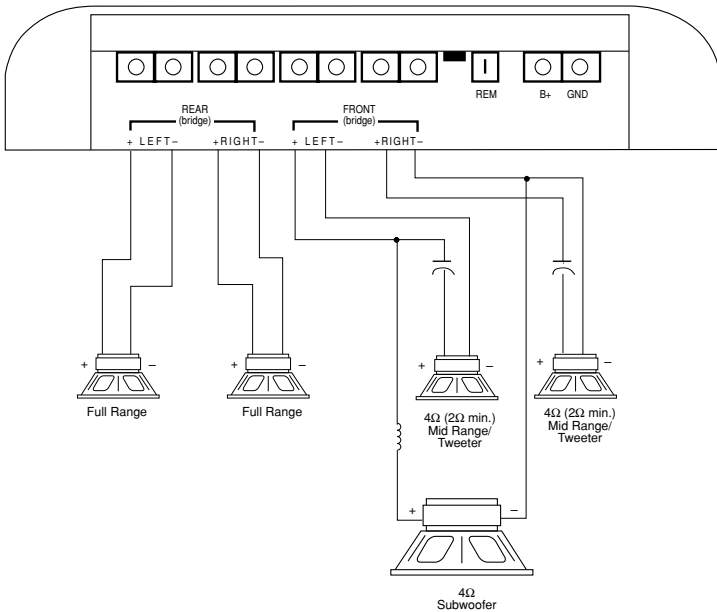

## 4-CHANNEL WITH BRIDGED SUBWOOFER

- Allows front to rear fading
- Sub-woofer is optional
- Sub-woofer can be bridged on front or rear or both

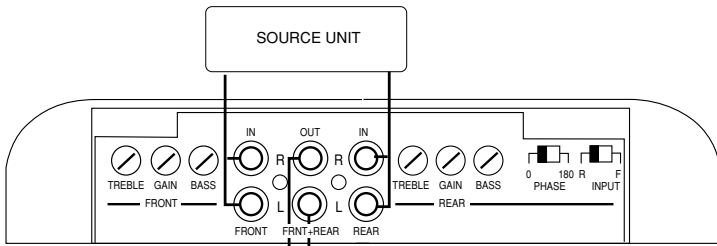

Input switch set to Rear  
 Front crossover set to Full Range  
 Rear crossover set to Full Range  
 Front+Rear crossover set to 100Hz Low Pass  
 Phase switch set to 0°

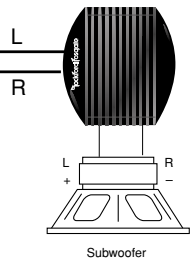
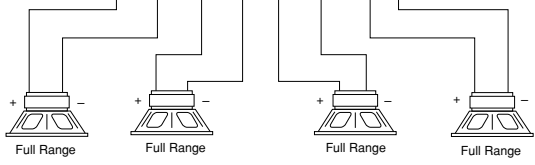
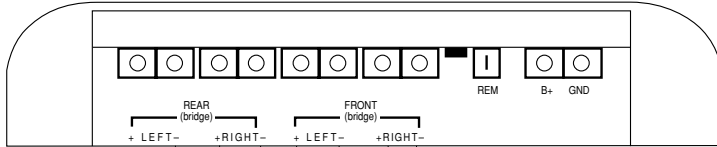

**4-CHANNEL WITH SUBWOOFER AMP**

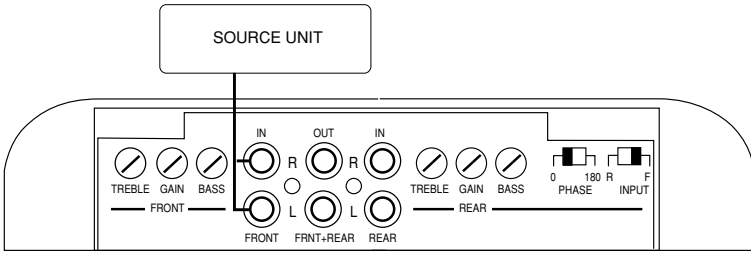

Input switch set to F  
 Set Front & Rear crossovers to the same point  
 Front+Rear summed output not used  
 Phase switch set to 0° \*

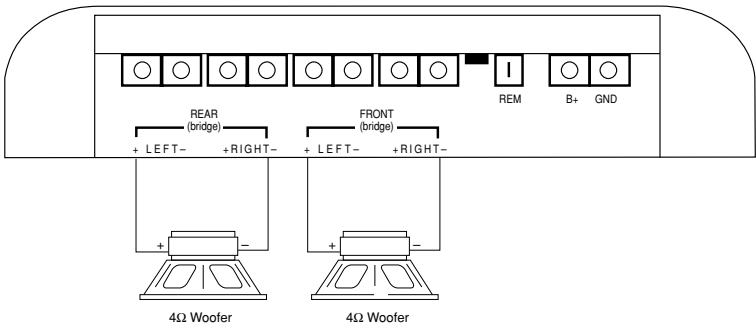

## BRIDGED MONO

# TROUBLESHOOTING

---

**Problem**

Amplifier will not play – Remote turn-on light is off.

**Solution**

1. Check the DC voltage at the amplifier's B+ terminal with a voltmeter. The voltage should measure between 11.5V - 15.5V.

If voltage is not found, check the battery, fuse, fuse housing and wire connections. Fix, repair, or replace accordingly.

2. If the amplifier still does not play, check the voltage at the amplifier's remote turn-on lead. The voltage should measure between 11V - 15V.

a. If voltage is above or below the prescribed measurements, have the head unit checked by an Authorized Dealer or Service Center.

b. If the remote turn-on current draw from the head unit is connected to multiple amps and/or electronics, the current draw may be too great. Check for proper connections. (Use a relay to suppress the excessive current draw.)

If you are still having problems, have the amplifier checked by an Authorized Rockford Fosgate Dealer.

**Problem**

Amplifier will not play – Remote turn-on light is on:

**Solution**

1. Unplug the head unit and test the amplifier with another working source unit (i.e., bench-test radio, walkman, etc.) If the amplifier plays, check the in-dash leads for cuts, breaks and/or shorts.

2. If the amplifier still does not play, disconnect the existing speakers and connect a set of test speakers to the output of the amplifier (any type of speaker will do - i.e., simple home box type, bookshelf, raw speaker, etc.). If the amp plays, check for shorts or blown voice coils in the vehicle's speaker system.

If you are still having problems, have the amplifier checked out by an Authorized Rockford Fosgate Dealer.

**Problem**

Amplifier gets too hot.

**Solution**

1. Be sure the amplifier is properly mounted. You should be able to place your hand a few inches above the amplifier housing and feel the heat rising when the unit is on.

Hot air rises, consequently, mount the amplifier with the heatsink fins aligned vertically. This allows the air to flow freely, carrying away the heat. Check to see that the heatsink fins are free of any obstruction (i.e., carpet, seats, etc.).

2. If #1 does not solve the problem, check to see that the impedance of the overall system is not less than  $2\Omega$  as described on page 14. Using an AC impedance meter (Perfect Interface IM-1), sweep from 20 Hz - 20 kHz, and look for dips below the  $2\Omega$  rating.

Be sure to test the bass region (20 Hz - 150 Hz) of your system. If the amplifier is bridged to those speakers, the load the amp sees is one-half (1/2) of the reading on the AC impedance meter.

If the impedance level is below  $2\Omega$ , check for bad speakers and/or crossovers, proper use of passive crossovers, or try rewiring the entire system.

**Problem**

Amplifier Noise (Turn-On Pop)

**Solution**

1. Disconnect the RCA plugs from the amplifier and recheck the amp by turning the unit on and off. If turn-on pop goes away, connect a delay turn-on module (Perfect Interface DT-1) to the amplifier. (See your Authorized Rockford Fosgate Dealer for more information.)
2. If the noise persists, disconnect the turn-on wire from the head unit and use a different +12 volt power source to turn on the amplifier (i.e., battery direct). If the noise is gone, use a relay to switch +12 volts auto power from the clean power source.

**Problem**

Engine Noise (Whine)

**Solution**

1. Disconnect the speakers from the amplifier. Connect a test speaker to the amplifier output terminals. If the noise goes away, check your speaker leads, speakers and crossovers.
2. If the noise persists, use a "shorting plug" to mute the input signal at the amplifier. If the noise goes away:
  - a. Bypass all of the other equipment (i.e., crossovers and equalizers) and connect the head unit directly to the amp. If the noise disappears, reconnect the equipment, being sure to test for noise after each install. Logic indicates that the last unit installed is the culprit. Refer to the unit's owner's manual for more information.
  - b. If the noise persists, connect a new RCA line from the head unit to the amplifier. If there is no noise, replace the RCA cable.
  - c. If the noise is still present after replacing the RCA cable, run the RCA cable on a different route.
  - d. Isolate the grounds in your head unit so there is only one grounding point. If the noise disappears, install the radio, using only one (1) grounding point. Isolate the radio chassis from the grounding on the dash, and use an antenna grounding loop isolator on the antenna.

If noise still persists, see your Authorized Rockford Fosgate Dealer.

# DYNAMIC POWER MEASUREMENTS

---

## About the Dynamic Power Measurements

The *Audio Graph PowerCube* is a test instrument used to measure the output of an amplifier in accordance with IHF-202 industry standards. The IHF-202 standard is a Dynamic power measurement and was developed as a means of measuring power in a manner that best represents the Real World operation of an amplifier. Many manufacturers, including Rockford Fosgate, at times will measure amplifier power into a fixed resistor (4 ohm, 2 ohm). While this method is useful in some types of evaluation and testing, it is not representative of an amplifier that is connected up to a speaker and playing music.

## Music

Music is dynamic; the sound waves are complex and constantly changing. In order to simulate this, the IHF-202 standard calls for the input signal to the amplifier to be a 1kHz bursted tone. This signal is input (on) for a short period of time and then off for a “rested” period. The signal is gradually increased in level until the amplifier’s output exceeds 1% Total Harmonic Distortion (THD). At 1% distortion becomes audible, therefore, any power produced above that level is considered *unusable*. Many manufacturers represent their amplifiers’ output power in excess of 10% distortion. They use many names for this measurement, such as Total Maximum Power or Maximum Output Power. This is not indicative of the *actual usable output power*.

## Listening to Loudspeakers - Not Resistors

A loudspeaker is not a resistor. A resistor’s value (resistance measured in ohms) is fixed. A loudspeaker’s impedance is dynamic. It is constantly changing in value, dependent upon the frequency of the input signal. Therefore, measuring power with the amplifier loaded into a 4 ohm resistor is not the same as measuring power with the amplifier connected to a 4 ohm speaker. Most people do not listen to music through a resistor.

A 4 ohm speaker may experience a drop in impedance 4-6 times lower than its nominal (printed) impedance. A speaker will also create phase shifts in the signal that is passed through it. These phase shifts happen because a speaker is an inductor (voice coil) and a capacitor (compliance of the surround/spider), as well as a resistor (voice coil wire).

To simulate a speaker the *Audio Graph PowerCube* measures output power into 20 different loads. It tests at 8 ohms, 4 ohms, 2 ohms and 1 ohm. Each of these impedances is also tested at  $-60^\circ$ ,  $-30^\circ$ ,  $0^\circ$ ,  $+30^\circ$  and  $+60^\circ$  phase angles. These different impedances and phase angles represent the shifts in impedance and phase that can occur in a typical loudspeaker.

### Information Cubed

The data acquired in the testing procedure is then graphed in the form of a 3-dimensional cube, hence the name **PowerCube**.

The *Phase Angle* is expressed on the horizontal axis, the *Output Voltage* is presented on the vertical axis and the *Impedance* is displayed on the Z axis. *Output Power*, in watts, is listed on the left hand side for each impedance at each phase angle.

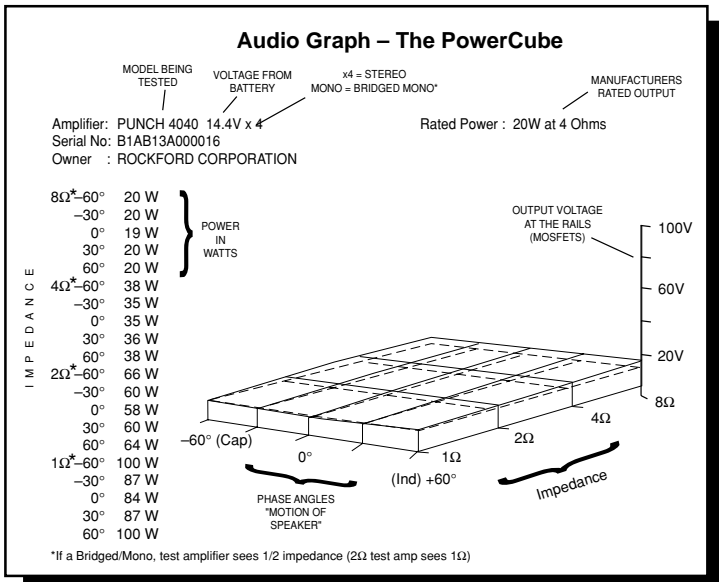



## What is an Amplifier?

An amplifier by definition is a voltage generating device, recreating the signal which is input to in an identical but *amplified* form. It will be connected to a reactive load (the speaker). The impedance of this load and phase of the signal passing through the load will vary, dependent upon the frequency and amplitude of the input signal (music).

Therefore, a perfect amplifier will be able to maintain the same output voltage regardless of load characteristics and will not alter the signal it is reproducing. A perfect amplifier when measured by the *AudioGraph PowerCube* would present data that forms a perfect cube. Unfortunately, amplifiers are not perfect. The laws of physics generally prevent it. A great amplifier is about the best one can hope for.

As you can see by the *PowerCube* and as you will experience by listening, your Punch amplifier is a GREAT AMPLIFIER!

# WARRANTY INFORMATION

---

Rockford Fosgate warrants all electronics to the original consumer/purchaser to be free from defects in materials or workmanship for a period of three (3) years. We will cover parts and labor provided the product was purchased from an Authorized Rockford Fosgate Dealer. This warranty does not apply to any product on which the seals and/or serial number have been broken, removed, tampered with, defaced or altered in any manner. This warranty applies only to the original consumer/purchaser and is not transferable.

Electronics found to be defective during the warranty period will be repaired or replaced at Rockford Fosgate's discretion. Repaired or replaced electronics will be covered by the balance of the original warranty period only. Rockford Fosgate shall not be responsible for any incidental or consequential damages resulting from a defect in electronics. Some states do not allow the exclusion or limitation of incidental or consequential damages, so the previous limitation may not be applicable.

The warranty does not cover any appearance item, any cost or expense related to the removal or reinstallation of the product, any accessory used in conjunction with the product, damage to the product resulting from alteration, accident, misuse or abuse, or improper installation. This warranty does not apply if the parts or labor, which would otherwise be provided without charge under this warranty, are obtained from any source other than Rockford Fosgate or an Authorized Rockford Fosgate Service Center.

This warranty is the only express warranty and does not create any implied warranties. Rockford Fosgate limits its obligations under any implied warranties under state laws to a period not to exceed the written warranty period. Some states do not allow limitation on how long an implied warranty lasts, so the above limitation may not apply. This warranty applies only to products sold in the United States of America or its possessions. For warranty outside the U.S.A., please contact the nearest Authorized Rockford Fosgate Dealer. This warranty gives the consumer specific legal rights, and the consumer may have other rights which vary from state to state.

A defective product must be shipped prepaid to the Authorized Rockford Fosgate Dealer from which the consumer purchased the product or to the Rockford Fosgate factory in Tempe, Arizona in the original factory carton or equivalent. Any shipping loss or damage will be borne by the consumer or the consumer's shipper. A consumer returning a product to the factory should call (800) 669-9899 for a Return Authorization Number. All shipments shall be clearly marked with the Return Authorization Number on the outside of the shipping carton.

Rockford will provide free shipping for electronics under warranty to Authorized Rockford Fosgate dealers. Prepaid, pre-addressed Federal Express airbills are available by calling Rockford Customer Service at 1-800-669-9899.

Ship to:  
Rockford Corporation  
Warranty Repair Department  
2055 E. 5th Street  
Tempe, AZ 85281 U.S.A.  
Return Authorization Number: \_\_\_\_\_

**Rockford Fosgate**

A Division of Rockford Corporation  
546 South Rockford Drive  
Tempe, Arizona 85281 U.S.A.  
In U.S.A., (602) 967-3565  
In Canada, call Korbon (416) 567-1929  
In Europe, Fax (49) 4207-801250