



**Rockwell
Collins**

Vehicle Repeater System Module
270-3240-020
Installation Manual

Proprietary Notice

NOTICE: The contents of this document are proprietary to Rockwell Collins, Inc. and shall not be disclosed, disseminated, copied, or used except for purposes expressly authorized in writing by Rockwell Collins, Inc.

Export Notice

The technical data in this document (or file) is controlled for export under the Export Administration Regulations (EAR), 15 CFR Parts 730-774. Violations of these export laws may be subject to fines and penalties under the Export Administration Act.

© Copyright 2009 Rockwell Collins, Inc. All rights reserved.

Prepared by:

Dave Philipp Date
System Engineer

Approved by:

Cris Johnson Date
Engineering Manager

Approved by:

Deborah Braid Date
Technical Project Manager

Approved by:

Jason Heimer Date
Program Manager



This page is intentionally left blank.

FCC COMPLIANCE

This device complies with Part 15 of the FCC Rules. Operation is subject to the following two conditions:

1. This device may not cause harmful interference
2. This device must accept any interference received, including interference that may cause undesired operation.

WARNING: For compliance with FCC RF Exposure Requirements, the mobile transmitter antenna installation shall comply with the following two conditions:

1. The transmitter antenna gain shall not exceed 3 dBi.
2. The transmitter antenna is required to be located outside of a vehicle and kept at a separation distance of 10 inches or more between the transmitter antenna of this device and persons during operation.

WARNING: CHANGES OR MODIFICATIONS NOT EXPRESSLY APPROVED BY ROCKWELL COLLINS COULD VOID THE USER'S AUTHORITY TO OPERATE THE EQUIPMENT.

Note: This equipment has been tested and found to comply with the limits for a Class A digital device, pursuant to part 15 of the FCC Rules. These limits are designed to provide reasonable protection against harmful interference when the equipment is operated in a commercial environment. This equipment generates, uses, and can radiate radio frequency energy and, if not installed and used in accordance with the instruction manual, may cause harmful interference to radio communications. Operation of this equipment in a residential area is likely to cause harmful interference in which case the user will be required to correct the interference at his own expense.

Note: If the FCC ID is not visible when the module is installed inside another device, then the outside of the device into which the module is installed must also display a label referring to the enclosed module. This exterior label can use wording such as the following: "Contains Transmitter Module FCC ID: XEU2703240" or "Contains FCC ID: XEU2703240."

CAUTION

This unit contains static sensitive devices. Wear a grounded wrist strap and/or conductive gloves when handling printed circuit boards.



TABLE OF CONTENTS

1.0	General Description	1
1.1	Scope	1
1.2	Technical Characteristics	1
1.3	Environmental Testing Summary	1
2.0	Interface Control Drawing	2
2.1	Definitions	2
2.2	P25 Vehicle Repeater System Interface Definition	3
2.2.1	P25 VRS Antenna Connectors	4
2.2.2	P25 VRS DB-44 Connector	4
3.0	Installation Control Drawing	6
4.0	Acronyms	8



LIST OF FIGURES

Figure 1 – ICD Drawing Key 2

Figure 2 – P25 VRS System Connection..... 4

Figure 3 – P25 VRS TNC Antenna Connector (Dims in mm) 4

Figure 4 – P25 VRS SMA Antenna Connector (Dims in mm) 4

Figure 5 – P25 VRS DB-44 Connector..... 5

Figure 6 – P25 VRS Outline Drawing (dims in inches) 7



LIST OF TABLES

Table 1 – Technical Characteristics of Transceiver boards	1
Table 2 – Environmental Summary	1
Table 3 – P25 VRS DB-44 Connector Definition.....	5
Table 4 – Acronym List for VRSM Installation Manual.....	8



Document Production Software

The following software was used to produce this document.

Word Processor: Microsoft Word

Drawings: Microsoft Visio

Revision History

Date	Originator	Reason for Change
7/31/09	D. Philipp	Baseline Document
8/07/09	D. Philipp	Revised Information
8/08/09	D. Philipp	Revised Information

1.0 GENERAL DESCRIPTION

1.1 SCOPE

This document provides the installation instructions of the Rockwell Collins Vehicle Repeater System Module (VRSM), part number 270-3240-020. The unit is intended for use by government agencies or contractors thereto whom have obtained licensing within the frequency range listed in Table 1 below.

The Rockwell Collins VRSM is a full duplex P25 radio module consisting of two Nexus XR25 transceivers capable of operating in the 764 MHz to 869 MHz frequency range. The VRSM has the ability to operate in both analog and digital communications.

The purpose of the VRSM is to allow a portable radio to transmit and interface with a mobile radio while repeating the transmission to other portable radios in the area on the selected channel. The VRSM is capable of programming frequency, CTCSS tones, and P25 Network Access Codes (NAC) information. In addition, the RF power output can be adjusted from 0.1W to 2.0W to reduce interference with other nearby systems.

1.2 TECHNICAL CHARACTERISTICS

The VRSM consists of two identical transceiver boards. Table 1 describes the high level specifications for the transceiver.

Table 1 – Technical Characteristics of Transceiver boards

Feature	Figure
Tx Frequency Range	769.15 MHz to 770 MHz
Rx Frequency Range	769.15 MHz to 770 MHz and 799.15 MHz to 800 MHz
Channel Spacing	12.5 kHz/25kHz
Modulation	Narrowband Analog FM/ Wideband Analog FM/ P25 Digital Voice and Data
RF Output Power	0.1W – 2W
Voltage Required	9.0 – 19.0 Volts
Amperage Required	4 Amps Max
Operating Temperature	-20° C to +60° C

1.3 ENVIRONMENTAL TESTING SUMMARY

Table 2 shows the environmental testing of the VRSM.

Table 2 – Environmental Summary

Standard	Title/Section
MIL-STD-810F	514.5 Procedure I (Vibration)

MIL-STD-810F	516.5 Procedure I (Shock)
MIL-STD-810F	506.4 Procedure II (Rain)
MIL-STD-810F	510.4 Procedure I (Sand and Dust)
MIL-STD-810F	509.4 Procedure I (Salt Fog)
MIL-STD-810F	502.4 Procedure I & II (Low Temperature)
MIL-STD-810F	501.4 Procedure I & II (High Temperature)
MIL-STD-810F	507.4 Procedure I (Humidity)

2.0 INTERFACE CONTROL DRAWING

2.1 DEFINITIONS

For the drawings in this ICD, Figure 1 below defines the key for each drawing.

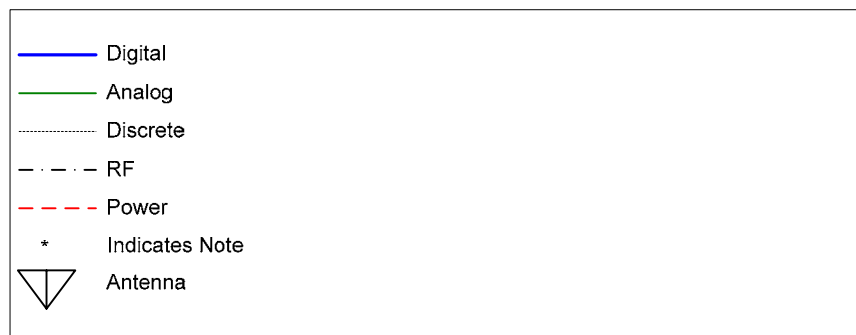

Figure 1 – ICD Drawing Key

For the tables in this ICD, the following definitions shall be used:

Function: Function is the description of the pin(s) and what data should be expected from it. Function should include what protocol and/or intended use. Function usually is fairly descriptive of the function being performed on that pin or set of pins, i.e. “Mobile PTT Output”, or “RS-232.”

Signal Type: Signal Type is the kind of signal/message being sent. Signal Types can be Ground, Analog, Serial Digital, G/O Discrete, RF, 12VDC Battery, etc.

I/O: I/O is the direction of the signal, I (Input), O (Output), or G (Ground Return).

Pin: Pin is the physical pin or wire number on the connector. It may also be the wire color in the cases where pins are not numbered.

Comments: Comments will contain any information pertinent to the pin. This might include voltage levels, current limits, impedance limits, wire types, or even a longer description of the intended use of the pin.

2.2 P25 VEHICLE REPEATER SYSTEM INTERFACE DEFINITION

This Interface Control Drawing (ICD) provides a description of the interfaces within the VRSM. Logical interfaces are defined as digital communication paths represented by industry digital standards such as the EIA/TIA/RS-232 standard. The ICD provides connection diagrams, and pin descriptions with logical interface protocol information.

The VRSM contains a pair of RF connectors to interface with antennas. These connectors are detailed out in Section 2.2.1. Internally, all interfaces on the XR-25 transceiver boards are brought out to a single connector. Each transceiver board has an RF side and a digital side, where the single connector is brought out on the digital side. The connector is referred to as the “host interface connector.” Each of the two transceiver boards will reside on a carrier board within the module housing. The carrier board will provide power filtering, audio attenuation, and digital signal level conversion. The carrier board has the power and data connections to the external surface which is detailed in 2.2.2. Figure 2 below details the connection of the VRS to the system.

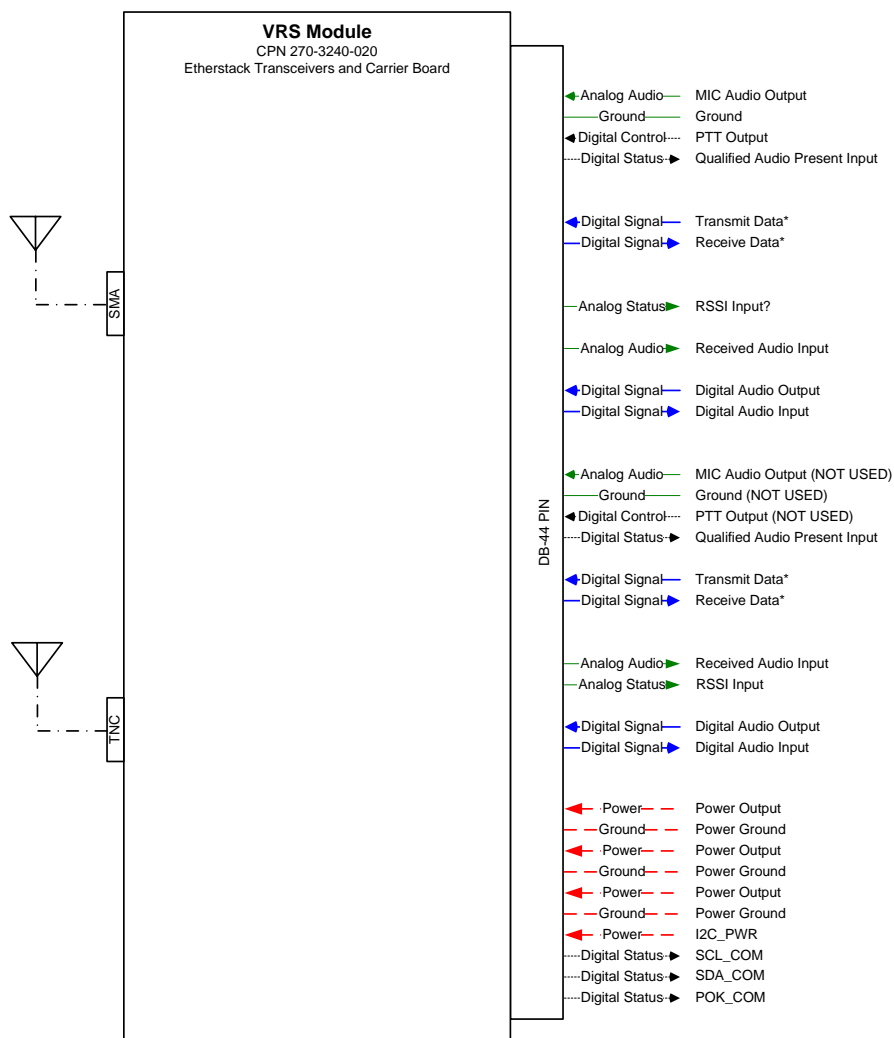

*Note – Control and Radio Programming are accomplished through the serial connections.

Figure 2 – P25 VRS System Connection

2.2.1 P25 VRS ANTENNA CONNECTORS

There are two antenna connectors on the P25 VRSM. One is a TNC type connector (Figure 3) and the other is a SMA type connector (Figure 4). These antenna ports shall not be connected to an antenna with a gain greater than 3dBi.

Internally, these connectors attach via cabling to the individual transceiver cards inside the VRSM. The TNC connector is a TNC Bulkhead Jack G3 (RG-178B/U), IP 67 rated, Telegärtner brand connector, part number J01011A2336. The SMA connector is a SMA female-female hermetic bulkhead adaptor, Radiall brand connector, part number R125.753.000.

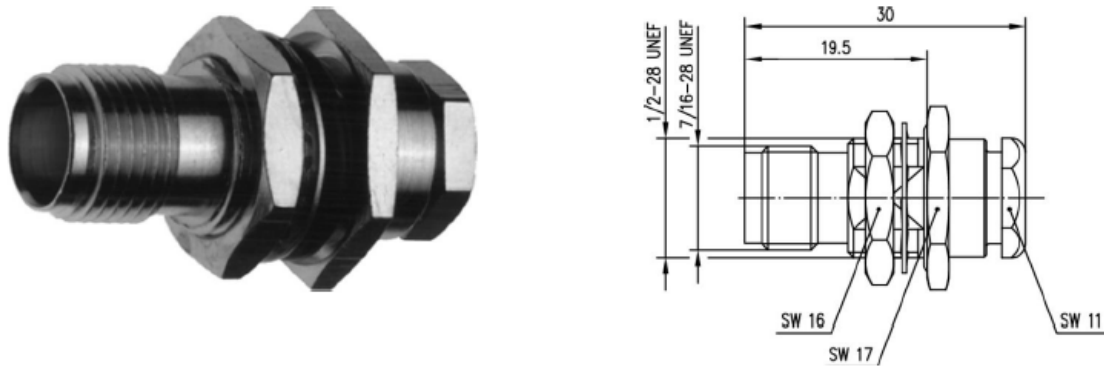

Figure 3 – P25 VRS TNC Antenna Connector (Dims in mm)

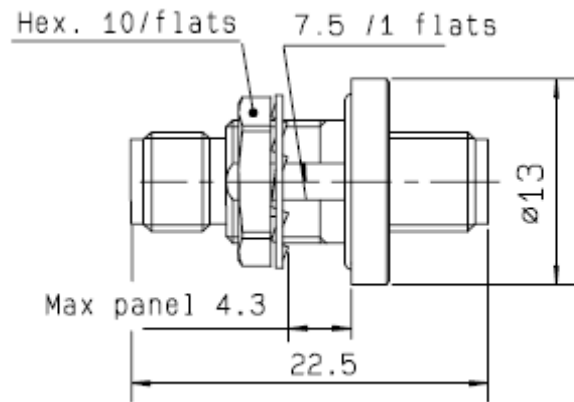

Figure 4 – P25 VRS SMA Antenna Connector (Dims in mm)

2.2.2 P25 VRS DB-44 CONNECTOR

The DB-44 Connector on the P25 VRSM is defined in Figure 5. The DB-44 Connector is a CONEC brand, part number 6HDD44PCY99R40X.



Figure 5 – P25 VRS DB-44 Connector

Electrical signal characteristics of the DB-44 connector are listed in Table 3.

Table 3 – P25 VRS DB-44 Connector Definition

Function	Signal Type	I/O	Pin	Comments
MIC Audio Input 1	Analog Audio	I	35	300mV RMS 60% deviation
	Ground	G	21	Ground
PTT Input 1	CMOS	I	40	3.3V signal (0.8V low) 1K load Max, Driven Open Collector from the BCM
RS232 – Radio Control & Programming 1	TTL RXD	I	14	UART control and programming to VRS module 1 from BCM. This signal should be non-inverted. 3.3V signal (0.8V low 2.0V high) 1K load
	TTL TXD	O	15	UART control and programming from VRS module 1 to BCM. This signal should be non-inverted. 3.3V signal (0.4V low 2.4V high) 4ma drive
Qualified Audio Present Output 1	CMOS	O	42	3.3V signal (0.4V low 2.4V high) 4ma drive – Programmable to be Active High or Active Low
Received Audio Output 1 & 2	Analog Audio 1	O	35	300mV RMS 60% deviation
	Analog Audio 2	O	36	300mV RMS 60% deviation
	Ground	G	24	Analog Input Audio Ground
Digital Audio 1	UART TXD	O	9	UART digital audio stream from VRS module 1 to BCM. This signal should be non-inverted. 3.3V signal (0.4V low 2.4V high) 4mA drive
	UART RXD	I	6	UART digital audio stream to VRS module 1 from BCM. This signal should be non-inverted. 3.3V signal (0.8V low 2.0V high) 1K load
MIC Audio Input 2	Analog Audio	I	36	300mV RMS 60% deviation
	Ground	G	37	Ground
PTT Input 2	CMOS	I	41	3.3V signal (0.8V low) 1K load Max, Driven Open Collector from the BCM
RS232 – Radio Control &	TTL RXD	I	29	UART control and programming to VRS module 2 from BCM. This signal should be non-inverted. 3.3V signal (0.8V Low 2.0V High) 1K load

Function	Signal Type	I/O	Pin	Comments
Programming 2	TTL TXD	O	30	UART control and programming from VRS module 2 to BCM. This signal should be non-inverted. 3.3V signal (0.8V low 2.0V high) 4mA drive
Qualified Audio Present Output 2	CMOS	O	43	3.3V signal (0.4V low 2.4V high) 4ma drive – Programmable to be Active High or Active Low
Digital Audio 2	UART TXD	O	8	UART digital audio stream from VRS module 2 to BCM. This signal should be non-inverted. 3.3V signal (0.4V low 2.4V high) 4mA drive
	UART RXD	I	5	UART digital audio stream to VRS module 2 from BCM. This signal should be non-inverted. 3.3V signal (0.8V low 2.0V high) 1K load
Power Input	12V Power	I	31	9V to 19V, 4A current limit
	12V Power	I	32	9V to 19V, 4A current limit
	12V Power	I	33	9V to 19V, 4A current limit
	Ground	G	1	VRS board power return signal
	Ground	G	16	VRS board power return signal
	Ground	G	17	VRS board power return signal
I2C_POW	Power	I	19	I2C 3.3V Power. This power is only used for the EEPROM and the Temp Sensor on the VRS module. Current limited and controlled by the MCM on the BCM.
SCL_COM	G/O Discrete	O	18	I2C data clock for the EEPROM and the Temp Sensor. This signal is part of the module detection. 3.3V signal.
SDA_COM	G/O Discrete	O	3	3.3V Signal (0.8V Low, 2.0V High), 1K Load. I2C Data Bus for the EEPROM and the Temp Sensor. This signal is part of the module detection.
POK_COM	G/O Discrete	O	34	Active high power OK signal to the MCM. Should indicate all power supplies are good on the VRS modules. 3.3V signal (0.4V low 2.4V high) 1ma drive

3.0 INSTALLATION CONTROL DRAWING

Figure 6 below shows the overall outline drawing (physical dimensions) of the VRSM. The drawing details out the centerlines of all connectors on the external surface.



Vehicle Repeater System Module
Installation Manual

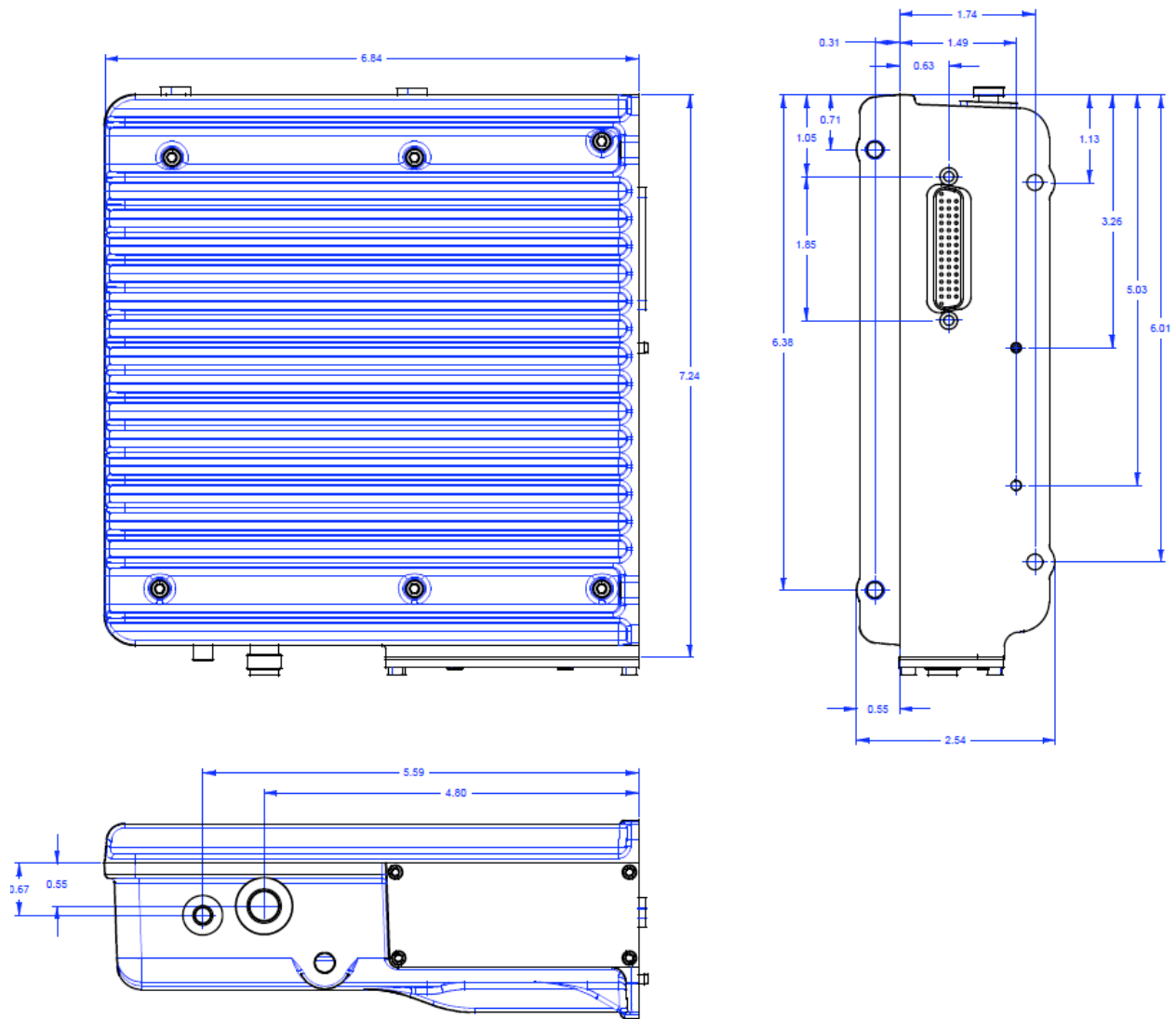

Figure 6 – P25 VRS Outline Drawing (dims in inches, not to scale)

4.0 ACRONYMS

Table 4 – Acronym List for VRSM Installation Manual

Acronym	Definition
A	Ampere
BNC	Bayonet Neill-Concelman
dBi	decibel isotropic
EEPROM	Electrically Erasable Programmable Read-Only Memory
G	Ground Return
I	Input
ICD	Interface Control Drawing
kHz	Kilohertz
ma	Milli-Amp
MIC	Microphone
mm	Millimeters
O	Output
POK_Comm	Power
PTT	Push to Talk
RMS	Root Mean Square
RSSI	Received Signal Strength Indication
RXD	Receive Digital
SCL_Comm	Serial Clock
SDA_Comm	Serial Data
SMA	Sub-Miniature version A
TNC	Threaded Neill-Concelman
TXD	Transmit Digital
UART	Universal Asynchronous Receiver/Transmitter
VRS	Vehicle Repeater System
VRSM	Vehicle Repeater System Module
W	Watt