

RMR-8RD

Advanced Micro Technology Design
Remote Radar Detector with Voice Alert System
360° Radar and Laser Detector

1. INTRODUCTION

Dear Rocky Mountain Radar Owner,

Congratulations on your purchase of one of the world's most sophisticated remote radar and laser detector. The Rocky Mountain Radar's remote is a completely integrated radar and laser detector which responds not only to all the radar guns in use today, but also to the other latest development in speed monitoring devices - the laser guns.

The RMR-8RD provides distinct visual and voice alerts to warn you of the presence of X, K, and all kinds of Ka Band radar guns in the front and rear of you. This remote also provides the benefit of undetectability by alerting you to the presence of VG-2(The radar detector detector).

It also incorporates a new safety feature Safety Alert(SA) and Safety Warning System(SWS). This safety feature warns you of the presence of potential road hazards by detecting signals from safety radar transmitting devices.

Note:

Important: The RMR-8RD is not designed to help you disobey the law. A defensive driver always obeys the posted speed limit and legal driving methods.

Federal and Local Regulations

The FCC passed the Communications Act in 1934 to give all citizens the right to receive all types of radio transmissions. The same radio frequencies used by police radar are also used by other devices, such as automatic door openers, burglar alarms, and some amateur radio equipment. Since this remote is just a radio receiver tuned to a specific portion of the public radio spectrum, it is protected under this act.

Some local, state, and federal regulations may prohibit the use of this detection device. Please check with authorities regarding the use of this device before operating it.

2. COMPONENTS

Your RMR-8RD remote package consists the following components;

- (1) Display Box
- (1) Front Antenna for radar and laser detection
- (1) Rear Antenna for laser detection
- (2) Mounting Bracket
- (2) Dual Lock Tape for front and rear antennas
- (1) Velcro Tape for display box
- (4) Special Screw for installation of the bracket with antenna
- (10) Washer Screw for mounting the brackets on the car
- (10) Cable Tie
- (1) Coiled 12V DC Power cord
- (1) Manual

3. INSTALLATION

A. **Front Antenna:** It is very important that the front antenna is mounted properly.

***Determine the best location for the front antenna. The optimal location for mounting the front antenna depends on the vehicle's type. In most vehicles the best mounting location is directly behind the grill; however, other locations which provide concealment and/or protection of the antenna may be acceptable.**

***Using the supplied mounting brackets, mark location. Drill pilot holes in the vehicle if necessary.**

***Fit the mounting brackets using the washer screws.**

***Make sure that the lens of the front antenna faces to the driving direction.**

***You can use the included Dual Lock tape to attach the mounting brackets. Thoroughly clean any surface before the tape is applied.**

Note:

***DO NOT drill holes in the front antenna itself.**

***Thoroughly investigate location before drilling any holes.**

*Keep all cables away from moving parts and hot surfaces (Radiator, hoses, engine, etc.).

*Make certain that the antenna is level and has a "clear view" of the road.

B. Rear Antenna: The rear antenna detects the laser signals received from the rear.

*Determine the best location for the rear antenna. For optimum performance, install the rear antenna on either side of the rear license plate, above third brake light on rear deck.

*Using the supplied mounting bracket, mark location. Drill pilot holes in the vehicle if necessary.

*Fit the mounting brackets using the screws provided.

C. Display Box

*Determine the best location for the display box in the vehicle's interior.

*Install display box using the supplied Velcro tape.

*Route cable and plug into jack.

*The cable from the front antenna plugs into front jack; rear antenna plug goes into rear jack.

Note: Make certain that the display box is clearly visible from the driver's position and that the controls can be easily accessed without interfering with normal driving.

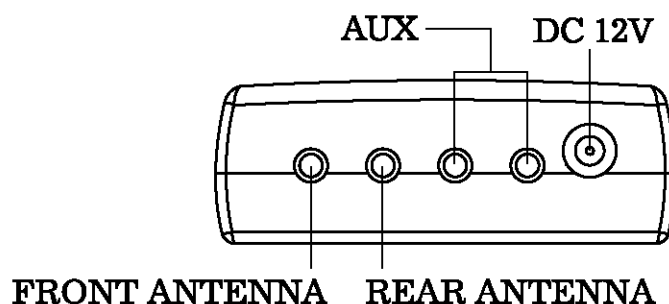

D. Front Antenna Cable

*Route front antenna cable to firewall and secure with supplied cable ties.

*Detour the cable around any moving parts and hot surface, then fasten secure with the supplied cable ties.

*Route the cable into the vehicle's interior.

*Pull the cable through firewall and plug into jack marked " FRONT " of the display box.

Note: Keep the antenna cable away from any areas in the engine compartment that may become very hot. Cable ties are provided to secure the antenna cable at various points in the engine compartment.

E. Rear Antenna Cable

*Route the cable through trunk compartment and into the vehicle's interior.

*Pull the cable and plug into jack marked "REAR" of the display box.

F. TEST: After all components are installed correctly, turn the display box on by pressing the power button. Turning on the detector triggers the Self-Test mode.

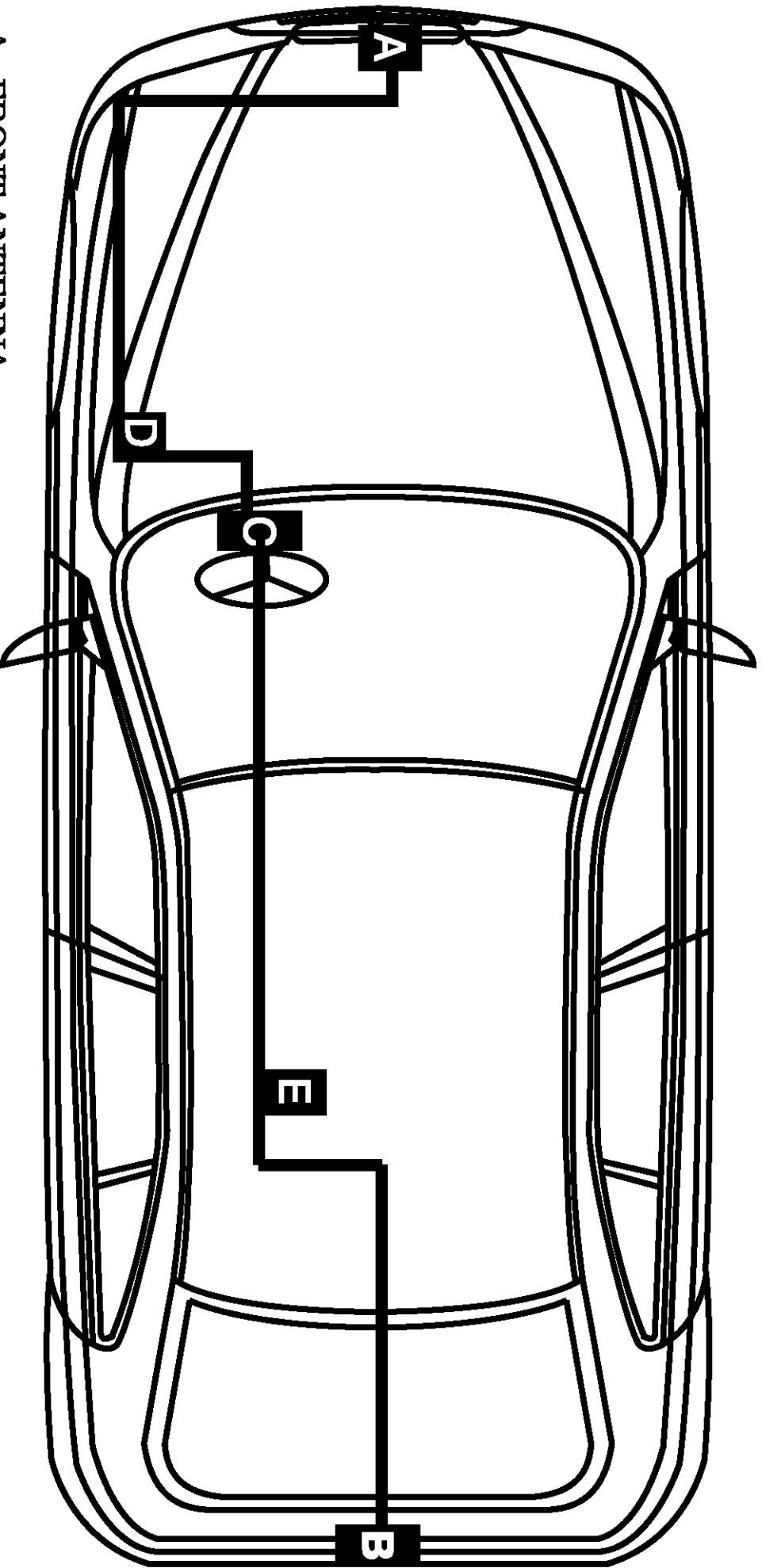

- A : FRONT ANTENNA
- B : REAR ANTENNA
- C : DISPLAY BOX
- D : FRONT ANTENNA CABLE
- E : REAR ANTENNA CABLE

4. OPERATION

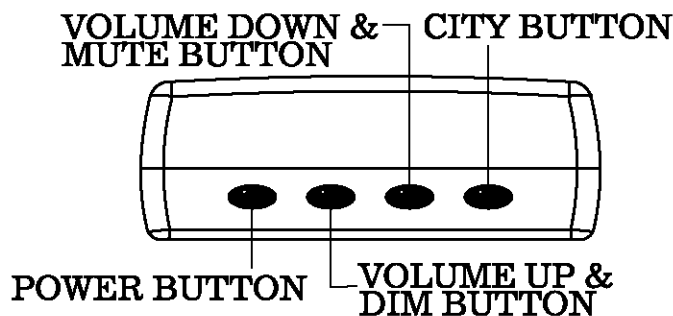

* Power Button

- Press the power button to turn the remote on. The remote goes through a self-test sequence and displays the last mode previously set in memory.
- Hold down power button for two (2) seconds to select "Voice On" or "Voice Off".

* Volume Level Adjustment

- Press Volume up button (V/U) to increase volume level
- Press Volume down button (V/D) to decrease volume level.

NOTE: Press the V/U (DIM) or V/D (MUTE) buttons for less than 2 seconds each time to adjust the volume level. Press and hold the V/U (DIM) and V/D (MUTE) buttons for more than 2 seconds to engage DIM and MUTE functions.

* Display Brightness Control

- There are four levels of brightness for the display.
- Hold down the DIM button for two (2) seconds. Each time you hold down the DIM button for two (2) seconds, the display brightness will change (Dim, Dimmer, Dark, and Bright).

(Note: The remote cannot activate Mute and Dark at same time. If the MUTE is engaged, the DARK cannot be activated.)

*** Mute Button**

- Hold down the MUTE button for two (2) seconds, this will silence the tone sound.
- Hold down the MUTE button for two (2) seconds to engage the Auto Mute feature. The voice " Mute Two On " will alert you that Auto Mute has been engaged.
- In Auto Mute mode the remote will announce the radar bands then beep four times before going silent. It will remain silent for two minutes or until it detects a new radar band(s). The remote will repeat this cycle in Auto Mute mode.
- Hold down the MUTE button for two (2) seconds to restore tone sound.

*** City and Highway Mode**

Two step City modes are designed to reduce false alarms while you are driving in or near urban areas where there are many sources for conflicting X band signals such as microwave towers and automatic door openers.

- Press the City button to engage "City 1" mode.
- Press the City button a second time to engage "City 2" mode.
- Press the City button a third time to engage "Highway" mode
- In "City 1" mode, X band will be turned off without affecting K/Ka sensitivity.
- In "City 2" mode, X band will remain off and K/Ka sensitivity will be reduced by 50%

*** Select Tone**

- Press the Power and City buttons simultaneously. The remote will change tone sound.

*** Language Selection (English and Spanish)**

- Factory default is "English".
- Press the Power and Dim (Volume up) buttons simultaneously to select either English or Spanish for your voice alert system.

*** Voice Selection**

- Factory default is "Voice On" mode.
- Hold down the Power button for two (2) seconds to select Voice On or Voice Off mode.
- When you drive with Voice Off mode, you will not be alerted by voice.

*** VG-2 Selection**

- Factory default is "VG-2 On".
- Hold down the City button for two (2) seconds, the remote will disengage VG-2 feature.
- Press the City button a second time for two (2) seconds, the remote will engage VG-2 feature.

*** Tutorial Mode**

The RMR-8RD remote has a tutorial mode intended to familiarize you with the various visual display and distinct audible alerts this unit performs.

- Press the Power and Mute (Volume down) buttons simultaneously to engage tutorial mode.
- Press any button to exit the All-LEDs-On status; that ends the tutorial mode.

*** Feature Memory**

The memory will automatically remember your settings when the unit is turned off or removed from the power. All features selected are retained in memory.

- Bright - Dim - Dimmer - Dark
- Audio Tone
- Mute On - Auto Mute - Mute Off
- Voice On or Voice Off
- English or Spanish
- VG - 2 On or VG - 2 Off
- Volume level
- City or Highway

*** Indicator and Visual**

A. Power On : "P" LED turns on.

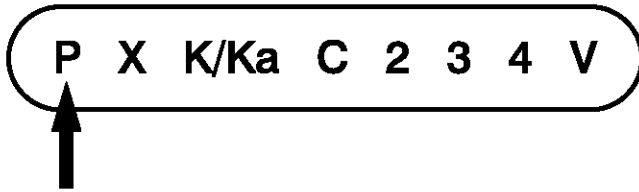

B. X Band Detection : " X" LED turns on with voice sound.

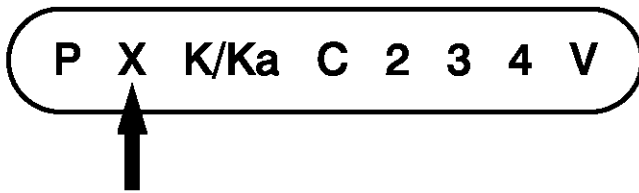

C. K/Ka Band Detection: "K/Ka" LED turns on with voice sound.

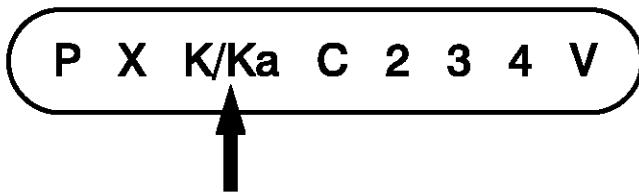

D. Laser Alarm : If the front antenna detects the laser signal, "P, X, K/Ka" LEDs will flash. If the rear antenna receives the laser signal, "2, 3, 4" LEDs will flash.

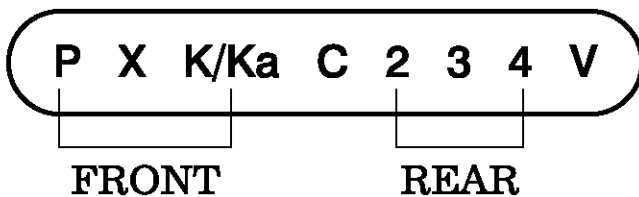

E. VG-2 Alarm : "V" LED flashes with voice sound.

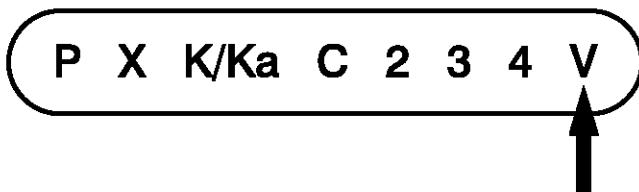

5. CARE AND MAINTENANCE

Your RMR-8RD remote is an example of superior design and craftsmanship. The following suggestions will help you care for your remote so you can enjoy it for years.

- Never leave your display box on the dashboard when your vehicle is left parked. The temperature in the vehicle during the summer can reach levels above what is considered to be safe for this display box.
- To make you less susceptible to break-ins and theft, remove the display box from your dashboard when leaving your vehicle.
- Try to avoid road splash or other liquids that can damage the internal components and reduce the performance of the detector. Periodically check and wipe off any dirt from front and rear antennas. Use a soft cloth to avoid scratching the lens.

6. TROUBLESHOOTING

If the display box does not turn on:

- Check the power cord. Be sure all power cord connectors are properly installed.
- Check the fuse that controls the power to the cigarette lighter socket.
- The cigarette lighter socket might be dirty. Clean it with a fine cloth to ensure a good, clean connection.
- There might be a problem with the vehicle's electricity.
- Be sure to press the power button.

Caution: Do not place any metal objects other than the cigarette lighter or a cigarette lighter plug in the cigarette lighter socket. Doing so could blow a fuse in your vehicle or cause the metal object to become very hot.

If the remote gives a false alert when the vehicle hits bumps:

- Check the vehicle's electrical system including main battery cable and alternator connections.

- Install a filter capacitor (470 μ F, 35 volts) on the back of the cigarette lighter socket, across the power connection.

If the remote does not seem sensitive to radar or laser

- Make sure that the front and rear antennas are not obstructed.
- Relocate the front and rear antennas to a clear view of the road.
- Make sure the antenna cables are correctly connected with display box.

7. FUSE REPLACEMENT

The lighter socket adapter of the power cord has a replaceable 2 Amp SAG fuse located below the silver tip. To check or replace the fuse, slowly and carefully unscrew the tip of the plug, making sure the spring and silver tip located inside the plug do not fly out when you remove the cap. Check fuse and replace if necessary.

8. SPECIFICATION

RADAR

Receiver Type: Dual conversion Superheterodyne

Antenna Type: Linear polarized, Self - Contained Antenna

Detector Type: Scanning Frequency Discriminator

Frequency of Operation: 10.525GHz/ \pm 50MHz(X Band)

24.150GHz/ \pm 100MHz(K Band)

34.700GHz/ \pm 1,300MHz(Ka Super Wideband)

LASER

Receiver Type: Pulsed Laser Signal Receiver

Detector Type: Digital Signal Processor Pulse
Width Discriminator

Opto Sensor: Dual Convex Condenser Lens and High Speed Photo Diode
Detector

Spectral Response: 800 ~ 1,100nm

GENERAL

Temperature Range: -4 to 158°F (-20 to 70°C)

Power Requirements: 12~15V DC, 80mA nominal (Negative Ground)

Specifications are subject to change without notice.

9. WARRANTY

This unit is guaranteed against defects in workmanship and materials for one year. Should you experience any difficulty with the RMR-8RD remote during this time, the unit will be repaired or replaced at no charge.

Should you desire to have your unit checked, there will be no additional charge other than postage and handling. After the warranty period expires, the unit may be returned for service and it will be reconditioned for a nominal fee; contact factory for service.

10. FCC Information

This product has been designed and certified to comply with Part 15 of the FCC Rules. Operation is subject to the following two conditions: (1) this device may not cause harmful interference, and (2) this device must accept any interference received, including interference that may cause undesired operation.

Any changes or modifications not expressly approved by Rocky Mountain Radar may void your authority to use this product.

1. INTRODUCTION

Dear Rocky Mountain Radar Owner,

Congratulations on your purchase of one of the world's most sophisticated remote radar and laser detector. The Rocky Mountain Radar's remote is a completely integrated radar and laser detector which responds not only to all the radar guns in use today, but also to the other latest development in speed monitoring devices - the laser guns.

The RMR-8RD provides distinct visual and voice alerts to warn you of the presence of X, K, and all kinds of Ka Band radar guns in the front and rear of you. This remote also provides the benefit of undetectability by alerting you to the presence of VG-2(The radar detector detector).

It also incorporates a new safety feature Safety Alert(SA) and Safety Warning System(SWS). This safety feature warns you of the presence of potential road hazards by detecting signals from safety radar transmitting devices.

Note:

Important: The RMR-8RD is not designed to help you disobey the law. A defensive driver always obeys the posted speed limit and legal driving methods.

Federal and Local Regulations

The FCC passed the Communications Act in 1934 to give all citizens the right to receive all types of radio transmissions. The same radio frequencies used by police radar are also used by other devices, such as automatic door openers, burglar alarms, and some amateur radio equipment. Since this remote is just a radio receiver tuned to a specific portion of the public radio spectrum, it is protected under this act.

Some local, state, and federal regulations may prohibit the use of this detection device. Please check with authorities regarding the use of this device before operating it.