

Hi!

Let's get started.



Roku

What's in the **box**



Roku
Streaming
Stick

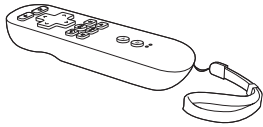

Enhanced
remote control

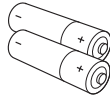

2 x AA
batteries for
remote

What you **need**

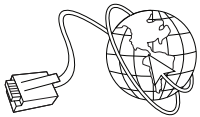

High speed
Internet

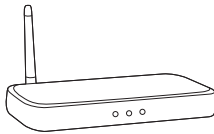

Wireless
Router

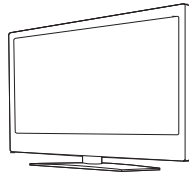

TV with
MHL port



Know your **Streaming Stick**

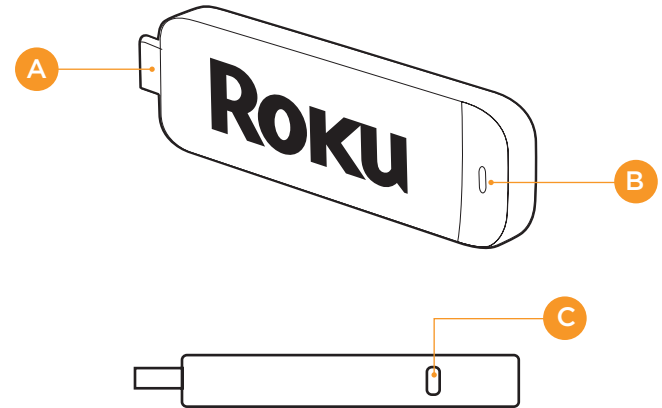

- A** [MHL CONNECTOR] Plugs into the MHL port on the back of your TV.
- B** [STATUS LIGHT] Signifies it is on when lit.
- C** [RESET BUTTON] Used to reset your Streaming Stick (you probably won't ever have to use this).

What to do

Plug it in

Plug your Roku Streaming Stick into the MHL port on the back of your HDTV. Simple as that!

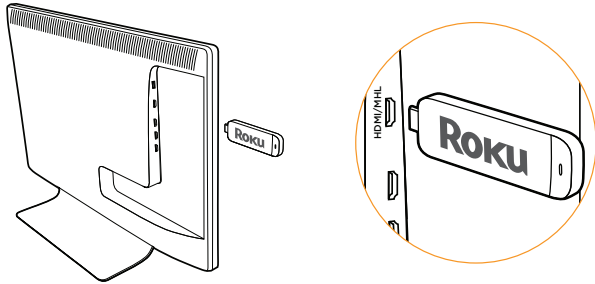

Power up

First, power your Roku remote by inserting the included batteries:

- Locate and open the rectangular battery door on the rear of the unit.
- Insert the batteries into their slots, making sure to match the positive (+) and negative (-) signs.
- Place the battery door back over the compartment and press it gently down until the latch snaps securely into place.

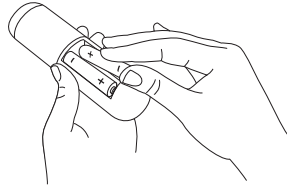

Connect to network

Now you can grab that Roku remote and jump right into Guided Setup. When prompted, select “Wireless” as your network connection and have your network name and password ready to do the following:

- Select your network from the list of available networks.
- Enter your network password, if you use one. Remember, network passwords are case sensitive.

Complete guided setup

It's the final stretch and hooray—it's a breeze! Continue following the on-screen instructions and you'll:

- Get the latest software.
- Select the video output resolution.
- Link the Roku player to your Roku account on your computer.



Your Roku account: During Guided Setup, you'll be prompted to create your Roku account online at roku.com/link. Your Roku player will generate a unique code that links your player to your new account. Roku accounts are free and secure. And while a valid credit card number is required to create your account, rest assured you will only be charged if you authorize purchases of apps and games from the Roku Channel Store.

Know your Roku remote

The Roku remote should feel right at home in your hand. We designed it to be incredibly intuitive for watching TV and great for gaming, too!

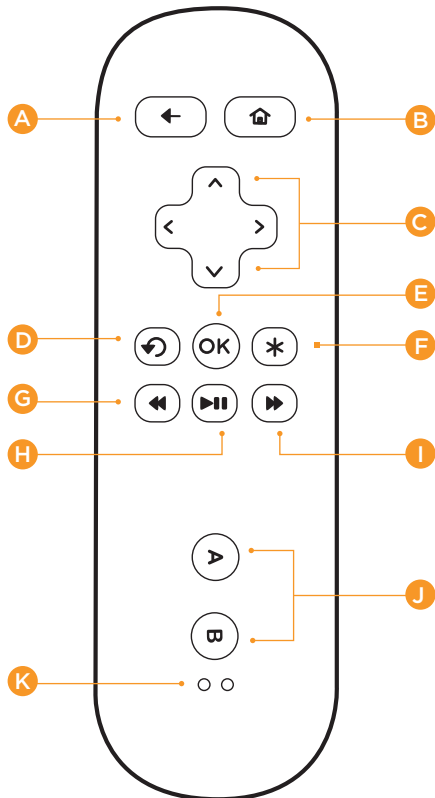

- A** [BACK] Return to previous screen
- B** [HOME] Return to Roku home screen
- C** [UP] or [DOWN] Move up or down; [LEFT] or [RIGHT] Move left or right
- D** [INSTANT REPLAY] Replay last 7 seconds of video
- E** [OK] Select an option from a menu
- F** [OPTIONS] View more options
- G** [REV SCAN] Rewind, scroll left one page at a time
- H** [PLAY/PAUSE] Start or pause playback
- I** [FWD SCAN] Fast forward, scroll right one page at a time
- J** [A & B] Action buttons for gaming
- K** [Status LED] Displays remote usage information

Cool: Because your enhanced remote uses radio frequency instead of infrared, you don't need to have a direct line of sight to your Roku!

Get your game on!

Just a couple of fun-facts about your Roku enhanced remote.

- It's sensitive and smart. The Roku remote incorporates motion-sensing technology, allowing more precise and detailed control of gameplay.
- It comes with an adjustable wrist strap—for good reason. Since some games make you sweat, sporting the wrist strap is a very good idea. You don't want to crack the screen of your beautiful TV—or harm anyone or anything around you.

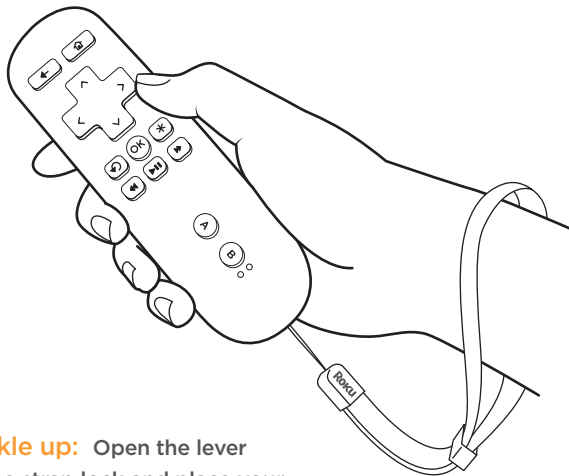

Buckle up: Open the lever on the strap lock and place your hand through the wrist strap. Hold the remote firmly in your hand. Slide the strap lock up so that the strap will not fall off your wrist. Do not over-tighten the strap lock so that it's uncomfortable.

Troubleshooting

Having trouble completing Guided Setup? Don't worry: it's usually an easy fix.

If you cannot see a picture on your TV:

- Make sure your TV is turned on. (This tip could save you some embarrassment.)
- Make sure the video input on your TV or home theater receiver is set to match the output (usually HDMI or MHL) used with the Roku Streaming Stick. Most TVs have an Input button on the remote control to change video inputs.

If you cannot connect to your wireless home network during guided setup:

- If you are not getting 3 or more signal-strength bars above your wireless network, adjust the location of your Roku Streaming Stick and/or wireless router. Make sure there are no obstructions, like cement walls, between your Roku Streaming Stick and your wireless router.
- Make sure you select the correct wireless router name on the "Wireless" screen.
- Make sure you input the correct password, if your network is security-enabled (password is case sensitive).
- If you have turned off SSID broadcasting on your wireless router, you can add your network by selecting "Add network" from the "Wireless" screen.

Troubleshooting (continued)

If you cannot hear sound:

- Make sure the connectors on the cables between your TV and home theater receiver are pushed in all the way.
- Make sure the volume on your TV or home theater receiver is turned up and isn't on mute.
- Make sure the input on your TV or home theater receiver matches the output (HDMI or MHL) used with your Roku Streaming Stick.

If the Roku remote control is not functioning:

- Try moving closer to your Roku Streaming Stick.
- Make sure the batteries are working and inserted properly.
- Make sure your remote is paired (see next section) with the Roku Streaming Stick.
- If the Status Light on the front of your Roku Streaming Stick flashes once each time you press a remote button, the problem is not with the remote.

! It's unlikely but if your remote becomes warm or hot to the touch after inserting the batteries, immediately discontinue use. Do not attempt to remove the batteries while the unit is hot. Contact Roku Customer Support immediately at 888-600-7658

Pairing your remote control:

The Roku remote should automatically pair with your Roku Streaming Stick at the beginning of Guided Setup. If you are not able to use the remote to navigate through Guided Setup, you can manually pair the Roku remote by following these steps:

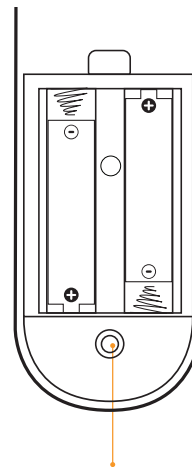

- 1 Be sure to turn off or move other devices that are near the Roku Streaming Stick.
- 2 Open the Roku remote battery compartment using the instructions in Step 2.
- 3 Place the Roku remote in close proximity with your Roku Streaming Stick.
- 4 Press and hold the pairing button inside the battery compartment for 3 seconds.
- 5 Try using the remote again.

If you couldn't find what you need:
Visit roku.com/support for more help.

Need more **help?**

roku.com/support

Get the most out of your Roku Streaming Stick. Check out our FAQs, instructional videos and user forums.

Roku®

© 2009-2012 by Roku, Inc. All rights reserved. Roku and the Roku logo are registered trademarks of Roku, Inc. Other brand and product names are trademarks or registered trademarks of their respective holders.

Roku Streaming Stick

Important Product Information

The License Agreement

The Roku and third-party software license terms can be found at: www.roku.com/license. Use of the Roku Streaming Stick ("**Streaming Stick**") constitutes acceptance of as well as agreement to those license terms.

Ninety (90) Day Limited Hardware Warranty

Subject to the additional terms and conditions set forth below, Roku provides this Limited Warranty:

- Only to the person or entity that originally purchased the Streaming Stick from Roku or from one of its authorized re-sellers or distributors; and
- Only for Streaming Sticks purchased and delivered to the end user within the United States and Canada.

Limited Warranty

Roku warrants the Streaming Stick hardware against defects in materials and workmanship under normal use for a period of ninety (90) days from the date of purchase ("**Warranty Period**"). If Roku determines that the Streaming Stick's hardware is defective, Roku will either repair the unit or replace the unit with either a new or rebuilt Streaming Stick, at its option. If the Warranty Period has expired or is otherwise not applicable (see **Scope and Limitation on Warranty** below), we will return the Streaming Stick to you. More information about this warranty can be found at www.roku.com/support. THE FOREGOING SETS FORTH ROKU'S SOLE OBLIGATION AND YOUR EXCLUSIVE REMEDY IN THE EVENT OF ANY BREACH OF THIS LIMITED WARRANTY.

Return and Warranty Service Process

Please access and review the online help resources at www.roku.com/support before seeking warranty service. To return or obtain warranty service for a Streaming Stick, you must first obtain a Return Merchandise Authorization (RMA) number from a Customer Support Representative (CSR) at Roku. Customer Support contact information can be found by visiting www.roku.com/support. RMA numbers expire thirty days from issuance. Roku may attempt to troubleshoot a warranty-related problem prior to issuing a RMA number. Please be prepared to provide additional information upon request. Once a RMA number is obtained, you must ship your

Streaming Stick, freight prepaid, together with proof of purchase and all accessories, in either the original packaging or packaging affording an equal degree of protection, to the Roku authorized distribution facility identified by the CSR. Failure to return any of the accessories could result in a delay and/or result in an invoice to you or credit to Roku for the missing accessories.

Important: When emailing for a RMA number, please provide the following information with your request: (a) model number, (b) serial number, (c) problem description, (d) software version (located in the System Configuration menu), (e) date of purchase, (f) place of purchase (re-seller or online place of purchase), and (g) return shipping address (P.O. boxes are not accepted).

Legal Notices

Federal Communication Commission Interference Statement

This equipment has been tested and found to comply with the limits for a Class B digital device, pursuant to Part 15 of the FCC Rules. These limits are designed to provide reasonable protection against harmful interference in a residential installation. This equipment generates, uses and can radiate radio frequency energy and, if not installed and used in accordance with the instructions, may cause harmful interference to radio communications. However, there is no guarantee that interference will not occur in a particular installation. If this equipment does cause harmful interference to radio or television reception, which can be determined by turning the equipment off and on, the user is encouraged to try to correct the interference by one of the following measures:

- Reorient or relocate the receiving antenna.
- Increase the separation between the equipment and receiver.
- Connect the equipment into an outlet on a circuit different from that to which the receiver is connected.
- Consult the dealer or an experienced radio/TV technician for help.

This device complies with Part 15 of the FCC Rules. Operation is subject to the following two conditions: (1) This device may not cause harmful interference, and (2) this device must accept any interference received, including interference that may cause undesired operation.

FCC Caution: Any changes or modifications not expressly approved by the party responsible for compliance could void the user's authority to operate this equipment.

IEEE 802.11b or 802.11g operation of this product in the U.S.A. is firmware-limited to

channels 1 through 11.

Wireless Radio Use:

This device is restricted to indoor use when operating in the 5.15 to 5.25 GHz frequency band.

IMPORTANT NOTE:

FCC Radiation Exposure Statement:

This equipment complies with FCC radiation exposure limits set forth for an uncontrolled environment. This equipment should be installed and operated with minimum distance 20cm between the radiator and your body.

This transmitter must not be co-located or operating in conjunction with any other antenna or transmitter.

Note to US model owner:

To comply with US FCC regulation, the country selection function has been completely removed from all US models.

The availability of some specific channels and/or operational frequency bands are country dependent and are firmware programmed at the factory to match the intended destination. The firmware setting is not accessible by the end user.

Safety Precautions

The Streaming Stick has been designed with the highest concern for safety. However, any electrical device, if used improperly, has the potential for causing fire, electrical shock or personal injury. To help ensure accident-free operation, follow these guidelines:

- Observe all warnings, precautions and instructions.
- Stop use, unplug the device that the Streaming Stick is inserted into from the electrical outlet and disconnect any other cables immediately if the Streaming Stick or the device functions in an abnormal manner, produces unusual sounds or smells or becomes too hot to touch.
- For more information on product safety and troubleshooting, please go to www.roku.com/support.

Use and Handling

- When playing video games, use in a well-lit area and stand or sit as far away from the screen as possible.
- Take a 10-15 minute break every hour if playing video games and avoid prolonged use of the remote.

- Stop playing video games if you begin to feel tired or if you experience discomfort or pain in your hands or arms while operating the remote if the condition persists, consult a doctor.

- If you experience any of the following health problems, discontinue use of the Streaming Stick immediately:

- Dizziness, nausea, fatigue or symptoms similar to motion sickness.

- Discomfort or pain in a part of the body, such as eyes, ears, hands, or arms.

If symptoms persist, consult your physician.

- Keep the Streaming Stick and any accessories, including the remote, out of the reach of small children.

- Do not touch the Streaming Stick during an electrical storm.

- Do not allow liquid, small particles or other foreign objects to get into the Streaming Stick or accessories.

- Do not expose the Streaming Stick to smoke or steam.

- Do not expose the Streaming Stick or accessories to high, temperatures, high humidity or direct sunlight.

www.roku.com