

Owner's Manual

Guitar Amplifier



KATANA-AIR
3 inch x 2 speaker



Transmitter

English

日本語

Deutsch

Français

Italiano

Español

Português

Nederlands

For the U.K.

WARNING: THIS APPARATUS MUST BE EARTHED

IMPORTANT: THE WIRES IN THIS MAINS LEAD ARE COLOURED IN ACCORDANCE WITH THE FOLLOWING CODE.
GREEN-AND-YELLOW: EARTH, BLUE: NEUTRAL, BROWN: LIVE

As the colours of the wires in the mains lead of this apparatus may not correspond with the coloured markings identifying the terminals in your plug, proceed as follows:

The wire which is coloured GREEN-AND-YELLOW must be connected to the terminal in the plug which is marked by the letter E or by the safety earth symbol (⊕) or coloured GREEN or GREEN-AND-YELLOW.

The wire which is coloured BLUE must be connected to the terminal which is marked with the letter N or coloured BLACK.

The wire which is coloured BROWN must be connected to the terminal which is marked with the letter L or coloured RED.

For the USA

DECLARATION OF CONFORMITY Compliance Information Statement

Model Name : KTN-AIR
Type of Equipment : Guitar Amplifier
Responsible Party : Roland Corporation U.S.
Address : 5100 S. Eastern Avenue Los Angeles, CA 90040-2938
Telephone : (323) 890-3700

For the USA

This transmitter must not be co-located or operated in conjunction with any other antenna or transmitter.

(FCC Part15 Subpart C §15.247, 15.253, 15.255)

This equipment complies with FCC radiation exposure limits set forth for an uncontrolled environment and meets the FCC radio frequency (RF) Exposure Guidelines. This equipment has very low levels of RF energy that are deemed to comply without testing of specific absorption ratio (SAR).

(FCC Part15 Subpart C §15.247, 15.253, 15.255)

For Canada

This device complies with Industry Canada licence-exempt RSSs. Operation is subject to the following two conditions:

- (1) This device may not cause interference, and
- (2) This device must accept any interference, including interference that may cause undesired operation of the device.

Le présent appareil est conforme aux CNR d'Industrie Canada applicables aux appareils radio exempts de licence.

L'exploitation est autorisée aux deux conditions suivantes :

- 1) l'appareil ne doit pas produire de brouillage;
- 2) l'utilisateur de l'appareil doit accepter tout brouillage radioélectrique subi, même si le brouillage est susceptible d'en compromettre le fonctionnement.

(RSS-Gen §8.4)

The available scientific evidence does not show that any health problems are associated with using low power wireless devices. There is no proof, however, that these low power wireless devices are absolutely safe. Low power Wireless devices emit low levels of radio frequency energy (RF) in the microwave range while being used. Whereas high levels of RF can produce health effects (by heating tissue), exposure of low-level RF that does not produce heating effects causes no known adverse health effects. Many studies of low-level RF exposures have not found any biological effects. Some studies have suggested that some biological effects might occur, but such findings have not been confirmed by additional research. WL-T has been tested and found to comply with IC radiation exposure limits set forth for an uncontrolled environment and meets RSS-102 of the IC radio frequency (RF) Exposure rules.

Les connaissances scientifiques dont nous disposons n'ont mis en évidence aucun problème de santé associé à l'usage des appareils sans fil à faible puissance. Nous ne sommes cependant pas en mesure de prouver que ces appareils sans fil à faible puissance sont entièrement sans danger. Les appareils sans fil à faible puissance émettent une énergie fréquence radioélectrique (RF) très faible dans le spectre des micro-ondes lorsqu'ils sont utilisés. Alors qu'une dose élevée de RF peut avoir des effets sur la santé (en chauffant les tissus), l'exposition à de faibles RF qui ne produisent pas de chaleur n'a pas de mauvais effets connus sur la santé. De nombreuses études ont été menées sur les expositions aux RF faibles et n'ont découvert aucun effet biologique. Certaines études ont suggéré qu'il pouvait y avoir certains effets biologiques, mais ces résultats n'ont pas été confirmés par des recherches supplémentaires. WL-T a été testé et jugé conforme aux limites d'exposition aux rayonnements IC énoncées pour un environnement non contrôlé et respecte les règles d'exposition aux fréquences radioélectriques (RF) CNR-102 de l'IC.

(RSS-102 §2.6)

Owner's Manual

Guitar Amplifier



English

日本語

Deutsch

Français

Italiano

Español

Português

Nederlands



KATANA-AIR
3 inch speaker x 2



Transmitter

An "all-wireless" guitar amp that supports wireless for guitar as well

The KATANA-AIR is a guitar amp that provides wireless connectivity for your guitar as well as Bluetooth and battery operation, making it an "all-wireless" guitar amp that lets you enjoy playing without connecting any cables to it.

Main Features

- Wireless transmitter for guitar achieves low latency. Enjoy cable-free performance.
- Four original amp types are provided: the edgy "brown" inherited from the BOSS Waza Head, as well as clean, crunch, and lead. Additionally provided is a dedicated acoustic amp that you can also use with an acoustic guitar.
- Built-in BOSS effects are easy to operate and provide high quality (up to three can be used simultaneously).
If you connect the dedicated app via Bluetooth, you can select from a total of 58 different types of effect.
- You can use headphones to enjoy sound that's as powerful as though you were hearing it from a speaker.
- Stereo audio streaming via Bluetooth is also supported.
- Two-way power supply allows operation using either eight AA batteries or an AC adaptor. Standby/Wakeup-On function lets the batteries last even longer.

Before using this unit, carefully read "USING THE UNIT SAFELY" and "IMPORTANT NOTES" (the leaflet "USING THE UNIT SAFELY" and the Owner's Manual (p. 11)). After reading, keep the document(s) where it will be available for immediate reference.

Copyright © 2018 ROLAND CORPORATION

Panel Descriptions

Top Panel

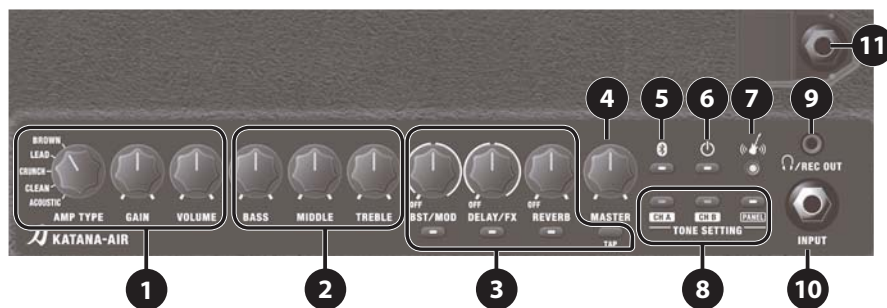

1 AMPLIFIER

[AMP TYPE] knob

Selects the amp type. All provided amp types are original.

Type	Explanation
BROWN	A lead sound with an edge inherited from the BOSS WAZA brown sound.
LEAD	Different gain settings allow this sound to cover a wide range from crunch to high-gain.
CRUNCH	A fat crunch sound that faithfully responds to the nuances of your picking.
CLEAN	A clean and natural sound. In conjunction with BST (BOOSTER), it can be used for solo or lead.
ACOUSTIC	A dedicated acoustic guitar amp that supports connection of an acoustic guitar.

[GAIN] knob

Adjusts the gain (amount of distortion).

[VOLUME] knob

Adjusts the volume.

2 EQUALIZER

[BASS] knob

Adjusts the sound level of the low-frequency range.

[MIDDLE] knob

Adjusts the sound level of middle-frequency range.

[TREBLE] knob

Adjusts the sound level of the high-frequency range.

3 EFFECTS

Here you can make settings for the built-in effects. For details on the effect types and settings for each knob, refer to "Using the Effects" (p. 6).

[BST/MOD] button/knob

Controls distortion-type effects and modulation effects.

[DELAY/FX] button/knob

Controls effects such as delay, wah, tremolo, and octave.

[TAP] button

Sets the delay time. When you press this button two or more times, the delay time is set to the interval between presses.

[REVERB] button/knob

Controls the reverb.

4 [MASTER] knob

Adjusts the overall volume.

5 [Bluetooth] button/indicator

Registers a Bluetooth Device (p. 8). And indicates the Bluetooth connection status.

Indicator	Explanation
Lit	Connected
Blinking	Pairing mode
Unlit	Not connected

6 [⏻] (POWER) button/indicator

Turn the power on/off. This also indicates the state of the power supply.

Indicator	Explanation
Lit green	On
	To enter standby mode, long-press the [⏻] button. To turn the unit off, enter standby mode and then long-press the [⏻] button.
Lit orange	Standby mode
	To turn the unit on, press the [⏻] button. To turn the unit off, long-press the [⏻] button.
Unlit	Off

MEMO

When the power is on, and a certain length of time elapses since the unit was last played or operated, the unit automatically enters standby mode. You can use a dedicated app (subsequently referred to as BOSS Tone Studio) to change the time after which the unit enters standby mode (p. 7).

In standby mode, the power automatically turns on if the transmitter plugged into the guitar detects vibration (p. 5).

7 (Guitar Wireless) indicator

Indicates the status of the connection with the transmitter.

Indicator	Explanation
Lit white	Connected with the transmitter When you play the guitar, the sound is heard from the speaker.
Unlit	Not connected with the transmitter Alternatively, the guitar is connected to the INPUT jack

* If the guitar is connected to the INPUT jack, the sound of the INPUT jack takes priority.

8 TONE SETTING

[CH A], [CH B] buttons

Each of these buttons stores three sets of settings for all top panel knobs (except the [MASTER] knob) and buttons (p. 6). Each time you press a button, the color alternates between green, red, and orange, and the settings change accordingly. If you hold down a button for one second, the settings of the sound that you're currently hearing are overwritten onto the previously-stored settings.

* You can make the settings back to the factory state by turning the power on while holding down the [PANEL] button (p. 9).

[PANEL] button

Makes the unit sound using the current settings of the panel knobs.

9 (PHONES)/REC OUT jack

Connect headphones here. You can obtain powerful guitar sounds just as if you were playing through the speaker. By using BOSS Tone Studio you can obtain the sound of different micing (LINE OUT AIR FEEL, p. 7). To adjust the volume, use the [VOLUME] knob along with the [MASTER] knob.

* If a plug is inserted in this jack, no sound will be output from the KATANA's own speaker. This is convenient if you don't want loud sound to be produced from the speaker, such as when you're practicing at night.

10 INPUT jack

You can directly connect your electric guitar here.

* To prevent malfunction and equipment failure, always turn down the volume, and turn off all the units before making any connections.

11 TRANSMITTER IN jack

You can insert the included transmitter (p. 4) here to charge it.

The first time that you use the unit, power-on the KATANA-AIR and insert the transmitter here to charge it.

NOTE

Do not insert anything other than a transmitter made by BOSS.

If you connect headphones, high-volume sound might be emitted, or the headphones might be damaged.

Rear Panel



12 AUX IN jack

Here you can connect a CD player, audio player, electronic musical instrument, or similar audio source, and listen to it while you play your guitar.

13 DC IN jack

Connect the included AC adaptor (p. 5).

* Use only the AC adaptor that was included with the unit.

14 (USB) port

You can use a commercially available USB 2.0 cable to record the sound of the KATANA-AIR into your computer.



You must install the USB driver when connecting the unit to your computer.

Download the USB driver from the Roland website. For details, refer to Readme.htm which is included in the download.

<https://www.boss.info/>

Bottom Panel

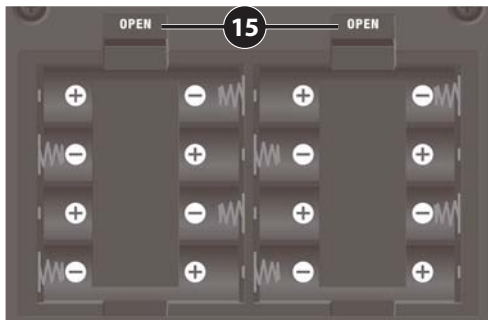

15 Battery cover

Detach the cover and install batteries (p. 5).

Transmitter



The transmitter has the following functions.

Function	Explanation
When inserted in the guitar	
Wireless	When you play the guitar, the sound is heard wirelessly from the KATANA-AIR.
Wake up on	If the power is on, and no vibrations are detected for a certain length of time, the unit automatically enters standby mode. In standby mode, if the transmitter plugged into the guitar detects vibration, the power turns on automatically (p. 5).
When inserted in the TRANSMITTER IN jack	
AUTO BATTERY CHARGE	The transmitter is automatically charged.
AUTO WIRELESS CONNECTION	To ensure the most stable connection between the KATANA-AIR and the transmitter, nearby wireless usage in the 2.4 GHz band is detected for ten seconds, and adjustments are made automatically.

By inserting the transmitter in the TRANSMITTER IN jack before plugging it into your guitar, you can charge the transmitter and also obtain a stable wireless connection.

16 DC IN 5 V port (USB Micro-B type)

You can use a commercially available USB cable to charge the transmitter instead of inserting the transmitter in the KATANA-AIR's TRANSMITTER IN jack.

NOTE

Don't charge the transmitter from the DC IN 5 V port while performing with the transmitter inserted in the guitar.

17 Input plug/Power button

When you insert the transmitter into your guitar, the transmitter automatically powers-on.

NOTE

If you insert the transmitter into a guitar whose electrical specifications differ from those of a standard guitar, the transmitter might not power-on. For details, refer to the BOSS website's KATANA-AIR support page.

18 BATTERY indicator

Indicates the status of the transmitter's battery and the wireless connection status.

Status	Indicator	Explanation
When inserted in the guitar		
Remaining battery amount	Lit green	Sufficient capacity remains.
	Lit orange	Capacity is becoming low.
	Lit red	Little capacity remains. Charge the battery.
When inserted in the TRANSMITTER IN jack		
AUTO WIRELESS CONNECTION	Blinking orange	To ensure the most stable connection between the KATANA-AIR and the transmitter, nearby wireless usage in the 2.4 GHz band is detected for ten seconds, and adjustments are made automatically.
AUTO BATTERY CHARGE	Lit orange	Charging.
	Unlit	Charging is completed. * If you're using the KATANA-AIR on batteries, charging automatically stops when the batteries run low.
Overall	Rapid blinking red	A charging error occurred (p. 10).

From Preparations to Performance

Battery Operation

The KATANA-AIR can be powered with eight AA batteries (sold separately).

* If you handle batteries improperly, you risk explosion and fluid leakage. Make sure that you carefully observe all of the items related to batteries that are listed in "USING THE UNIT SAFELY" and "IMPORTANT NOTES" (the leaflet "USING THE UNIT SAFELY" and the Owner's Manual (p. 11)).

Installing Batteries

This KATANA-AIR can be used with alkaline batteries or rechargeable Ni-MH batteries. The operating time will depend on the characteristics of the batteries.

1. Turn the KATANA-AIR over.

* When turning the unit over, be careful so as to protect the buttons and knobs from damage. Also, handle the unit carefully; do not drop it.

2. Remove the battery cover.

3. Insert the batteries, taking care to orient them as shown in the illustration.



AC Adaptor Operation

Use only the AC adaptor included with the KATANA-AIR. Use of other AC adaptors may damage the amp or result in other problems.

Turning the Power On/Off

1. Turn the [MASTER] knob and the [VOLUME] knob of the KATANA-AIR to 0.
2. Minimize the volume of the devices connected to the KATANA-AIR.
3. Turn on the power of the devices that are connected to the INPUT jack and AUX IN jack of the KATANA-AIR.
4. Turn on the power of the KATANA-AIR.
5. Turn on the power of the device that is connected to the  (PHONES)/REC OUT jack.
6. Insert the transmitter into the TRANSMITTER IN jack.
The wireless status is detected automatically.
7. When the BATTERY indicator stops blinking orange, plug the transmitter into your guitar.

When turning the power off, turn the volume to 0 for all devices that are connected to the KATANA-AIR and then turn off their power; finally, turn off the power of the KATANA-AIR.

Automatically Turning On from Standby Mode (Wake Up On)

When the KATANA-AIR and the transmitter are both in standby mode (p. 2, p. 4), and the transmitter detects vibration (for example, because you picked up the guitar), both will automatically power-on (wake up on).

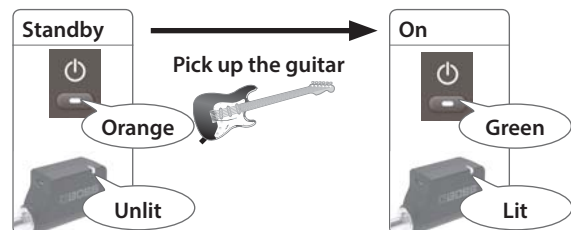

English

日本語

Deutsch

Français

Italiano

Español

Português

Nederlands

Using the Effects

The KATANA amp lets you switch between various types of effect by using the buttons and knobs. You can use three types of effect simultaneously.



Effects assigned to each knob when the unit is shipped

Knob	Color of the button	BST (BOOSTER)	MOD
	Green	BLUES DRIVE	CHORUS
	Red	OVERDRIVE	FLANGER
	Orange	DISTORTION	PHASER

Knob	Color of the button	DELAY	FX
	Green	DIGITAL DELAY	TREMOLO
	Red	ANALOG DELAY	T.WAH
	Orange	TAPE ECHO	OCTAVE

Knob	Color of the button	REVERB
	Green	PLATE REVERB
	Red	SPRING REVERB
	Orange	HALL REVERB

This table shows the effects when the [PANEL] button is on. Use BOSS Tone Studio to see the effects that are assigned when the [CH A] or [CH B] buttons are pressed.

1. Press the [BST/MOD], [DELAY/FX], or [REVERB] button to select the effect that you want to use.

Each time you press the button, its color changes.



2. Turn the knob to adjust the depth of the effect.

* Either BST or MOD is selected depending on the position of the knob.

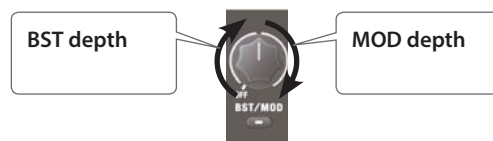

* Either DELAY or FX is selected depending on the position of the knob.



About the Factory-Set Effects

Effect	Explanation
BST	
BLUES DRIVE	A crunch sound like the BOSS BD-2, creating distortion that faithfully reproduces the nuances of your picking.
OVERDRIVE	An overdrive sound like the BOSS OD-1, producing sweet and mild distortion.
DISTORTION	A standard and highly usable distortion sound.
MOD	
CHORUS	An effect that adds a slightly modulated sound to the direct signal, creating beautiful spaciousness and depth.
FLANGER	Produces a flanging effect which applies modulation that is reminiscent of a jet airplane.
PHASER	Produces a phasing effect which applies a sense of rotation to the sound by adding a slightly phase-shifted sound to the direct signal.
DELAY	
DIGITAL DELAY	A clear digital delay sound.
ANALOG DELAY	A mild analog delay sound.
TAPE ECHO	A sound with the distinctive modulation of a tape echo unit.
FX	
TREMOLO	An effect that cyclically modulates the volume.
T.WAH	A wah effect that modulates a filter according to the volume of the guitar, producing a wah effect.
OCTAVE	Adds a sound one octave lower than the input, generating a sense of low-frequency solidity.

Effect	Explanation
REVERB	
PLATE REVERB	Simulates a plate reverb (a reverb unit that uses the vibration of a metal plate), providing a metallic resonance with an extended high-frequency range.
SPRING REVERB	Simulates the spring reverb unit built into some guitar amps.
HALL REVERB	Simulates the reverberation of a concert hall.

Controlling the KATANA-AIR from a smartphone or tablet

By using BOSS Tone Studio, you can edit the effects of the KATANA-AIR from a mobile device such as a smartphone or tablet (subsequently referred to as "mobile device").

You can download dedicated effects from BOSS Tone Central (<http://bosstonecentral.com/>).

You can also back up the effects and internal settings, or restore the settings that you previously backed-up.

Apps for iOS and Android are available. You can install these on your mobile device from the App Store or Google Play.

English

日本語

Deutsch

Français

Italiano

Español

Português

Nederlands

Listening to Sound via Wireless Connection with a Mobile Device

Bluetooth® Audio

By wirelessly connecting the KATANA-AIR to a mobile device that's equipped with Bluetooth audio functionality, you can do the following things.

- You can use the speakers of this unit to listen to music or music videos played on your mobile device.

Registering a Mobile Device (Pairing)

"Pairing" is the procedure by which the mobile device that you want to use is registered on this unit (the two devices recognize each other).

Make settings so that music data saved on the mobile device can be played wirelessly via this unit.

MEMO

The following explanation of the procedure is only one example. For details, refer to the owner's manual of your mobile device.

1. Turn on the power of the KATANA-AIR.
2. Place the mobile device that you want to connect nearby the KATANA-AIR.
3. Long-press the KATANA-AIR's [Bluetooth] button.
* The Bluetooth indicator blinks, and the sound is muted.

4. Turn on the Bluetooth function of the mobile device.

MEMO

The explanation here uses the iPhone as an example. For details, refer to the owner's manual of your mobile device.



5. Tap "KATANA-AIR Audio" that is shown in the Bluetooth device screen of your mobile device.

This unit is paired with the mobile device. When pairing succeeds, "KATANA-AIR Audio" is added to the list of "Paired Devices" on your mobile device.

Connecting an Already-Paired Mobile Device

1. With the KATANA-AIR's [Bluetooth] indicator off, press the [Bluetooth] button.

* The Bluetooth indicator blinks, and the sound is muted.

2. Turn on the Bluetooth function of the mobile device.

MEMO

- If you were unable to establish a connection using the procedure above, tap "KATANA-AIR Audio" that is displayed in the Bluetooth device screen of the mobile device.
- To disconnect, press the KATANA-AIR's [Bluetooth] button to make the Bluetooth indicator go dark, or turn off the mobile device's Bluetooth function.

Adjusting the Volume

1. Adjust the volume on the mobile device.

Adjust the volume of Bluetooth audio.

2. Turn the KATANA-AIR's [MASTER] knob.

The [MASTER] knob adjusts the volume of both the Bluetooth audio and the guitar. When you turn the [MASTER] knob, the volume of the Bluetooth audio and the volume of the guitar will both change.

Controlling the KATANA-AIR from a Mobile Device App

You can use the BOSS Tone Studio app to edit sounds and manage the sound library.

For details on BOSS TONE STUDIO, refer to the BOSS website.

<https://www.boss.info/>

Connecting to the App

Here's how to make settings in order to use an app on your mobile device.

1. Turn on the power of the KATANA-AIR.
2. Place the mobile device that you want to connect nearby this unit.

3. Turn on the Bluetooth function of the mobile device.

MEMO

The explanation here uses the iPhone as an example. For details, refer to the owner's manual of your mobile device.



4. In the app, establish a connection with the KATANA-AIR.

NOTE

Do not tap the "KATANA-AIR MIDI" that is shown in the Bluetooth settings of the mobile device.

Disabling the Bluetooth Functionality

If you want to disconnect the Bluetooth connection between the KATANA-AIR and your mobile device, disable the Bluetooth functionality.

1. Press the KATANA-AIR's [Bluetooth] button.

The Bluetooth indicator goes dark.

Restoring the Factory Settings

Here's how the settings stored in the KATANA-AIR can be returned to their factory-set condition (factory reset).

1. While holding down the [PANEL] button, turn the power on.

Each of the EFFECTS buttons continues blinking consecutively from the left. When the blinking stops, all of the KATANA's settings return to the factory-set state.



* It takes approximately 30 seconds for the factory reset to be completed. Don't turn off the power while the factory reset is in progress.

Note when using an already-paired iOS device

After executing a factory reset, you'll need to perform the following operations.

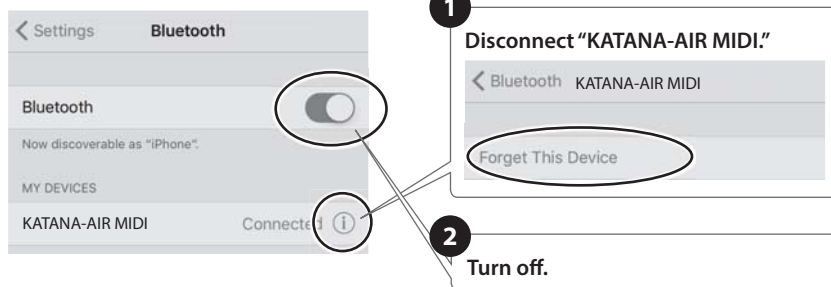

For details, refer to the owner's manual of your iOS device.

Block Diagram

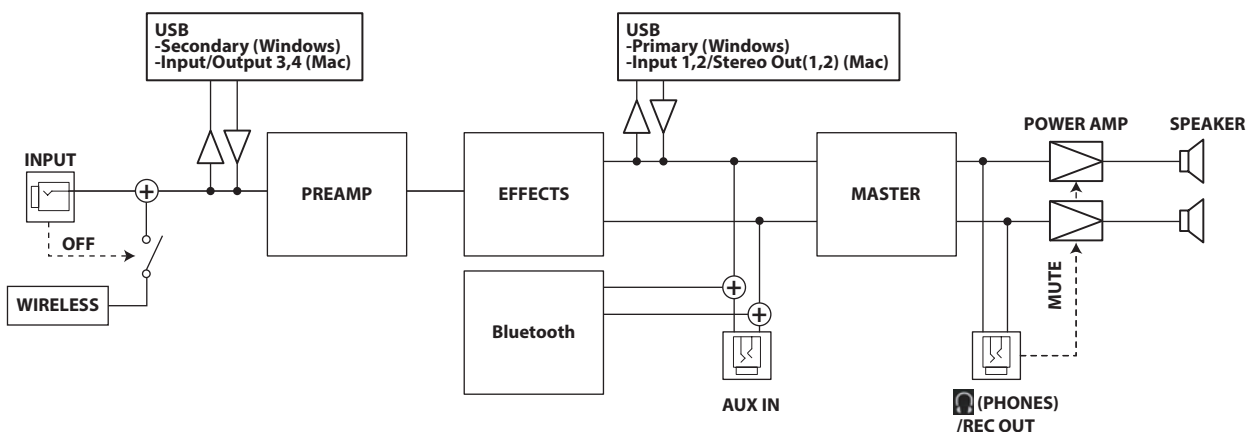

For the USA

FEDERAL COMMUNICATIONS COMMISSION RADIO FREQUENCY INTERFERENCE STATEMENT

This equipment has been tested and found to comply with the limits for a Class B digital device, pursuant to Part 15 of the FCC Rules. These limits are designed to provide reasonable protection against harmful interference in a residential installation. This equipment generates, uses, and can radiate radio frequency energy and, if not installed and used in accordance with the instructions, may cause harmful interference to radio communications. However, there is no guarantee that interference will not occur in a particular installation. If this equipment does cause harmful interference to radio or television reception, which can be determined by turning the equipment off and on, the user is encouraged to try to correct the interference by one or more of the following measures:

- Reorient or relocate the receiving antenna.
- Increase the separation between the equipment and receiver.
- Connect the equipment into an outlet on a circuit different from that to which the receiver is connected.
- Consult the dealer or an experienced radio/TV technician for help.

This device complies with Part 15 of the FCC Rules. Operation is subject to the following two conditions:
(1) this device may not cause harmful interference, and
(2) this device must accept any interference received, including interference that may cause undesired operation.

This equipment requires shielded interface cables in order to meet FCC class B limit.
Any unauthorized changes or modifications not expressly approved by the party responsible for compliance could void the user's authority to operate the equipment.

For Canada

CAN ICES-3 (B)/NMB-3 (B)

For Korea

사용자 안내문

기종별	사용자 안내문
B 급 기기 (가정용 방송통신기자재)	이 기기는 가정용(B 급) 전자파적합기기로서 주로 가정에서 사용하는 것을 목적으로 하며, 모든 지역에서 사용할 수 있습니다.

For C.A. US (Proposition 65)

WARNING

This product contains chemicals known to cause cancer, birth defects and other reproductive harm, including lead.



お問い合わせの窓口

● 製品に関するお問い合わせ先

ローランドお客様相談センター **050-3101-2555**

電話受付時間： 月曜日～金曜日 10:00～17:00 (弊社規定の休日を除く)

※IP電話からおかけになって繋がらない場合には、お手数ですが、電話番号の前に"0000"
(ゼロ4回)をつけてNTTの一般回線からおかけいただくか、携帯電話をご利用ください。

※上記窓口の名称、電話番号等は、予告なく変更することがありますのでご了承ください。

● 最新サポート情報

製品情報、イベント／キャンペーン情報、サポートに関する情報など

ローランド・ホームページ <http://www.roland.co.jp/>

ボス・ホームページ <http://jp.boss.info/>