









USING THE UNIT SAFELY

INSTRUCTIONS FOR THE PREVENTION OF FIRE, ELECTRIC SHOCK, OR INJURY TO PERSONS

About WARNING and CAUTION Notices









 WARNING	Used for instructions intended to alert the user to the risk of death or severe injury should the unit be used improperly.
 CAUTION	Used for instructions intended to alert the user to the risk of injury or material damage should the unit be used improperly. * Material damage refers to damage or other adverse effects caused with respect to the home and all its furnishings, as well to domestic animals or pets.

About the Symbols





	The  symbol alerts the user to important instructions or warnings. The specific meaning of the symbol is determined by the design contained within the triangle. In the case of the symbol at left, it is used for general cautions, warnings, or alerts to danger.
	The  symbol alerts the user to items that must never be carried out (are forbidden). The specific thing that must not be done is indicated by the design contained within the circle. In the case of the symbol at left, it means that the unit must never be disassembled.
	The  symbol alerts the user to things that must be carried out. The specific thing that must be done is indicated by the design contained within the circle. In the case of the symbol at left, it means that the power-cord plug must be unplugged from the outlet.

ALWAYS OBSERVE THE FOLLOWING









WARNING

- Before using this unit, make sure to read the instructions below, and the Owner's Manual. 
- Do not open or perform any internal modifications on the unit. 
- Do not attempt to repair the unit, or replace parts within it (except when this manual provides specific instructions directing you to do so). Refer all servicing to your retailer, the nearest Roland Service Center, or an authorized Roland distributor, as listed on the "Information" page. 
- Never use or store the unit in places that are:
 - Subject to temperature extremes (e.g., direct sunlight in an enclosed vehicle, near a heating duct, on top of heat-generating equipment); or are 
 - Damp (e.g., baths, washrooms, on wet floors); or are 
 - Humid; or are
 - Exposed to rain; or are
 - Dusty; or are
 - Subject to high levels of vibration.
- Make sure you always have the unit placed so it is level and sure to remain stable. Never place it on stands that could wobble, or on inclined surfaces. 
- The unit should be connected to a power supply only of the type described in the operating instructions, or as marked on the rear of unit. 
- Use only the attached power-supply cord. Also, the supplied power cord must not be used with any other device. 



WARNING







- Do not excessively twist or bend the power cord, nor place heavy objects on it. Doing so can damage the cord, producing severed elements and short circuits. Damaged cords are fire and shock hazards! 
- This unit, either alone or in combination with an amplifier and headphones or speakers, may be capable of producing sound levels that could cause permanent hearing loss. Do not operate for a long period of time at a high volume level, or at a level that is uncomfortable. If you experience any hearing loss or ringing in the ears, you should immediately stop using the unit, and consult an audiologist. 
- Do not allow any objects (e.g., flammable material, coins, pins); or liquids of any kind (water, soft drinks, etc.) to penetrate the unit. 

- Immediately turn the power off, remove the power cord from the outlet, and request servicing by your retailer, the nearest Roland Service Center, or an authorized Roland distributor, as listed on the "Information" page when:
 - The power-supply cord, or the plug has been damaged; or
 - If smoke or unusual odor occurs
 - Objects have fallen into, or liquid has been spilled onto the unit; or
 - The unit has been exposed to rain (or otherwise has become wet); or
 - The unit does not appear to operate normally or exhibits a marked change in performance.

WARNING

- In households with small children, an adult should provide supervision until the child is capable of following all the rules essential for the safe operation of the unit. 
- Protect the unit from strong impact. (Do not drop it!) 
- Do not force the unit's power-supply cord to share an outlet with an unreasonable number of other devices. Be especially careful when using extension cords—the total power used by all devices you have connected to the extension cord's outlet must never exceed the power rating (watts/amperes) for the extension cord. Excessive loads can cause the insulation on the cord to heat up and eventually melt through. 
- Before using the unit in a foreign country, consult with your retailer, the nearest Roland Service Center, or an authorized Roland distributor, as listed on the "Information" page. 
- Batteries must never be recharged, heated, taken apart, or thrown into fire or water. 

- DO NOT play a CD-ROM disc on a conventional audio CD player. The resulting sound may be of a level that could cause permanent hearing loss. Damage to speakers or other system components may result. 
- Do not put anything that contains water (e.g., flower vases) on this unit. Also, avoid the use of insecticides, perfumes, alcohol, nail polish, spray cans, etc., near the unit. Swiftly wipe away any liquid that spills on the unit using a dry, soft cloth. 

CAUTION

- The unit should be located so that its location or position does not interfere with its proper ventilation. 
- Always grasp only the plug on the power-supply cord when plugging into, or unplugging from, an outlet or this unit. 

- At regular intervals, you should unplug the power plug and clean it by using a dry cloth to wipe all dust and other accumulations away from its prongs. Also, disconnect the power plug from the power outlet whenever the unit is to remain unused for an extended period of time. Any accumulation of dust between the power plug and the power outlet can result in poor insulation and lead to fire. 
- Try to prevent cords and cables from becoming entangled. Also, all cords and cables should be placed so they are out of the reach of children. 
- Never climb on top of, nor place heavy objects on the unit. 
- Never handle the power cord or its plugs with wet hands when plugging into, or unplugging from, an outlet or this unit. 
- If you need to move the instrument, take note of the precautions listed below. At least two persons are required to safely lift and move the unit. It should be handled carefully, all the while keeping it level. Make sure to have a firm grip, to protect yourself from injury and the instrument from damage. 
 - Check to make sure the screw securing the unit to the stand have not become loose. Fasten them again securely whenever you notice any loosening.
 - Disconnect the power cord.
 - Disconnect all cords coming from external devices.
 - Raise the adjusters on the stand (p. 18).
 - Close the lid.
 - Fold down the music rest.
- Before cleaning the unit, turn off the power and unplug the power cord from the outlet (p. 17). 
- Whenever you suspect the possibility of lightning in your area, pull the plug on the power cord out of the outlet. 

 **CAUTION**

- If used improperly, batteries may explode or leak and cause damage or injury. In the interest of safety, please read and observe the following precautions (p. 17).



- Carefully follow the installation instructions for batteries, and make sure you observe the correct polarity.
- Avoid using new batteries together with used ones. In addition, avoid mixing different types of batteries.
- Remove the batteries whenever the unit is to remain unused for an extended period of time.
- If a battery has leaked, use a soft piece of cloth or paper towel to wipe all remnants of the discharge from the battery compartment. Then install new batteries. To avoid inflammation of the skin, make sure that none of the battery discharge gets onto your hands or skin. Exercise the utmost caution so that none of the discharge gets near your eyes. Immediately rinse the affected area with running water if any of the discharge has entered the eyes.
- Never keep batteries together with metallic objects such as ballpoint pens, necklaces, hairpins, etc.

-
- Used batteries must be disposed of in compliance with whatever regulations for their safe disposal that may be observed in the region in which you live.



- The power-supply cord, or the plug has been damaged; or
- If smoke or unusual odor occurs
- Objects have fallen into, or liquid has been spilled onto the unit; or
- The unit has been exposed to rain (or otherwise has become wet); or
- The unit does not appear to operate normally or exhibits a marked change in performance.

-
- Be careful when opening/closing the lid so you do not get your fingers pinched (p. 17). Adult supervision is recommended whenever small children use the unit.



-
- Always keep the following parts including with the RG-7 and small components that may be removed out of the reach of small children to avoid accidental ingestion of these parts.



Included Parts

- External memory anti-theft lock securing screw

Removable parts

- Screws fastening the stand
 - Screws fastening music rest
 - the thumbscrew fastening the headphone hook
-

IMPORTANT NOTES

In addition to the items listed under “IMPORTANT SAFETY INSTRUCTIONS” and “USING THE UNIT SAFELY” on pages 2 and 3, please read and observe the following:

Power Supply

- Do not connect this unit to same electrical outlet that is being used by an electrical appliance that is controlled by an inverter (such as a refrigerator, washing machine, microwave oven, or air conditioner), or that contains a motor. Depending on the way in which the electrical appliance is used, power supply noise may cause this unit to malfunction or may produce audible noise. If it is not practical to use a separate electrical outlet, connect a power supply noise filter between this unit and the electrical outlet.
- Batteries are supplied with the unit. The life of these batteries may be limited, however, since their primary purpose was to enable testing.
- Before connecting this unit to other devices, turn off the power to all units. This will help prevent malfunctions and/or damage to speakers or other devices.
- Although the LCD and LEDs are switched off when the POWER switch is switched off, this does not mean that the unit has been completely disconnected from the source of power. If you need to turn off the power completely, first turn off the POWER switch, then unplug the power cord from the power outlet. For this reason, the outlet into which you choose to connect the power cord’s plug should be one that is within easy reach and readily accessible.

Placement

- Using the unit near power amplifiers (or other equipment containing large power transformers) may induce hum. To alleviate the problem, change the orientation of this unit; or move it farther away from the source of interference.
- This device may interfere with radio and television reception. Do not use this device in the vicinity of such receivers.
- Noise may be produced if wireless communications devices, such as cell phones, are operated in the vicinity of this unit. Such noise could occur when receiving or initiating a call, or while conversing. Should you experience such problems, you should relocate such wireless devices so they are at a greater distance from this unit, or switch them off.
- Do not expose the unit to direct sunlight, place it near devices that radiate heat, leave it inside an enclosed vehicle, or otherwise subject it to temperature extremes. Also, do not allow lighting devices that normally are used while their light source is very close to the unit (such as a piano light), or powerful spotlights to shine upon the same area of the unit for extended periods of time. Excessive heat can deform or discolor the unit.
- When moved from one location to another where the temperature and/or humidity is very different, water droplets (condensation) may form inside the unit. Damage or malfunction may result if you attempt to use the unit in this condition. Therefore, before using the unit, you must allow it to stand for several hours, until the condensation has completely evaporated.
- Do not allow rubber, vinyl, or similar materials to remain on the unit for long periods of time. Such objects can discolor or otherwise harmfully affect the finish.
- Do not allow objects to remain on top of the keyboard. This can be the cause of malfunction, such as keys ceasing to produce sound.

- Do not paste stickers, decals, or the like to this instrument. Peeling such matter off the instrument may damage the exterior finish.

Maintenance

- To clean the unit, use a dry, soft cloth; or one that is slightly dampened. Try to wipe the entire surface using an equal amount of strength, moving the cloth along with the grain of the wood. Rubbing too hard in the same area can damage the finish.
- Never use benzine, thinners, alcohol or solvents of any kind, to avoid the possibility of discoloration and/or deformation.
- The pedals of this unit are made of brass. Brass eventually darkens as the result of the natural oxidization process. If the brass becomes tarnished, polish it using commercially available metal polisher.

Repairs and Data

- Please be aware that all data contained in the unit’s memory may be lost when the unit is sent for repairs. Important data should always be backed up on an external memory, or written down on paper (when possible). During repairs, due care is taken to avoid the loss of data. However, in certain cases (such as when circuitry related to memory itself is out of order), we regret that it may not be possible to restore the data, and Roland assumes no liability concerning such loss of data.

Additional Precautions

- Please be aware that the contents of memory can be irretrievably lost as a result of a malfunction, or the improper operation of the unit. To protect yourself against the risk of losing important data, we recommend that you periodically save a backup copy of important data you have stored in the unit’s memory on an external memory.
- Unfortunately, it may be impossible to restore the contents of data that was stored on an external memory once it has been lost. Roland Corporation assumes no liability concerning such loss of data.
- Use a reasonable amount of care when using the unit’s buttons, sliders, or other controls; and when using its jacks and connectors. Rough handling can lead to malfunctions.
- Never strike or apply strong pressure to the display.
- When connecting / disconnecting all cables, grasp the connector itself—never pull on the cable. This way you will avoid causing shorts, or damage to the cable’s internal elements.
- A small amount of heat will radiate from the unit during normal operation.
- To avoid disturbing your neighbors, try to keep the unit’s volume at reasonable levels. You may prefer to use headphones, so you do not need to be concerned about those around you (especially when it is late at night).
- When you need to transport the unit, pack it in shock-absorbent material. Transporting the unit without doing so can cause it to become scratched or damaged, and could lead to malfunction.

- Do not apply undue force to the music rest while it is in use.
- Use only the specified expression pedal (EV-7/5; sold separately). By connecting any other expression pedals, you risk causing malfunction and/or damage to the unit.
- Use a cable from Roland to make the connection. If using some other make of connection cable, please note the following precautions.
 - Some connection cables contain resistors. Do not use cables that incorporate resistors for connecting to this unit. The use of such cables can cause the sound level to be extremely low, or impossible to hear. For information on cable specifications, contact the manufacturer of the cable.
- Before opening or closing the keyboard lid, always make sure that no pets or other small animals are located on top of the instrument (in particular, they should be kept away from the keyboard and its lid). Otherwise, due to the structural design of this instrument, small pets or other animals could end up getting trapped inside it. If such a situation is encountered, you must immediately switch off the power and disconnect the power cord from the outlet. You should then consult with the retailer from whom the instrument was purchased, or contact the nearest Roland Service Center.

Handling Floppy Disks

- Floppy disks contain a plastic disk with a thin coating of magnetic storage medium. Microscopic precision is required to enable storage of large amounts of data on such a small surface area. To preserve their integrity, please observe the following when handling floppy disks:
 - Never touch the magnetic medium inside the disk.
 - Do not use or store floppy disks in dirty or dusty areas.
 - Do not subject floppy disks to temperature extremes (e.g., direct sunlight in an enclosed vehicle). Recommended temperature range: 10 to 50°C (50 to 122°F).
 - Do not expose floppy disks to strong magnetic fields, such as those generated by loudspeakers.
- Floppy disks have a “write protect” tab which can protect the disk from accidental erasure. It is recommended that the tab be kept in the PROTECT position, and moved to the WRITE position only when you wish to write new data onto the disk.

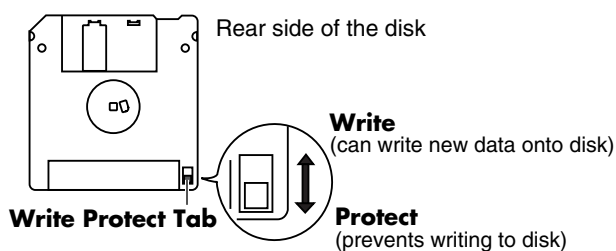

- The identification label should be firmly affixed to the disk. Should the label come loose while the disk is in the drive, it may be difficult to remove the disk.
- Store all disks in a safe place to avoid damaging them, and to protect them from dust, dirt, and other hazards. By using a dirty or dust-ridden disk, you risk damaging the disk, as well as causing the disk drive to malfunction.
- Disks containing performance data for this unit should always be locked (have their write protect tab slid to the “Protect” position) before you insert them into the drive on some other unit (except the PR-300, or a product in the HP-G, HPi, MT, KR, or Atelier families), or into a computer’s drive. Otherwise (if the write protect tab remains in the “Write” position), when you perform any disk operations using the other device’s disk drive (such as checking the contents of the disk, or loading data), you risk rendering the disk unreadable by this unit’s disk drive.

Handling CD-ROMs

- Avoid touching or scratching the shiny underside (encoded surface) of the disc. Damaged or dirty CD-ROM discs may not be read properly. Keep your discs clean using a commercially available CD cleaner.

Before Using External Memory

Using External Memory

- Never touch the terminals of the External memory. Also, avoid getting the terminals dirty.
- External memories are constructed using precision components; handle the cards carefully, paying particular note to the following.
 - To prevent damage to the cards from static electricity, be sure to discharge any static electricity from your own body before handling the cards.
 - Do not touch or allow metal to come into contact with the contact portion of the cards.
 - Do not bend, drop, or subject cards to strong shock or vibration.
 - Do not keep cards in direct sunlight, in closed vehicles, or other such locations (storage temperature: 0 to 50° C).
 - Do not allow cards to become wet.
 - Do not disassemble or modify the cards.
- When connecting external memory, make sure to press it until it is fully inserted.
- Insert the external memory in the External Memory port evenly and without undue force. Forcing the external memory may damage the External Memory port.
- Do not insert any object other than the external memory (e.g., wires, coins, other types of disks, etc.) in the External Memory port. This may damage the External Memory port.
- Do not subject the External Memory port cover or connected External memory to excessive stress.
- Close the external memory cover when using the External memory for extended periods

* GS () is a registered trademark of Roland Corporation.

* XG lite () is a registered trademark of Yamaha Corporation.

* All product names mentioned in this document are trademarks or registered trademarks of their respective owners.

Introduction

Thank you, and congratulations on your choice of the Roland KR Intelligent Piano.

While the KR Intelligent Piano certainly allows you to achieve authentic piano performances, it also features easy-to-use Automatic Accompaniment and numerous other useful functions. In order to enjoy reliable performance of your new keyboard for many years to come, please take the time to read through this manual in its entirety.

Main Features

○ **Lusciously Resounding, Richly Expressive Piano Sound**

The KR107 reproduces the rich tones of a high-quality grand piano, from the sounds of the hammers as they strike the strings to the sounds made as the keys are released. 128-voice polyphony ensures full responsiveness, even with heavy use of the pedals.

What's more, The "Piano Designer" feature allows you to create your own favorite piano tones.

○ **True Grand Piano Feel**

The KR107 features Roland's Progressive Hammer Action keyboard, which reproduces the feel of a grand piano, with a firm, weighty touch in the lower registers and a lighter response in the upper registers. This keyboard also faithfully reproduces the distinctive "click" that's produced when a grand piano's keys are played (Escapement function).

In addition to the ability of adjusting the key weight, a "Hammer Response" function, which reproduces the subtle action of the hammers, is also incorporated, so there are two key-touch controls that come into play when determining the precise character of the keyboard. Additionally, the instrument's pedals are firm and responsive, lending your performances fuller and more detailed expressiveness.

○ **Accomplish Tasks Easily with the Main Buttons**

Almost all of the KR's common functions, including playing back songs, displaying notations, running the automatic accompaniment, selecting tones, and so on can be accomplished using the Main buttons to the left of the screen.

○ **A Wealth of Practice Features to Foster Musical Growth**

Use the "Visual Lesson" feature for enjoyable practice and steady improvement.

You can use this function to score the results of your performances and find out which notes have been played differently than those indicated in the notation.

The KR also scrolls the notation automatically as you play, making your practices even more convenient.

○ **Connector Allows Enlarged Display of Music and Lyrics**

The KR107 is equipped with a connector for use with televisions and other external displays.

Connecting a large screen to the KR107 allows you to display a greater number of measures at the same time.

Notes are colored for easy viewing, a feature that is useful for personal practice as well as in lessons.

○ **Easy-To-Use "Music Assistant" Automatic Accompaniment Feature**

You can select from an amazing 500 settings to get automatic accompaniment that perfectly matches the song you are playing.

Each song's Music Assistant settings are shown in a manner that is easy to grasp, so playing along with the changes in the accompaniment is a snap.

For easy enjoyment of Music Assistant, the KR107 also includes songs that you can perform while reading the chord charts.

○ **Color Display for Easy Operation**

The KR107 features a color screen touch panel with rich graphics to make viewing easier. Operations can be carried out easily, just by touching the screen.

○ **Utilizes External Memory--the New Media**

You can save song data created on the KR107 to External memory (sold separately). Extremely portable, high-capacity external memory also connects easily to computers, allowing song data to be transferred easily. Taking further advantage of the high-capacity memory, you can also play back audio files with the KR107.

How To Use This Manual

The KR Owner's Manual consists of two volumes, **Quick Start**, **Owner's Manual**, and the **USB Install Guide**.

Please start out by reading "Before You Start Playing" (p. 16) in the **Owner's Manual** (this volume). This explains how to connect the KR's power cord and how to turn on the instrument's power.

After turning on the KR's power, please continue by reading **Quick Start**.

By trying out the various procedures while reading the **Quick Start**, you can easily learn how to play the KR and make use of its major functions (especially procedures that involve use of the "main buttons").

The **Owner's Manual** describes procedures, from basic operation to procedures for special applications (for example, using the KR as an accompanist and creating songs), that will help you master the KR's many performance functions.

When connecting a computer to the USB port, be sure to read the computer connection guide. This describes the procedure for installing the driver needed to connect via USB.

- * *For more on system requirements, refer to the "USB Installation Guide." However, note that the KR107 is not compatible with Mac OS 9.*

■ Conventions Used in This Manual

This manual uses the following conventions in the interest of simpler, more concise instructions.

- Button names are enclosed in square brackets "[]", as in One Touch Program [Piano] button.
- For easier readability, some screens and colors used here may differ in part from actual screens and colors.
- On screen text is enclosed in angled brackets "< >", as in <Exit>.
- The act of lightly contacting the Touch Screen with your finger is called "touching."
- An asterisk (*) or a **NOTE** at the beginning of a paragraph indicates a note or precaution. These should not be ignored.
- (p. **) refers to pages within the manual.

Contents

USING THE UNIT SAFELY.....	3
IMPORTANT NOTES.....	6
Introduction	8
Main Features.....	8
How To Use This Manual	9
Conventions Used in This Manual.....	9
Panel Descriptions.....	10
Balance.....	10
Performance Pads	10
Rhythm Partner.....	10
Record/Playback	11
Rear Panel.....	12
Bottom Panel	12
Bottom Panel (Front Left)	12
Bottom Panel (Front Right).....	12
Before You Start Playing	18
Connect the Pedal Cable.....	18
Connect the Speaker Cable.....	18
Connect the Power Cord	18
Setting Up the Music Rest.....	18
Folding Down the Music Rest.....	18
Using the Music Holders	18
Removing the Music Rest.....	18
Installing Batteries in the Remote Control.....	19
Opening/Closing the Lid.....	19
Turning the Power On and Off.....	19
About the Pedals.....	20
Adjusting the Sound's Volume and Brilliance	20
Connecting Headphones	20
Using the Headphone Hook.....	21
Connecting a Microphone	21
About the Touch Screen	21
Adjusting the Contrast of the Screen	21
Main Screens	22
Piano Screen.....	22
Basic Screen.....	22
Using the Main Icons.....	22
The [Option] Button and The [Exit] Button	22
The Scroll Bar and The Page Icon.....	22
Chapter 1 Performance.....	23
Playing the Keyboard Like a Piano (One-Touch Piano).....	23
Performing with a Variety of Tones (Tone Buttons)	24
Playing Percussion Instruments or Sound Effects	25
Using Keywords to Search for Tones (Tone Search)	26
Performing with Multiple Sounds Layered Together (Layer)....	27
Playing Different Tones with the Left and Right Hands (Split) ..	28
Shifting the Keyboard Pitch in Octave Steps (Octave Shift) ..	29
Adding Reverberation to the Sound (Reverb).....	30
Adding Three-Dimensional Breadth to the Sounds You Play (Advanced 3D).....	32
Adding Liveliness to the Sound (Dynamic Emphasis)	34
Adjusting the Sound to Achieve the Preferred Tone Quality (Equalizer).....	35
Applying Effects to the Sound (Effects)	37
Adding Effects to Mic Vocals (Vocal Effect).....	38
Enjoying Karaoke Performances with Music Files	44
Using the Metronome	45
Using the Metronome.....	45
Changing the Metronome Settings.....	46
Chapter 2 Automatic Accompaniment	48
Music Styles and Automatic Accompaniment.....	48
Performing Using Automatic Accompaniment (One-Touch Arranger)	49
About Chords	50
Playing Chords with Simple Fingering (Chord Intelligence).....	50
Viewing Chord Fingerings (Chord Finder).....	51
Selecting Music Styles (Music Style Buttons)	52
Selecting Music Styles on External Memories	53
Using Keywords to Search for Music Styles (Style Search)	54
Playing Only Music Style Rhythm Patterns	55
Adjusting the Accompaniment Tempo	55
Starting and Stopping the Accompaniment	56
Having the Accompaniment Start Simultaneously When You Play the Keyboard (Sync).....	56
Stopping Automatic Accompaniment	57
Having a Count Sound Play at the End of the Intro (Countdown)	58
Modifying an Accompaniment.....	59
Changing the Accompaniment Pattern (Fill In Buttons).....	59
Changing Accompaniment Patterns in the Screen	60
Changing the Instrumental Makeup of Music Styles (Style Orchestrator).....	60
Adding Harmony to the Right-Hand Part (Melody Intelligence)	61
Playing Sounds in the Left Hand During a Performance (Lower Tone)	62
Playing the Piano with Accompaniment Added (Piano Style Arranger)	63
Adjusting the Volume Balance for Each Part (Balance).....	64
Changing the Volume Balance between the Accompaniment and the Keyboard (Balance Knob).....	64
Adjusting the Volume Balance for Each Performance Part (Part Balance).....	64
Chapter 3 Song Playback	66
Playing a Song.....	66
Using Keywords to Search for Songs (Song Search).....	69
Registering the Songs You Like (Favorites).....	70
Removing Songs from Favorites.....	71

Contents

Using the Remote Control.....	72	Copying Sets of User Programs on Floppy Disks to the User Memory.....	112
How to Use the Remote Control.....	72	Coping Sets of User Programs Stored in the User Memory to Floppy Disks.....	113
About the Remote Control.....	73	Using the Pedal to Switch User Programs.....	113
Chapter 4 Practice Functions	75	Selecting the Pedal Used for Switching Settings (Pedal Shift).....	113
Displaying the Notation.....	75	Sequential Loading of User Program Sets Stored in External Memory (Load Next).....	113
Touching Notes to Confirm the Sounds (Touch the Notes).....	76	Simultaneously Switching User Program and Transmitting PC Numbers.....	113
Scrolling the Notation Along with the Performances (Auto Sync DigiScore).....	76	Chapter 7 Creating and Editing Songs	115
Making Detailed Settings for the Notation Display.....	77	Multitrack Recording with 16 Parts (16-Track Sequencer).....	115
Saving Notations as Image Data.....	80	The 16-Track Sequencer Screen.....	115
Adjusting the Tempo.....	82	Modifying the Settings of Each Part.....	116
Setting the Tempo by Pressing the Button in Time (Tap Tempo).....	82	Getting the Most Suitable Part Tones for the Musical Genre (Tone Set).....	117
Playing Back at a Fixed Tempo (Tempo Mute).....	83	Recording a Performance.....	117
Match the Tempo Before You Begin Playing (Count).....	84	Changing the Recording Method (Rec Mode).....	118
Muting Some Parts Before Playing (Track Buttons).....	85	Recording While Erasing the Previous Recording (Replace Recording).....	119
Setting Markers for Repeated Practice (Marker).....	86	Layering a Recording Over Previously Recorded Sounds (Mix Recording).....	119
Placing a Marker within a Song.....	86	Repeated Recording at the Same Location (Loop Recording).....	120
Playback from a Marker Location.....	87	Re-Recording Part of Your Performance (Punch-in Recording).....	121
Erasing a Marker.....	87	Composing an Accompaniment By Entering Chords (Chord Sequencer).....	122
Moving a Marker.....	87	Inputting Chords without Playing the Keyboard.....	123
Playing Back the Same Passage Over and Over.....	88	Editing Songs.....	123
Transposing Keyboard Sounds and Songs Played Back (Transpose).....	89	Basic Operation of the Editing Functions.....	123
Chapter 5 Recording and Saving the Performance .	91	Undoing Edits (Undo).....	124
Recording a New Song (New Song).....	92	Copying Measures (Copy).....	124
Recording With Accompaniment.....	94	Correcting Timing Discrepancies (Quantize).....	125
Recording Along with a Song.....	96	Deleting Measures (Delete).....	125
Recording While Selecting the Track Buttons (Redoing Recordings).....	97	Inserting Blank Measures (Insert).....	126
Erasing Recorded Performances.....	98	Transposing Individual Parts (Transpose).....	126
Erasing the Performance on Specific Tracks.....	98	Making Measures Blank (Erase).....	126
Changing How Recording Stops.....	98	Exchanging Parts (Part Exchange).....	127
Recording Songs Starting with Pickups.....	99	Correcting Notes One by One (Note Edit).....	128
Using External Memories.....	100	Modifying the Tone Changes in a Song (PC Edit).....	128
Connecting and Ejecting a External Memory.....	100	Changing the Beat in the Middle of a Song (Beat Map).....	129
Formatting Media (Format).....	101	Changing the Tempo of Recorded Songs.....	129
Saving Songs.....	103	Changing the Tempo Within the Song.....	129
Deleting Saved Songs.....	106	Adjusting the Tempo While Listening to a Song.....	129
Copying Songs on External Memories to Favorites.....	107	Adjusting the Tempo at a Particular Measure.....	130
Copying Songs Saved in Favorites to External Memories...108		Chapter 8 Creating Music Styles	131
Chapter 6 User Program Registration.....	109	Creating Original Styles (User Styles).....	131
Saving Performance Settings (User Program).....	109	Creating New Styles by Combining Internal Music Styles (Style Composer).....	131
Calling Up Saved User Programs.....	110	Creating a Style from a Song You Composed Yourself.....	
Changing the Way User Programs Are Called Up.....	110		
Saving the User Program Sets.....	110		
Loading Saved User Program Sets.....	111		
Deleting Saved User Program Sets.....	112		

(Style Converter)133
 Saving a User Style136
 Deleting Saved User Styles137
 Copying Styles on Floppy Disks to the User Memory138
 Copying Styles Saved in the User Memory to
 Floppy Disks138

Chapter 9 Various Settings139

Changing the Settings for One-Touch Arranger 139
 Procedure 139
 Adjusting the Keyboard Touch (Key Touch)139
 Changing the Keyboard's Split Point (Split Point) 140
 Changing Music Styles Without Changing the Tone or
 Tempo (One Touch Setting) 140
 Changing How Chords Are Played and Specified
 (Arranger Config) 140
 Placing a Marker in the Middle of a Measure142
 Changing the Settings for the Count142
 Other Settings143
 Procedure143
 Changing the Tuning (Tuning)144
 Assigning Functions to Pedals and Performance Pads
 (Pedal Setting/User Functions)145
 Changing the Bend Range (Pedal Setting)147
 Changing Standard Pitch (Master Tune)147
 Changing the Language (Language)147
 Selecting Images To Be Shown on the KR and
 External Displays
 (User Image Display)148
 Changing the Screen Message When the Power Is
 Turned On (Opening Message)148
 Remembering the Settings Even When the Power is
 Turned Off (Memory Backup)149
 Restoring the Factory Settings (Factory Reset)149
 Changing the Functions of the Remote Control's Buttons ..150
 Switching the Remote Sensor On and Off (iR function)151
 Calibrating the Touch Screen (Touch Screen)151
 Selecting the Part to Which the Effect is Added (Effects Part) ..151
 Formatting the User Memory 152
 Automatically Starting the Quick Tour152
 Adjusting the Piano Designer Resonance153
 Disabling Functions Other Than Piano Performance
 (Panel Lock)153
 Detailed Song Playback Settings154
 Changing the Tone Settings When Playing Back Songs
 (Play Mode)154
 Viewing Song Information (Information)154
 Hiding the Lyrics (Lyrics)154
 Changing the Parts Assigned to the Track Buttons
 During SMF Playback (Track Assign)155

Chapter 10 Connecting External Devices156

Connecting an External Display or Television156
 Connecting an External Display156

Connecting a Television157
 Changing the Settings for Showing Images with the
 External Display and the Television (External Display)158
 Connecting Video Equipment (V-LINK)158
 Using the V-LINK function158
 Connecting MIDI Devices159
 Connectors159
 Making the Connections160
 Performing in Ensemble with MIDI Instruments
 (MIDI Ensemble)160
 MIDI Settings161
 Selecting the Transmit Channel (Tx Channel)161
 Disconnecting the Internal Sound Generator and
 Keyboard (Local Control)161
 Sending Tone Change Messages (Program Change/
 Bank Select MSB/Bank Select LSB)162
 Sending Recorded Performance Data to a MIDI Device
 (Composer MIDI Out)162
 Connecting to Audio Equipment163
 Connectors163
 Making the Connections163
 Connecting a Computer164
 Connect to the MIDI Connectors164
 Connect to the USB Connector165
 Making the Settings for the USB Driver165
 Troubleshooting166

Appendices 166

Error Messages170
 Tone List171
 Drum Set List173
 Effects List177
 Music Style List178
 Chord List179
 Internal Song List181
 Parameters Stored to Internal Memory183
 Music Files That the KR Can Use184
 The KR allows you to use the following music files184
 About the KR Sound Generator184
 Main Specifications186
 MIDI Implementation Chart186

Index 187

Panel Descriptions

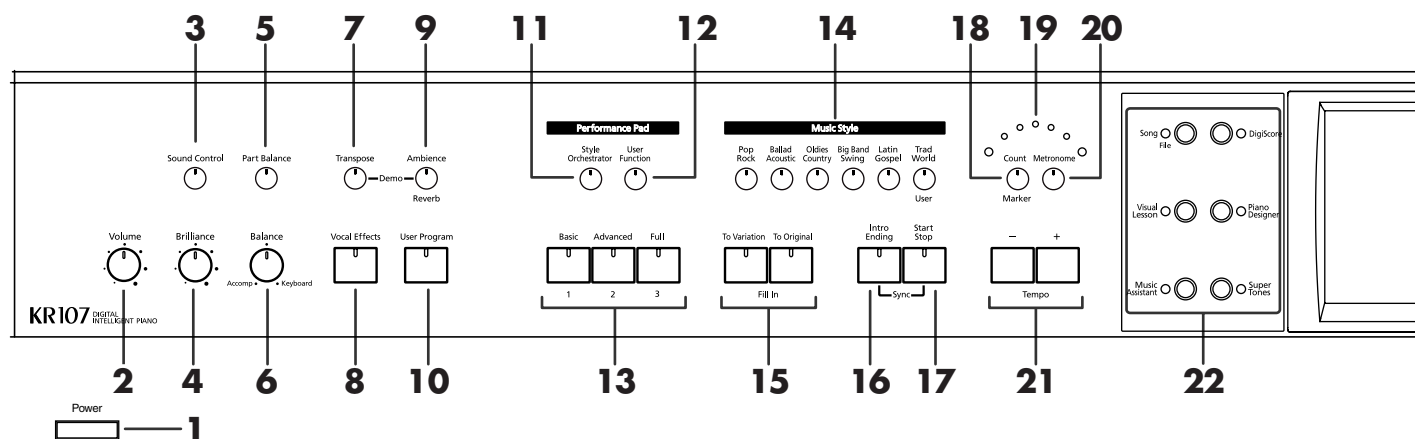

1. [Power] switch

Pressed to switch the power on and off (p. **).

2. [Volume] knob

Adjusts the overall volume (p. **).

3. [Sound Control] button.

Add liveliness to the sound to give it superb clarity and distinctness.

4. [Brilliance] knob

Adjusts the brightness of the sound (p. **).

Balance

5. [Part Balance] button

This adjusts the relative volume levels of each of the performance parts (p. **).

6. [Balance] knob

Changes the volume balance for sounds played with the keyboard and for songs and accompaniments (p. **).

7. [Transpose] button

Transposes the pitch of the keyboard or the song being played (p. **).

8. [Vocal Effect] Button

Applies a variety of effects to vocals from the microphone (p. **).

9. [Ambience/Reverb] button

Adds reverberation to the sound (p. **).
Adds three-dimensional breadth to the sound

10. [User Program] button

Stores the selected functions and states of the buttons (p. **).

Performance Pads

11. [Style Orchestrator] button

This is used to change the arrangement type for automatic accompaniment with the Performance Pads (p. **).

12. [User Function] Button

This is used to assign a variety of functions to the Performance Pads (p. **).

13. [1]-[3] buttons

The operation of each is changed depending on the buttons numbered 11-12.

14. Music Style buttons

Selects a Music Style for automatic accompaniment (p. 62).
Pressing the [User] button selects a User Style that you've made yourself or a Music Style on floppy disk (p. 63).

15. Fill In buttons

Inserts a fill-in in an automatic accompaniment and changes the accompaniment pattern (p. 69).

[To Variation] button

[To Original] button

16. [Intro/Ending] button

Play an intro or ending during automatic accompaniment (p. 66).

17. [Start/Stop] button

Starts and stops automatic accompaniment (p. 66).

Rhythm Partner

18. [Count/Marker] button

You can change the count settings (p. 160).
These allow you to add and move markers in the notation as well as repeat playback of song segments simply and easily.

19. [Metronome] button

Activates the built-in metronome (p. 52).

20. Beat Indicator

This lights up in correspondence with the beat of the selected song or accompaniment.

21. Tempo [-] [+] buttons

Adjusts the tempo.
Press the [-] and [+] buttons at the same time to return to the original tempo.

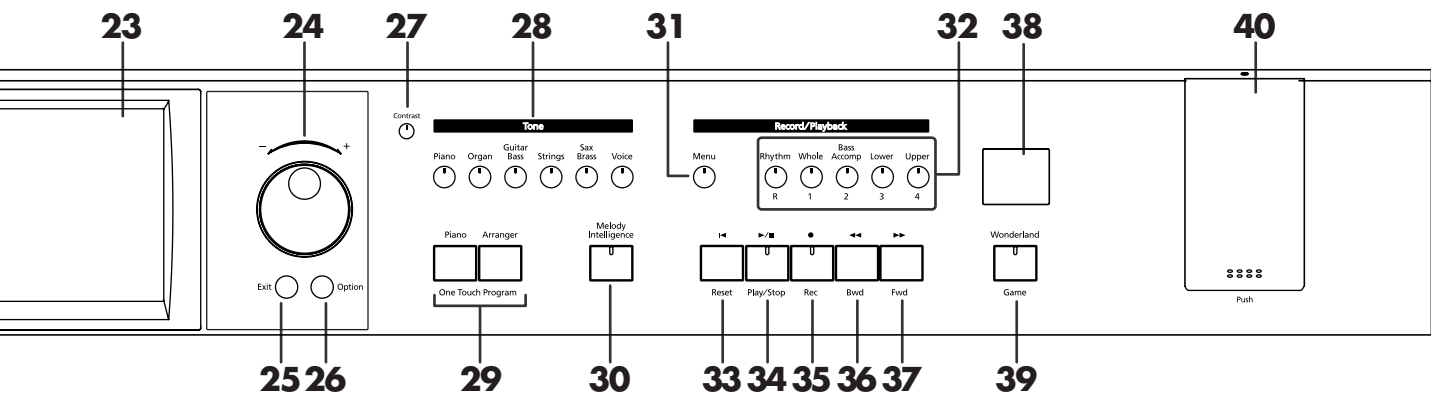

22. Main Buttons

-> See the Quick Start

[Song/File] button

Use this button to select internal songs or songs from floppy disk (p. **).

[DigiScore] button

Displays scores (p. **).

[Visual Lesson] button

You can use the practice function.

[Piano Designer] button

[Music Assistant] button

[Super Tones] button

23. Touch Screen

This lets you perform a variety of operations just by touching the screen (p. **).

24. Dial

Use this to change on-screen values.

25. [Exit] button

Returns you to the previous screen.

26. [Option] button

Displays a screen for advance function settings.

27. Contrast knob

Adjusts the contrast of the screen (p. **).

28. [Tone] buttons

Select the Tones that will be played from the keyboard (p. **).

29. One Touch Program button

[Piano] button

Makes the optimal settings for a piano performance (p. **).

[Arranger] button

Makes the optimal settings for playing with automatic accompaniment (p. **).

30. [Melody Intelligence] Button

Adds harmony to the sounds played with the keyboard (p. **).

Record/Playback

31. [Menu] button

You can select functions for playing back, recording or editing a song (p. **, p. **).

32. Track buttons

Used to play back or record each track of a song (p. **, p. **).

33. [⏪ (Reset)] button

Resets the song playback-start location to the beginning of the song.

34. [▶/■ (Play/Stop)] button

Starts and stops playback or recording a song.

35. [● (Rec)] button

When pressed, this button places the instrument in recording standby (p. **, p. **).

36. [◀◀ (Bwd)] button

Rewinds the song.

37. [▶▶ (Fwd)] button

Fast-forwards the song.

38. Infrared Receiver

Point the remote control at this sensor when using the remote control to operate the KR107 (p. **).

39. [Wonderland/Game] button

Here you can learn about instruments while having fun.

-> See the Quick Start

40. External memory port

Connects an external memory to play and save songs (p. **).

* Be sure to close the cover of the External Memory port after connecting USB memory to the External Memory port. If the cover is left open, someone could get hurt if their legs bump into it; the cover could be damaged as well.

Panel Descriptions

Rear Panel

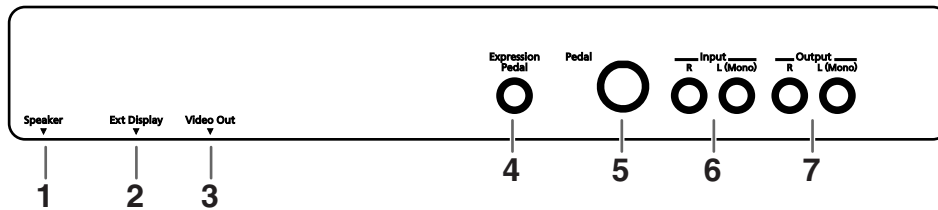

1. Speaker Jack

Connect the speaker cable of the stand (p. **).

2. Ext Display connector

Connect an external display. You can put notations on the screen and display lyrics (p. **).

3. Video Out Connector

Connect a television here. This allows you to display the notations and lyrics on the connected television set (p. **).

4. Expression Pedal jack

You can connect an expression pedal to the KR.

5. Pedal connector

Connect the pedal cable of the stand to this connector (p. **).

6. Input jacks

These jacks can be connected to another sound generating device or an audio device, so that the sound of that device will be output from the KR's speakers (p. **).

7. Output jacks

These jacks can be connected to your audio system to enjoy more powerful sound. They can also be connected to a tape recorder or similar device in order to record your performance on a cassette tape (p. **).

Bottom Panel

Bottom Panel (Front Left)

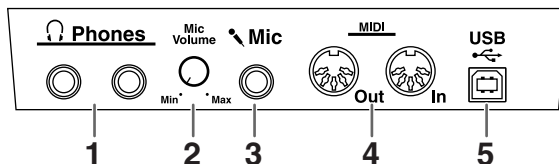

1. Phones jacks

A set of headphones can be connected here (p. **).

2. Mic Volume knob

Adjusts the volume level for the microphone (p. **).

3. Mic In jack

Used for connecting microphones (p. **).

4. MIDI Out/In connectors

These can be connected to an external MIDI device to exchange performance data (p. **).

5. USB Connector

You can connect a computer and exchange performance data between the instrument and the computer (p. **).

Bottom Panel (Front Right)

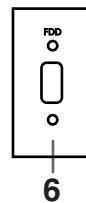

6. Floppy Disk Drive Connector

Connects an optional floppy disk drive to play and save songs (p. **).

* Use floppy disk drive available from Roland.

Before You Start Playing

Connect the Pedal Cable

Insert the pedal cable into the Pedal connector on the rear panel of the KR107.

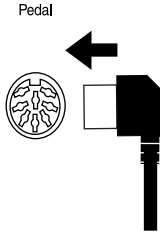

Connect the Speaker Cable

As shown in the diagram, connect the speaker cable leading from the speaker box of the stand to the speaker connector located on the rear panel of the KR107.

Push the speaker cable in until it clicks into position.

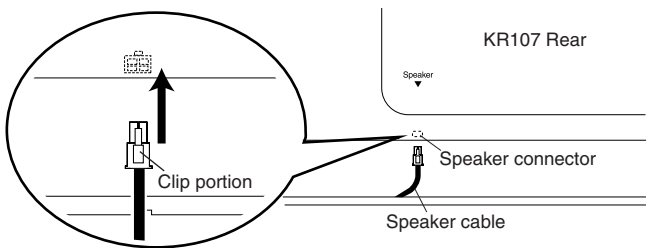

NOTE

Do not place containers holding liquids (such as flower vases), insecticide, perfume, alcohol, or similar substances on top of this piano.

The speakers of this piano are mounted beneath the upper surface, and face upwards. Malfunctions or accidents may occur if liquids contact any part of the speakers.

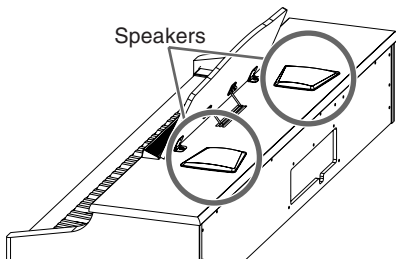

Connect the Power Cord

Insert the included power cord into the AC inlet on the bottom panel of the KR107, and then plug it into an electrical outlet.

NOTE

Be sure to use the supplied power cord.

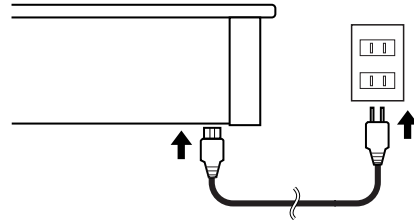

Setting Up the Music Rest

1. Grasping the music rest with both hands, lift it toward you until it is in the upright position.
2. Use the support on the back of the music rest to keep the stand in place.

The angle of the music rest can be set to any of three positions.

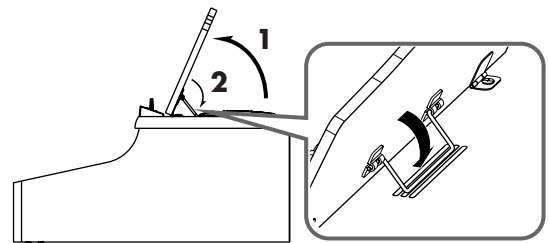

Folding Down the Music Rest

1. Raise the support located on the back of the music rest, then gently fold down the music rest.

Using the Music Holders

You can use the holders to hold pages in place. When not using the holders, leave them folded down.

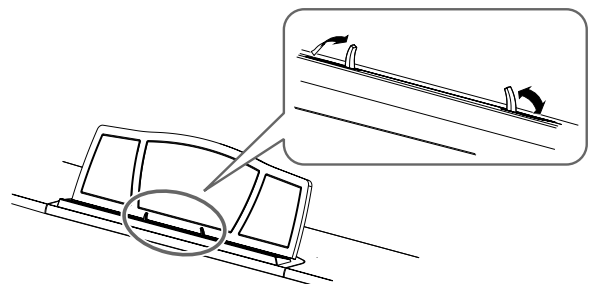

■ Removing the Music Rest

You can remove the music rest from the piano. This allows you to place a notebook computer on the piano.

Position the music rest so it's upright, then remove the three screws, as shown.

You can remove the screws using a coin.

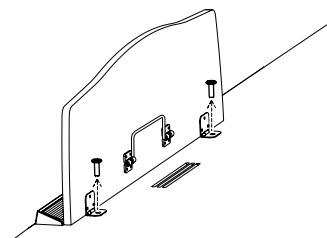

NOTE

Be careful not to lose the screws that you removed from the music rest, or put them where they might be swallowed by small children.

Installing Batteries in the Remote Control

Install the batteries provided in the remote control.

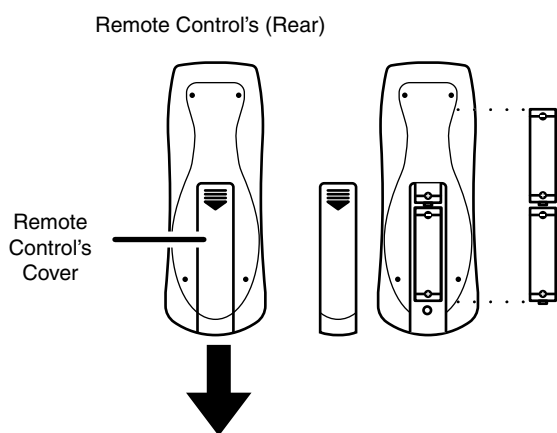

- 1.** Open the battery cover on the back of the remote control.
- 2.** Insert the supplied AA batteries, as shown in the figure of remote control.
- 3.** Close the battery cover.

NOTE

Be careful to observe the correct polarity (+, - direction) when installing the batteries.

MEMO

For more information on the remote control button functions, refer to "Using the Remote Control" (p. 70).

Opening/Closing the Lid

To open the lid, use both hands to lift it lightly, and slide it away from yourself.

To close the lid, pull it gently toward yourself, and lower it softly after it has been fully extended.

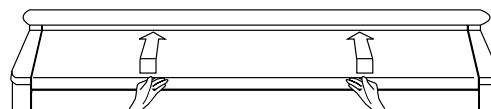

NOTE

When opening and closing the lid, be careful not to let your fingers get caught. If small children will be using the KR107, adult supervision should be provided.

NOTE

If you need to move the piano, make sure the lid is closed first to prevent accidents.

Turning the Power On and Off

NOTE

Turn on power to your various devices in the order specified. By turning on devices in the wrong order, you risk causing malfunction and/or damage to speakers and other devices.

To turn the power on, turn the [Volume] knob all the way down, and then press the [Power] switch.

The power will turn on, and the Power indicator at the left front of the KR107 will light.

After a few seconds, you will be able to play the keyboard to produce sound.

Use the [Volume] knob to adjust the volume.

NOTE

This unit is equipped with a protection circuit. A brief interval (a few seconds) after power up is required before the unit will operate normally.

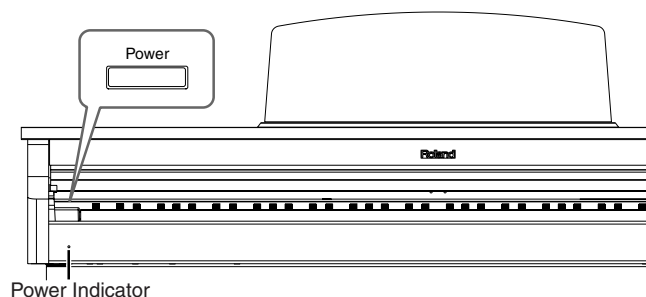

Before You Start Playing

To turn the power off, turn the [Volume] knob all the way to the left, and press the [Power] switch.

The Power indicator at the left front of the KR107 will go dark, and the power will be turned off.

- If you need to turn off the power completely, first turn off the POWER switch, then unplug the power cord from the power outlet. Refer to **Power Supply** (p. 6).

About the Pedals

The pedals have the following functions, and are used mainly for piano performance.

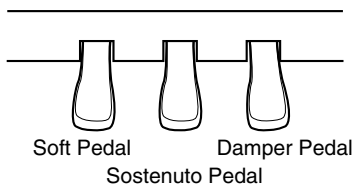

Damper pedal (right pedal)

While this pedal is pressed, notes will be sustained even after you take your fingers off the keys.

On an acoustic piano, holding down the damper pedal will allow the remaining strings to resonate in sympathy with the sounds that you played from the keyboard, adding a rich resonance.

The KR107 simulates this damper resonance.



You can change the amount of resonance applied with the damper pedal. Please refer to "[Piano Designer] button" in the Quick Manual.

Sostenuto pedal (center pedal)

This pedal sustains only the sounds of the keys that were already played when you pressed the pedal.

Soft pedal (left pedal)

When you hold down this pedal and play the keyboard, the sound will have a softer tone.

The softness of the sound changes subtly depending on the extent to which the pedal is depressed.

About the Adjuster

When you move the KR107 or if you feel that the pedals are unstable, adjust the adjuster located below the pedals as follows.

- Rotate the adjuster to lower it so that it is in firm contact with the floor. If there is a gap between the pedals and the floor, the pedals may be damaged. In particular when placing the instrument on carpet, adjust this so that the pedals firmly contact the floor.

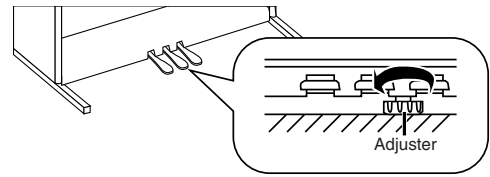

Adjusting the Sound's Volume and Brilliance

Turn the [Volume] knob to adjust the overall volume.

Turn the [Brilliance] knob to adjust the brightness of the sound.



Connecting Headphones

The KR107 has two jacks for plugging in headphones. This allows two people to listen through headphones simultaneously, making it very useful for lessons and when performing piano pieces for four hands. Additionally, this allows you to play without having to worry about bothering others around you, even at night.

Plug the headphones into the Phones jack located at the bottom left of the piano.

Connecting headphones will automatically mute the sound from the internal speakers.

The headphone volume is adjusted by the [Volume] knob of the KR107.

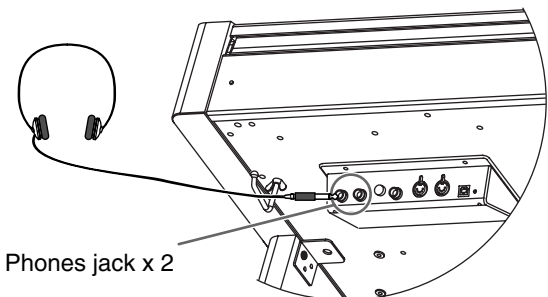

NOTE

Use Stereo headphones.

Some Notes on Using Headphones

- To prevent damage to the cord, handle the headphones only by the headset or the plug.
- Connecting the headphones when the volume of connected equipment is turned up may result in damage to the headphones. Lower the volume on the KR107 before plugging in the headphones.
- Listening at excessively high volume levels will not only damage the headphones, but may also cause hearing loss. Use the headphones at a moderate volume level.

Using the Headphone Hook

Whenever you are not using the headphones, you can hang them on the headphone hook at the lower left of the KR107.

Attaching the Headphone Hook

Press and twist the headphone hook included with the KR107 into the hole in the bottom of the KR107 (refer to the figure below).

Turn the headphone hook thumbscrew to secure the headphone hook.

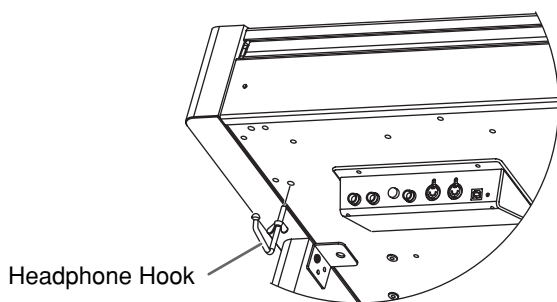

Connecting a Microphone

You can connect a microphone into the Mic In jack, and enjoy karaoke with the KR107.

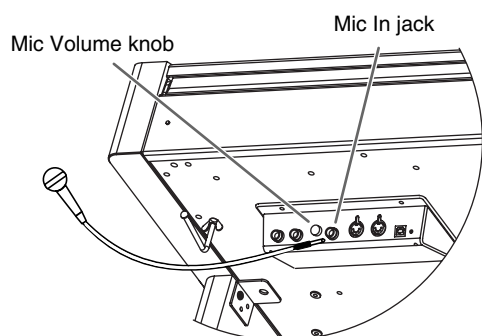

1. Connect a microphone (sold separately) to the Mic In jack on the lower-left area of the instrument.
2. Rotate the [Mic Volume] knob on left side of the Mic In jack to adjust the volume level for the microphone.

Some Notes on Using a Microphone

- Be careful of high volume levels when using microphone late at night or early in the morning.
- When connecting a microphone to the KR107, be sure to lower the volume. If the volume control is too high when the microphone is plugged in, noise may be produced by the speakers.
- Howling could be produced depending on the location of microphones relative to speakers. This can be remedied by:
 1. Changing the orientation of the microphone(s).
 2. Relocating microphone(s) at a greater distance from speakers.
 3. Lowering volume levels.

About the Touch Screen

The KR makes use of a touch screen.

This lets you carry out a wide variety of actions just by touching the screen lightly.

NOTE

The touch screen is operated by touching it lightly with your finger. Pressing hard, or using a hard object can damage the touch screen. Be careful not to press too hard, and be sure to use only your fingers to operate the touch screen.

NOTE

The positioning of the touch screen may become displaced due to changes in the surrounding environment and over time. If this happens, follow the steps in "Calibrating the Touch Screen (Touch Screen)" (p. 149) to correct the pointer position.

NOTE

Do not place items on the touch screen.

■ Adjusting the Contrast of the Screen

To adjust the contrast of the screen, turn the Contrast knob located at the right side of the screen.

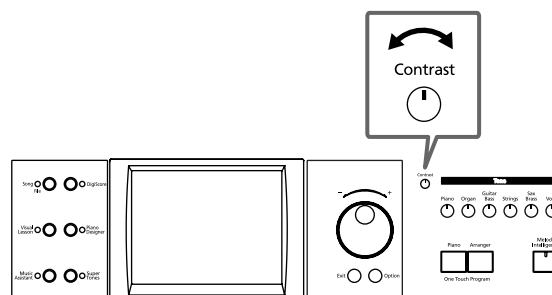

Before You Start Playing

Main Screens

■ Piano Screen

Immediately after the power is turned on, the Piano screen like the one below is displayed. For details, refer to p. 21.



■ Basic Screen

The following screen is called Basic screen.

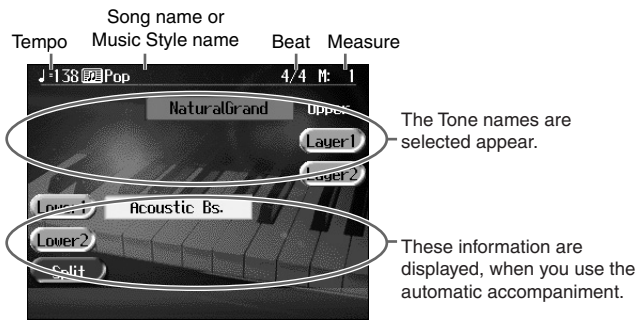

You can usually display this screen by pressing [Exit] button several times.

Follow either of the procedures described below to display it.

- Press the One Touch Program [Arranger] button. The Basic screen appears and the settings are made for automatic accompaniment.
- Press the One Touch Program [Piano] button, then press one of the Tone buttons, then press the [Exit] button.

■ Using the Main Icons

You can many other screens besides the Basic screen to do things. The on-screen graphics that appear three dimensional work like buttons. These are called "Icons."

The main icons you can use on these screens are as follows.

	<p>Some screens consist on two or more pages. You can display the next page or the previous page of the screen by touching these icons.</p>
--	---

	<p>When you select an internal song or music files that includes the lyrics data, this icon appears in the Piano screen or Basic screen. Touch this to display the lyrics.</p>
--	--

NOTE

The explanations in this manual include illustrations that depict what should typically be shown by the display. Note, however, that your unit may incorporate a newer, enhanced version of the system (e.g., includes newer sounds), so what you actually see in the display may not always match what appears in the manual.

■ The [Option] Button and The [Exit] Button

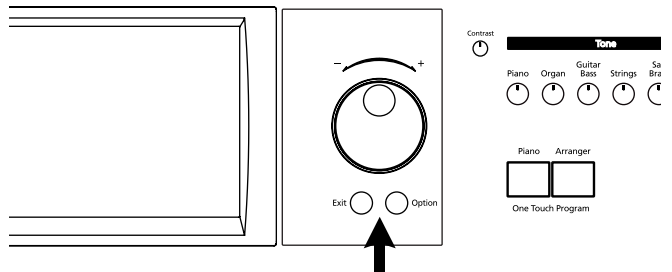

The [Option] Button

This displays a screen for advance function settings.

The screen that opens differs depending on the screen that was displayed when the button was pressed.

The [Exit] button

Touch to cancel the settings currently being made and close the screen displayed. Normally, pressing the [Exit] button one or more times returns you to the Basic screen.

■ The Scroll Bar and The Page Icon

The Song and Tone selection screens feature a scroll bar at the right of the screen list, with page icons at the top and bottom of the scroll bar.



Touch the scroll bar and drag up and down to scroll through the list.

Touch the page icons to change pages.

Chapter 1 Performance

Playing the Keyboard Like a Piano (One-Touch Piano)

You can create the optimal settings for a piano performance with the press of a single button.

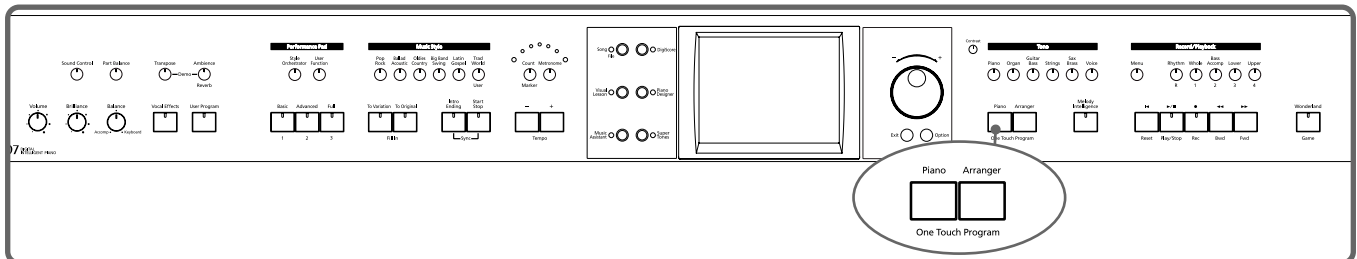

1. Press the One Touch Program [Piano] button.

A “Piano screen” like the one shown below will appear.



When you press the One Touch Program [Piano] button, the KR will switch to the following settings, regardless of the current panel settings.

- If the keyboard has been split into upper and lower sections (p. 26), the keyboard returns to a single section.
- The pedals return to their usual functions (p. 18).
- The Grand Piano sound is automatically selected.
- The effect is automatically set to “Damper Resonance” (p. 35).

MEMO

Since this instrument faithfully reproduces real acoustic piano action and response, keys played in the top one-and-one-half-octave range continue to resonate, regardless of the damper pedal action, and the tone in this range is audibly different. The Key Transpose setting (p. 87) can also be used to change the range that is unaffected by the damper pedal.

MEMO

You can change the piano performance settings by touching the [Piano Designer] button. For more details, refer to “[Piano Designer] Button” in the Quick Start.

MEMO

When you select an internal song or music file that includes the lyrics data, <Lyric> appears in the Piano screen or Basic screen. Touch this to display the lyrics.

MEMO

<Headphones icon> appears in the Piano screen or Basic screen when headphones are connected. You can add three-dimensional breadth to the sound from the headphones (p. 30).

Performing with a Variety of Tones (Tone Buttons)

The KR comes with a many built-in instrument sounds and effects. This lets you enjoy perform in a wide range of musical styles.

The built-in sounds are called “Tones.” The sounds are organized into six tone groups, which are assigned to the [Tone] buttons.



For more about the names of Tones, take a look at the “Tone List” (p. 170).

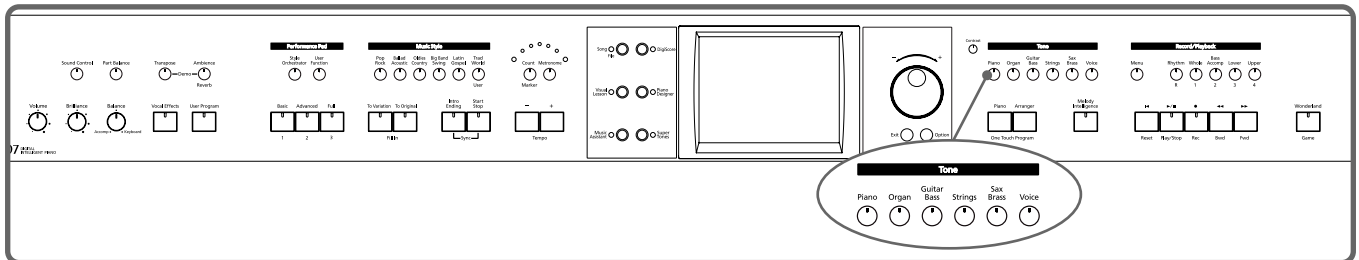

1. Press any one of the Tone buttons to select a tone group.

You'll see that button's indicator light up.

The screen displays the tone names included in the tone group you've selected.

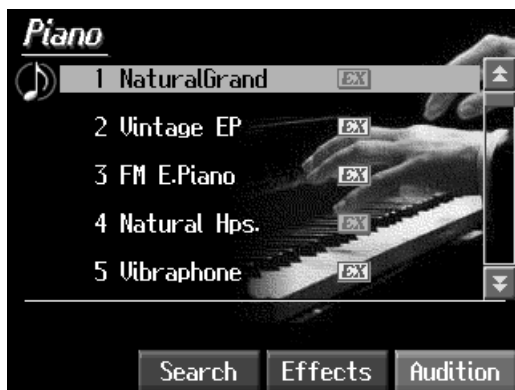

This screen is called the “Tone selection screen.”

Tones indicated by **EX** is called an “EX voice.” These voices are especially recommended.

Tones indicated by a red **EX** mark produce the “Key Off Sound.”

What “Key Off Sound” does is recreate the tonal changes produced when the fingers are released from the keys.

Tones indicated by “GS” is GS tones.

Touch and drag up and down in the scroll bar to scroll through the screen and display other tones.

Touch the page icons to change pages.

You can touch <Audition> for an audio demonstration of a particular tone.

You can touch <Effects> to add effect sounds to a variety of tones (p. 35).

You can touch <Search> to find tones according to the search criteria you specify (p. 24).

2. Touch a tone name to select the tone.

You'll hear the tone you've selected when you play the keyboard.

You can use the dial to scroll through the screen as you switch the Tones to be played.

3. Press the [Exit] button.

This returns you to the Basic screen or the previous screen.

■ Playing Percussion Instruments or Sound Effects

You can use the keyboard to play percussion sounds or effects like sirens and animal sounds.

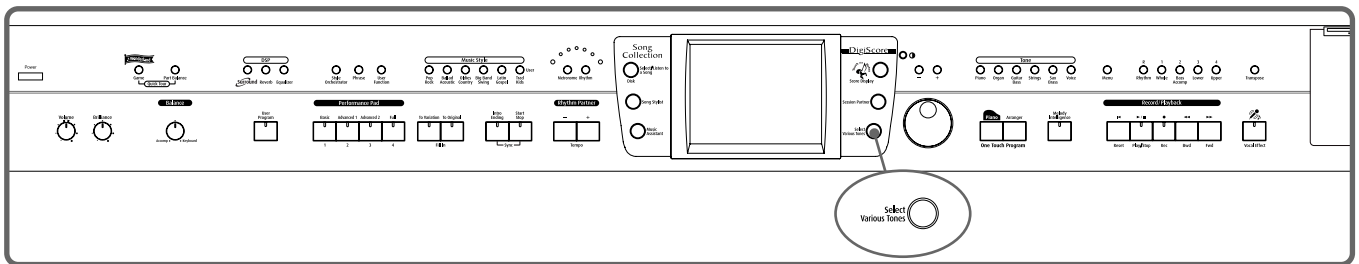

1. Press the [Super Tones] button and watch the indicator light up.

2. Touch << >> several times to display the "Drums" screen or the "SFX" screen.

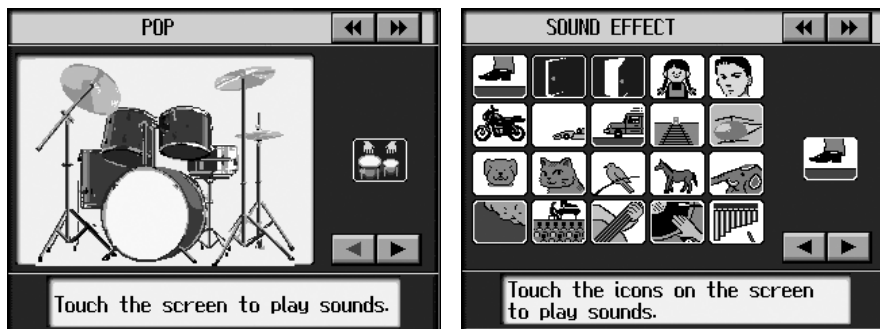

Each note of the keyboard will play a different sound.

You can also have play sounds by touching the screen.

You can select other drum tones and effect sounds by pressing the << >> or <> > buttons.

3. Press the [Exit] button several times.

This returns you to the Basic screen or the previous screen.

MEMO

The combination of sounds assigned to the keyboard varies according to the drum set. Take a look at the "Drum Set List" (p. 172) and "SFX Set List" (p. 177).

■ Using Keywords to Search for Tones (Tone Search)

You can search for tones that match the conditions you set for instrument or musical style. You can also search the tones using the first character of the tone name.

1. Press any Tone button.

The tone selection screen appears.

2. Touch <Search>.

The following “Tone search screen” appears.

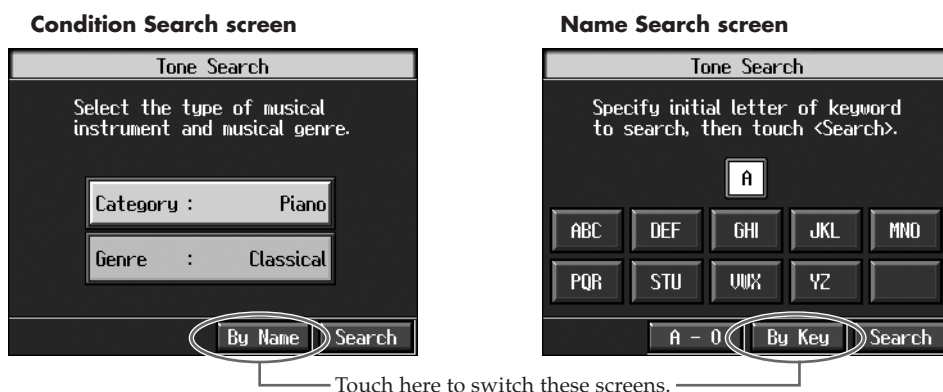

Searching by Conditions

3. Touch <Category> or <Genre>, then use the dial to select the search conditions.

4. Touch <Search>.

The search results appear in the display.

Touch the tone name to select the tone.

Press the [Exit] button to return to the tone search screen.

Searching by Tone Name

3 Touch <By Name>.

Touch <By Key> to go to the condition search screen.

4. Decide which character is to be used for the search.

The selected character appears in the middle of the screen.

Enter the character you’re searching for. For example, touching <ABC> in succession cycles you through the available choices in that character group (“A”→“B”→“C”...).

Touching <A-0> selects the type of character. Each time you touch <A-0>, the character switches between alphabets and numerals.

5. Touch <Search>.

The search results appear in the display.

Touch the tone name to select the Tone.

Press the [Exit] button several times to return to the Basic screen or the previous screen.



In condition search, tones satisfying all of the selected search criteria are sought.

Performing with Multiple Sounds Layered Together (Layer)

Two tones sounding together when you press a single key is referred to as a “layer performance.”

For instance, it’s possible to play the Tones for both Piano and Strings simultaneously.

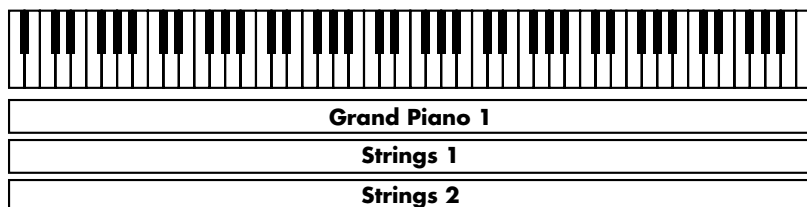

1. Touch <Layer 1> at the bottom of the Basic screen.



The tone that was sounding before you switched to layer performance, plus the tone indicated in the lower part of the display, are now played together.

Here, the tone appearing in the upper part of the display is called the “right-hand tone,” and the tone appearing in the lower part of the display is called the “layer tone.”

In the same manner, you can touch <Layer 2> to layer further sounds.

Changing the tones

2. Touch the name of the tone to be changed.
Touch here to highlight the tone name.
3. Press a Tone button to select the new tone (p. 22).
4. When you have selected the tone, press the [Exit] button.

The display returns to the Basic screen.

Cancelling the Layer

5. Touch <Layer 1>.

Touch <Layer 2> to have <Layer 2> play as well.

The <Layer 1> and <Layer 2> icons are dimmed, and the Layer performance is cancelled.

Now when you play the keys, only the tone indicated on the screen is sounded.



When you select an internal song or music file that includes the lyrics data, <Lyric> appears in the Basic screen. Touch this to display the lyrics.



<🎧> appears in the Piano screen or Basic screen when headphones are connected. You can add three-dimensional breadth to the sound from the headphones (p. 30).



When you touch Octave <-><+> on the tone selection screen, the pitch of the keyboard’s sound is changed in octave units. To learn more, see “Shifting the Keyboard Pitch in Octave Steps (Octave Shift)” (p. 27).



You can change the balance of the right-hand and Layer Tone volume. For instructions, see “Adjusting the Volume Balance for Each Performance Part (Part Balance)” (p. 62).

Playing Different Tones with the Left and Right Hands (Split)

Dividing the keyboard into right-hand and left-hand areas, then playing different sounds in each section is called “split performance.” The boundary key is called the “split point.”

The split point key is included in the left-hand keyboard area. Each time power to the keyboard is turned on, the split point is reset to “F#3.”

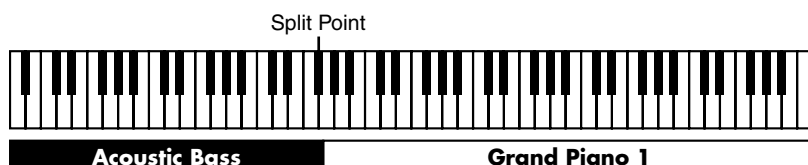

1. At the Basic screen, touch <Split>.



The tone sounding prior to the split performance is played in the right-hand section of the keyboard, and the tone indicated at the left of the screen is played in the left-hand section of the keyboard.

Here, the tone appearing at the right part of the display is called the “right-hand tone,” and the tone appearing at the left part of the display is called the “left-hand tone.”

Changing the Tones

2. Touch the name of the tone to be changed.
3. Press a Tone button to select the tone (p. 22).
4. When you have selected the tone, press the [Exit] button.

The display returns to the Basic screen.

Cancelling the Split

5. Touch <Split>.

+++++

When you play the keys, only the tone indicated on the screen is sounded.



You can change the split point; refer to “Changing the Keyboard’s Split Point (Split Point)” (p. 138).



When you select an internal song or music file that includes the lyrics data, <Lyric> appears in the Basic screen. Touch this to display the lyrics.



<Headphones> appears in the Piano screen or Basic screen when headphones are connected. You can add three-dimensional breadth to the sound from the headphones (p. 30).



When you touch Octave <-><+> in the tone selection screen, the pitch of the keyboard’s sound is changed in octave units. To learn more, see “Shifting the Keyboard Pitch in Octave Steps (Octave Shift)” (p. 27).



You can change the volume balance between the left- and right-hand parts of the keyboard; refer to “Adjusting the Volume Balance for Each Performance Part (Part Balance)” (p. 62).

Turning On Layer and Split Performance Simultaneously

Turning on either Layer Performance or Split Performance allows you to divide the keyboard into a right-hand and a left-hand part and play with two Tones layered in the right-hand part.



■ Shifting the Keyboard Pitch in Octave Steps (Octave Shift)

When using layer performance (p. 25) or split performance (p. 26), you can change the pitch of the keyboard's sound in octave units. This function is called "Octave Shift."

For example, when using a layer performance, you can change the pitch of each sound and layer the sounds. You can make the pitch of the keyboard's left-hand part match the pitch of the right-hand part during split performance.

1. On the Basic screen, touch <Layer> or <Split>. The KR switches to layer performance or split performance.
2. To apply Octave Shift, touch the name of the tone you've selected.
3. Press the Tone button to display the Tone selection screen.



4. Touch Octave <-> or <+> in the lower part of the screen to adjust the pitch of the sound.

Each time you touch <+>, the pitch is raised one octave.

Each time you touch <->, the pitch is lowered one octave.

The sound can be changed from two octaves lower than the original sound (-2) to two octaves above the original (+2).

Press the [Exit] button to return to the Basic screen or the previous screen.

MEMO

When the keyboard has been divided into upper and lower sections, the damper pedal is applied to only the upper section. If you want to add lingering reverberations to the notes of the lower section, see "Assigning Functions to Pedals and Performance Pads (Pedal Setting/User Functions)" (p. 142).

Adding Reverberation to the Sound (Reverb)

Apply a reverb effect to the notes you play with the KR.
 Reverb makes it sound as if you are playing in a concert hall.

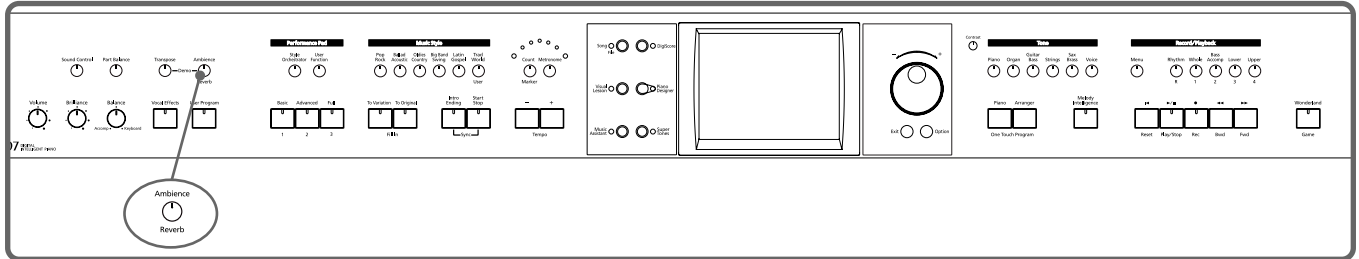

1. Press the [Ambience/Reverb] button and watch the its indicator light up.

A “Reverb screen” like the one shown below appears.



2. Touch an icon to select the performance space.

Display	Explanation
Hall 1	Hall with bright reverberation
Hall 2	Hall with warm reverberation
Room 1	Room reverberation
Cathedral	High-ceilinged cathedral
Ground	Wide open space with no reverberations
Room 2	Small room
Lounge	Larger room
Studio	A recording studio
Gymnasium	In a gymnasium
Hall 3	Large concert hall reverberation
Dome	A domed ballpark
Cave	Adds the extended reverberations found inside a cave
GS Room 1	Reproduces an indoor-type reverb. Provides a clear, expansive reverberation.
GS Room 2	
GS Room 3	
GS Hall 1	Reproduces the reverberation found in a hall. Gives reverberation with a greater sense of depth than GS Room.
GS Hall 2	

Display	Explanation
GS Plate	Reproduces a plate echo (reverberation created using the vibrations of a metal plate).
GS Delay	A delayed sound that is added to the original, similar to the reflected sounds of mountain echoes.
GS Pan Delay	The reflected sounds are panned (shifted) laterally.

3. Touch the slider beneath the icons to adjust the effect selected.

Touch and slide the knob on the screen to the right for a deeper reverb, and to the left for less.

You can also move the slider with the dial.

When you press the [Exit] button, the reverb effect is activated, and you return to the previous screen.

Canceling the Effect

4. Press the [Ambience/Reverb] button, and watch the indicator light go out.

The reverb effect is eliminated.



No effect is applied when the slider is moved all the way to the left. In this case, the button's indicator won't light up when you press the [Ambience/Reverb] button.

Adding Three-Dimensional Breadth to the Sounds You Play (Advanced 3D)

You can add three-dimensional breadth to the sounds you play with automatic accompaniment (p. 46), or to internal songs or music files. With this effect, called “Advanced 3D,” you seem to be surrounded by the sound of the performance.

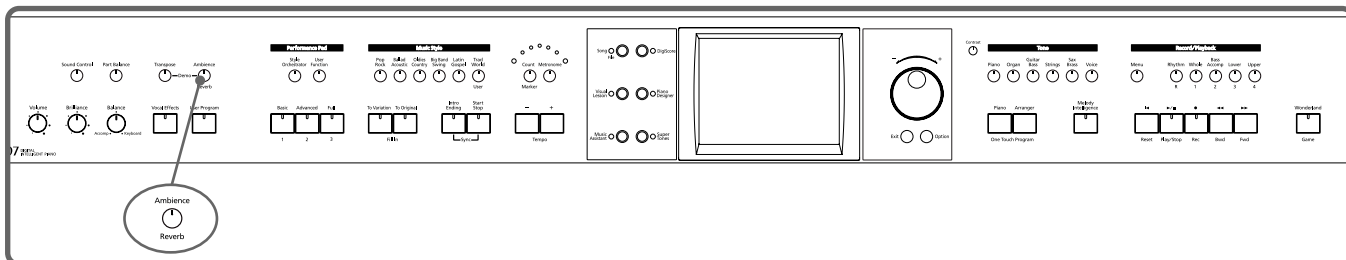

1. Press the [Ambience/Reverb] button and watch the indicator light up.
2. Touch <Advanced 3D>.

The following “Advanced 3D screen” appears.

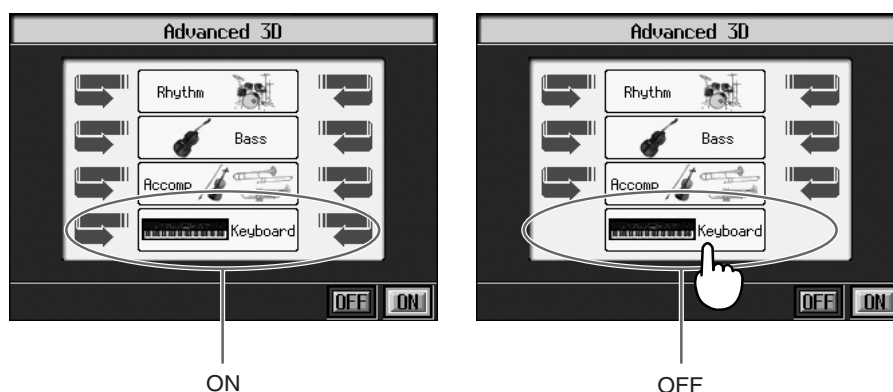

3. Touch <ON>.
- Three-dimensional breadth is added to the sound.
4. Touch the icon to switch the effect on or off for each individual part.
- When you press the [Exit] button, the Advanced 3D effect is activated, and you return to the previous screen.

Canceling the Effect

5. Touch <OFF>.
- The Advanced 3D effect is eliminated, and the effect is no longer applied to any of the parts.

MEMO

<*** > appears in the Piano screen or Basic screen when headphones are connected. You can add three-dimensional breadth to the sound from the headphones (p. 30).

MEMO

<🎧 > appears in the Piano screen or Basic screen when headphones are connected. You can add three-dimensional breadth to the sound from the headphones (p. 30).

MEMO

The Advanced 3D effect is not applied, even when you touch <On>, if all parts are turned off.

○ Making Detailed Settings for Advanced 3D

1. Press the [Ambience/Reverb] button and watch the indicator light up.
2. Touch <Advanced 3D>.
3. On the Advanced 3D screen, press the [Option] button.

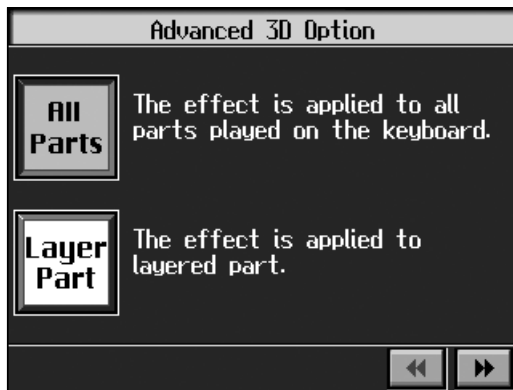

4. Touch   for the parameter being set to select the value.

Parameter	Display	Explanation
Part	All Parts	The effect is applied to all tones played with the keyboard (the left-hand tone, right-hand tone, and layer tone).
	Layer Part	The effect is applied only to the layer part. When not using a layer performance (p. 25), the Advanced 3D effect is not applied to the keyboard performance, even if <Keyboard> on the Advance 3D screen is set to On.
Mode	Auto	This selects settings that are adjusted for use with headphones when headphones are connected. When no headphones are connected, settings adjusted for speakers are selected.
	Speaker	Settings adjusted for listening to sounds through speakers are selected.
	Headphone	Settings adjusted for listening to sounds through headphones are selected.
Depth	1–4	Changes the apparent depth of the sound. The effect is applied more as the value is increased.
Width	ON, OFF	Changes the breadth of the sound.

You can also change the value with the dial.

5. When you press the [Exit] button, you return to the Advanced 3D screen.

Adding Liveliness to the Sound (Dynamic Emphasis)

You can add liveliness to the sound to give it superb clarity and distinctness.

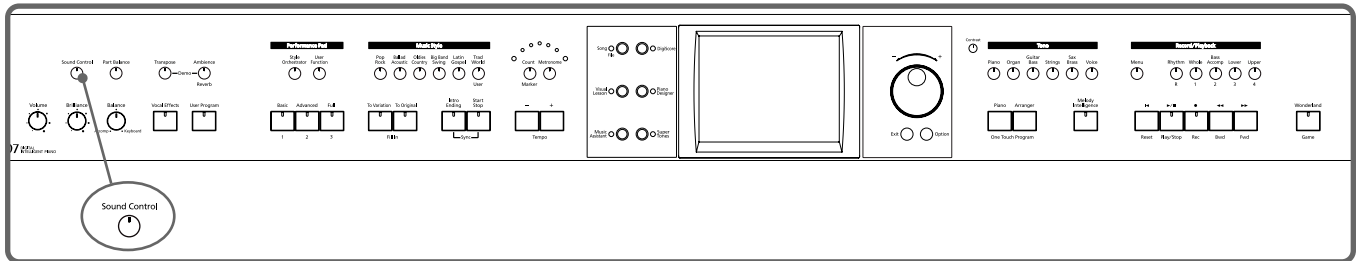

- 1 Press the [Sound Control] button, to display the “Sound Control screen.”

The Dynamic Emphasis function is switched on, enlivening the sound.



- 2 Touch the Type icon to select the type.

Indicator	Description
Sharp	Creates a sound with boosted bass and treble.
Clear	Produces a sound with chords in the low registers that are clear and distinct.
Power	Creates a sound with boosted bass.

- 3 Touch <Off> to cancel the Dynamics Emphasis function.

Adjusting the Sound to Achieve the Preferred Tone Quality (Equalizer)

The KR features a built-in, five-band digital equalizer.

An equalizer boosts or cuts specific sound pitches (frequency ranges) to adjust the sound balance for the overall performance. For example, you can boost the highs to get a crisper sound, or boost the low end for a more powerful sound.

You can also adjust the sound to compensate for the acoustical characteristics of the performance space.

If raising the slider for each frequency ends up distorting the sound, you can correct the distortion with the Master Level slider.

1. Press the [Sound Control] button, to display the “Sound Control screen.”
2. Touch <Equalizer>.

The “Equalizer screen” appears.



3. Touch the Type icon to make your selection.

Display	Explanation
Piano	The optimal settings for piano performance are selected.
Power	Boosts both the low- and high-frequency ranges.
Mild	Lows and highs are restrained for a pleasant-sounding tone.
Clear	This setting slightly boosts the midrange for a simple pop feeling.
Bright	This setting boosts the high frequencies for a brilliant, sparkling sound.
Flat	All slider values are set to “0.”
User	Store your own preferred settings (p. 34).

4. Touch the slider to make adjustment.

Displayed	Settings Value	Explanation
Low	-60–0–+60	Low-frequency range. This is the range of frequencies for instruments like drums, bass, organ, guitar and strings.

Displayed	Settings Value	Explanation
–	-60–0–+60	Mid-low-frequency range. This is the range of frequencies for lower brass and woodwind instruments.
Mid	-60–0–+60	Midrange. This is the range of frequencies where most instrument sounds are concentrated.
–	-60–0–+60	Mid-high-frequency range. The ear is most sensitive to this frequency range.
High	-60–0–+60	High-frequency range. These frequencies add brilliance to the sound.
Master Level	-60–0–+60	You can temper the distortion in the sound by lowering the level. Raising the level too much may cause the sound to become distorted.

You can also move the slider with the dial.

When you press the [Exit] button, the equalization is placed in effect, and you return to the previous screen.

Canceling the effect

5. Touch <Flat>.

○ Storing the settings

You can store adjusted equalizer settings to <User>.

Even after editing the settings, you can touch <User> to call up your preferred settings.

1. Press the [Sound Control] button and watch the indicator light up.
2. Touch <Equalizer>.
The “Equalizer screen” appears.
3. Adjust the equalizer.
4. Touch <Write>.

The settings are stored.

Even after editing the settings, you can touch <User> to select the stored settings.

Applying Effects to the Sound (Effects)

You can apply a wide range of different effects to the notes you play on the keyboard.

1. First, press the Tone button to select a Tone (p. 22).

The "Tone selection screen" appears.

2. Then, touch <Effects>.

The "Effect screen" appears.

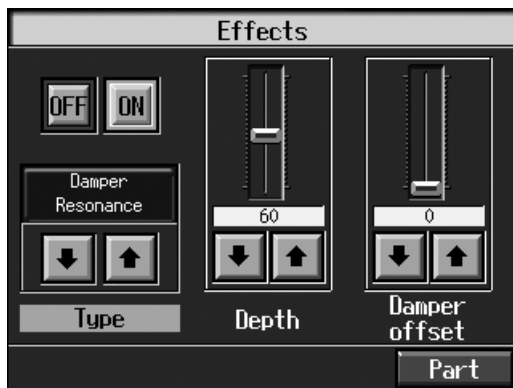

Applying effects to the sound

3. Touch <ON>.

The effect selected with <Type> will be applied.

Selecting the type of Effect

4. Touch <Type>   to select the type of effect.

Setting the Effect

The parameters that can be set change according to the type selected in Step 4.

5. Touch   for the parameter being set to select the value.

You can also move the slider with the dial.

Press the [Exit] button to return to the Tone selection screen.

Cancelling the Effect

6. On the Effects screen, touch <Off>.

MEMO

For more on the effect types, refer to the "Effects List" (p. 176).

NOTE

The effect is not applied to the layer tone or left-hand tone if the effect is different than that applied to the right-hand tone. Select the same effect.

NOTE

You may find effects not being applied to certain parts when different effects are applied to the right-hand tone, layer tone, and left-hand tone. In such instances, you can select which effect is to have priority.

Adding Effects to Mic Vocals (Vocal Effect)

With a microphone connected, you can add effects to the microphone vocals. Adding effects to the vocals is referred to as “Vocal Effect.”

○ How to select Vocal Effect



For details on connecting a microphone, refer to “Connecting a Microphone” (p. 22).

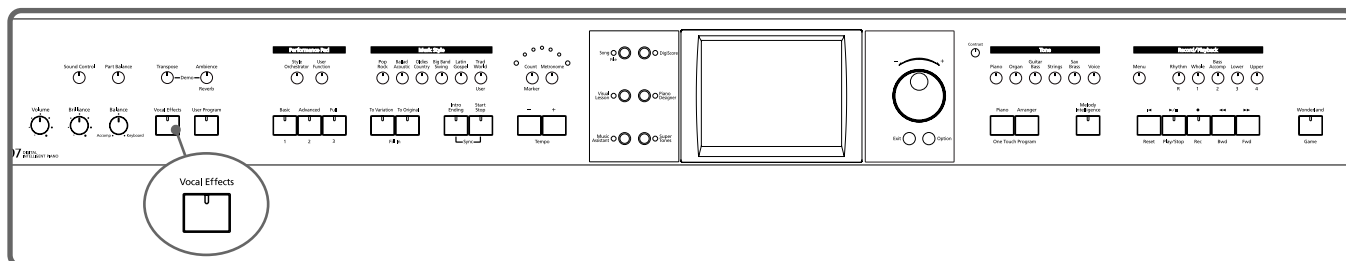

1. Press the [Vocal Effects] button.

The “Vocal Effects screen” appears.

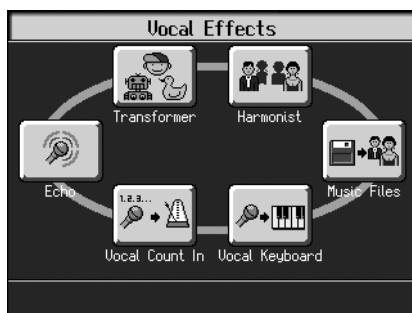

2. Touch any one of the icons.

Icon	Explanation	Page
Echo	Adjusts the microphone echo.	p. 37
Transformer	Alters the microphone vocals.	p. 37
Harmonist	Adds harmonies to the original voice.	p. 45
Vocal Count In	Allows you to start songs and Automatic Accompaniment using your own tempo.	p. 39
Vocal Keyboard	Allows you to produce sounds conforming to the vocal scale.	p. 40
Music Files	You can play a specific part as harmony while playing back a song.	p. 41

3. When you press the [Exit] button, the effect is applied and you return to the previous screen.



You can adjust the microphone volume with the Mic Volume knob on the (left) underside of the KR107.

Cancelling the Vocal Effect

4. Press the [Vocal Effects] button and watch the indicator light go out.

The Vocal Effect function is cancelled.

Adjusting the Echo (Echo)

1. Touch <Echo> in Step 2 of “How to select Vocal Effect” (p. 36).



2. Touch the bar graph to adjust the amount of echo applied to the vocal.

3. Touch the Echo Type <1> or <2> to change the echo type.

Displayed	Explanation
1	Adds basic reverberations.
2	Adds reverberations for a karaoke-type echo.

Press the [Exit] button to return to the Vocal Effects screen.

Altering Vocals (Transformer)

You can modify the way your voice sounds through the microphone. This is called the “Voice Transformer” function.

1. Touch <Transformer> in Step 2 of “How to select Vocal Effect” (p. 36).

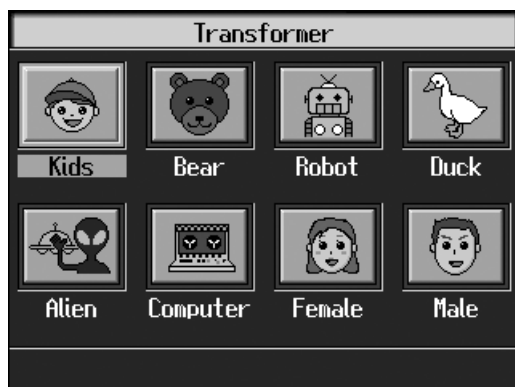

When you use the Voice Transformer function, the resonance setting for the piano (see p. 152) may sometimes be reset.

2. Touch any one of the icons.

Here's what the different icons do.

Display	Explanation
Kids	Transforms the input into the sound of a child's voice.
Bear	Transforms the input sound into the voice of a large animal.
Robot	Transforms the input into the sound of a robot's voice.
Duck	Transforms the input into a duck's quacking sound.
Alien	Transforms the input into an alien voice.
Computer	Transforms the input into a voice like that from a computer.
Female	Transforms male voices into female voices.
Male	Transforms female voices into male voices.

3. Sing through the microphone.

Your voice is transformed according to the item you selected.

Canceling the Effect

4. Once again, touch the icon you selected in Step 2.



The Voice Transformer effect is eliminated.

Press the [Exit] button to return to the Vocal Effects screen.

○ Adding Harmonies (Harmonist)

You can sing with a harmony accompaniment, even when you're playing solo. This is called the "Harmonist" function.

1. Touch <Harmonist> in Step 2 of "How to select Vocal Effect" (p. 36).

Touch   to switch the screen.



2. Touch any one of the icons.

Here's what the different icons do.

Display	Explanation
My Voice	The melody played on the keyboard is played as the harmony. The harmony is added to your voice regardless of the pitch.
Duo1	The added harmony matches the chords specified on the keyboard. Adding harmony to a single voice gives the effect of two people singing together.
Duo2	
Variety	The melody played on the keyboard is played as the harmony. The harmony added is matched to the pitch; for example, higher pitches are used for female voices, lower pitches for male voices.
Trio	The added harmony matches the chords specified on the keyboard. This adds a two-voice harmony that makes it seem that a trio is singing.
Chord	The added harmony matches the chords specified on the keyboard. You can change the way harmonies are added with the Melody Intelligence type (p. 59).
Unison	Sounds like two people singing the same melody.
Oct-Up	Adds another voice one octave higher than the original.
Oct-Down	Adds another voice one octave lower than the original.
5th Up	Adds harmony a fifth above the original.
3rd Up	Adds harmony a third above the original.
4th Down	Adds harmony a major fourth below the original.

Cancelling the Effect

3. Touch the Harmonist type you selected in Step 2 again.

The Harmonist function is cancelled.

Press the [Exit] button to go back to the Vocal Effects screen.

○ Enabling the start of songs and automatic accompaniment with the sound of your voice (Vocal Count-In)

You can start songs and the Automatic Accompaniment by counting into the microphone.

1. Touch <Vocal Count In> in Step 2 of "How to select Vocal Effect" (p. 36).



2. Touch <Arranger> or <Song>.

Display	Explanation
Arranger	Automatic Accompaniment starts at the tempo used for the count.
Song	The song starts at the tempo used for the count.

3. Count to four (“One, two, three, four”) into the mic.

Count out the number of beats per measure in the time signature of the selected song or Music Style.

For example, if you select a time signature of 4/4, then count to four; count to three when 3/4 time is selected.

The tempo is automatically set according to the interval between the counts as you speak into the microphone, and the song or Arranger begins.

Press the [Exit] button to return to the Vocal Effects screen.

○ Playing instrument sounds at vocal pitches (Vocal Keyboard)

You can have melodies sung into the microphone played with the KR’s internal Tones.

1. Touch <Vocal Keyboard> in Step 2 of “How to select Vocal Effect” (p. 36).



2. If the <OFF> icon is selected, touch the <ON> icon.

3. Touch any of the icons to select a Tone.

You can also select the Tone by pressing the Tone button.

When you sing into the microphone, the sung pitches are played using the selected Tone.

cancelling the effect

4. Touch <OFF>.

The Vocal Keyboard function is cancelled.

Press the [Exit] button to go back to the Vocal Effects screen.



When you play the keys while using Vocal Keyboard, the tone selected for Vocal Keyboard is played.

○ Adding harmonies to a specified part (Music Files)

When you sing while playing back a specified part from song data, harmony is added based on pitches of the specified part.

1. Select the song to which you want to add harmony.

To select a song stored in external memory, connect the external memory to the external memory port.

2. Touch <Music Files> in Step 2 of “How to select Vocal Effect” (p. 36).



3. Touch the icon for the part to which you want to add harmony.

When you play back the song and sing into the mic, harmonies are added using the pitches of the specified part.

4. Touch <Variety>.

When <Variety> is ON, the melody played on the keyboard is played as the harmony. The harmony added is matched to the pitch.

Cancelling the effect

5. Touch the icon you selected in Step 3 again.

The Music Files function is cancelled.

Press the [Exit] button to go back to the Vocal Effects screen.

■ Enjoying Karaoke Performances with Music Files

1. Connect a microphone.

2. Adjust the volume level and the amount of echo applied.

On the KR, use the Vocal Effect function to adjust the echo (p. 37).

You can also enjoy this effect with the Voice Transformer function (p. 37) and Harmonist function (p. 38, 45).

3. Select a song.

To select a song stored in external memory, connect the external memory to the external memory port. For instructions on how to select songs, refer to "Playing a Song" (p. 64).

4. Adjust the tempo as required with the Tempo [-] [+] buttons.

5. If necessary, change the key of the song (p. 87).

When you press the [▶/■ (Play/Stop)] button, the accompaniment starts playing.

Sing along with the accompaniment.

When you play back a Music File with lyrics, the lyrics appear on screen.

6. Press the [▶/■ (Play/Stop)] button to stop the accompaniment.



Commercial music files designed for "karaoke" sing-along are also available.

Consult your KR dealer when purchasing music files. Refer to "Music Files That the KR Can Use" (p. 183).



On the KR, lyrics can also be shown on an external display. Refer to "Connecting an External Display" (p. 23) and "Selecting Images To Be Shown on the KR and External Displays (User Image Display)" (p. 146).



You can stop lyrics from being displayed. Refer to "Hiding the Lyrics (Lyrics)" (p. 153).

Using the Metronome

The KR features a built-in metronome. During playback of the song and accompaniment, the metronome plays at that tempo and beat.

MEMO

During playback of a song, or when performing with automatic accompaniment, the sound of the metronome keeps time with the beat of the song or accompaniment.

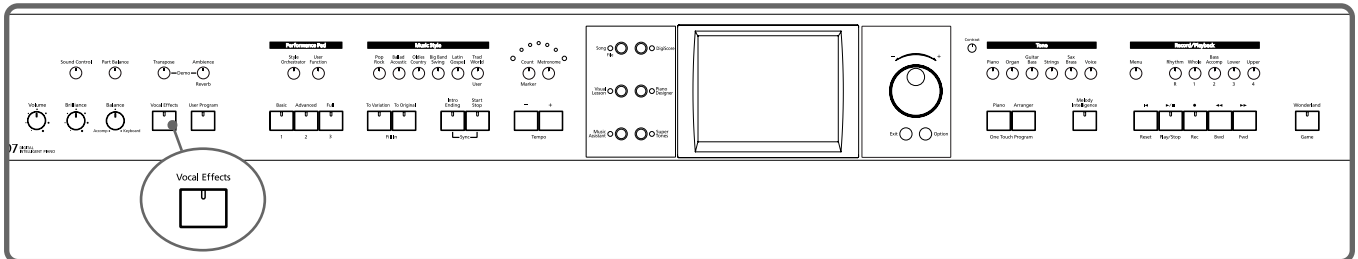

■ Using the Metronome

1. Press the [Metronome] button and watch the indicator light up.

You will hear the metronome.

The following “Metronome screen” appears.



You can press the [Exit] button to have the metronome continue to play while you return to the previous screen.

Stopping the metronome

2. Press the [Metronome] button once more, and the indicator light goes out.

■ Changing the Metronome Settings

○ Adjusting the tempo

You can adjust the tempo of the metronome. The tempo of the metronome changes automatically if you use an Automatic Accompaniment or play back a song.

1. Press the Tempo [-] or [+] buttons to adjust a tempo.

You can adjust the metronome tempo over a range of ♩ = 10–500.

Pressing the Tempo [-] and [+] buttons simultaneously returns the selected song accompaniment to the basic tempo.

○ Changing the beat of the metronome

1. On the Metronome screen, touch <Beat>.

2. Select the beat with the dial.

MEMO



When $\frac{0}{4}$ is selected, only the upbeat will sound.

○ Changing the volume

The volume of the metronome can be adjusted to ten different levels.

1. On the Metronome screen, touch <Volume>.

2. Select the volume with the dial.

Choosing  sets the volume to the lowest level, and choosing  sets it to the highest level.

Choose  to silence the metronome sound.



○ Changing the Type of Sound





You can change the sound the metronome makes.

The setting is at “normal metronome sound” when the KR is powered up.

1. On the Metronome screen, touch <Sound>.

2. Select the sound with the dial.







Displayed	Explanation	Displayed	Explanation
	Normal metronome sound		Electronic metronome sound
いち、に、	“1, 2, 3” in Japanese	One, two,	“1, 2, 3” in English

Displayed	Explanation	Displayed	Explanation
	Dog and cat sounds		Wood block
	Triangle and castanet		Hand clap

○ Changing how the metronome beat (pattern) sounds

You can set the Metronome to play at even smaller intervals.

1. On the Metronome screen, touch <Pattern>.
2. Select the pattern with the dial.

Displayed	Explanation	Displayed	Explanation
Normal	Usual sound		Dotted half-note intervals
	Half-note intervals		Dotted quarter-note intervals
	Quarter-note intervals		Dotted eighth-note intervals
	Eighth-note intervals		Sixteenth-note intervals
+Doubl	Single back beat added	+Tripl	Triplet rhythm added
+Shufl	Shuffle rhythm added		

○ Turning Off the Beat Light (Beat Indicator)

The beat light flashes in time with the metronome, accompaniment Styles, and song tempos, but you can set it so that it stays off at all times.

1. Touch <Beat Indicator> in the Metronome screen.
2. Select On/Off (Beat Indicator off) with the dial.

Chapter 2 Automatic Accompaniment

Music Styles and Automatic Accompaniment

What is Automatic Accompaniment?

Press the One Touch Program [Arranger] button for Automatic Accompaniment's optimum settings. Automatic Accompaniment is a function that provides you with accompaniment in a variety of musical genres, just by specifying chords in the left hand. Automatic Accompaniment lets you play with an orchestra, even when performing alone!

What Are Music Styles?

Accompaniment patterns in various musical genres are called "Music Styles."

There are many different kinds of music around the world, and each has its own unique features. What gives jazz or classical music their unmistakable sounds are a unique combination of elements like instrumentation, melody, and phrasing, which interact to create the musical character.

Elements of Music Styles

A Music Style consists of a set of six sections called "divisions."

Division	Explanation
Intro	Played at the start of a song.
Original	The basic accompaniment pattern.
Variation	This is a variation on the Original accompaniment pattern.
Fill In To Original	This is a one-measure phrase inserted at a point where the mood changes and the accompaniment returns to the original.
Fill In To Variation	This is a one-measure phrase inserted at a point where the mood changes and the accompaniment moves ahead to the variation.
Ending	The conclusion of a song.

In addition, Music Styles are built from: "Rhythm," "Bass," "Accompaniment 1," "Accompaniment 2," "Accompaniment 3," "Accompaniment 4," "Accompaniment 5," and "Accompaniment 6."



For instructions on playing the Automatic Accompaniment, refer to "Selecting Music Styles (Music Style Buttons)" (p. 50).

Performing Using Automatic Accompaniment (One-Touch Arranger)

Here's how to create the settings for Automatic Accompaniment.

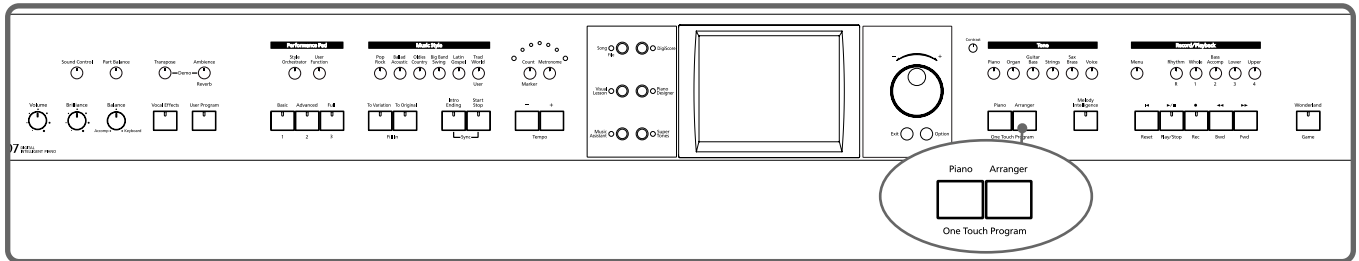

1. Press the One Touch Program [Arranger] button.

The Basic screen like the one shown below appears.



Observe the settings:

- The keyboard is split into left- and right-hand parts, with accompaniment chords specified for the left-hand side of the keyboard.
- A tone appropriate for the selected Music Style is chosen.
- The tempo and beat for the selected Music Style is set.

2. Play a chord on the lower-part of keyboard.

The accompaniment begins, starting from the intro.

Play chords with the left hand, and the melody with the right.

When you change chords in the left hand, the accompaniment also changes.

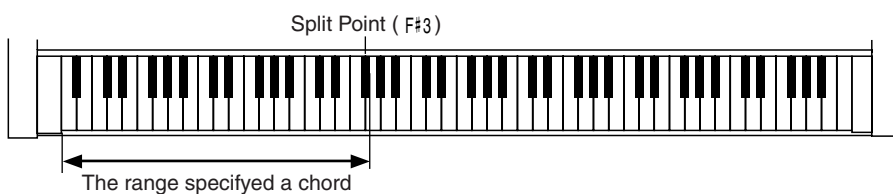

3. Press the [Intro/Ending] button.

After the ending plays, the accompaniment stops.

MEMO

<***> appears in the Piano screen or Basic screen when headphones are connected. You can add three-dimensional breadth to the sound from the headphones (p. 33).

MEMO

Normally, when you change a Music Style, the tempo and tone change to selections that go well with the selected Music Style. If you do not want to change the tempo and tone, refer to “Changing Music Styles Without Changing the Tone or Tempo (One Touch Setting)” (p. 138).

MEMO

For instructions on selecting Music Styles, refer to “Selecting Music Styles (Music Style Buttons)” (p. 50).

MEMO

For instructions on starting and stopping the accompaniment, refer to “Starting and Stopping the Accompaniment” (p. 54).

MEMO

You can change the range in which chords are played. Please refer to “Changing the Keyboard’s Split Point (Split Point)” (p. 138).

About Chords

A chord is produced when several notes are played simultaneously. Chords are indicated by the pitch of the fundamental note of the chord (the root) and the chord type, which is determined by the other notes of the chord.

For example, the C m chord is expressed in terms of the root note "C" and the chord type "m" (minor). C m is made up of the three notes "C," "E ♭" and "G."

"C m" is indicated as the chord name on the Basic screen.

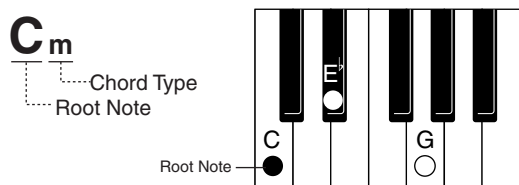

All chord roots are indicated as a letter, sometimes with # or ♭ added, and correspond to the notes shown below.

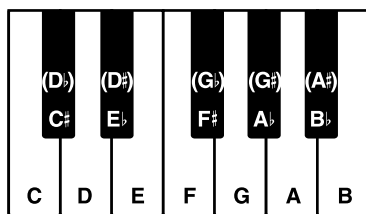

Playing Chords with Simple Fingering (Chord Intelligence)

"Chord Intelligence" is a feature that chooses the accompaniment chords the moment you play a key.

To play a "C" chord, for example, you normally have to play the three keys C, E, and G. But with Chord Intelligence, you only have to press the C key to start a "C" chord accompaniment.

• Intelligence 1

Major

Ex: C



Play the chord root.

Minor

Ex: C m



Play the root and the third key above it.

Seventh

Ex: C 7



Play the root and the second key above it.

Minor Seventh

Ex: C m7



Play the root, the third key above it, and the second key below it.

Major Seventh

Ex: C maj 7



Play the root and the first key below it.

Diminished

Ex: C dim



Play the root and the sixth key above it.

MEMO

Normally, settings used for the Chord Intelligence function are selected, but there may be settings that are not used. You can also change the rules governing how chords are played. For more information, see "Changing How Chords Are Played and Specified (Arranger Config)" (p. 138).

MEMO

For more information about chord fingering, refer to the "Chord List" (p. 178).

■ Viewing Chord Fingerings (Chord Finder)

Whenever you are not sure how a certain chord is fingered, you can display the notes of the chord on the screen.

1. On the Basic screen, touch .



2. Touch the root of the chord you want to learn about.

The chord fingering appears on screen.

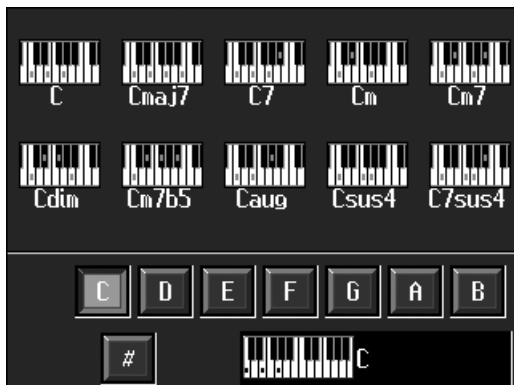

For example, if you wanted to see the fingering for a C# chord, you would touch <C>, then touch <#>.

Press the [Exit] button to go back to the Basic screen.