

# Rosemount™ 5408 and 5408:SIS Level Transmitters

Non-Contacting Radar



**HART**   
COMMUNICATION PROTOCOL

  
**EMERSON**

*PRELIMINARY*

# Contents

## Section 1: Introduction

1.1 Models covered .....	1
1.2 Using this manual .....	1
1.3 Product recycling/disposal .....	2

## Section 2: Transmitter Overview

2.1 Measurement principle .....	3
2.2 Process characteristics .....	4
2.2.1 Dielectric constant .....	4
2.2.2 Foam and turbulence .....	4
2.2.3 Condensation .....	4
2.3 Vessel characteristics .....	4
2.3.1 In-tank obstructions .....	4
2.3.2 Tank shape .....	5
2.4 Application examples .....	5
2.5 Components of the transmitter .....	7
2.6 System integration .....	8

## Section 3: Mechanical Installation

3.1 Safety messages .....	9
3.2 Review mounting considerations .....	10
3.2.1 Mounting position .....	10
3.2.2 Antenna size .....	11
3.2.3 Inclination of antenna .....	11
3.2.4 Non-metallic tanks .....	11
3.2.5 Beam width and beam angle .....	12
3.2.6 Nozzle requirements .....	13
3.2.7 Free space requirements .....	15
3.2.8 Installation in still pipe/chamber .....	16
3.2.9 Ball valve installation .....	17
3.3 Review mounting preparations .....	18
3.3.1 Assemble the segmented cone antenna .....	18
3.3.2 Shorten the extended cone antenna .....	20
3.4 Mount the cone antenna .....	21
3.4.1 Flanged version .....	22
3.4.2 Flanged version with air purge ring .....	23

3.4.3 Threaded version .....	25
3.4.4 Bracket mounting .....	31
3.4.5 Align transmitter head .....	34
3.5 Mount the parabolic antenna .....	36
3.5.1 Flanged version .....	37
3.5.2 Threaded version .....	38
3.5.3 Welded version .....	42
3.5.4 Adjust the inclination of the antenna .....	48
3.5.5 Connect the air purging .....	51
3.6 Adjust display orientation (optional) .....	52

## Section 4: Electrical Installation

4.1 Safety messages .....	53
4.2 Cable selection .....	54
4.3 Cable gland/conduit .....	54
4.4 Power supply .....	54
4.5 Hazardous areas .....	54
4.6 Wiring diagram .....	55
4.7 Grounding .....	55
4.7.1 Transmitter housing .....	55
4.7.2 Signal cable shield grounding .....	56
4.8 Wiring and power up .....	57
4.9 Optional devices .....	60
4.9.1 Rosemount 333 HART Tri-Loop™ .....	60

## Section 5: Configuration

5.1 Safety messages .....	61
5.2 Overview .....	62
5.3 Get started with your preferred configuration tool .....	62
5.3.1 Rosemount Radar Master .....	62
5.3.2 AMS Device Manager .....	63
5.3.3 Field Communicator .....	64
5.4 Configure device using Guided Setup .....	65
5.5 Verify Level .....	66
5.6 Establish multidrop communication .....	66
5.7 Use with the HART Tri-Loop .....	67

**Section 6: Operation**

6.1 LCD display screen messages.....	69
6.1.1 Startup screen sequence.....	69
6.1.2 Variable screens .....	70
6.2 Set up the LCD display.....	70
6.3 View measurement data.....	71
6.3.1 View current measurement values .....	71
6.3.2 Interpret measurement status bars.....	72
6.4 Check device status .....	72

**Section 7: Troubleshooting**

7.1 Safety messages.....	75
7.2 Diagnostic messages.....	76
7.3 Troubleshooting guide .....	82
7.4 Service and troubleshooting tools .....	87
7.4.1 Use the echo curve function .....	87
7.4.2 Manage disturbance echoes.....	90
7.4.3 Save and load configuration files .....	94
7.4.4 Restore to default settings .....	95
7.4.5 Calibrate analog out.....	95
7.4.6 Use the simulation mode .....	96
7.4.7 View input registers .....	96
7.4.8 View/edit holding registers.....	97
7.5 Write protect a transmitter .....	98
7.6 Application challenges .....	99
7.6.1 Handling disturbances at top of tank .....	99
7.6.2 Tracking of weak surface echoes close to tank bottom.....	100
7.6.3 Handling ghost echoes in still pipes .....	102
7.6.4 Handling strong double bounce echoes.....	103
7.7 Service support.....	104

**Section 8: Safety Instrumented Systems (4-20 mA only)**

8.1 Safety messages.....	105
8.2 Terms and definitions .....	106
8.3 Safety Instrumented System (SIS) certification .....	108
8.4 Safety certified identification.....	109
8.5 Installation.....	110
8.5.1 Measuring range .....	110

8.6	Configuration .....	110
8.6.1	Prerequisites .....	110
8.6.2	Configure device using Guided Setup .....	110
8.6.3	Set operational mode .....	111
8.6.4	Enable safety mode .....	111
8.6.5	Alarm and saturation levels .....	112
8.7	Site acceptance .....	112
8.8	Proof-testing .....	112
8.8.1	Overview .....	112
8.8.2	1-point level and analog output verification .....	114
8.8.3	2-point level and analog output verification .....	116
8.8.4	Analog output verification .....	118
8.8.5	Level deviation monitoring .....	118
8.8.6	Product repair .....	118
8.9	Specifications .....	119
8.10	SIS loop example .....	119

## Appendix A: Specifications and Reference Data

A.1	Performance specifications .....	121
A.1.1	General .....	121
A.1.2	Measuring range .....	121
A.1.3	Environment .....	122
A.2	Functional specifications .....	122
A.2.1	General .....	122
A.2.2	Display and configuration .....	123
A.2.3	4-20 mA HART (output code H) .....	123
A.2.4	Diagnostics .....	124
A.2.5	Process temperature and pressure rating .....	125
A.2.6	Temperature limits .....	125
A.2.7	Process sealing for flammable fluids .....	125
A.2.8	Flange rating .....	125
A.2.9	Air purging .....	126
A.2.10	System integration .....	126
A.3	Physical specifications .....	126
A.3.1	Material selection .....	126
A.3.2	Engineered solutions .....	127
A.3.3	Housing and enclosure .....	127
A.3.4	Tank connection .....	127

A.3.5 Flange dimensions .....	127
A.3.6 Antenna versions .....	127
A.3.7 Material exposed to tank atmosphere .....	127
A.3.8 Weights .....	128
A.4 Ordering information .....	129
A.5 Dimensional drawings.....	140
A.6 Standard flanges.....	143

## Appendix B: Product Certifications

B.1 European Directive Information .....	145
B.2 Telecommunication compliance.....	145
B.3 FCC .....	145
B.4 IC.....	145
B.5 Radio Equipment Directive (RED) 2014/53/EU.....	146
B.6 Installing Equipment in North America .....	146
B.7 USA.....	146
B.8 Canada .....	148
B.9 Europe .....	150
B.10 International.....	152
B.11 Approval drawings.....	153

## Appendix C: Configuration Parameters

C.1 Menu tree .....	160
C.2 Device setup .....	162
C.2.1 HART .....	162
C.2.2 Units .....	162
C.2.3 Analog output.....	163
C.2.4 Display .....	164
C.2.5 Security.....	164
C.2.6 Device Information.....	164
C.3 Level setup.....	165
C.3.1 Geometry.....	165
C.3.2 Environment .....	171
C.3.3 Volume.....	171
C.3.4 Scaled variable.....	172
C.3.5 Antenna .....	173
C.3.6 Advanced .....	174
C.4 Alert setup.....	178





---

# Rosemount™ 5408 and 5408:SIS Level Transmitters – Non-Contacting Radar

## NOTICE

Read this manual before working with the product. For personal and system safety, and for optimum product performance, make sure you thoroughly understand the contents before installing, using, or maintaining this product.

Within the United States, Emerson™ Process Management has two toll-free assistance numbers.

**Customer Central:**

Technical support, quoting, and order-related questions.

United States - 1-800-999-9307 (7:00 am to 7:00 pm CST)

Asia Pacific- 65 777 8211

Europe / Middle East / Africa - 49 (8153) 9390

**North American Response Center:**

Equipment service needs.

1-800-654-7768 (24 hours a day — includes Canada)

For equipment service or support needs outside the United States, contact your local Emerson Process Management representative.

---

**⚠ WARNING**

**Failure to follow safe installation and service guidelines could result in death or serious injury.**

- Make sure only qualified personnel perform the installation.

**Explosions could result in death or serious injury.**

- Verify that the operating environment of the transmitter is consistent with the appropriate hazardous locations certifications.
- Before connecting a Field Communicator in an explosive atmosphere, make sure the instruments in the loop are installed in accordance with intrinsically safe or non-incendive field wiring practices.
- Do not remove the transmitter covers in explosive atmospheres when the circuit is alive.
- Both transmitter covers must be fully engaged to meet explosion-proof requirements.

**Electrical shock can result in death or serious injury.**

- Avoid contact with the leads and terminals. High voltage that may be present on leads can cause electrical shock.
- Make sure the main power to the transmitter is off and the lines to any other external power source are disconnected or not powered while wiring the transmitter.

**Process leaks could result in death or serious injury.**

- Make sure that the transmitter is handled carefully. If the process seal is damaged, gas might escape from the tank.

**Any substitution of non-authorized parts or repair, other than exchanging the complete transmitter head or antenna assembly, may jeopardize safety and is prohibited.**

- Unauthorized changes to the product are strictly prohibited as they may unintentionally and unpredictably alter performance and jeopardize safety. Unauthorized changes that interfere with the integrity of the welds or flanges, such as making additional perforations, compromise product integrity and safety. Equipment ratings and certifications are no longer valid on any products that have been damaged or modified without the prior written permission of Emerson Process Management. Any continued use of product that has been damaged or modified without the written authorization is at the customer's sole risk and expense.

**⚠ WARNING**

WARNING – Substitution of components may impair Intrinsic Safety.

WARNING – To prevent ignition of flammable or combustible atmospheres, disconnect power before servicing.

WARNING – Potential electrostatic charging hazard – Wipe with a damp cloth.

WARNING – Open circuit before removing cover.

WARNING – Seal to be installed within 50 mm of the enclosure.

**▲ WARNING**

AVERTISSEMENT – La substitution de composants peut compromettre la sécurité intrinsèque.

AVERTISSEMENT – Ne pas ouvrir en cas de présence d'atmosphère explosive.

AVERTISSEMENT – Risque potentiel de charge électrostatique – Essuyer avec un chiffon humide.

AVERTISSEMENT – Un dispositif d'étanchéité doit être installé à 50mm du boîtier.

AVERTISSEMENT – Ouvrir le circuit avant d'enlever le couvercle.

---

**▲ CAUTION**



**Hot surfaces**

The flange and process seal may be hot at high process temperatures. Allow to cool before servicing.

---

**▲ CAUTION**

**The products described in this document are NOT designed for nuclear-qualified applications.**

- Using non-nuclear qualified products in applications that require nuclear-qualified hardware or products may cause inaccurate readings. For information on Rosemount nuclear-qualified products, contact your local Emerson Process Management Sales Representative.
-



---

# Section 1 Introduction

## 1.1 Models covered

The following point level detectors are covered by this manual:

- Rosemount 5408™ Level Transmitter
- Rosemount 5408:SIS Level Transmitter

## 1.2 Using this manual

The sections in this manual provide information on installing, operating, and maintaining the Rosemount 5408 and 5408:SIS Level Transmitters – Non-Contacting Radar. The sections are organized as follows:

[Section 2: Transmitter Overview](#) provides an introduction to theory of operation, a description of the transmitter, information on typical applications, and process characteristics.

[Section 3: Mechanical Installation](#) contains mechanical installation instructions.

[Section 4: Electrical Installation](#) contains electrical installation instructions.

[Section 5: Configuration](#) provides instructions on configuration of the transmitter.

[Section 6: Operation](#) contains operation and maintenance techniques.

[Section 7: Troubleshooting](#) provides troubleshooting techniques for the most common operating problems.

[Section 8: Safety Instrumented Systems \(4-20 mA only\)](#) contains identification, commissioning, maintenance, and operations information for safety-certified transmitter used in Safety Instrumented Systems (SIS) applications.

[Appendix A: Specifications and Reference Data](#) supplies reference and specification data, as well as ordering information.

[Appendix B: Product Certifications](#) contains safety approval information and approval drawings.

[Appendix C: Configuration Parameters](#) provides extended information about the configuration parameters.

## **1.3      Product recycling/disposal**

Recycling of equipment and packaging should be taken into consideration and disposed of in accordance with local and national legislation/regulations.

## Section 2 Transmitter Overview

Measurement principle .....	page 3
Process characteristics .....	page 4
Application examples .....	page 5
Components of the transmitter .....	page 7
System integration .....	page 8

### 2.1 Measurement principle

The Rosemount™ 5408 and 5408:SIS are two-wire transmitters for continuous level measurement of a broad range of liquids and slurries. It uses two-wire fast-sweep Frequency Modulated Continuous Wave (FMCW) technology.

The transmitter continuously emits signal sweeps with a constantly varying frequency towards the product surface. Since the transmitter continuously changes the frequency of the transmitted signal, there will be a difference in frequency between the transmitted and the reflected signals.

The frequency of the reflected signal is subtracted from the frequency of the signal transmitted at that moment, resulting in a low frequency signal which is proportional to the distance to the product surface. This signal is further processed to obtain fast, reliable, and highly accurate level measurements.

Figure 2-1. FMCW-method

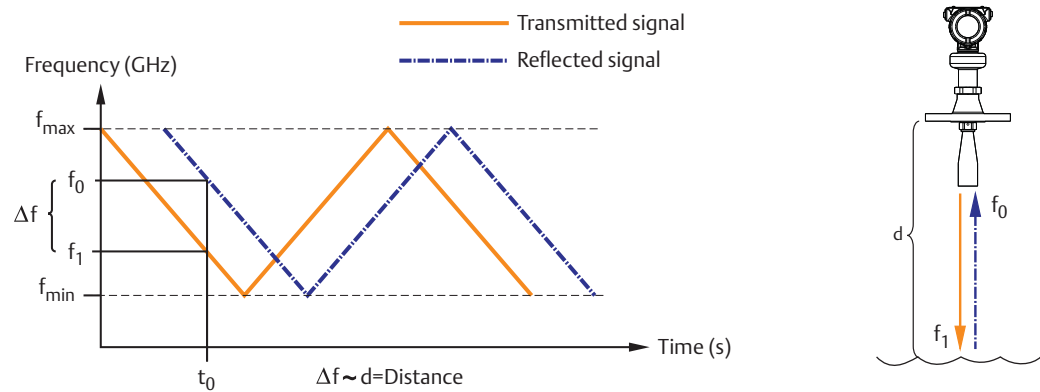

## 2.2 Process characteristics

### 2.2.1 Dielectric constant

A key parameter for measurement performance is reflectivity. A high dielectric constant of the media provides better reflection and enables a longer measuring range.

In addition to the dielectric constant, the measuring range depends on the microwave frequency, antenna size, and the process conditions (see [“Measuring range” on page 121](#)).

### 2.2.2 Foam and turbulence

Foaming liquids or turbulence may cause weak and varying surface echo amplitudes. The effects of turbulence are usually minor, but in the most challenging conditions, the transmitter may be mounted in a still pipe. In addition, measurement performance can be optimized by enabling the appropriate process conditions parameters, see [“Process conditions” on page 171](#).

Measurement in foamy applications depends largely on the foam properties. When the foam is light and airy, the actual product level is measured. For heavy and dense foam, the transmitter may measure the level of the foam’s upper surface. The Double Surface Handling function allows the user to select if the foam layer or product surface should be used as output.

### 2.2.3 Condensation

Generally, the radar signal is unaffected by condensation and low pressure steam. However, heavy condensation can effect the measurement. In such applications, air purging may be required to prevent clogging of the antenna.

In high temperature applications, it is recommended to insulate the tank nozzle. Insulation prevents the nozzle from becoming a cold spot, and thus reduces the amount of water build up and condensation on the antenna.

If the temperature in the tank is much higher than the ambient temperature (i.e. tank is heated and located in a cold area), it might be necessary to heat trace the nozzle in addition to the insulation.

## 2.3 Vessel characteristics

### 2.3.1 In-tank obstructions

The transmitter should be mounted so that objects such as heating coils, ladders, agitators and so on are not in the radar signal path. These objects may cause false echoes resulting in reduced measurement performance. However, the transmitter has built-in functions designed to reduce the influence from disturbing objects where such objects cannot be totally avoided.

Vertical and inclined structures cause minimal effect since the radar signal is scattered rather than directed back to the antenna.



## 2.3.2 Tank shape

The shape of the tank bottom affects the measurement signal when the product surface is close to the tank bottom. The transmitter has built-in functions which optimize measurement performance for various bottom shapes.

## 2.4 Application examples

The Rosemount 5408 and 5408:SIS are ideal for level measurements on a broad range of liquids and slurries. The transmitter is virtually unaffected by changing density, temperature, pressure, media dielectric, pH, and viscosity. Non-contacting radar level is ideal for harsh conditions such as corrosive and sticky media, or when internal tank obstructions are a limiting factor.

### Storage and buffer tanks

The Rosemount 5408 provides accurate and reliable level measurement for storage or buffer tanks for almost any liquid, e.g. oil, gas condensate, water, chemicals, etc.

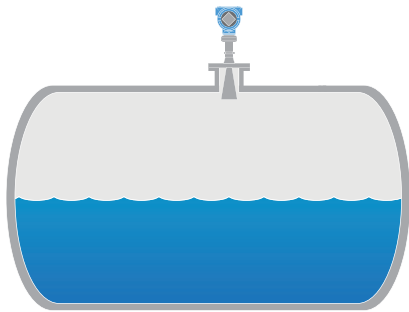

### Demanding environments

The Rosemount 5408 is a very suitable choice for the most challenging applications, such as reactors with varying process conditions and product turbulence created by agitators.

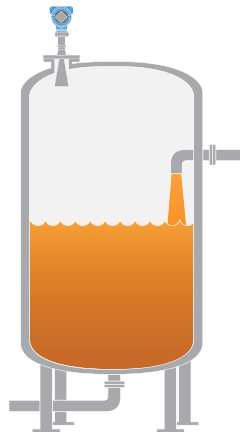

## Reactors and mixing tanks

Rosemount 5408 can help you withstand the rigors of reactor and mixing tanks. Easy to install and commission, it is also unaffected by virtually any fluid property change.

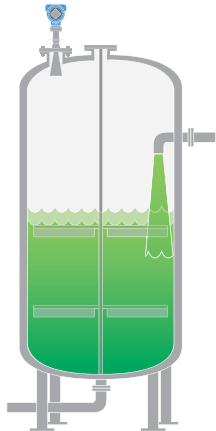

## Still pipe and chamber installations

The Rosemount 5408 is an excellent choice for level measurement in tanks with still pipes. It may also be used in chambers, but guided wave radar is generally the best fit for these applications. See [“Installation in still pipe/chamber”](#) on page 16 for installation guidelines.

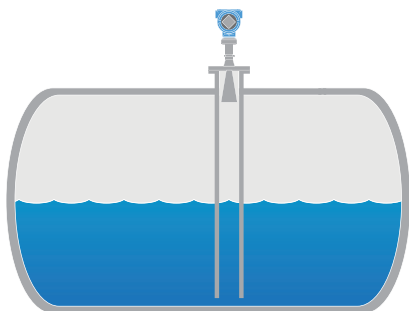

## 2.5 Components of the transmitter

Figure 2-2 shows the different components of the transmitter. There are different antenna types and sizes available for various applications.

Figure 2-2. Components

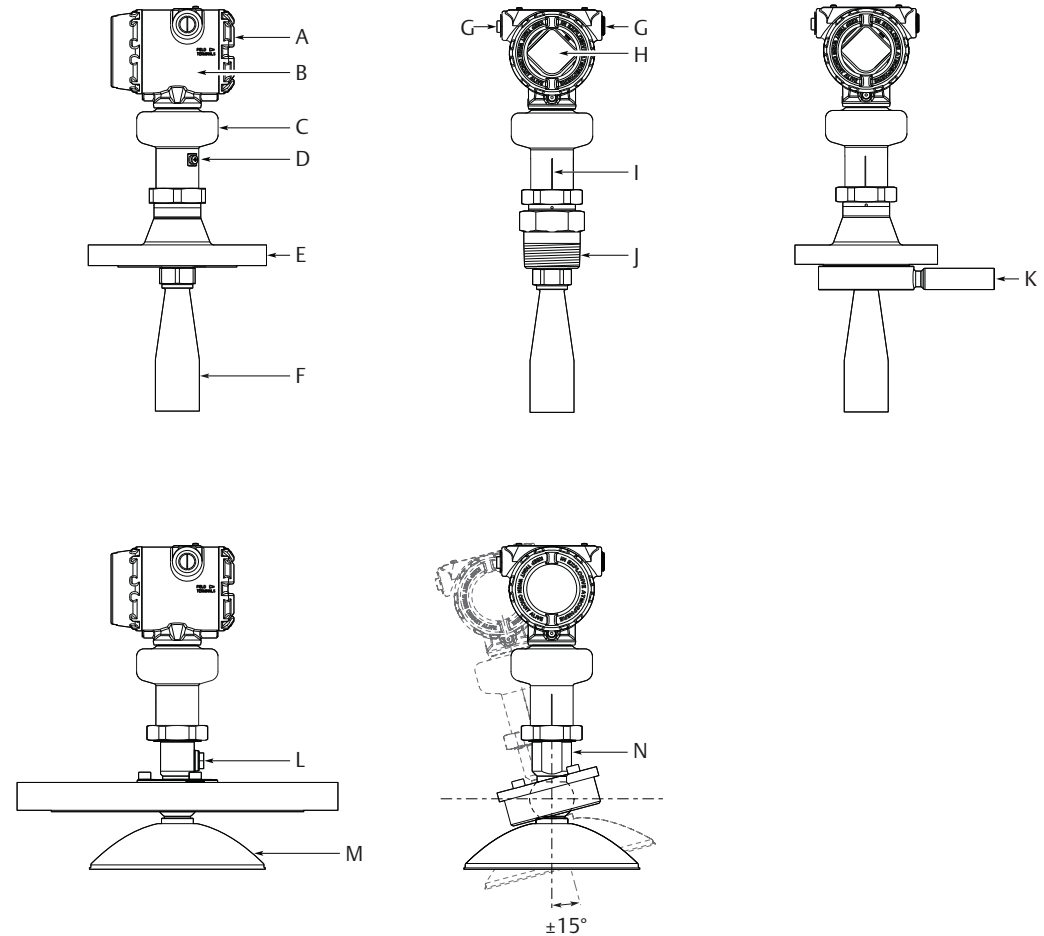

- A. Terminal compartment
- B. Transmitter housing (aluminum or stainless steel)
- C. Sensor module with signal processing electronics
- D. External ground screw
- E. Flanged process connection
- F. Cone antenna
- G. Two cable/conduit entries  
( $\frac{1}{2}$ -14 NPT, M20 x 1.5 or G1/2)  
Optional adapters: eurofast® and minifast®
- H. LCD display (optional)
- I. Alignment marker (one per side)
- J. Threaded process connection (NPT or BSPP (G))
- K. Air purge ring (option code PC1 for cone antenna)
- L. Integrated air purge connection
- M. Parabolic antenna
- N. Parabolic antenna with swivel mount

## 2.6 System integration

The transmitter is loop-powered, and uses the same two wires for power supply and output signal. The output is a 4-20 mA analog signal superimposed with a digital HART® signal. The transmitter can be configured for either HART Revision 6 (default) or 7 (option code HR7). The HART Revision can be switched in field.

By using the optional Rosemount 333 HART Tri-Loop™, the HART signal can be converted up to three additional 4-20 mA analog signals. With the HART protocol, multidrop configuration is possible. In this case, communication is restricted to digital, since current is fixed to the 4 mA minimum value.

The transmitter can be combined with the Emerson™ Wireless 775 THUM™ Adapter to wirelessly communicate HART data with IEC 62591 (*WirelessHART*®) technology. In addition, the transmitter can be connected to a Rosemount 751 Field Signal Indicator, or it can be equipped with an LCD display.

The transmitter can easily be configured by using a PC with the Rosemount Radar Master software (running in Instrument Inspector™), a Field Communicator, the AMS™ Suite: Intelligent Device Manager, or any other Device Descriptor (DD) or Field Device Integration (FDI) compatible host system.

The Rosemount 5408 and 5408:SIS are compliant to the NAMUR NE 107 Field Diagnostics for standardized device diagnostic information.

**Figure 2-3. System Architecture**

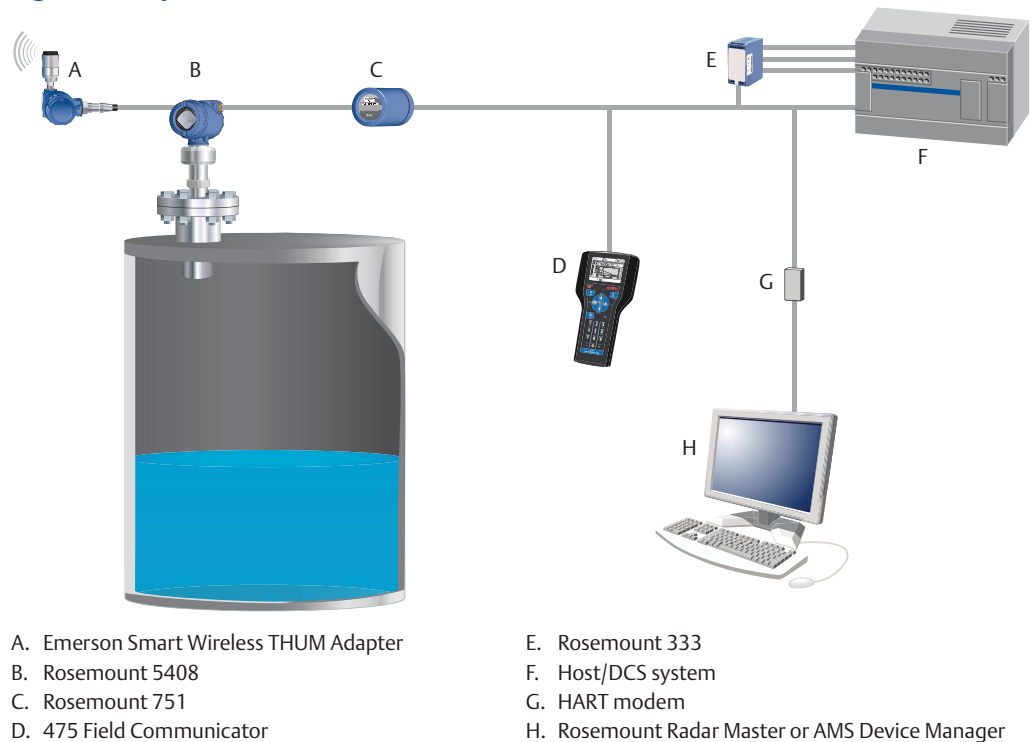

---

## Section 3 Mechanical Installation

---

Safety messages .....	page 9
Review mounting considerations .....	page 10
Review mounting preparations .....	page 18
Mount the cone antenna .....	page 21
Mount the parabolic antenna .....	page 36
Adjust display orientation (optional) .....	page 52

---

### 3.1 Safety messages

Procedures and instructions in this section may require special precautions to ensure the safety of the personnel performing the operation. Information that raises potential safety issues is indicated by a warning symbol (  ). Refer to the following safety messages before performing an operation preceded by this symbol.

#### WARNING

**Failure to follow safe installation and service guidelines could result in death or serious injury.**

- Make sure only qualified personnel perform the installation.

**Process leaks could result in death or serious injury.**

- Make sure that the transmitter is handled carefully. If the process seal is damaged, gas might escape from the tank.

**Explosions could result in death or serious injury.**

- Verify that the operating environment of the transmitter is consistent with the appropriate hazardous locations certifications.
-

## 3.2 Review mounting considerations

Before installing the transmitter, consider recommendations for mounting position, sufficient free space, nozzle requirements, etc.

### 3.2.1 Mounting position

When finding an appropriate location on the tank for the transmitter, the conditions of the tank must be carefully considered.

Consider the following guidelines when mounting the transmitter:

- For optimal performance, the transmitter should be installed in locations with a clear and unobstructed view of the product surface.
- Keep a distance of at least 8 in. (200 mm) distance to the tank wall.
- The optimal location is usually  $\frac{1}{4}$  of the tank diameter.
- Do not install the transmitter in the center of the tank.
- Do not mount close to or above the inlet stream.
- Multiple Rosemount™ 5408 and 5408:SIS Level Transmitters can be used in the same tank without interfering with each other.

Figure 3-1. Mounting Position

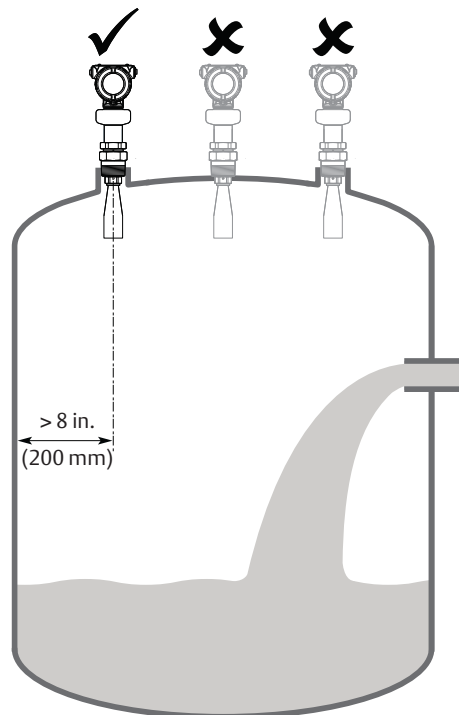

### 3.2.2 Antenna size

Choose as large antenna diameter as possible. A larger receiving area concentrates the radar beam and ensures maximum antenna gain. Increased antenna gain permits greater margin for weak surface echoes.

In addition, a larger antenna results in a smaller beam angle and thereby, less interference from any internal structures in the tank.

### 3.2.3 Inclination of antenna

Ensure the antenna is aligned vertically to the product surface for best measuring performance. The parabolic antenna comes with swivel connection that adjusts for angled tank roofs.

**Figure 3-2. Inclination**

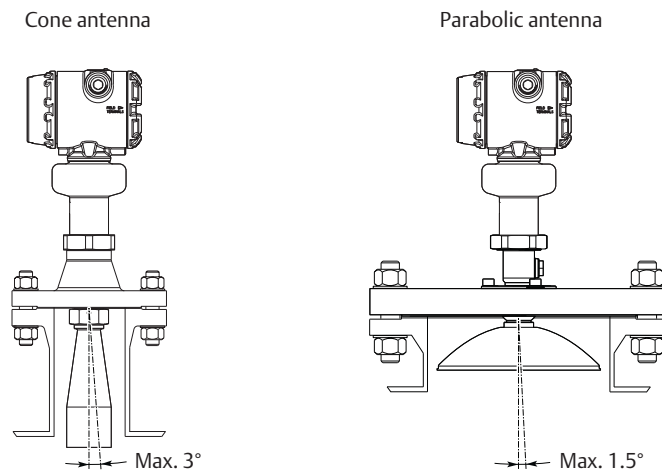

### 3.2.4 Non-metallic tanks

The walls in non-metallic tanks can be invisible to the radar signal, so nearby objects outside the tank may cause disturbing radar echoes. Wherever possible, the transmitter should be positioned so that objects close to the tank are kept outside the signal beam.

### 3.2.5 Beam width and beam angle

The transmitter should be mounted with as few internal structures as possible within the signal beam. Refer to [Table 3-1](#) for beam angle and [Table 3-2](#) for beam width at different distances.

**Figure 3-3. Beam Angle and Beam Width**

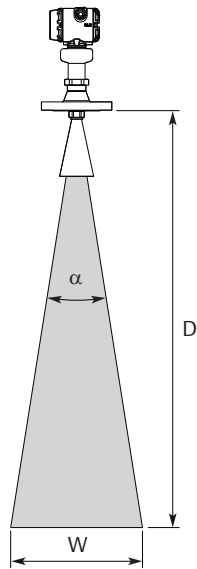

**Table 3-1. Beam Angle**

Antenna size	Beam angle ( $\alpha$ )
2-in. cone	18°
3-in. cone	14°
4-in. cone	10°
Parabolic	4.5°

**Table 3-2. Beam Width**

Distance (D), ft (m)	Beam width (W), ft (m)			
	2-in. cone	3-in. cone	4-in. cone	Parabolic
16 (5)	5.2 (1.6)	4.0 (1.2)	2.9 (0.9)	1.3 (0.4)
33 (10)	10.4 (3.2)	8.1 (2.5)	5.7 (1.8)	2.6 (0.8)
49 (15)	15.6 (4.8)	12.1 (3.7)	8.6 (2.6)	3.9 (1.2)
66 (20)	20.8 (6.3)	16.1 (4.9)	11.5 (3.5)	5.2 (1.6)
82 (25)	26.0 (7.9)	20.1 (6.1)	14.3 (4.4)	6.4 (2.0)
98 (30)	31.2 (9.5)	24.2 (7.4)	17.2 (5.3)	7.7 (2.4)
131 (40)	41.6 (12.7)	32.2 (9.8)	23.0 (7.0)	10.3 (3.1)



### 3.2.6 Nozzle requirements

In order to allow the microwaves to propagate undisturbed, the nozzle dimensions should be kept within the specified limits as given in [Table 3-3](#) and [Table 3-4](#).

#### Cone antenna

For best performance, the cone antenna should extend at least 0.4 in. (10 mm) below the nozzle. If required, use the extended cone antenna versions (option code S1 or S2).

However, the antenna can be recessed in smooth nozzles up to 4 ft (1.2 m). Note that if the inside of the nozzle has irregularities (e.g. due to bad welding, rust or deposit), then use the extend cone antenna.

**Figure 3-4. Mounting of the Cone Antenna**

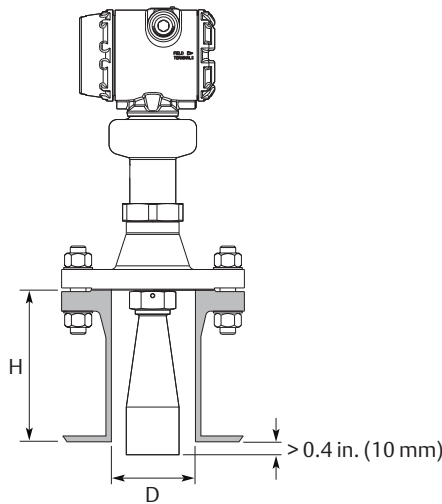

**Table 3-3. Nozzle Requirements for Cone Antenna, in Inches (Millimeters)**

Antenna size	Minimum nozzle diameter (D) <sup>(1)</sup>	Maximum nozzle height (H) <sup>(2)(3)</sup>	
		SST cone	SST cone with air purge ring (code PC1)
2-in. (DN50)	1.94 (49.3)		
3-in. (DN80)	2.80 (71.0)		
4-in. (DN100)	3.78 (96.0)		

1. The antennas are sized to fit within schedule 80 or lower pipes.
2. The values are valid for cone antennas without antenna extension.
3. The cone antenna can be recessed in smooth nozzles up to 4 ft (1.2 m), but note that the accuracy may be reduced in the region close to the nozzle. If this is not acceptable, use the extended cone antenna versions (option code S1 or S2).

## Parabolic antenna

See Table 3-4 for nozzle height recommendations at different inclination angle.

**Figure 3-5. Mounting of the Parabolic Antenna**

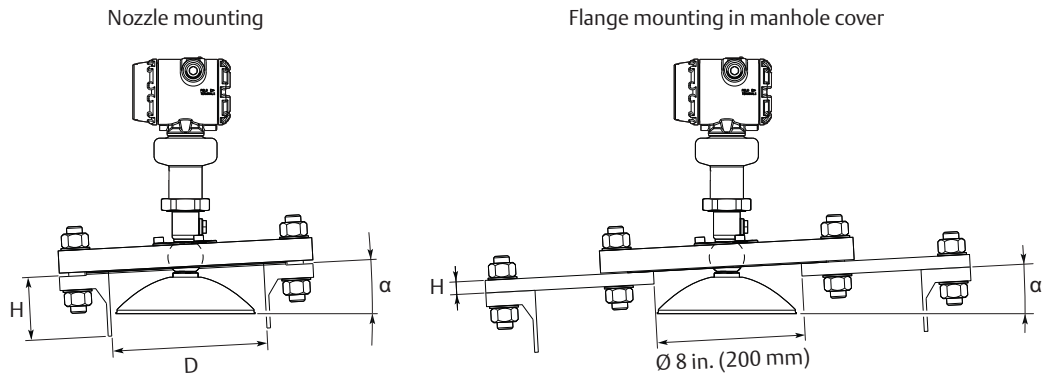

**Table 3-4. Nozzle Requirements for Parabolic Antenna**

Nozzle size (D)	Inclination angle ( $\alpha$ )	Maximum nozzle height (H), in. (mm) <sup>(1)</sup>
Pipe schedule std, Ø 8 in. (200 mm)	0°	5.9 (150)
	3°	5.5 (140)
	6°	1.6 (40)
	9°	1.2 (30)
	12°	1.0 (25)
	15°	0.6 (15)
Pipe schedule std, Ø10 in. (250 mm)	0°	8.0 (200)
	3°	8.0 (200)
	6°	8.0 (200)
	9°	8.0 (200)
	12°	5.9 (150)
	15°	4.3 (110)

1. Note that the inside of the nozzle must be smooth (i.e. avoid bad welding, rust or deposit).

### 3.2.7 Free space requirements

If the transmitter is mounted close to a wall or other tank obstructions such as heating coils and ladders, noise might appear in the measurement signal. Therefore the following minimum clearance, according to Table 3-5, must be maintained.

For easy access to the transmitter, mount it with sufficient service space (see Table 3-5).

Figure 3-6. Free Space Requirements

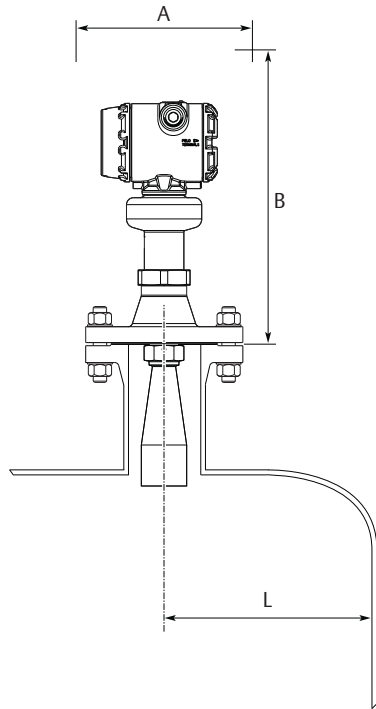

Table 3-5. Free Space Requirements

Free space requirements		Distance, in. (mm)
Service space width (A)		20 (500)
Service space height (B)		24 (600)
Distance to tank wall (L)	Minimum	8 (200)
	Recommended	1/4 of the tank diameter

### 3.2.8 Installation in still pipe/chamber

Installation in still pipe/chamber is recommended for tanks where surface conditions may be extremely turbulent. By using a pipe, foam or turbulence is reduced. All cone antenna sizes can be used for still pipe/chamber installations. Consider the following still pipe requirements:

#### Pipe

- Pipes should be an all-metal material.
- Pipe should have a constant inside diameter.
- The inner surface must be smooth and clear of any rough edges. (Smooth pipe joints are acceptable, but may reduce accuracy.)
- The end of the pipe must extend beyond the zero level.

#### Holes<sup>(1)</sup>

- Minimum hole diameter is 0.25 in. (6 mm).
- Maximum hole diameter should not exceed 10% of the pipe diameter (D).
- Minimum distance between holes is 6 in. (150 mm).
- Holes should be drilled on one side only and deburred.
- Drill one hole above maximum product surface.

#### Antenna

- The gap between cone antenna and still pipe is limited to 0.2 in. (5 mm). If required, order an oversized antenna and cut on location.

Figure 3-7. Still Pipe Requirements

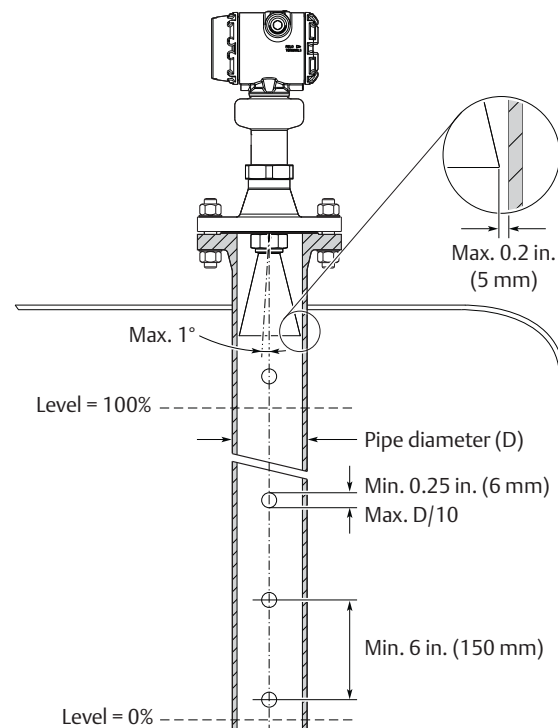

1. For guidelines on slotted pipes, consult your local Emerson Automation Solutions representative.

Consider the following chamber requirements:

- Pipes should be an all-metal material.
- Pipe should have a constant inside diameter.
- Inlet pipes should not protrude into the inside of the stand pipe.
- The inner surface must be smooth and clear of any rough edges. (Smooth pipe joints are acceptable, but may reduce accuracy.)
- The gap between cone antenna and stand pipe is limited to 0.2 in. (5 mm). If required, order an oversized antenna and cut on location.

**Figure 3-8. Chamber Requirements**

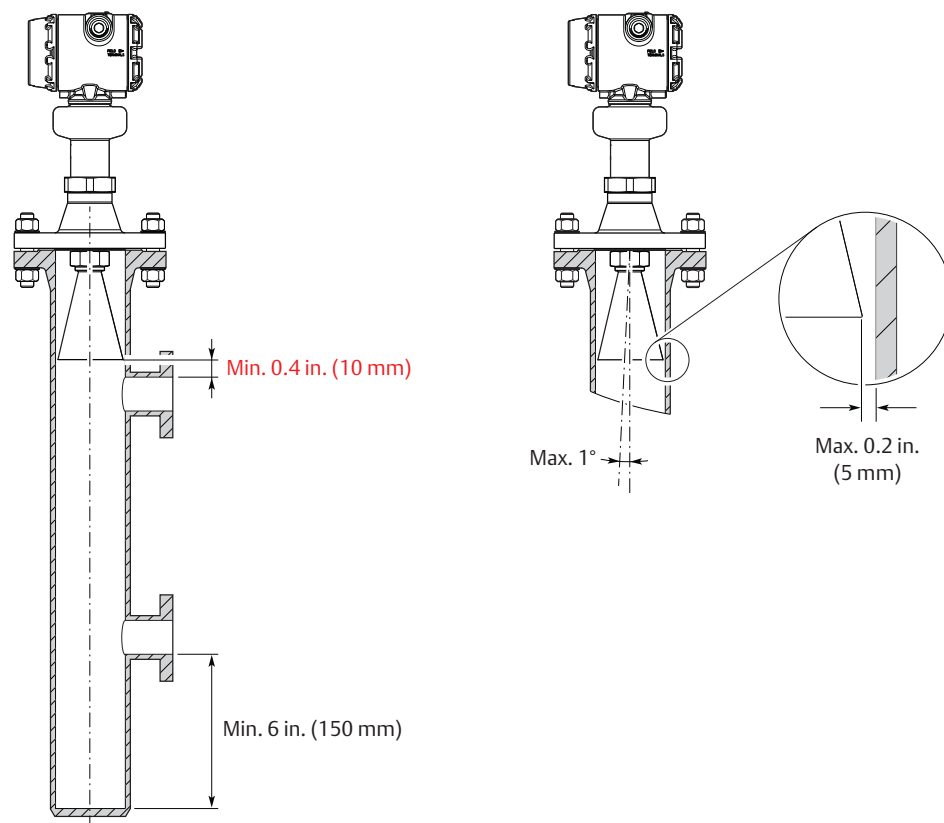

For more information and installation requirements, refer to the Guidelines for Choosing and Installing Radar in Stilling Wells and Bypass Chambers [Technical Note](#).

### 3.2.9 Ball valve installation

The transmitter can be isolated from the process by using a valve:

- Use a full-port ball valve.
- Ensure there is no edge between the ball valve and the nozzle or still pipe, the inside should be smooth.
- Valves can be combined with still pipe.

## 3.3 Review mounting preparations

### 3.3.1 Assemble the segmented cone antenna

This section applies to the segmented cone antenna (option code S2). Use only one segment; the total antenna length should not exceed 47.2 in. (1200 mm).

To determine the antenna length, follow the guidelines in section “Nozzle requirements” on page 13.

1. Insert the segment into the cone antenna until it bottoms.

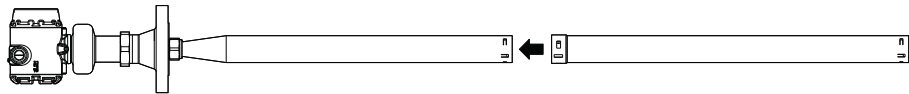

2. Mark where to cut the segment.

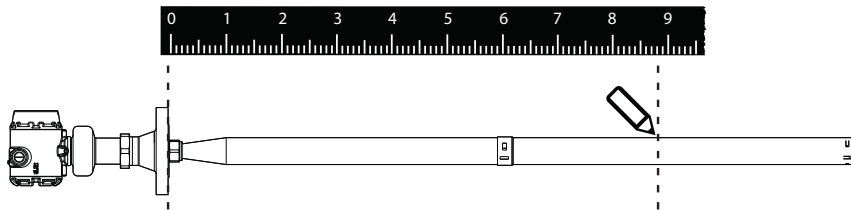

3. Cut the extension at the marking.

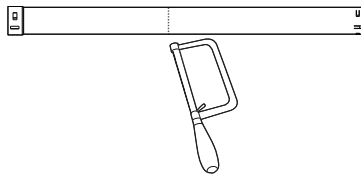

4. Remove any burrs.

5. Insert the segment into the cone antenna until it bottoms.

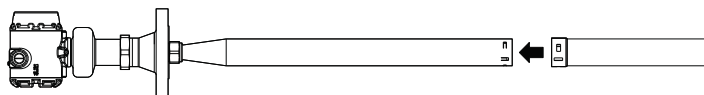

6. Secure the segment to the antenna.

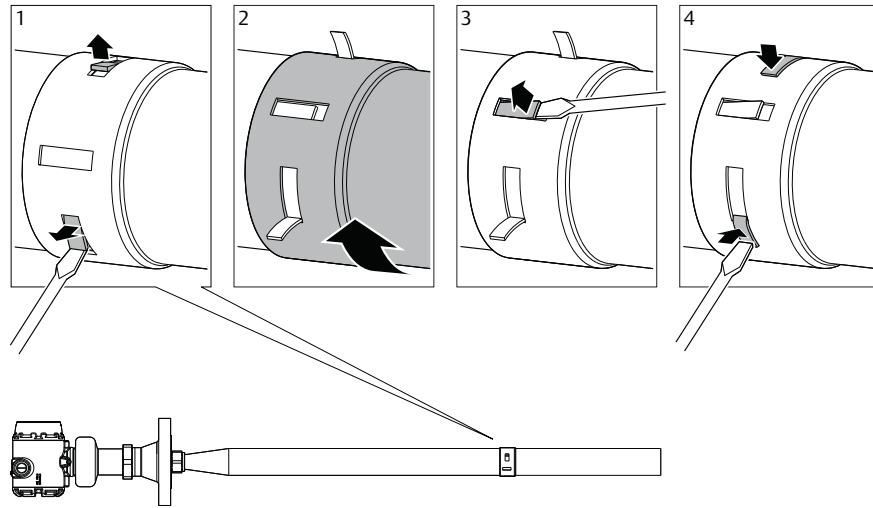

7. Measure the Antenna Extension Length (L).

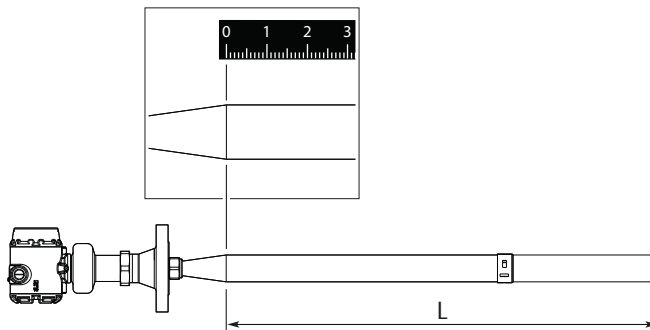

8. Update the transmitter configuration to the new Antenna Extension Length (L).

Rosemount Radar Master:

- Under *Configure*, select **Level Setup > Antenna**.

AMS Device Manager and  
Field Communicator:

- From the *Home* screen, select **Configure > Manual Setup > Level Setup > Antenna**.

### 3.3.2 Shorten the extended cone antenna

This section only applies to the extended cone antenna (option code S1).

To determine the antenna length, follow the guidelines in section “Nozzle requirements” on page 13.

1. Mark where to cut the antenna.

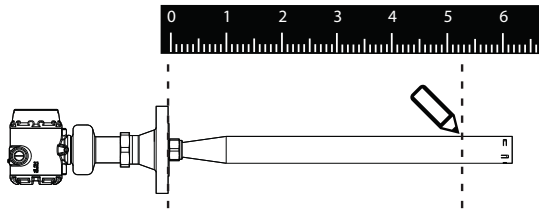

2. Cut the antenna at the marking.

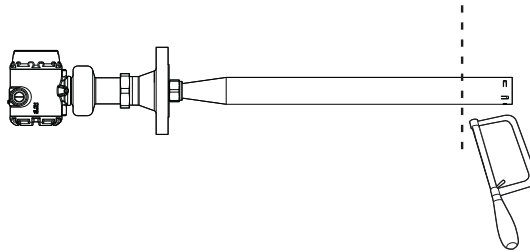

3. Remove any burrs.
4. Measure the Antenna Extension Length (L).

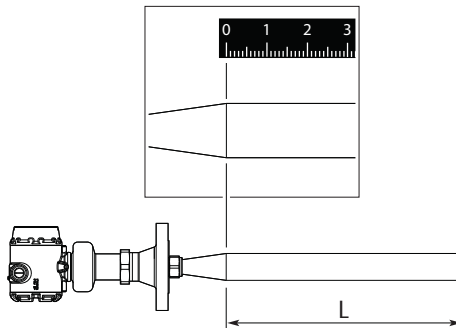

5. Update the transmitter configuration to the new Antenna Extension Length (L).

Rosemount Radar Master:

- Under *Configure*, select **Level Setup > Antenna**.

AMS Device Manager and  
Field Communicator:

- From the *Home* screen, select **Configure > Manual Setup > Level Setup > Antenna**.



### 3.4 Mount the cone antenna

Figure 3-9. Overview

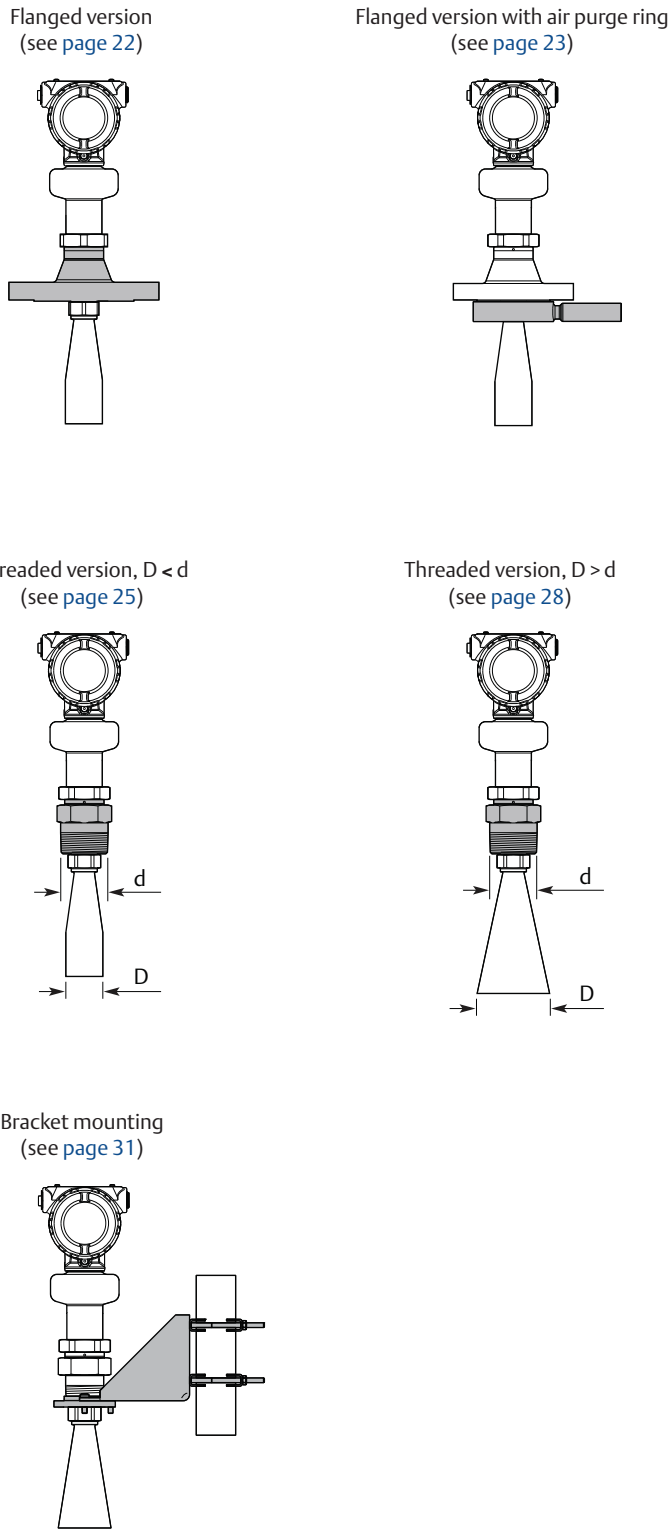

### 3.4.1 Flanged version

1. Lower transmitter with antenna and flange into the nozzle.

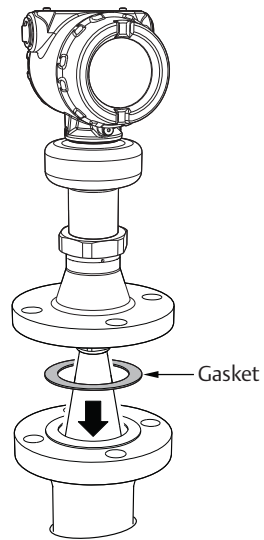

2. Tighten bolts and nuts with sufficient torque for the flange and gasket choice.

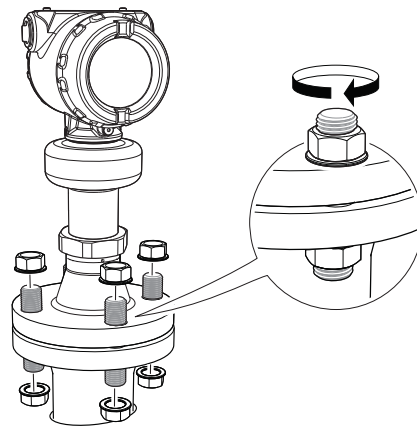

3. Align the transmitter head (see [page 34](#)).

### 3.4.2 Flanged version with air purge ring

1. Place a suitable gasket on the tank flange.

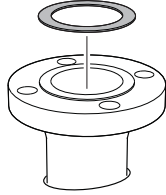

2. Place the purge ring over the gasket.

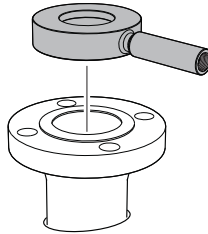

3. Place a suitable gasket over the purge ring.

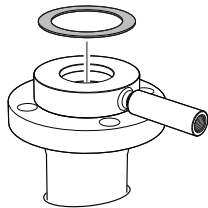

4. Lower transmitter with antenna and flange into the nozzle.

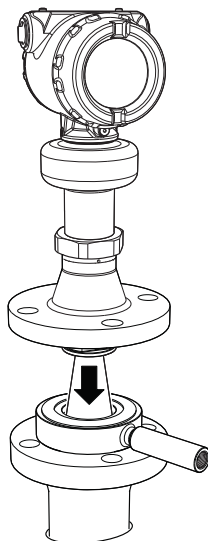

5. Tighten bolts and nuts with sufficient torque for the flange and gasket choice.

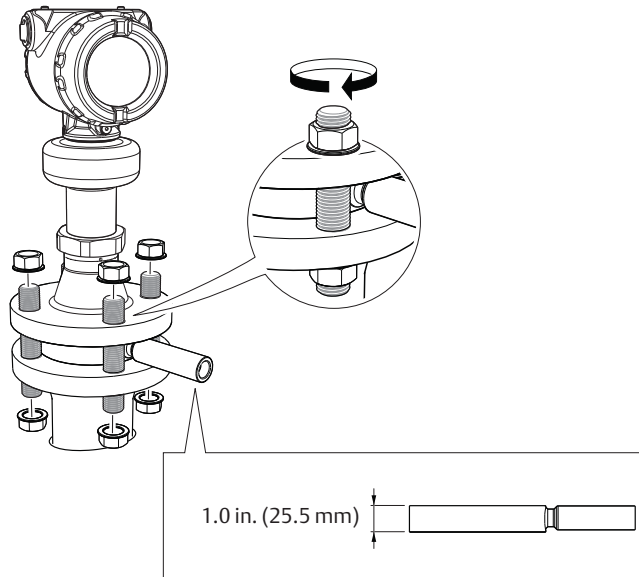

6. Connect the air purging system.

Use thread sealant or suitable gasket according to your site procedures.

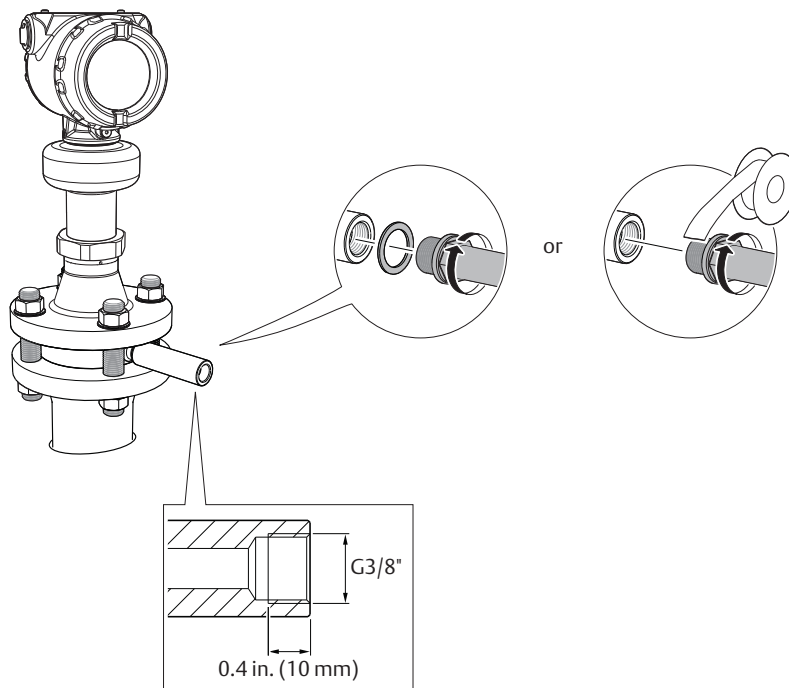

7. Align the transmitter head (see [page 34](#)).

## 3.4.3 Threaded version

**Antenna diameter (D) < Thread diameter (d)****Flanged tank connection**

1. Place a suitable gasket on the tank flange.

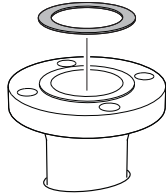

2. Place the customer supplied flange over the gasket.

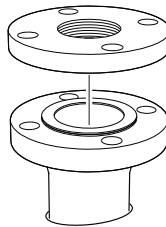

3. Tighten the bolts and nuts with sufficient torque for the flange and gasket choice.

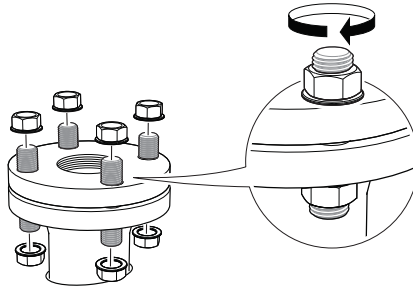

4. Apply anti-seize paste or PTFE tape on threads according to your site procedures.

⚠ Gasket may be used as a sealant for adapters with 1½ or 2-in. BSPP (G) threads.

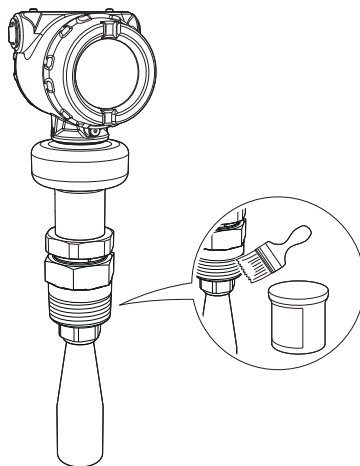

5. Lower transmitter with antenna and flange into the nozzle.

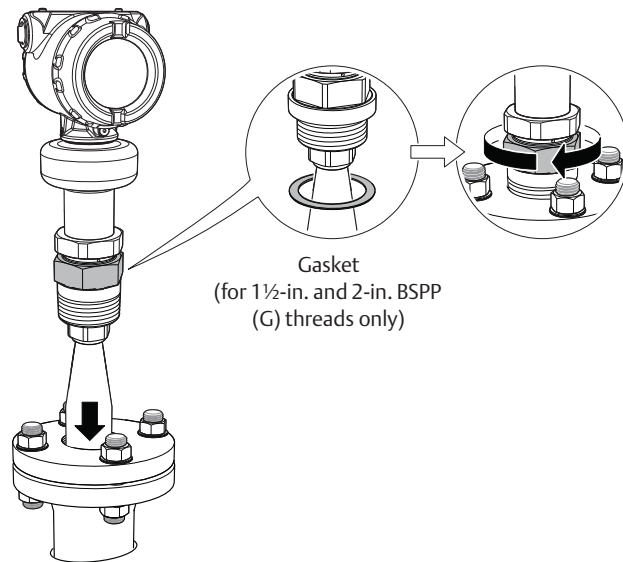

6. Align the transmitter head (see [page 34](#)).

### Threaded tank connection

1. Apply anti-seize paste or PTFE tape on threads according to your site procedures.  
 Gasket may be used as a sealant for adapters with 1½ or 2-in. BSPP (G) threads.

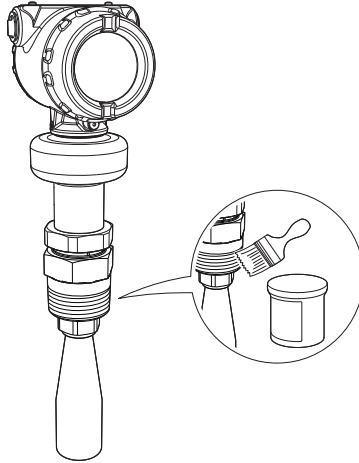

2. Mount the transmitter on tank.

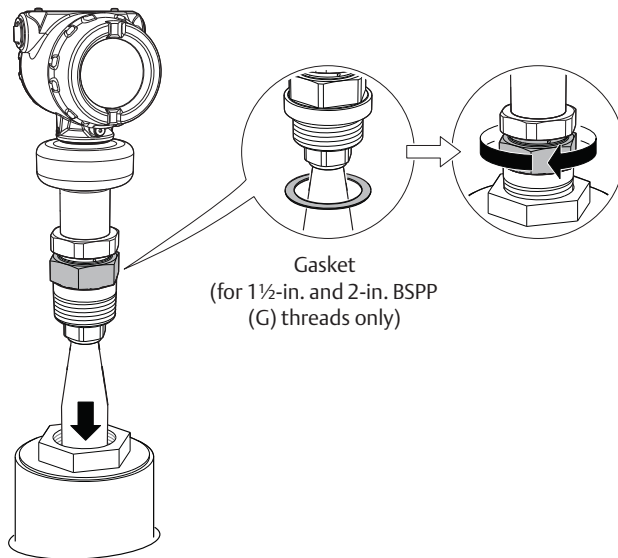

3. Align the transmitter head (see [page 34](#)).

### Antenna diameter (D) > Thread diameter (d)

1. Unscrew and remove the antenna.

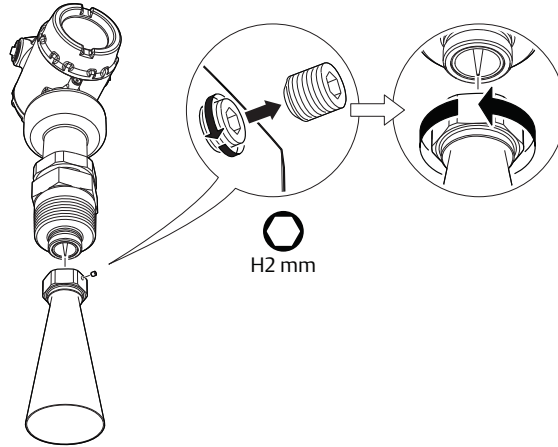

**Note**

Do not scratch the microwave launcher. The microwave launcher is sensitive to mechanical impacts.

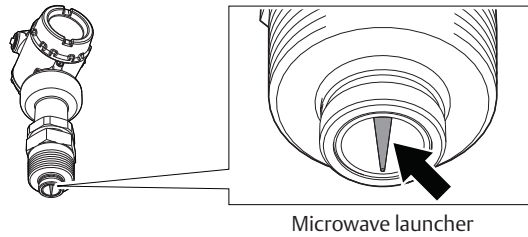

2. Apply anti-seize paste or PTFE tape on threads according to your site procedures.

⚠ Gasket may be used as a sealant for adapters with 1½ or 2-in. BSPP (G) threads.

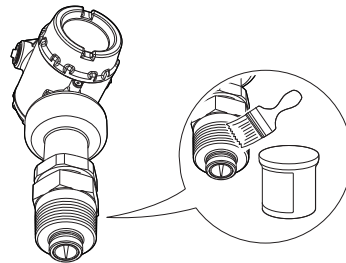



3. Mount the adapter on the customer supplied flange.

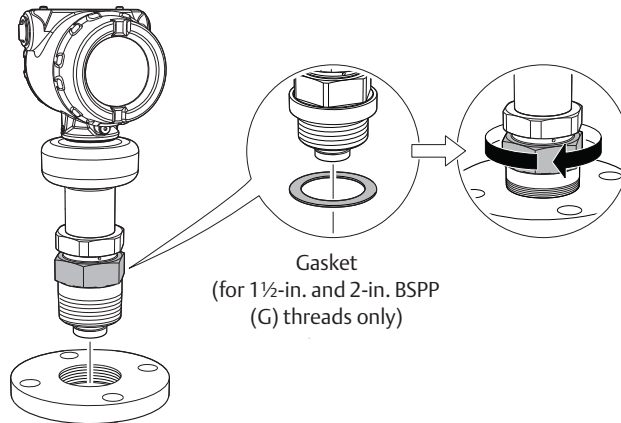

4. Mount the antenna.

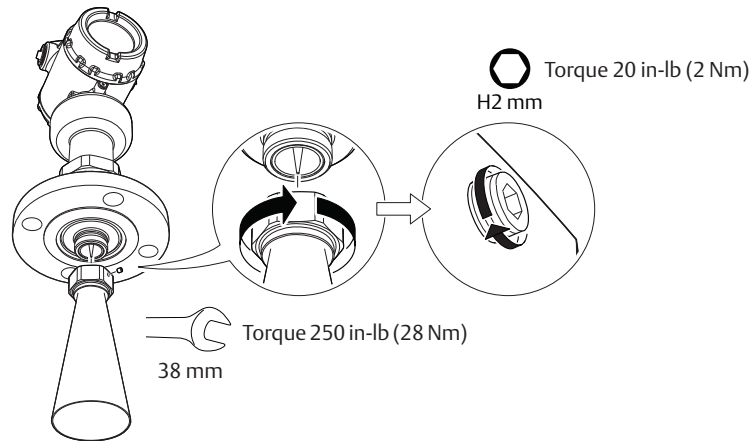

**Note**

Visually inspect the microwave launcher for damage and dirt. See [page 28](#).

5. Lower transmitter with antenna and flange into the nozzle.

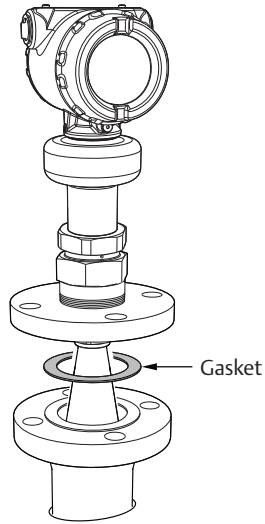

6. Tighten the bolts and nuts with sufficient torque for the flange and gasket choice.

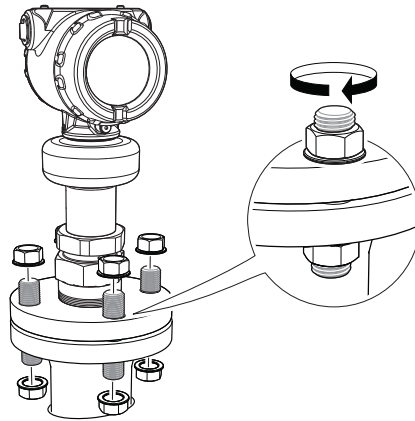

7. Screw the adapter until it is properly tightened.

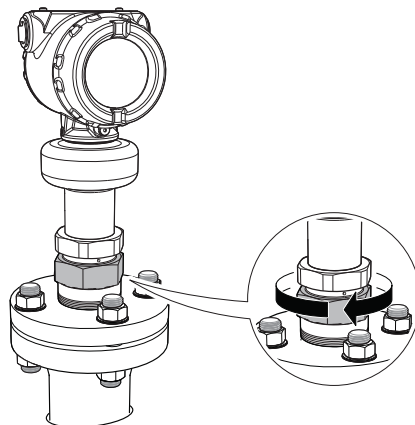

8. Align the transmitter head (see [page 34](#)).

### 3.4.4 Bracket mounting

1. Mount the bracket to the pipe/wall.

On pipe:

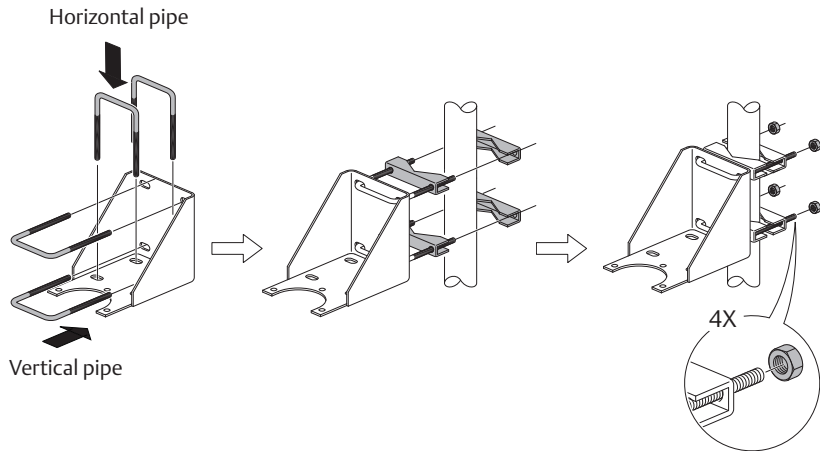

On wall:

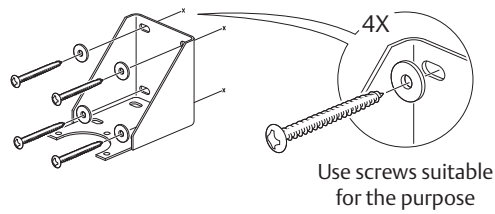

2. Mount the holder to the bracket.

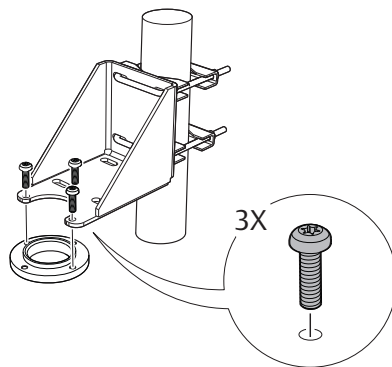

3. Unscrew and remove the antenna.

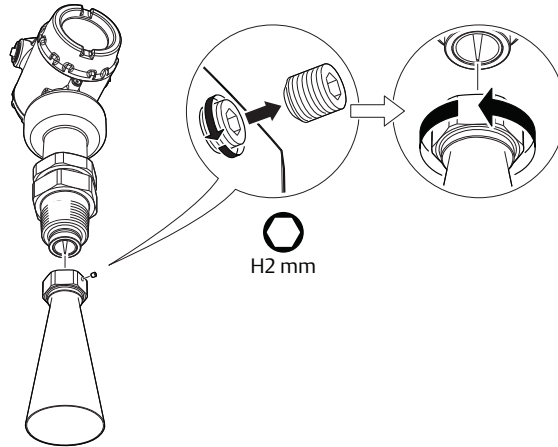

**Note**

Do not scratch the microwave launcher. The microwave launcher is sensitive to mechanical impacts.

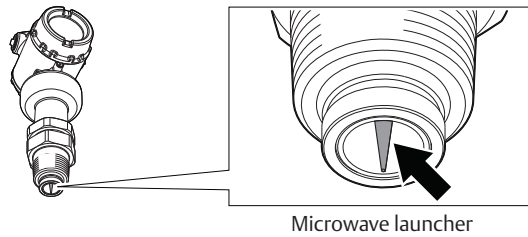

4. Screw the transmitter into the holder.

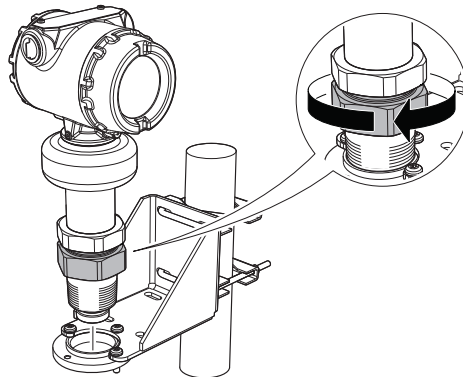

5. Mount the antenna.

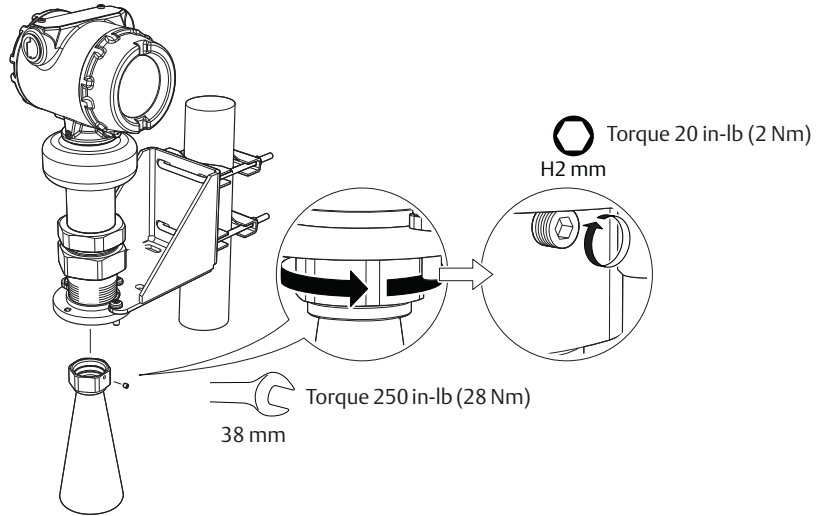

6. Align the transmitter head (see [page 34](#)).

### 3.4.5 Align transmitter head

#### Open tank

Align the marking on sensor module either toward or along the tank wall.

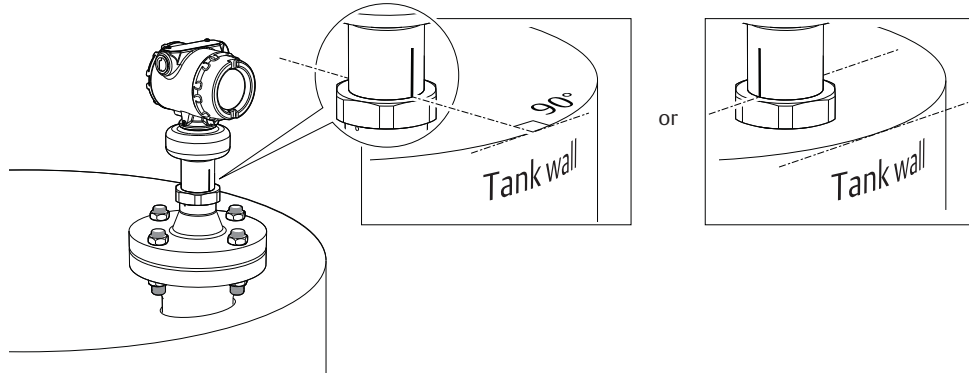

#### Still pipe

Align the external ground screw toward the holes of the still pipe.

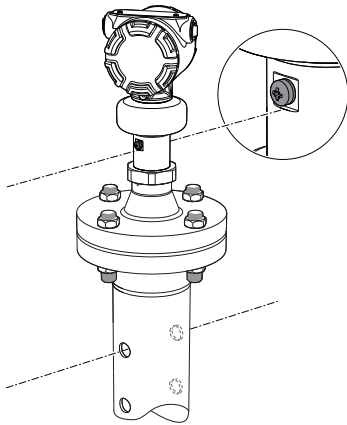

#### Chamber

Align the external ground screw toward the process connections.

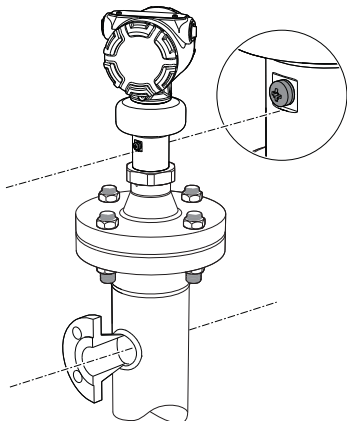

## Procedure

1. Loosen the nut slightly and turn the transmitter.

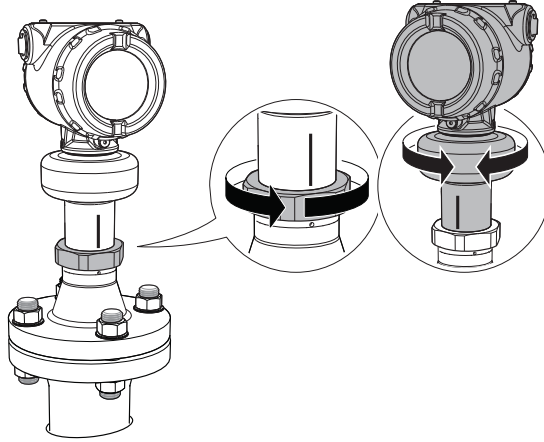

2. Verify the transmitter head is properly aligned (see [page 52](#) for direction).
3. Tighten the nut.

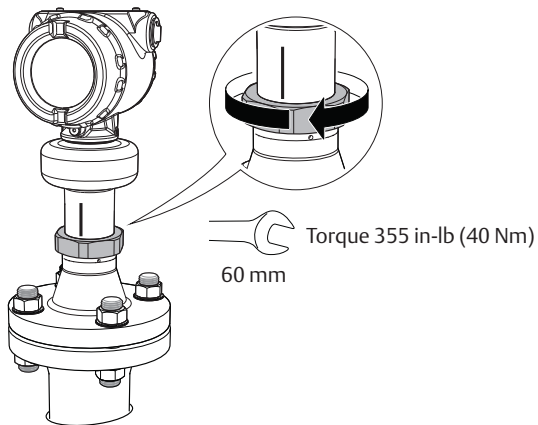

## 3.5 Mount the parabolic antenna

Figure 3-10. Overview

Flanged version  
(see page 37)

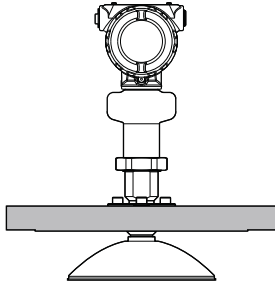

Threaded version  
(see page 38)

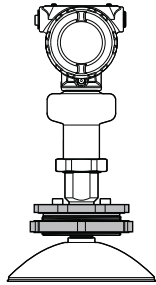

Welded version  
(see page 42)

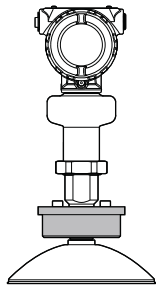



### 3.5.1 Flanged version

1. Lower the flange and antenna assembly into the nozzle.

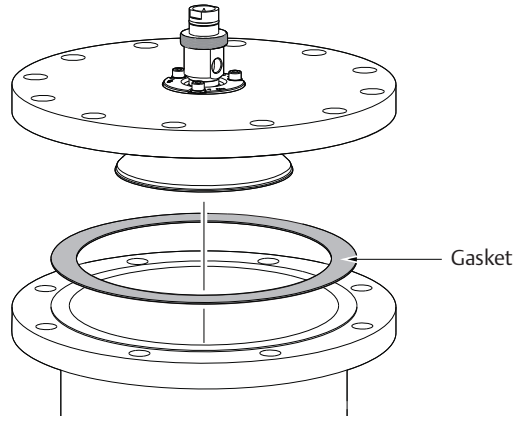

2. Tighten the bolts and nuts with sufficient torque for the flange and gasket choice.

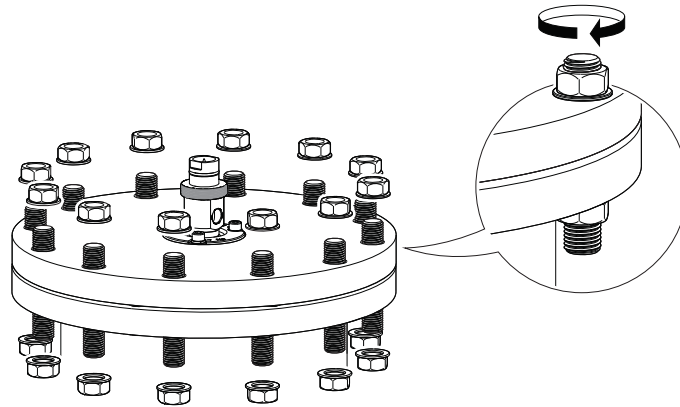

3. Adjust the inclination of the antenna (see [page 48](#)).
4. Connect the air purging system (see [page 51](#)).

### 3.5.2 Threaded version

Figure 3-11. Components

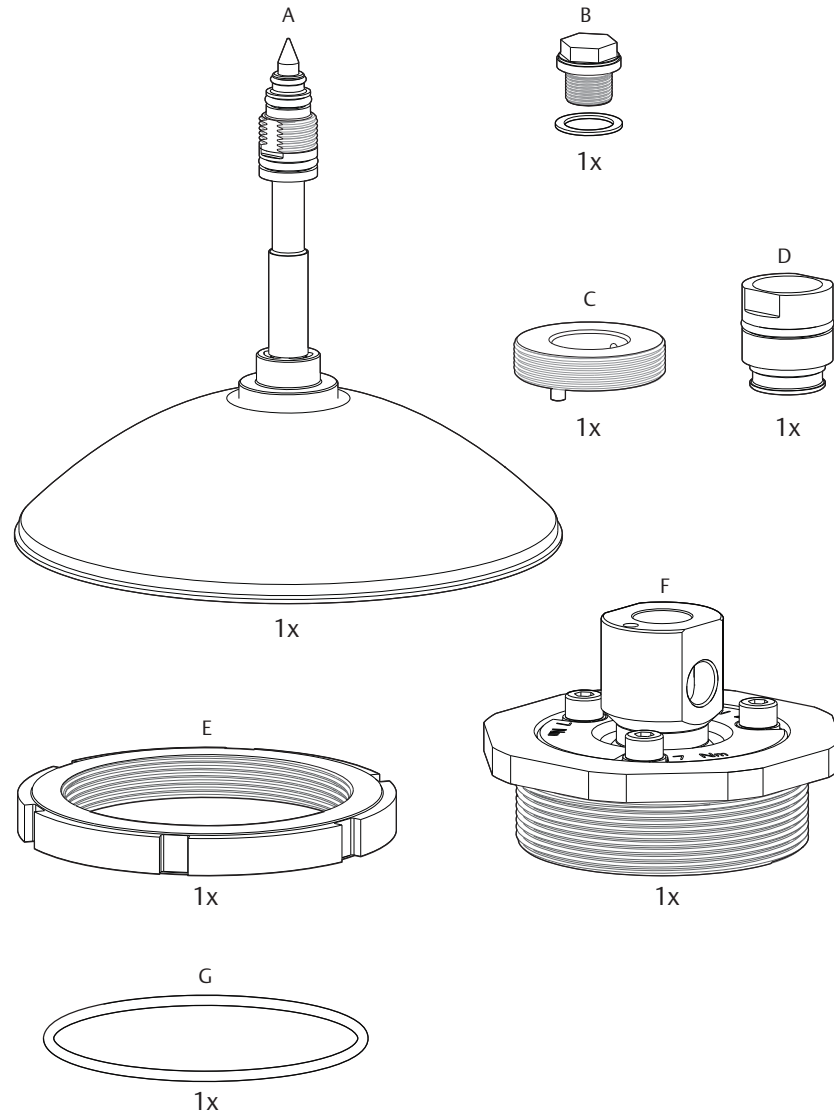

- A. Antenna
- B. Purge plug kit (optional with order)  
P/N 05400-1200-0001
- C. Threaded sleeve
- D. M20 adapter
- E. Lock nut G 3½" (optional with order)  
P/N 05400-1200-0002
- F. Antenna adapter with ball joint
- G. O-ring

### Procedure

1. Remove the lock nut (if applicable).

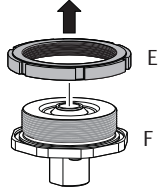

2. Mount the O-ring.

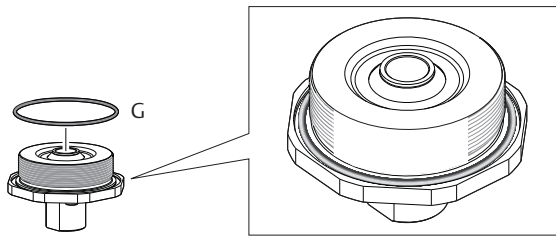

3. Mount the antenna adapter on flange/manhole cover.

Ensure the antenna adapter fits tightly to the flange/manhole cover.

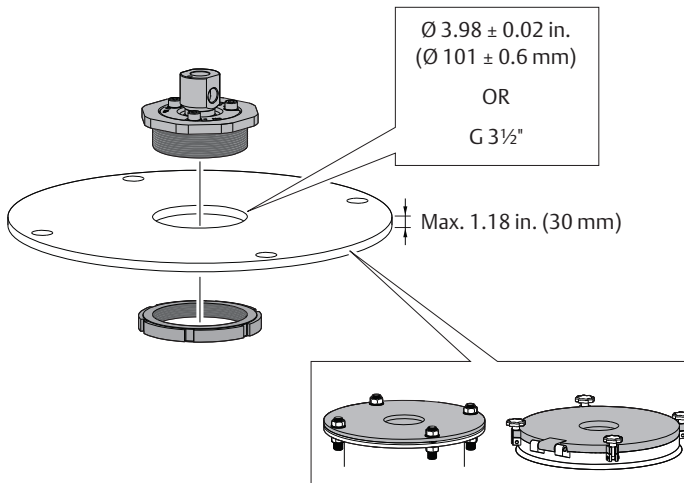

4. Remove the M20 adapter and visually inspect the O-rings for damage and dirt.

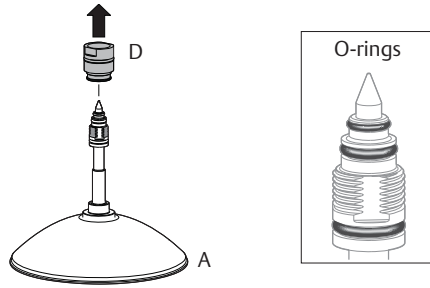

5. Carefully insert the antenna.

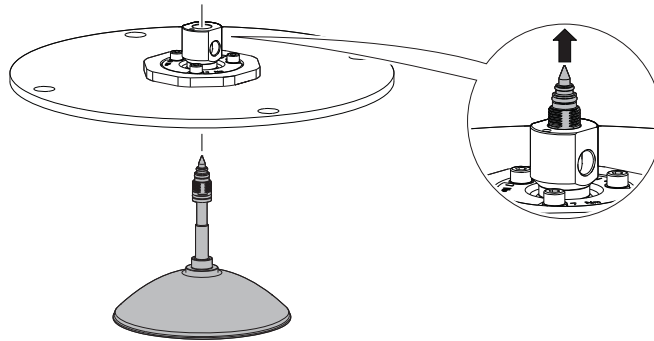

6. Secure the antenna.

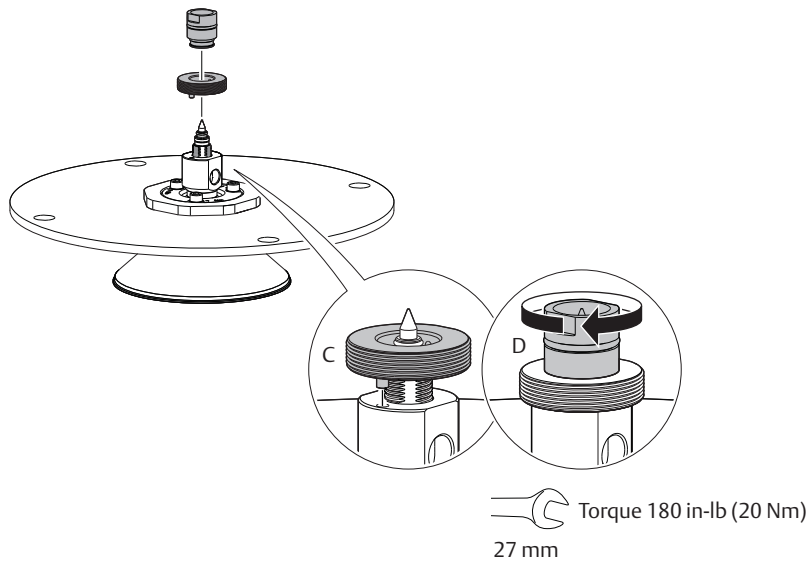

7. Tighten the set screw.

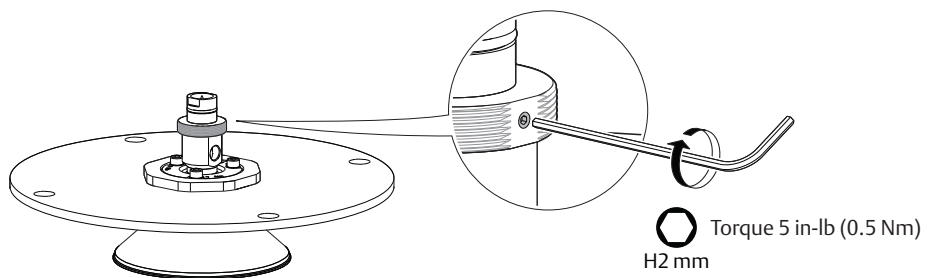

8. Lower the antenna assembly into the tank.

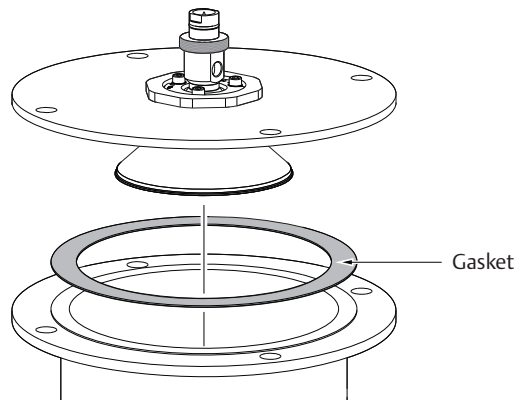

9. Tighten the bolts and nuts with sufficient torque for the flange and gasket choice.

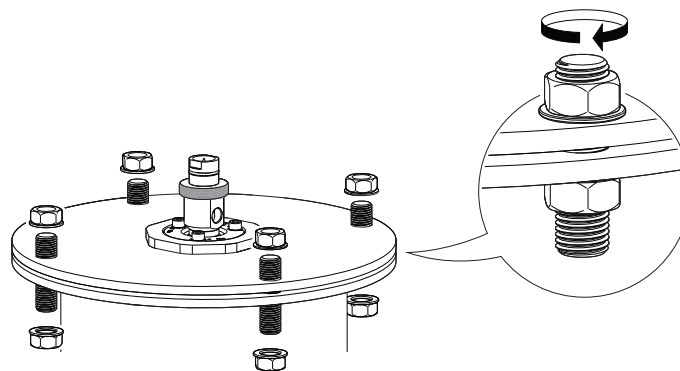

10. Adjust the inclination of the antenna (see [page 48](#)).
11. Connect the air purging system (see [page 51](#)).

### 3.5.3 Welded version

Figure 3-12. Components

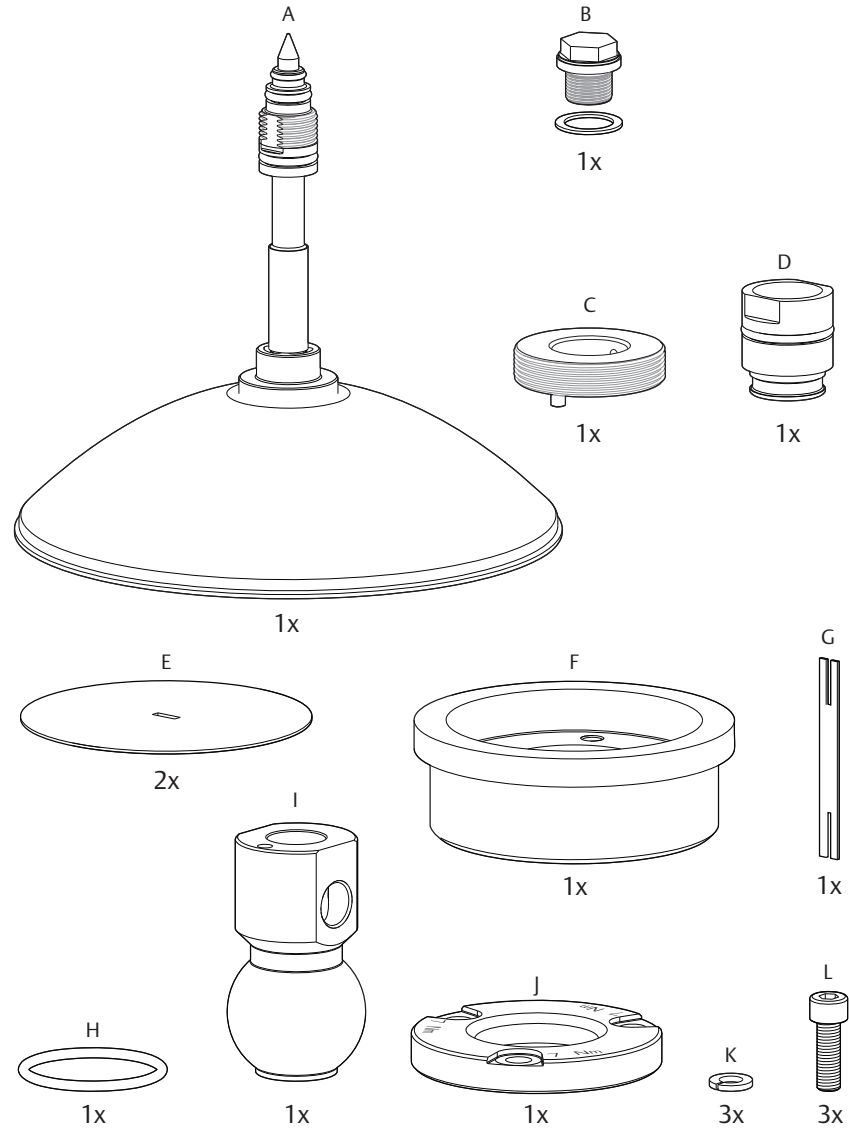

- A. Antenna
- B. Purge plug kit (optional with order)  
P/N 05400-1200-0001
- C. Threaded sleeve
- D. M20 adapter
- E. Weld protection plate
- F. Flange ball
- G. Weld protection bar
- H. O-ring
- I. Ball joint
- J. Clamp flange
- K. Washer
- L. M8 screw

**Procedure**

1. Mount the protection plates to flange/manhole cover.

These plates protect the internal surfaces of the flange ball from dust and sparks during welding.

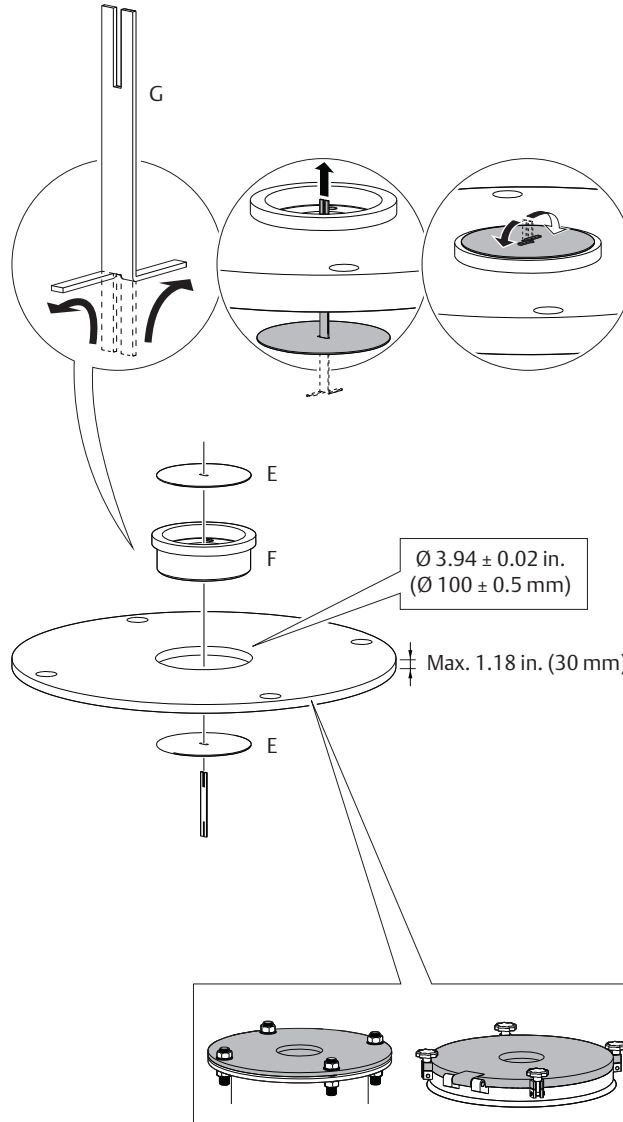

2. Weld the flange ball.

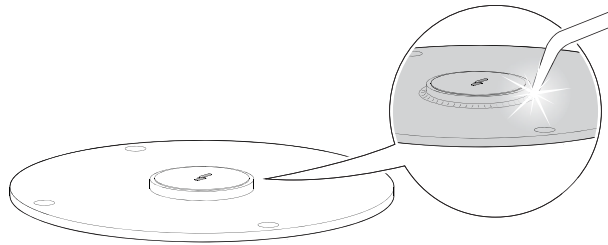

3. Remove the protection plates and visually inspect the internal surfaces of the flange ball for damage and dirt.

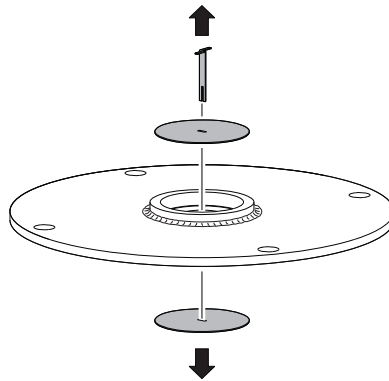

4. Mount the O-ring.

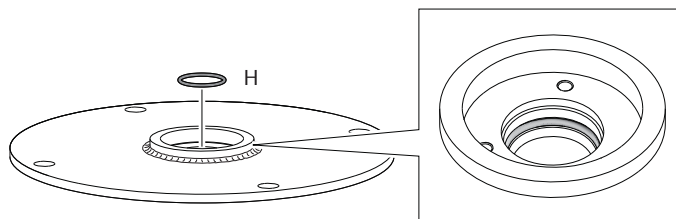



5. Mount the ball joint.
  - a. Insert the ball joint and place the clamp flange with the “7 Nm” marking side up.
  - b. Gradually tighten the M8 screws.

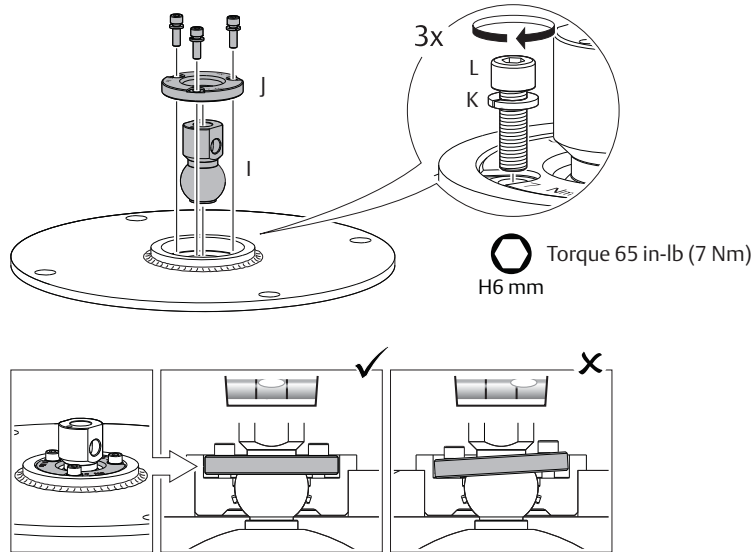

6. Remove the M20 adapter and visually inspect the O-rings for damage and dirt.

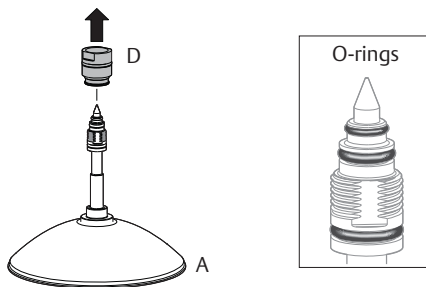

7. Carefully insert the antenna.

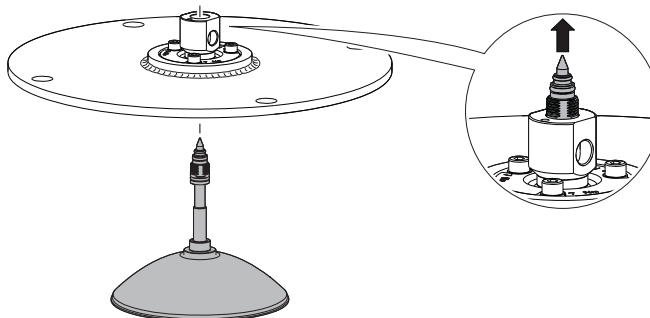

8. Secure the antenna.

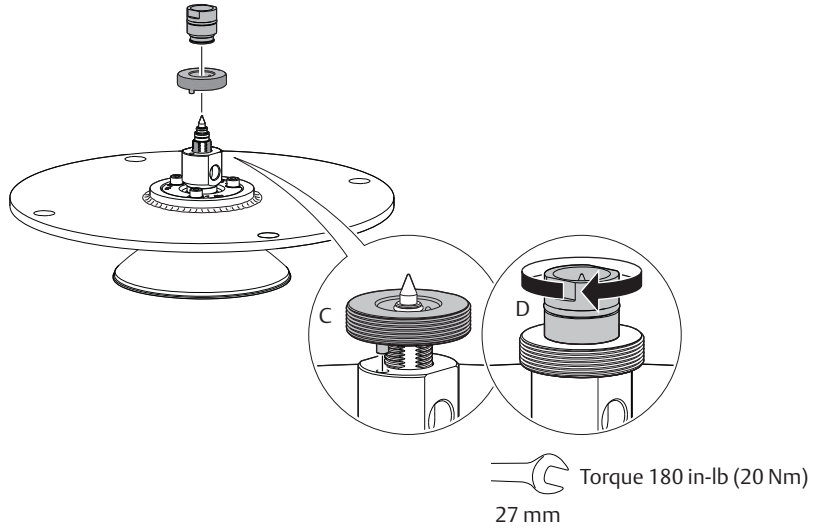

9. Tighten the set screw.

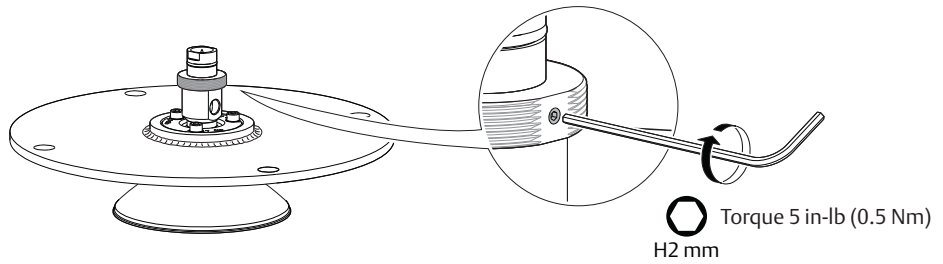

10. Lower the antenna assembly into the tank.

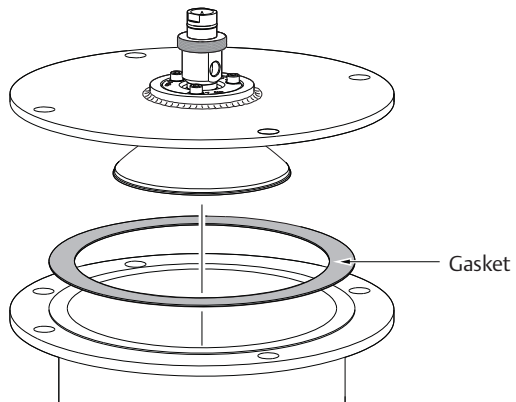

11. Tighten the bolts and nuts with sufficient torque for the flange and gasket choice.

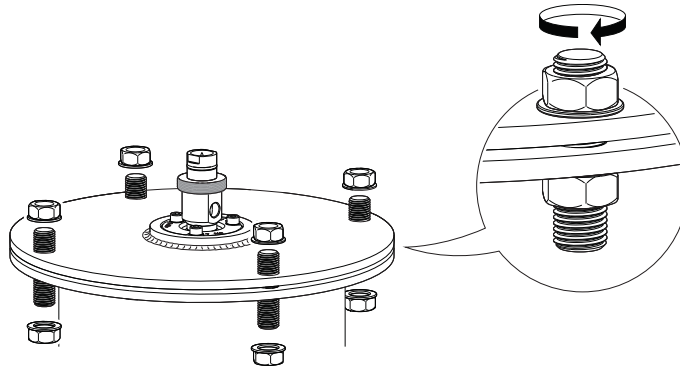

12. Adjust the inclination of the antenna (see [page 48](#)).
13. Connect the air purging system (see [page 51](#)).

### 3.5.4 Adjust the inclination of the antenna

#### ▲ WARNING

Contents may be under pressure.

- Do not loosen the M8 screws while in operation. Attempting to do so may release pressurized gases, resulting in serious injury or death.

1. Loosen the M8 screws until the transmitter can rotate smoothly.

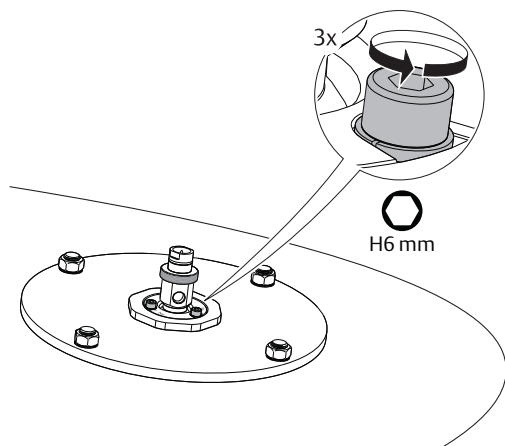

2. Rotate the antenna so the air purge connection is directed toward the tank wall.

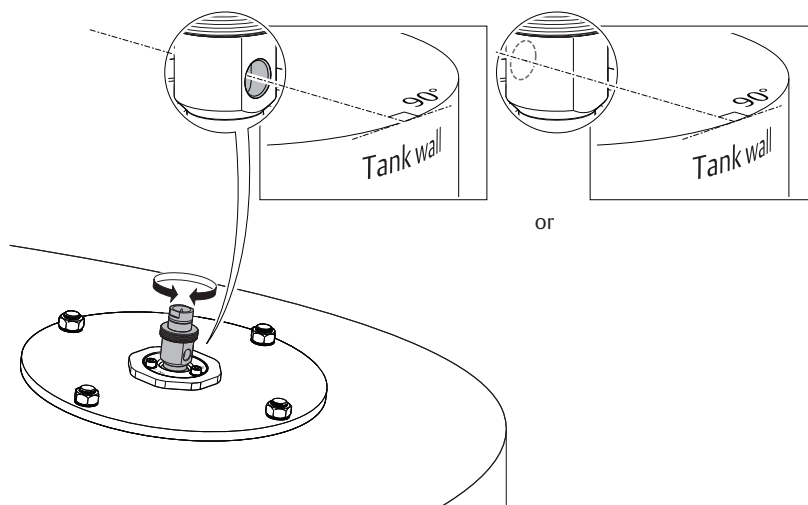

3. Place the circular level on top of the antenna assembly.

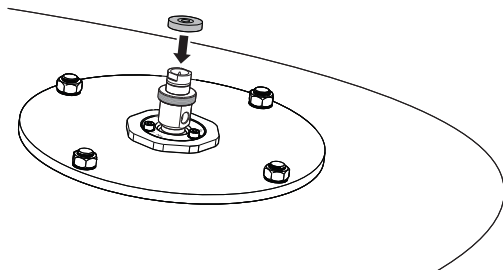

4. Adjust the inclination of the antenna.

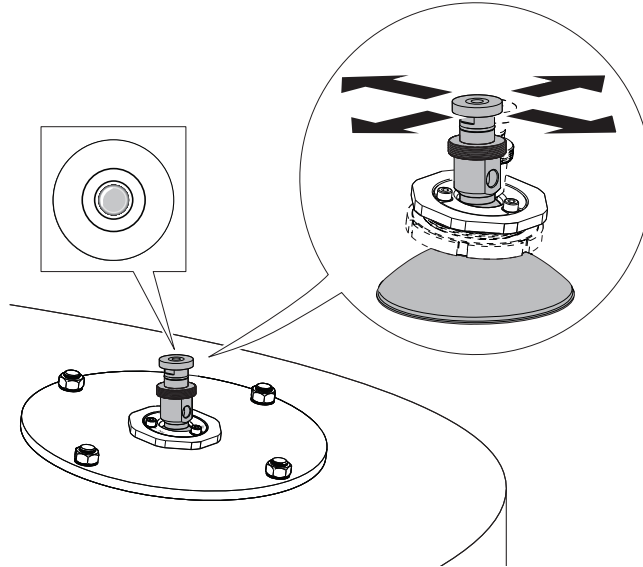

5. Gradually tighten the M8 screws.

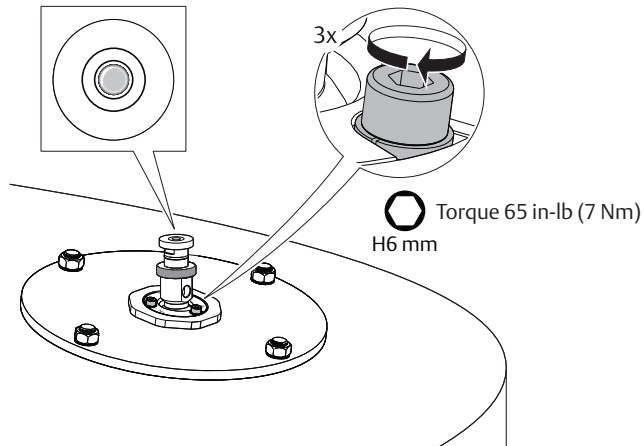

6. Remove the circular level.

