

Rosemount™ 3308 Series Wireless Guided Wave Radar, 3308A



PRELIMINARY

Contents

Section 1: Introduction

1.1 Using this manual	1
1.2 Product recycling/disposal.....	1

Section 2: Transmitter Overview

2.1 Theory of operation.....	3
2.2 Wireless by Emerson™.....	7
2.3 Application characteristics.....	7
2.3.1 Tank shape.....	7
2.3.2 In-tank obstructions.....	8
2.3.3 Interface level measurement.....	8
2.4 Application examples	9
2.5 Components of the transmitter	10
2.6 Probe selection guide	11

Section 3: Installation

3.1 Safety messages.....	13
3.2 Installation procedure.....	15
3.3 Review mounting considerations	16
3.3.1 Recommended mounting position.....	16
3.3.2 Flange connection on nozzles	18
3.3.3 Installation in non-metallic tanks and open-air applications	19
3.3.4 Installation in still pipe/chamber.....	20
3.4 Review mounting preparations.....	22
3.4.1 Measure tank height	22
3.4.2 Shorten the probe	23
3.4.3 Mount a centering disc for pipe installations	28
3.5 Anchor the probe.....	33
3.5.1 Flexible single/twin lead probe	33
3.5.2 Rigid single lead probe	34
3.5.3 Coaxial probe	35
3.6 Mount device on tank	36
3.6.1 Threaded tank connection	36
3.6.2 Tank connection with flange	38

3.6.3 Tank connection with loose flange (“plate design”)	40
3.6.4 Tank connection with Tri Clamp	41
3.6.5 Segmented probe	43
3.7 Ground the device	54
3.8 Install the power module	55
3.9 Position the antenna	55
3.10 Utilize the device display	56
3.10.1 Rotate the device display	56
3.10.2 Retrofitting	56

Section 4: Configuration

4.1 Overview	57
4.2 Safety messages.	58
4.3 Configuration procedure	59
4.4 System readiness	60
4.4.1 Confirm correct device driver.	60
4.5 Get started with your preferred configuration tool.	61
4.5.1 AMS Wireless Configurator (version 12.0 or later is required)	61
4.5.2 Field Communicator	63
4.6 Join device to wireless network.	64
4.6.1 Power up the wireless device	64
4.6.2 Connect to device.	66
4.6.3 Configure update rate	67
4.6.4 Obtain network ID and join key	67
4.6.5 Enter network ID and join key	68
4.6.6 Verify device joins network.	68
4.7 Configure device using guided setup.	72
4.7.1 Connect to device.	72
4.7.2 Basic setup.	73
4.7.3 Optional setup	73
4.8 Verify level.	74

Section 5: Operation

5.1 Safety messages.	75
5.2 Device display screen messages	77
5.2.1 Variable screens	77
5.2.2 Diagnostic button screen sequence	78
5.3 View measurement values	80

5.3.1 View current measurement values	80
5.3.2 View trends	80
5.3.3 Interpret measurement status bars	80
5.4 Check device status	81

Section 6: Service and Troubleshooting

6.1 Safety messages	83
6.2 Alert messages	84
6.2.1 Device display alerts	84
6.2.2 Alert messages in AMS Wireless Configurator and Field Communicator	86
6.3 Troubleshooting guide	90
6.3.1 Incorrect level readings	90
6.3.2 Incorrect or missing interface level reading	91
6.3.3 Power module troubleshooting	92
6.3.4 Device display troubleshooting	92
6.3.5 Wireless network troubleshooting	92
6.4 Service and troubleshooting tools	93
6.4.1 Reading the echo curve	93
6.4.2 Adjusting thresholds	94
6.4.3 Viewing measurement history	98
6.4.4 Reviewing network join status and details	99
6.4.5 Locating the device	99
6.4.6 Using the simulation mode	100
6.4.7 Using the verification method	100
6.5 Application challenges	100
6.5.1 Resolving thin oil layers	100
6.5.2 Handling disturbances at the top of the tank	102
6.5.3 Interface measurements with fully submerged probes	105
6.5.4 Noise or weak surface echoes	106
6.6 Power module replacement	106
6.7 Transmitter head replacement	108
6.8 Probe replacement	109
6.9 Service support	110

Appendix A: Specifications and Reference Data

A.1 Performance specifications	111
A.1.1 General	111
A.1.2 Environment	111

A.1.3 Interface measuring range	112
A.1.4 Accuracy over measuring range	114
A.2 Functional specifications	116
A.2.1 General	116
A.2.2 Wireless	116
A.2.3 Display and configuration	117
A.2.4 Temperature limits	117
A.2.5 Process temperature and pressure rating	118
A.2.6 Flange rating	118
A.2.7 Plate design	118
A.2.8 Interface measurements	119
A.2.9 Conditions used for flange strength calculations	120
A.3 Physical specifications	121
A.3.1 Material selection	121
A.3.2 Tank connection	121
A.3.3 Housing and enclosure	121
A.3.4 Flange dimensions	121
A.3.5 Probes	121
A.3.6 Material exposed to tank atmosphere	122
A.3.7 Weight	122
A.3.8 End weight and anchoring options	123
A.3.9 Engineered solutions	123
A.4 Ordering information	124
A.5 Spare parts and accessories	130
A.6 Dimensional drawings	139

Appendix B: Product Certifications

B.1 Safety messages	147
B.2 European Union directive information	148
B.3 Telecommunication compliance	148
B.4 FCC and IC	148
B.5 Ordinary location certification for FM approvals	148
B.6 Hazardous locations certificates	148
B.6.1 U.S.A.	148
B.6.2 Canada	149
B.6.3 Europe	149
B.6.4 International	149
B.6.5 Brazil	150

B.6.6 China	150
B.6.7 Japan	150
B.6.8 EAC – Belarus, Kazakhstan, Russia	150
B.6.9 Taiwan	150
B.7 Other certifications	150
B.8 Approval drawings	150

Appendix C: High Gain Remote Antenna Option

C.1 Safety messages	153
C.2 Functional and physical specifications	154
C.2.1 General	154
C.2.2 Wireless	154
C.2.3 Coaxial cable	154
C.2.4 RF Lightning Arrestor	154
C.2.5 Mounting bracket	154
C.2.6 Antenna	154
C.3 Review installation considerations	154
C.3.1 Antenna mounting	154
C.3.2 Antenna height	154
C.3.3 Affix coaxial cable	155
C.3.4 Install coaxial drip loop	155
C.3.5 Apply coaxial sealant moisture protection	155
C.4 Transient/lightning considerations	155
C.4.1 Gateway transient protection	155
C.4.2 RF lightning arrestor ground connection	155
C.5 Install the high gain remote antenna	156

Appendix D: Configuration Parameters

D.1 Safety messages	159
D.2 Menu overview of the Device Descriptor (DD)	160
D.3 Configuration parameters	161
D.3.1 Guided setup	161
D.3.2 Manual setup - Device	164
D.3.3 Manual setup - Level	168
D.3.4 Alert setup	172
D.3.5 Echo Tuning	176

Appendix E: Alert Message Mapping

Rosemount™ 3308 Series Wireless Guided Wave Radar Level Transmitter

NOTICE

Read this manual before working with the product. For personal and system safety, and for optimum product performance, make sure you thoroughly understand the contents before installing, using, or maintaining this product.

For technical assistance, contacts are listed below:

Customer Central

Technical support, quoting, and order-related questions.

United States - 1-800-999-9307 (7:00 am to 7:00 pm CST)

Asia Pacific- 65 777 8211

Europe / Middle East / Africa - 49 (8153) 9390

North American Response Center

Equipment service needs.

1-800-654-7768 (24 hours a day — includes Canada)

Outside of these areas, contact your local Emerson™ representative.

Power Module Considerations.

Each Power Module contains two "C" size primary lithium/thionyl chloride batteries. Each battery contains approximately 2.5 grams of lithium, for a total of 5 grams in each pack. Under normal conditions, the battery materials are self-contained and are not reactive as long as the batteries and the pack integrity are maintained. Care should be taken to prevent thermal, electrical or mechanical damage. Contacts should be protected to prevent premature discharge.

Battery hazards remain when cells are discharged.

Power modules should be stored in a clean and dry area. For maximum battery life, storage temperature should not exceed 30 °C.

The Power Module may be replaced in a hazardous area. The Power Module has surface resistivity greater than one gigaohm and must be properly installed in the wireless device enclosure. Care must be taken during transportation to and from the point of installation to prevent electrostatic charge build-up.

Shipping considerations for wireless products.

The unit was shipped to you without the Power Module installed. Please remove the Power Module prior to shipping the unit.

Each Power Module contains two "C" size primary lithium/thionyl chloride batteries. Primary lithium batteries (charged or discharged) are regulated during transportation by the U.S. Department of Transportation. They are also covered by IATA (International Air Transport Association), ICAO (International Civil Aviation Organization), and ARD (European Ground Transportation of Dangerous Goods). It is the responsibility of the shipper to ensure compliance with these or any other local requirements. Consult current regulations and requirements before shipping.

⚠ WARNING**Explosions could result in death or serious injury.**

- Verify that the operating environment of the gauge is consistent with the appropriate hazardous locations certifications.
- Installation of device in an explosive environment must be in accordance with appropriate local, national and international standards, codes, and practices.
- Ensure device is installed in accordance with intrinsically safe or non-incendive field practices.

Electrical shock can result in death or serious injury.

- Ground device on non-metallic tanks (e.g. fiberglass tanks) to prevent electrostatic charge build-up.
- Single lead probes are sensitive for strong electromagnetic fields and therefore not suitable for non-metallic tanks.
- Care must be taken during transportation of power module to prevent electrostatic charge build-up.
- Device must be installed to ensure a minimum antenna separation distance of 8 in. (20 cm) from all persons.
- Probes covered with plastic and/or with plastic discs may generate an ignition-capable level of electrostatic charge under certain extreme conditions. Therefore, when the probe is used in a potentially explosive atmosphere, appropriate measures must be taken to prevent electrostatic discharge.

Process leaks could result in death or serious injury.

- Only qualified personnel should install the equipment.
- Install transmitter prior to process start-up.
- Install and tighten process connectors before applying pressure.
- Handle the transmitter carefully.
- Do not remove the transmitter while in operation.
- If the process seal is damaged, gas could escape from the tank when removing the transmitter head from the probe.

Failure to follow safe installation guidelines could result in death or serious injury.

- Verify that the operating environment of the gauge is consistent with the appropriate hazardous locations certifications.
- Make sure the transmitter is installed by qualified personnel and in accordance with applicable code of practice.
- Use the equipment only as specified in this manual. Failure to do so may impair the protection provided by the equipment.

⚠ WARNING

Electronic boards are electrostatically sensitive. Failure to observe proper handling precautions for static-sensitive components can result in damage to the electronic components. Do not remove the electronic boards from the Rosemount 3308 Series Transmitter.

To ensure long life for your radar transmitter, and to comply with hazardous location installation requirements, tighten covers on both sides of the electronics housing.

Any substitution of non-recognized parts may jeopardize safety. Repair, e.g. substitution of components etc., may also jeopardize safety and is under no circumstances allowed.

⚠ CAUTION

This device complies with Part 15 of the FCC Rules. Operation is subject to the following conditions: This device may not cause harmful interference. This device must accept any interference received, including interference that may cause undesired operation. This device must be installed to ensure a minimum antenna separation distance of 20 cm (8 in.) from all persons.

The products described in this document are NOT designed for nuclear-qualified applications.

Using non-nuclear qualified products in applications that require nuclear-qualified hardware or products may cause inaccurate readings.

For information on Rosemount nuclear-qualified products, contact your local Emerson Sales Representative.

Individuals who handle products exposed to a hazardous substance can avoid injury if they are informed of and understand the hazard. If the product being returned was exposed to a hazardous substance as defined by Occupational Safety and Health Administration (OSHA), a copy of the required Material Safety Data Sheet (MSDS) for each hazardous substance identified must be included with the returned goods.

Use caution when handling the Power Module. The Power Module may be damaged if dropped from heights in excess of 20 ft. (6 m).

Changes or modifications to the equipment not expressly approved by Rosemount Inc. could void the user's authority to operate the equipment.

Section 1 Introduction

1.1 Using this manual

The sections in this manual provide information on installing, configuring, operating, and maintaining the Rosemount™ 3308 Series Transmitter. The sections are organized as follows:

[Section 2: Transmitter Overview](#) provides an introduction to theory of operation and description of the transmitter. Information on applications and a probe selection guide are also included.

[Section 3: Installation](#) contains mechanical and electrical installation instructions.

[Section 4: Configuration](#) provides instructions on how to configure and make the transmitter join the wireless network.

[Section 5: Operation](#) contains operation techniques such as viewing measurement data and display functionality.

[Section 6: Service and Troubleshooting](#) provides troubleshooting techniques for the most common operating problems, as well as diagnostic and error messages, and service instructions.

[Appendix A: Specifications and Reference Data](#) supplies reference and specification data, as well as ordering information.

[Appendix B: Product Certifications](#) contains hazardous locations certifications and approval drawings.

[Appendix C: High Gain Remote Antenna Option](#) contains specification and installation information of the high gain remote antenna option.

[Appendix D: Configuration Parameters](#) provides a menu overview for the Device Descriptor in AMS Wireless Configurator and the Field Communicator. Description of the configuration parameters is also included.

[Appendix E: Alert Message Mapping](#) outlines the most important alerts in the HART® command 48 Additional Status Field for Rosemount 3308 Series.

1.2 Product recycling/disposal

Recycling of equipment and packaging should be taken into consideration and disposed in accordance with local and national legislation/regulations.

Section 2 Transmitter Overview

Theory of operation	page 3
Wireless by Emerson™	page 7
Application characteristics	page 7
Application examples	page 9
Components of the transmitter	page 10
Probe selection guide	page 11

2.1 Theory of operation

The Rosemount™ 3308 Series is the first true wireless level transmitter that is based on the Time Domain Reflectometry (TDR) principle. Low power nano-second-pulses are guided along a probe submerged in the process media. When a pulse reaches the surface of the material it is measuring, part of the energy is reflected back to the transmitter, and the time difference between the generated and reflected pulse is converted into a distance from which the total level or interface level is calculated (see Figure 2-1). See Figure 2-2 for a schematic overview of the signal processing.

The reflectivity of the product is a key parameter for measurement performance. A high dielectric constant of the media gives better reflection and a longer measuring range.

Figure 2-1. Guided Wave Radar Operating Principle

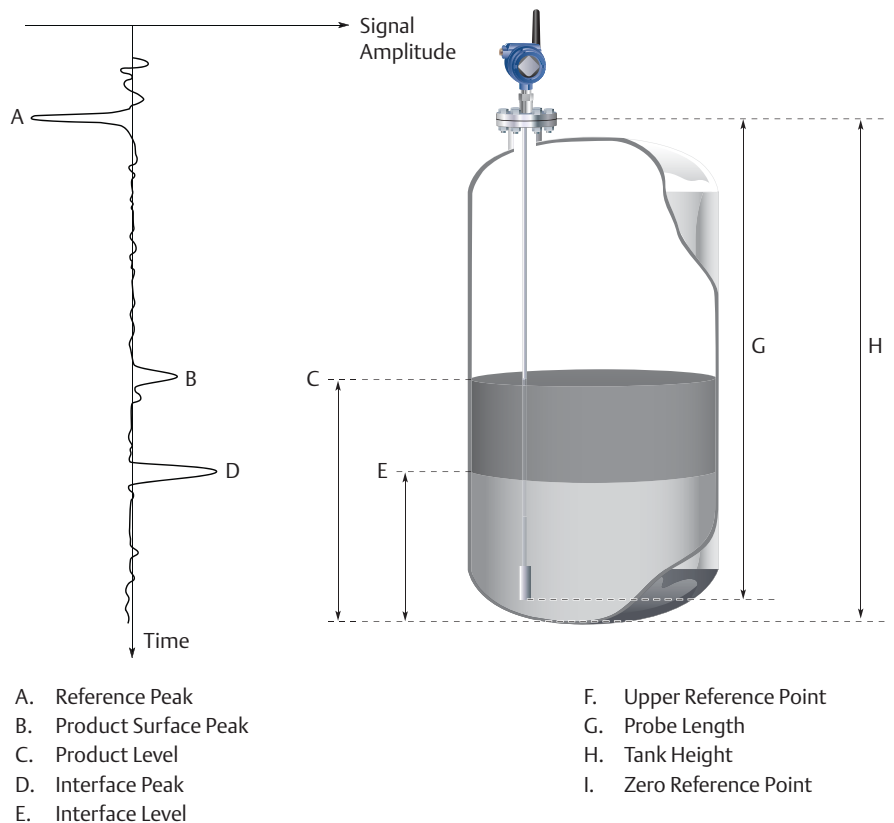
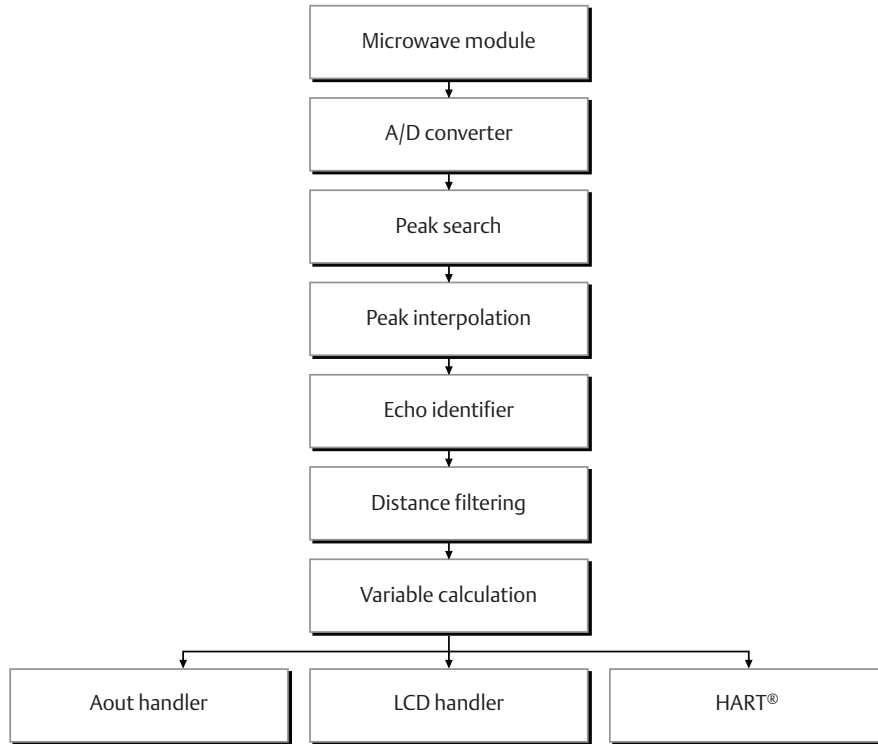

Figure 2-2. Flowchart of the Signal Processing

Reference peak

This peak is caused by the transition between transmitter and the tank vapor space or air. It is used by the transmitter as a starting reference point for distance to the level surface.

Product surface peak

This peak indicates the product level and is caused by a reflection from the product surface.

Interface peak

This peak indicates the interface level. The peak is caused by reflection from the interface between an upper product and a bottom product with a relatively high dielectric constant. This peak is identified when the Measurement Mode is set to Product Level and Interface Level or Interface Level with Submerged Probe.

Probe end peak

It is caused by reflection from the probe end. If the probe is grounded, the peak will be positive. If the probe end is submerged in a high dielectric media, such as water, it will not be visible.

Upper reference point

The Upper Reference Point is located at the underside of the threaded adapter, transmitter flange, or Tri Clamp, as illustrated in [Figure 2-3 on page 5](#).

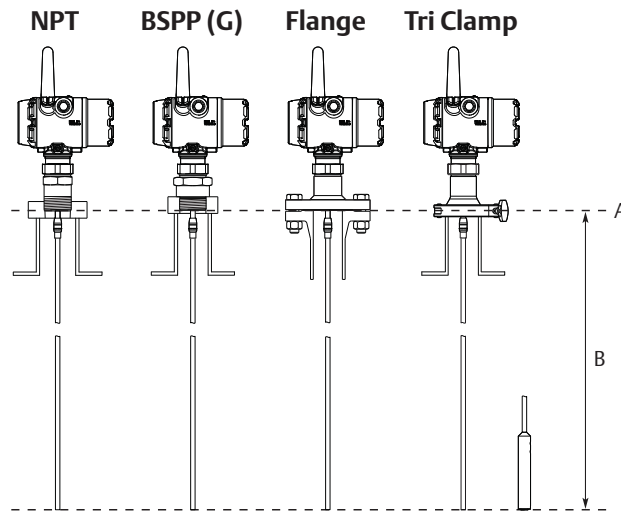
Figure 2-3. Upper Reference Point

- A. Upper Reference Point
- B. Probe Length

Zero reference point

The Zero Reference Point is selected by the user and is usually located close to or at the bottom of the tank. The Zero Reference Point can be set to any position in the tank by adjusting the Tank Height.

Tank height

The Tank Height is the distance from the Upper Reference Point to the Zero Reference Point. The transmitter measures the distance to the product surface and subtracts this value from the Tank Height to determine the level.

Probe length

The probe length is the distance between the Upper Reference Point and the end of the probe. If a weight is used at the end of the probe it shall be included.

Blind zones

The measuring range depends on probe type, dielectric constant of the product and installation environment, and is limited by the Blind Zones at the very top and bottom of the probe. In the Blind Zones, the accuracy exceeds ± 1.18 in. (30 mm), and measurements may not be possible. Measurements close to the Blind Zones will have reduced accuracy.

Figure 2-4 illustrates how the measuring range is related to the Blind Zones and the areas with reduced accuracy. Values for different probe types and dielectric constants are presented in section “Accuracy over measuring range” on page 114.

Figure 2-4. Blind Zones

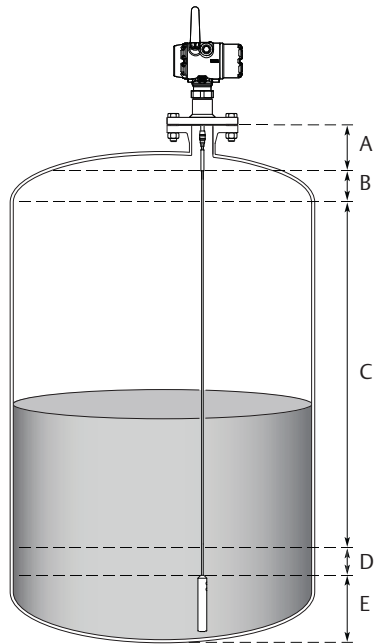

- A. Upper Blind Zone
- B. Reduced Accuracy
- C. Recommended Measuring Range
- D. Reduced Accuracy
- E. Lower Blind Zone

Note

Measurements may not be possible in the Blind Zones, and measurements close to the Blind Zones will have reduced accuracy. Therefore, the alarm points should be configured outside these zones.

2.2 Wireless by Emerson™

The Emerson Wireless network is a self-organizing solution. Wireless field instruments send data to a Gateway, directly or routed through any of the wireless devices in the network, as illustrated in Figure 2-5. Multiple communication paths are managed and analyzed in parallel to assure optimal communication and sustained network reliability even if obstructions are introduced.

Figure 2-5. Emerson Wireless Network

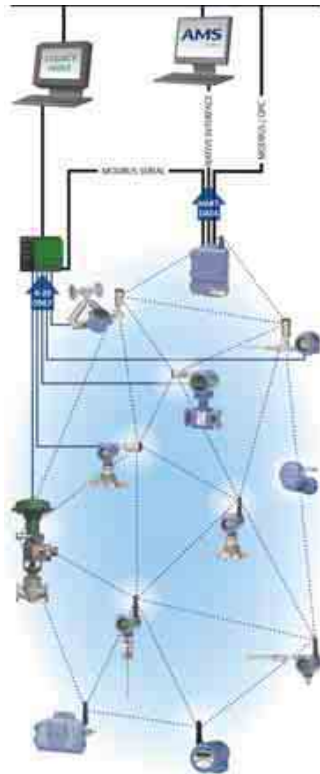

Gateways interface with existing host systems using industry standard protocols, and native integration into DeltaV™ and Ovation™ is transparent and seamless.

Interference from other radios, WiFi, and EMC sources is avoided through Time Synchronized Channel Hopping and Direct Sequence Spread Spectrum (DSSS). Also, a layered security implementing industry standard Encryption, Authentication, Verification, Anti-Jamming, and Key Management ensures that data transmissions are secure and received only by the Gateway.

2.3 Application characteristics

2.3.1 Tank shape

The guided wave radar transmitter is insensitive to the tank shape. Since the radar signal travels along a probe, the shape of the tank bottom has no effect on the measurement performance. The transmitter handles flat or dish-bottom tanks equally well.

2.3.2 In-tank obstructions

The Rosemount 3308 Series Transmitter is relatively insensitive to objects in the tank since the radar signal is transmitted along a probe.

Avoid physical contact between probes and agitators as well as applications with strong fluid movement unless the probe is anchored. If the probe can move within 1 ft. (30 cm) away from any object, such as an agitator, during operation then probe tie-down is recommended.

In order to stabilize the probe for side forces, you have the option to either hang a weight at the probe end (flexible probes only) or fix/guide the probe to the tank bottom.

2.3.3 Interface level measurement

Rosemount 3308 Series Transmitter is well suited for measuring the interface of oil and water, or other liquids with significant dielectric differences.

Figure 2-6. Interface Level Measurement

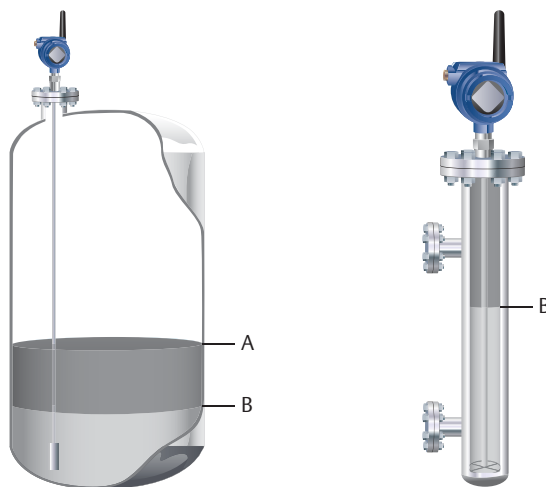

- A. Product Level
- B. Interface Level

All probes can be used for measuring interfaces. Single probes are the preferred choice in almost all applications but depending on the application and installation geometries a coaxial probe or a flexible twin probe may be a better fit.

For measuring the interface level, the transmitter uses the residual wave of the first reflection. Part of the wave, which was not reflected at the upper product surface, continues until it is reflected at the lower product surface. The speed of this wave depends fully on the dielectric constant of the upper product.

The maximum allowable upper product thickness/measuring range is primarily determined by the dielectric constants of the two liquids. Target applications include interfaces between oil/oil-like and water/water-like liquids. For such applications the upper product dielectric constant is low (<3) and the lower product dielectric constant is high (>20). Refer to [“Interface measurements” on page 119](#) for further interface application guidelines.



Emulsion layers

Sometimes there is an emulsion layer (mix of the products) between the two products which, depending on its characteristics, will affect interface measurements. Please consult factory for guidelines on how to handle emulsion layers.

2.4 Application examples

The Rosemount 3308 Series Transmitter is suited for aggregate (total) level measurements on a wide range of liquids, semi-liquids, and liquid to liquid interfaces.

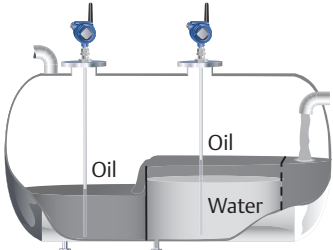
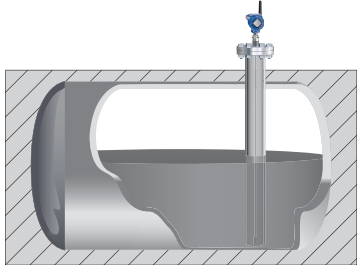
Moreover, the reliable and accurate guided wave radar technology offers a versatile solution that is virtually unaffected by process conditions such as temperature, pressure, vapor gas mixtures, density, turbulence, bubbling/boiling, varying dielectric media, pH, and viscosity.

<p>Production, storage, and buffer tanks</p>	<p>The Rosemount 3308 Series Transmitter is ideal for production and shorter storage or buffer tanks that contain oil, gas condensate, water, or chemicals.</p>	
<p>Low pressure separators</p>	<p>The Rosemount 3308 Series Transmitter can measure both level and interface level in for example separator applications.</p>	
<p>Waste tanks and sump pits</p>	<p>The Rosemount 3308 Series Transmitter is a good choice for waste tanks and underground tanks, such as sump pits.</p>	
<p>Chamber applications</p>	<p>The Rosemount 3308 Series Transmitter is a good choice for both chamber and pipe installations.</p>	

2.5 Components of the transmitter

The Rosemount 3308 Series transmitter housing contains advanced electronics for signal processing. The transmitter housing is made of aluminum or stainless steel, depending on specified option code.

The radar electronics produces an electromagnetic pulse which is guided by the probe.

There are different probe types available for various applications: Flexible Single Lead, Rigid Single Lead, Flexible Twin Lead, and Coaxial.

Figure 2-7. Transmitter Components

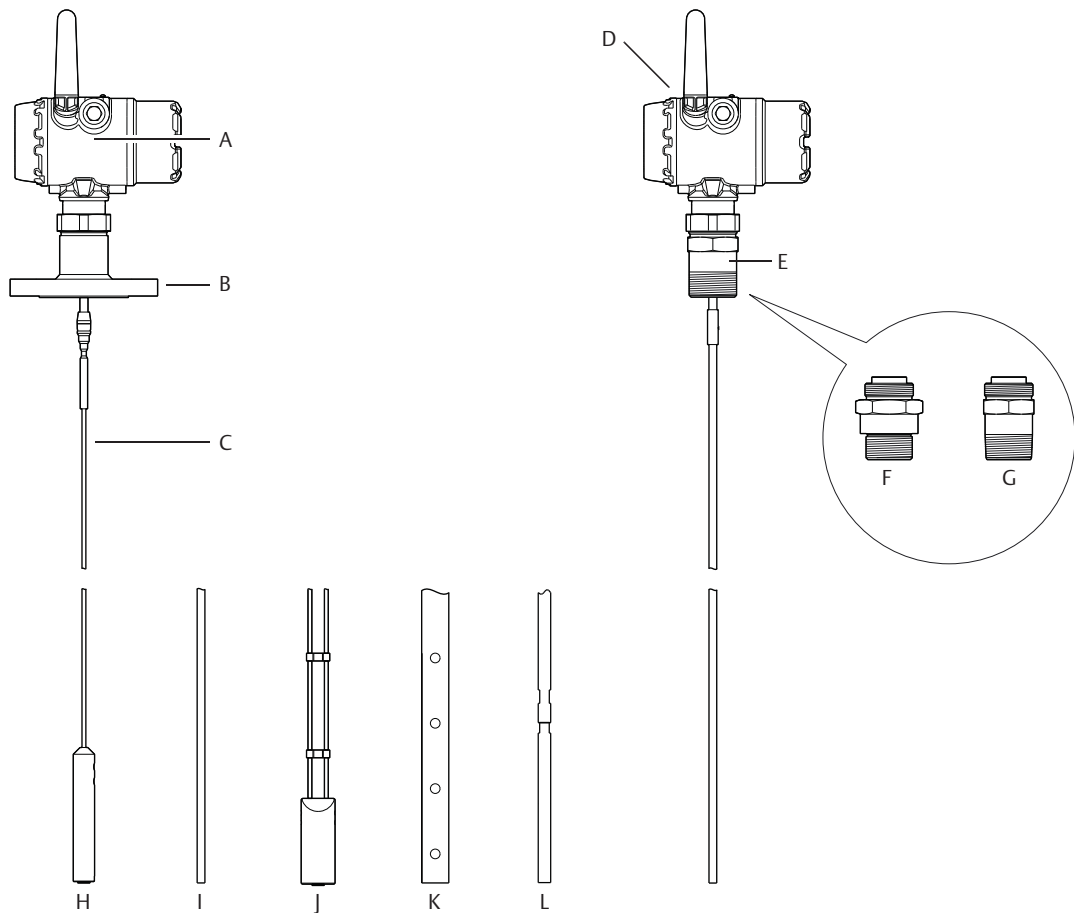

- | | |
|---------------------------------|--------------------------------------|
| A. Radar Electronics | G. NPT |
| B. Flanged Process Connections | H. Flexible Single Lead with weight |
| C. Probe | I. Rigid Single Lead |
| D. Dual Compartment Housing | J. Flexible Twin Lead with weight |
| E. Threaded Process Connections | K. Coaxial |
| F. BSPP (G) | L. Segmented rigid single lead probe |

2.6 Probe selection guide

Use the following guidelines to choose appropriate probe for your Rosemount 3308 Series transmitter:

Table 2-1. Probe Selection Guide. G=Good, NR=Not Recommended, AD=Application Dependent (consult factory)

	Flexible single lead	Rigid single lead, segmented rigid single lead	Flexible twin lead	Coaxial
Measurements				
Level	G	G	G	G
Interface (liquid/liquid)	G	G	G	G ⁽¹⁾
Process medium characteristics				
Changing density	G	G	G	G
Changing dielectric ⁽²⁾	G	G	G	G
Wide pH variations	G	G	G	G
Pressure changes	G	G	G	G
Temperature changes	G	G	G	G
Condensing vapors	G	G	G	G
Bubbling/boiling surfaces	G	G	G	G
Foam (mechanical avoidance)	NR	NR	NR	AD
Foam (top of foam measurement)	AD	AD	AD	NR
Foam (foam and liquid measurement)	AD	AD	AD	NR
Clean liquids	G	G	G	G
Liquid with dielectric<2.0 ⁽³⁾	AD	AD	AD	AD
Coating liquids ⁽⁴⁾	G	G	NR	NR
Viscous liquids ⁽⁴⁾	G	G	AD	NR
Crystallizing liquids	AD	AD	NR	NR
Solids/Powders	NR	NR	NR	NR
Fibrous liquids	G	G	NR	NR
Tank environment considerations				
Probe is close (<12 in./30 cm) to disturbing objects	NR	NR	AD	G
Tall and narrow mounting nozzles (diameter <6 in./15 cm and height>diameter + 4 in./10 cm)	AD	AD	AD	G
Probe might touch nozzle / disturbing object	NR	NR	NR	G
Liquid or vapor spray might touch probe	NR	NR	NR	G
High turbulence	AD ⁽⁵⁾	G	AD ⁽⁵⁾	G
Turbulent conditions causing breaking forces	AD	NR	AD	NR
Non-metallic tanks or open atmosphere applications	AD ⁽⁶⁾	AD ⁽⁶⁾	AD ⁽⁶⁾	G

1. Not in fully submerged applications.
2. For overall level applications a changing dielectric has no effect on the measurement. For interface measurements a changing dielectric of the top fluid will degrade the accuracy of the interface measurement.
3. See Table A-1 on page 113 for more information.
4. See Table A-2 on page 113 for more information.
5. Ok If probe is anchored.
6. Not suitable in applications with disturbing EMC from nearby equipment.

Section 3 Installation

Safety messages	page 13
Installation procedure	page 15
Review mounting considerations	page 16
Review mounting preparations	page 22
Anchor the probe	page 33
Mount device on tank	page 36
Ground the device	page 54
Install the power module	page 55
Position the antenna	page 55
Utilize the device display	page 56

3.1 Safety messages

Procedures and instructions in this section may require special precautions to ensure the safety of the personnel performing the operations. Information that raises potential safety issues is indicated by a warning symbol (⚠). Refer to the following safety messages before performing an operation preceded by this symbol.

⚠ WARNING

Failure to follow safe installation guidelines could result in death or serious injury.

- Verify that the operating environment of the gauge is consistent with the appropriate hazardous locations certifications.
- Make sure the transmitter is installed by qualified personnel and in accordance with applicable code of practice.
- Use the equipment only as specified in this manual. Failure to do so may impair the protection provided by the equipment.

Explosions could result in death or serious injury.

- Verify that the operating environment of the gauge is consistent with the appropriate hazardous locations certifications.
- Installation of device in an explosive environment must be in accordance with appropriate local, national and international standards, codes, and practices.
- Ensure device is installed in accordance with intrinsically safe or non-incendive field practices.

⚠ WARNING**Electrical shock can result in death or serious injury.**

- Ground device on non-metallic tanks (e.g. fiberglass tanks) to prevent electrostatic charge build-up.
- Single lead probes are sensitive for strong electromagnetic fields and therefore not suitable for non-metallic tanks.
- Care must be taken during transportation of power module to prevent electrostatic charge build-up.
- Device must be installed to ensure a minimum antenna separation distance of 8 in. (20 cm) from all persons.
- Probes covered with plastic and/or with plastic discs may generate an ignition-capable level of electrostatic charge under certain extreme conditions. Therefore, when the probe is used in a potentially explosive atmosphere, appropriate measures must be taken to prevent electrostatic discharge.

Process leaks could result in death or serious injury.

- Only qualified personnel should install the equipment.
- Install transmitter prior to process start-up.
- Install and tighten process connectors before applying pressure.
- Handle the transmitter carefully.
- Do not remove the transmitter while in operation.
- If the process seal is damaged, gas could escape from the tank when removing the transmitter head from the probe.

⚠ WARNING

Electronic boards are electrostatically sensitive. Failure to observe proper handling precautions for static-sensitive components can result in damage to the electronic components. Do not remove the electronic boards from the Rosemount™ 3308 Series Transmitter.

To ensure long life for your radar transmitter, and to comply with hazardous location installation requirements, tighten covers on both sides of the electronics housing.

Any substitution of non-recognized parts may jeopardize safety. Repair, e.g. substitution of components etc., may also jeopardize safety and is under no circumstances allowed.

⚠ CAUTION

Use caution when handling the Power Module. The Power Module may be damaged if dropped from heights in excess of 20 ft. (6 m).

This device complies with Part 15 of the FCC Rules. Operation is subject to the following conditions: This device may not cause harmful interference. This device must accept any interference received, including interference that may cause undesired operation. This device must be installed to ensure a minimum antenna separation distance of 20 cm (8 in.) from all persons.

3.2 Installation procedure

Follow these steps for proper installation:

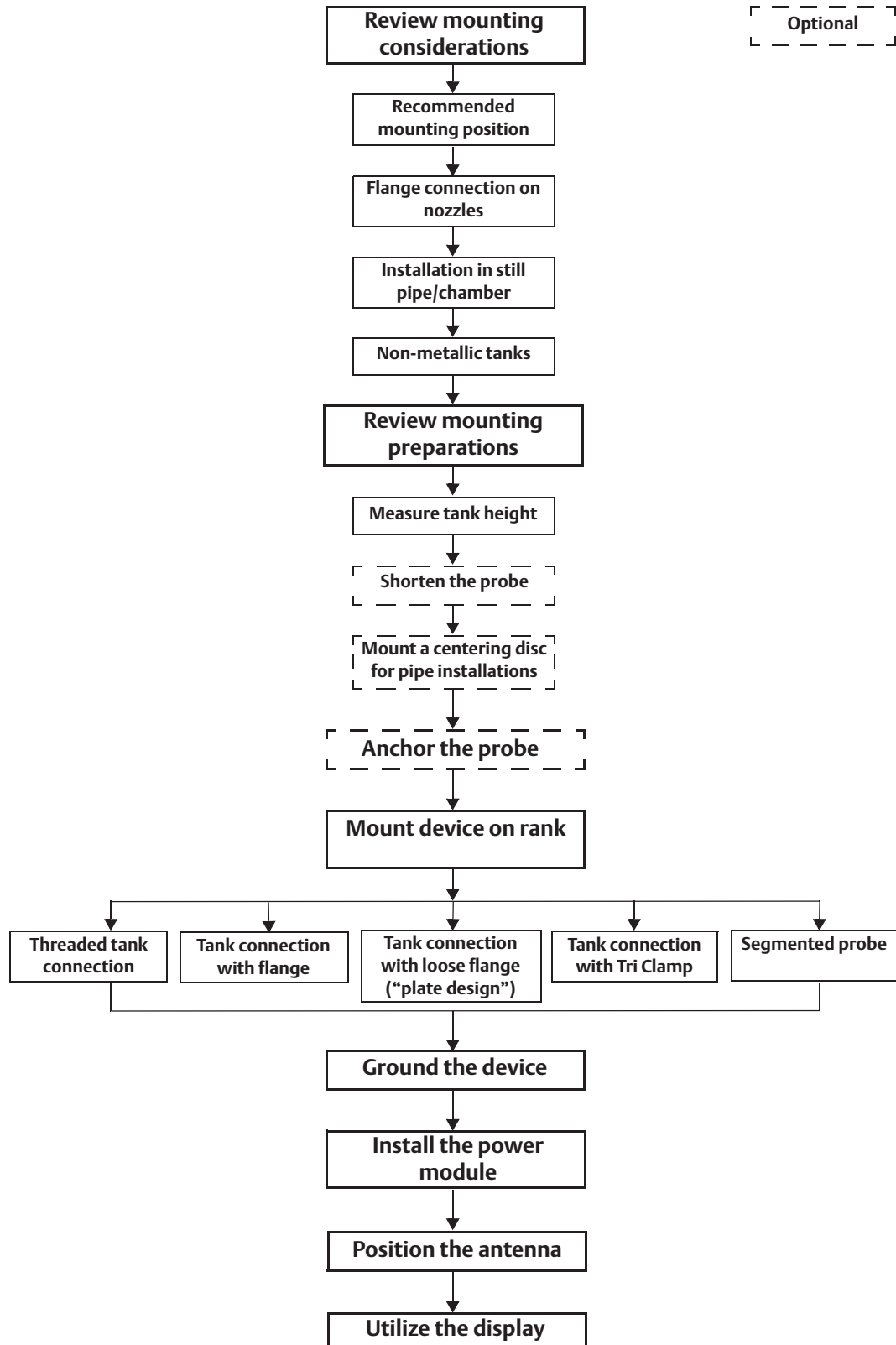

3.3 Review mounting considerations

Before installing the Rosemount 3308 Series Transmitter, consider recommendations for sufficient free space, mounting position and special needs for non-metallic tanks.

3.3.1 Recommended mounting position

When finding an appropriate mounting position for the transmitter, the conditions of the tank must be carefully considered. The transmitter should be mounted so that the influence of disturbing objects is reduced to a minimum. For easy access to the transmitter make sure that it is mounted with sufficient service space.

Figure 3-1. Mounting Position

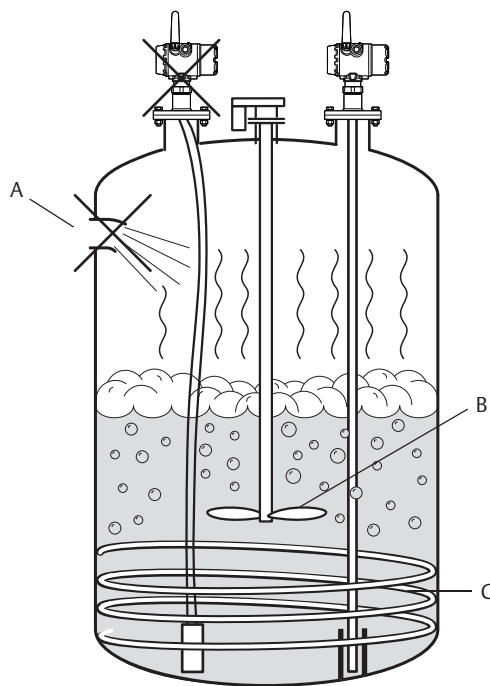

- A. Inlet pipe
- B. Agitator
- C. Heating coils

The following guidelines should be considered when mounting the transmitter:

- Do not mount close to inlet pipes.
- Do not mount close to agitators. If the probe can move to within 12 in. (30 cm) away from an agitator, the probe should be anchored. See [“Anchor the probe” on page 33](#) for more information.
- If the probe tends to sway due to turbulent conditions in the tank, the probe should be anchored. See [“Anchor the probe” on page 33](#) for more information.
- Avoid mounting close to heating coils.
- Position the probe such that it is subject to a minimum of lateral force.
- Make sure the probe does not come into contact with the nozzle or other objects in the tank.

- Make sure the nozzle does not extend into the tank.

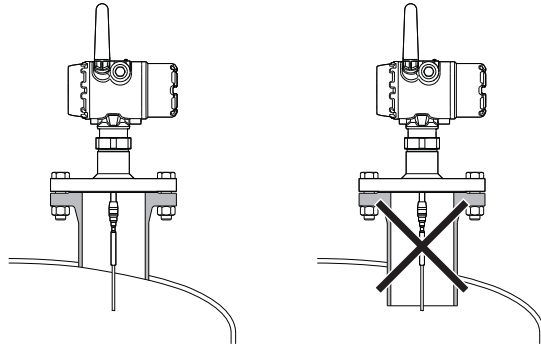

Note

Violent fluid movements causing high sideway forces may break rigid probes.

If the probe is mounted close to a wall, nozzle or other tank obstruction, noise might appear in the level signal. Therefore the following minimum clearance, according to [Table 3-1](#), must be maintained.

Figure 3-2. Free Space Requirement

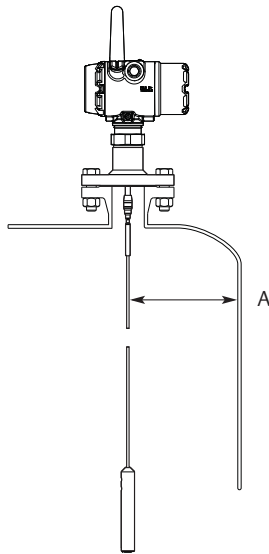

A. Clearance to tank wall

Table 3-1. Recommended Minimum Free Space to Tank Wall or Other Objects in the Tank

Probe type	Condition	Minimum clearance (A)
Rigid single/Flexible single/ Segmented rigid single lead	Smooth metal wall	4 in. (100 mm)
	Disturbing objects such as pipes and beams, or rugged metal tank walls	16 in. (400 mm)
Flexible twin	Smooth metal wall	4 in. (100 mm)
	Disturbing objects such as pipes and beams, or rugged metal tank walls	16 in. (400 mm)
Coaxial	N/A	0 in. (0 mm)

3.3.2 Flange connection on nozzles

Figure 3-3. Mounting in Nozzles

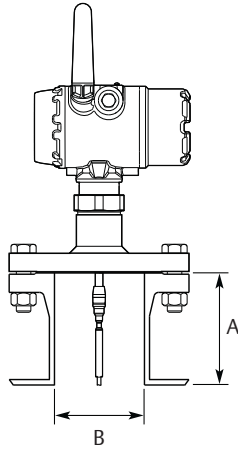

- A. Maximum nozzle height
- B. Minimum nozzle diameter

The transmitter can be mounted in nozzles by using an appropriate flange. It is recommended that the nozzle size is within the dimensions given in Table 3-2.

Note

The probe must not be in contact with the nozzle (except for the coaxial probe).

Table 3-2. Nozzle Considerations

	Flexible single lead probe	Rigid single lead probe/Segmented rigid single lead	Flexible twin lead probe	Coaxial probe
Recommended nozzle diameter	4 in. (100 mm) or more	4 in. (100 mm) or more	4 in. (100 mm) or more	> probe diameter
Minimum nozzle diameter ⁽¹⁾	1.5 in. (38 mm)	1.5 in. (38 mm) for probe type 4A 2 in. (50 mm) for probe type 4B and 4S	2 in. (50 mm)	> probe diameter
Maximum nozzle height ⁽²⁾	4 in. (100 mm) + nozzle diameter ⁽³⁾	4 in. (100 mm) + nozzle diameter	4 in. (100 mm) + nozzle diameter	N/A

1. The Trim Near Zone (TNZ) function may be necessary or an Upper Null Zone (UNZ) setup may be required to mask the nozzle.
2. Recommended maximum nozzle height. For coaxial probes there is no limitation on nozzle height.
3. For nozzles taller than 4 in. (100 mm), the Long Stud version is recommended (option code LS) to prevent the flexible portion from touching the edge of the nozzle.

3.3.3 Installation in non-metallic tanks and open-air applications

Avoid major sources of electrical disturbance in proximity of the installation, e.g. electrical motors, stirrers, servo mechanisms.

Figure 3-4. Avoid Electromagnetic Disturbances

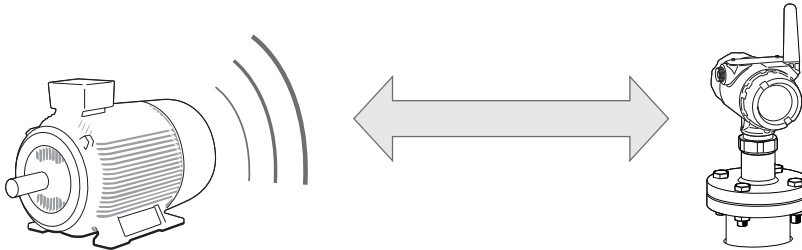

For clean liquids, use a coaxial probe to reduce effect of potential electrical disturbances.

Figure 3-5. Coaxial Probe in an Open-Air Application

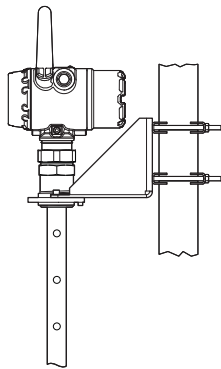

For optimal single lead probe performance in non-metallic tanks, the probe must be mounted with a metal flange, or screwed in to a metal sheet ($d > 14$ in./350 mm) if a threaded version is used.

Figure 3-6. Mounting in Non-Metallic Tanks

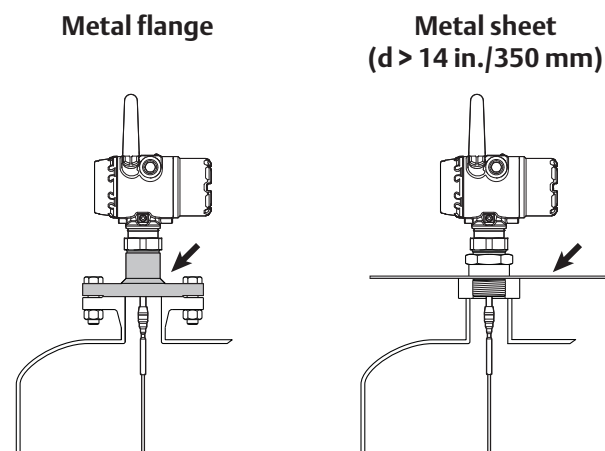

3.3.4 Installation in still pipe/chamber

General chamber considerations

A chamber or pipe installation is the preferred option due to the increase in stability and performance of the transmitter. When selecting a smaller diameter chamber or pipe (such as 2-in.) a flexible probe is not suitable due to the chance of it coming into contact with the walls, and relatively large side inlets may interfere with the signal.

When gas lift and/or turbulence may occur (e.g. boiling hydrocarbons), a 3- or 4-in. chamber/pipe diameter is recommended for maximum measurement reliability. This is especially true in high pressure and high temperature installations.

Rosemount 9901 Chamber

Rosemount 9901 allows external mounting of process level instrumentation. It supports a variety of process connections, and optional drain and vent connections. The Rosemount 9901 chamber is designed to the ASME B31.3 standard, and is Pressure Equipment Directive (PED) compliant. Use option code XC to order together with the Rosemount 3308 Series Transmitters.

Figure 3-7. Side-and-Side and Side-and-Bottom Chambers

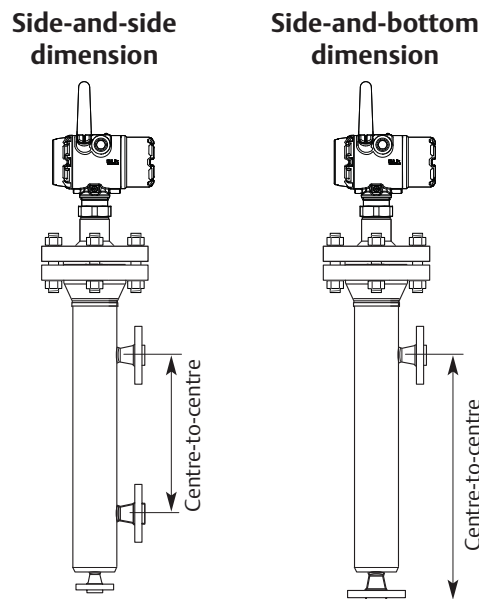

The probe length to use for a Rosemount 9901 chamber can be calculated with this formula:

Side-and-side dimension:

Probe length=Centre-to-centre dimension + 19 in. (48 cm)

Side-and-bottom dimension:

Probe length=Centre-to-centre dimension + 4 in. (10 cm)

Use a centering disc the same diameter as the chamber if the probe length >3.3 ft. (1 m). See [Table 3-5 on page 28](#) for which disc to use.

For additional information, see the Rosemount 9901 Chamber for Process Level Instrumentation [Product Data Sheet](#).

Existing chamber

A Rosemount 3308 Series Transmitter is the perfect replacement in an existing displacer chamber. Proprietary flanges are offered, enabling use of existing chambers to make installation easy.

Figure 3-8. Existing Displacer Chamber

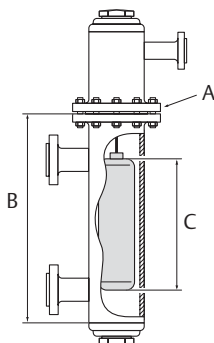

- A. Replace chamber flange
- B. Probe length
- C. Displacer Length

Considerations when changing to Rosemount 3308 Series:

- The 3308 Series flange choice and probe length must be correctly matched to the chamber. Both standard ANSI and EN (DIN), as well as proprietary chamber flanges, are available. See [Table A-19 on page 146](#) to identify the proprietary flanges.
- See [Table 3-5 on page 28](#) for guidelines on which disc size to use.
- See [Table 3-3](#) for guidelines on the required probe length.

Table 3-3. Required Probe Length in Chambers

Chamber manufacturer	Probe length ⁽¹⁾
Major torque-tube manufacture (249B, 249C, 249K, 249N, 259B)	Displacer + 9 in. (229 mm)
Masoneilan™ (Torque tube operated), proprietary flange	Displacer + 8 in. (203 mm)
Other - torque tube ⁽²⁾	Displacer + 8 in. (203 mm)
Magnetrol® (spring operated) ⁽³⁾	Displacer + between 7.8 in. (195 mm) to 15 in. (383 mm)
Others - spring operated ⁽²⁾	Displacer + 19.7 in. (500 mm)

1. If flushing ring is used, add the ring height to the probe length.
2. For other manufacturers, there are small variations. This is an approximate value, actual length should be verified.
3. Lengths vary depending on model, SG and rating, and should be verified.

For additional information, see the Replacing Displacers with Guided Wave Radar [Technical Note](#).

Probe type in chamber considerations

When installing a Rosemount 3308 in a chamber, the single lead probe is recommended. The probe length determines if a single rigid or single flexible probe should be used:

- Less than 19.7 ft. (6.0 m): Rigid single probe is recommended. Use a centering disc for probe > 3.3 ft. (1 m). When mounting space is limited, use a flexible single probe with a weight and centering disc.
- More than 19.7 ft. (6.0 m): Use flexible single probe with a weight and centering disc.

PTFE covered probes are not recommended for chamber/pipe installations.

3.4 Review mounting preparations

3.4.1 Measure tank height

The Tank Height is defined as the measured distance from the Upper Reference Point to the Zero Reference Point.

Figure 3-9. Measure Tank Height

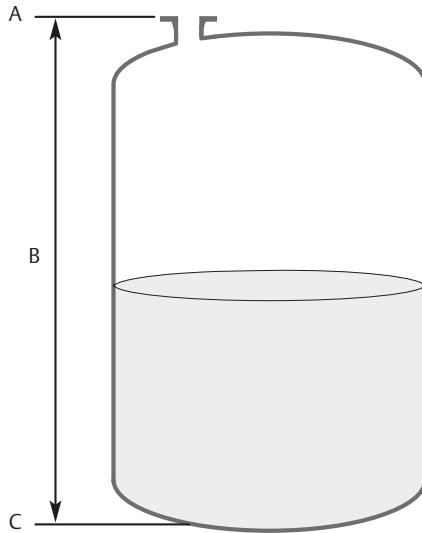

- A. Upper Reference Point
- B. Tank Height
- C. Zero Reference Point

3.4.2 Shorten the probe

In order to leave some clearance distance between the probe end and the tank bottom, the probe might have to be shortened. The goal is to have the probe hang straight so that it does not touch the wall. 2 in. (5 cm) is a suggested value. The probe can be shortened in field. Use the following form to calculate the probe length:

Probe Length = Tank height - 2 in. (5 cm)

After shortening the probe make sure to update the transmitter configuration to the new probe length, see “Probe length” on page 162.

Figure 3-10. Calculate Probe Length

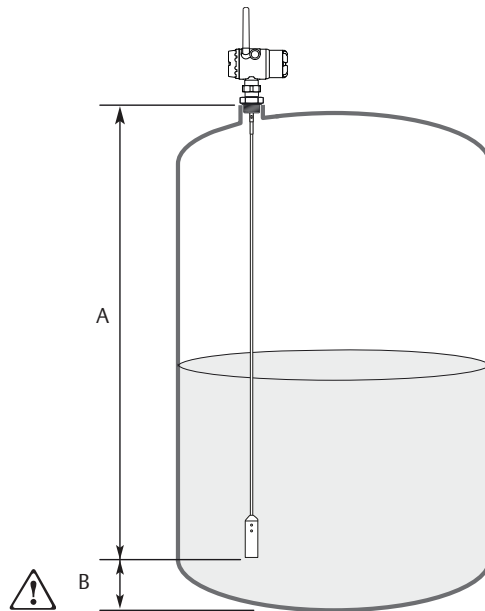

- A. Probe Length
- B. 2 in. (5 cm) clearance

Flexible single/twin lead probe

Note

The PTFE covered probes must not be cut in field.

1. Mark where to cut the probe.

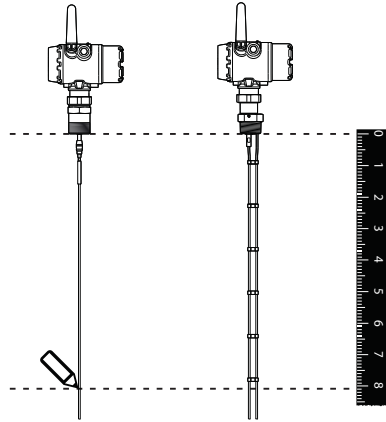

2. Remove enough spacers to make place for the weight (only flexible twin lead probes).

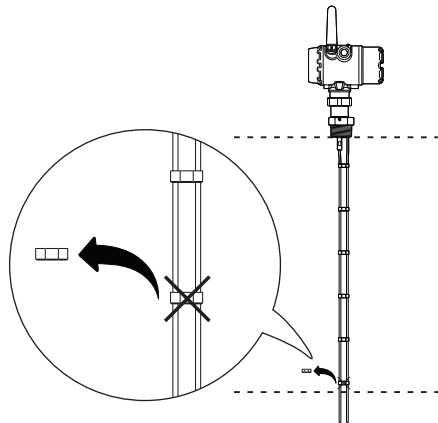

3. Loosen the weight.

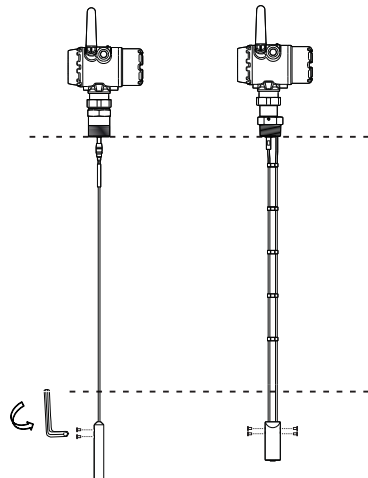

4. Slide the weight up.

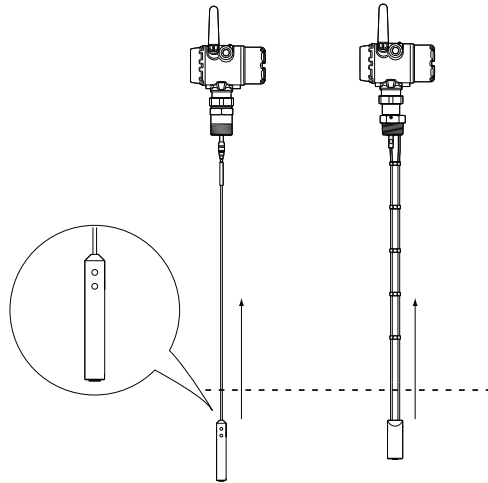

5. Cut the probe at the mark.

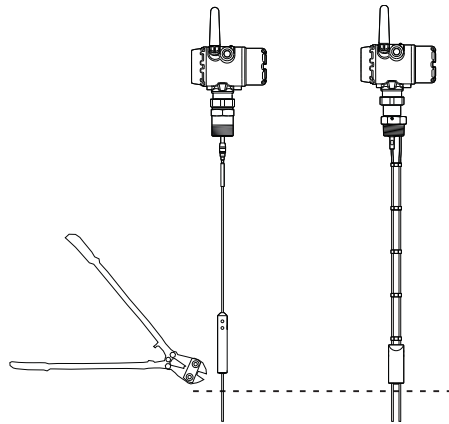

6. Fasten the weight with the following torque:

- Small weight (W1): 5 Nm
- Short weight (W2): 5 Nm
- Heavy weight (W3): 5 Nm
- Weight, flexible twin: 6 Nm

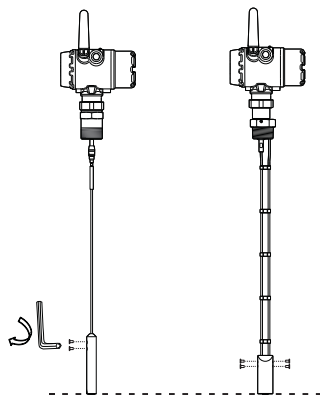

Rigid single lead probe

Note

The PTFE covered probes must not be cut in field.

Note

Make sure the lead is fixed while cutting.

1. Mark where to cut the probe.

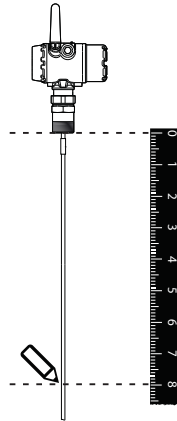

2. Cut the probe at the mark.

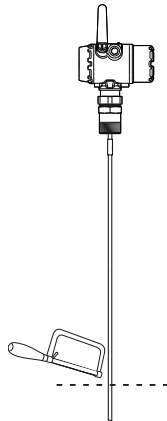

Coaxial probe

1. Mark where to cut the probe.
2. Insert the centering piece.
(The centering piece is delivered from factory and should be used to prevent the spacers centering the rod from coming loose).
3. Cut the tube to the desired length.
4. Move the centering piece.

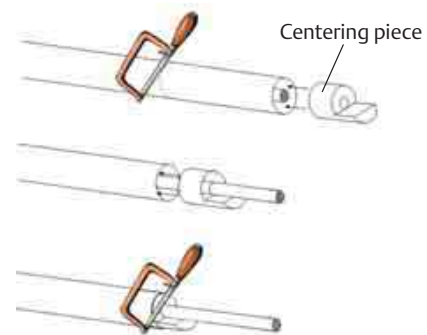

5. Cut the rod inside the tube. Make sure the rod is fixed with the centering piece while cutting.
 - Pipes longer than 49 in. (1250 mm) can be shortened by as much as 23.6 in. (600 mm).

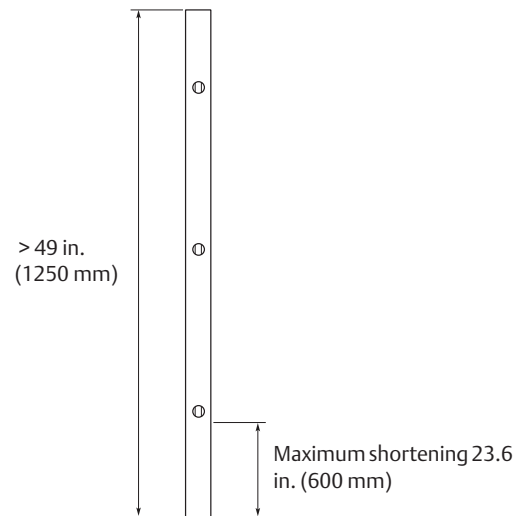

- Pipes shorter than 49 in. (1250 mm) can be cut as long as the remaining length is not less than 15.7 in. (400 mm).

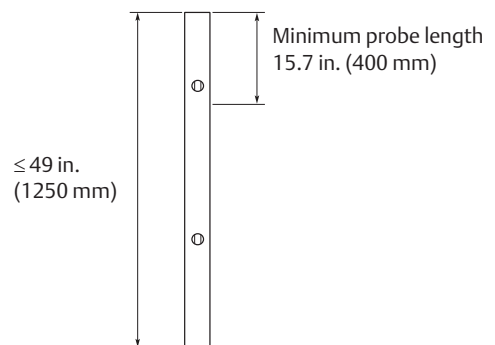

3.4.3 Mount a centering disc for pipe installations

To prevent the probe from contacting the chamber or pipe wall, centering discs are available for flexible single, rigid single, and flexible twin lead probes. The disc is attached to the end of the probe. Discs are made of stainless steel, Alloy C-276, Duplex 2205, or PTFE.

When mounting a centering disc, it is important that it fits correctly in the chamber/pipe. See [Table 3-4](#) for Dimension D. [Table 3-5](#) shows which centering disc diameter to choose for a particular pipe.

Figure 3-11. Dimension D for Centering Discs

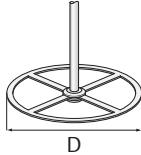

Table 3-4. Centering Discs Dimensions

Disc size	Actual disc diameter (D)
2-in.	1.8 in. (45 mm)
3-in.	2.7 in. (68 mm)
4-in.	3.6 in. (92 mm)
6-in.	5.55 in. (141 mm)
8-in.	7.40 in. (188 mm)

Table 3-5. Centering Disc Size Recommendation for Different Pipe Schedules

Pipe size	Pipe schedule			
	5s, 5 and 10s, 10	40s, 40 and 80s, 80	120	160
2-in.	2-in.	2-in.	N/A ⁽¹⁾	N/A ⁽²⁾
3-in.	3-in.	3-in.	N/A ⁽¹⁾	2-in.
4-in.	4-in.	4-in.	4-in.	3-in.
5-in.	4-in.	4-in.	4-in.	4-in.
6-in.	6-in.	6-in.	4-in.	4-in.
7-in.	N/A ⁽¹⁾	6-in.	N/A ⁽¹⁾	N/A ⁽¹⁾
8-in.	8-in.	8-in.	6-in.	6-in.

- Schedule is not available for pipe size.
- No centering disc is available.

Flexible single/twin lead probe

1. Mount the centering disc at the end of the weight.

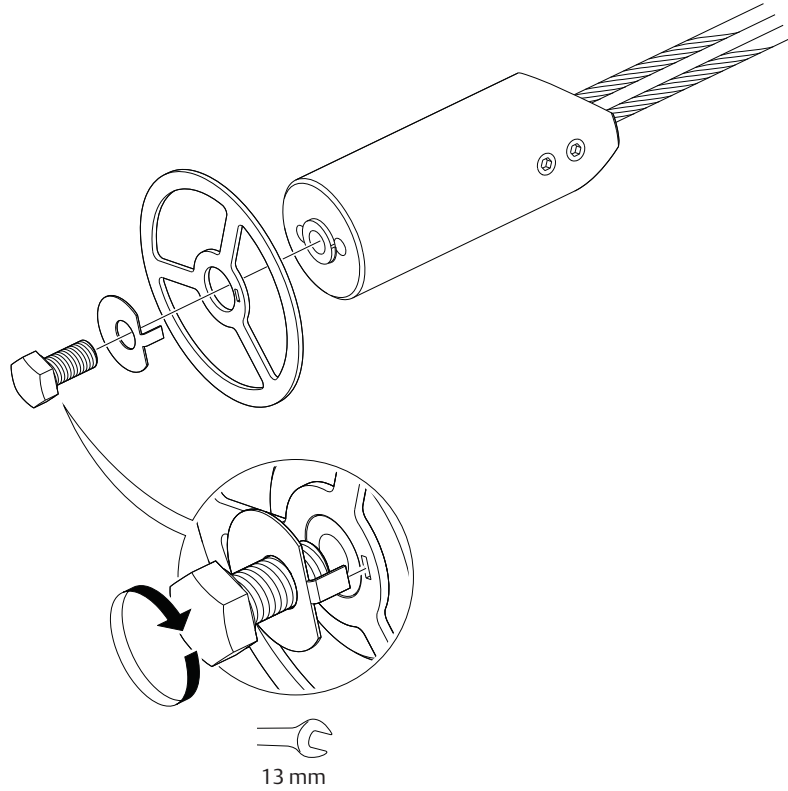

2. Secure the bolt by folding the tab washer.

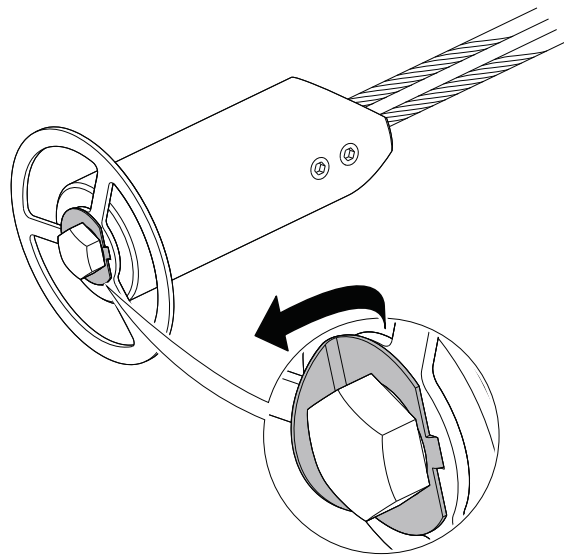

Rigid single lead probe (8 mm)

Note

Centering discs shall not be used with PTFE covered probes.

1. Drill one hole using the drilling fixture (included in your shipment).

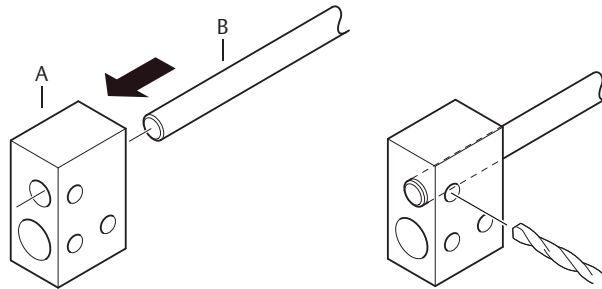

A. Drilling fixture
B. Probe

2. Mount the bushing, centering disc, and washer at the probe end.

Note

Do not mount the washer if the centering disc material is PTFE.

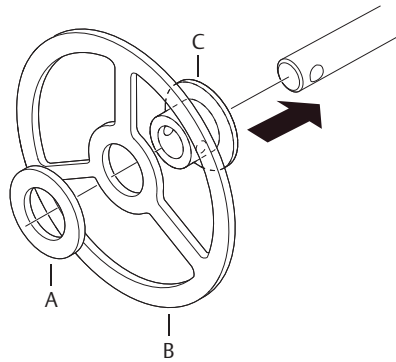

A. Washer
B. Centering disc
C. Bushing

3. Insert the split pin through the bushing and the probe.

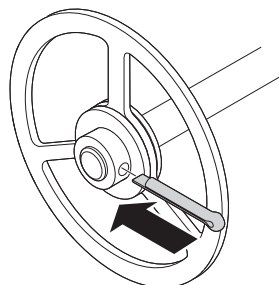

- Secure the split pin.

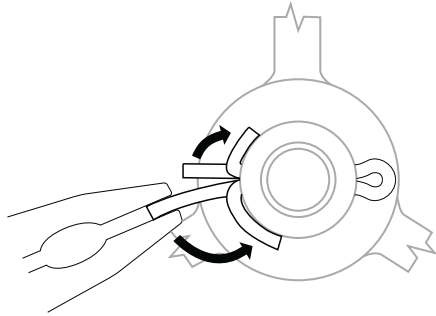

Rigid single lead probe (13 mm)

- Drill two holes using the drilling fixture (included in your shipment).

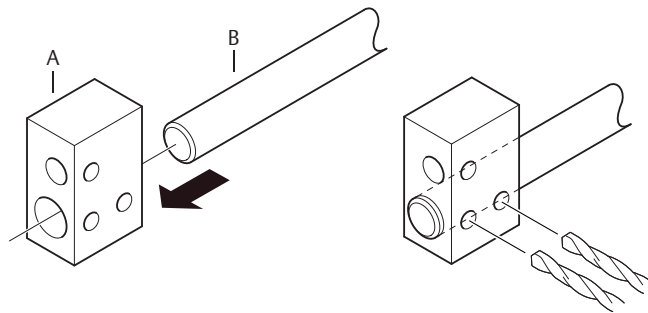

- A. Drilling fixture
- B. Probe

- Mount the bushings and centering disc at the probe end.

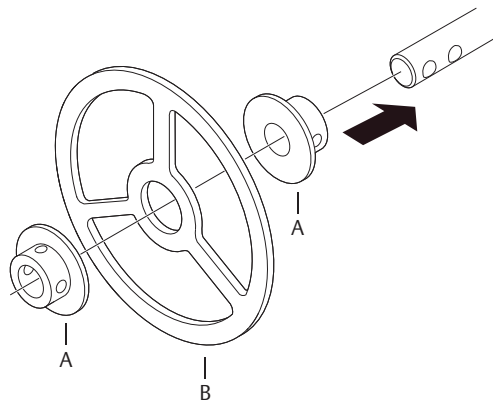

- A. Bushing
- B. Centering disc

3. Adjust distance by shifting hole for split pin in lower bushing.

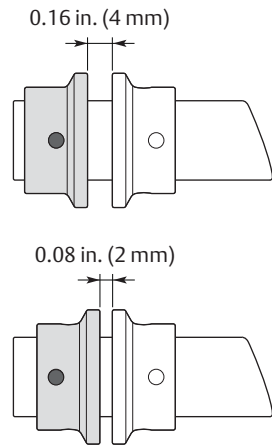

4. Insert the split pins through the bushings and the probe.

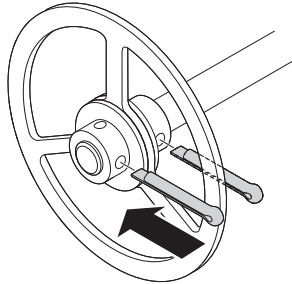

5. Secure the split pins.

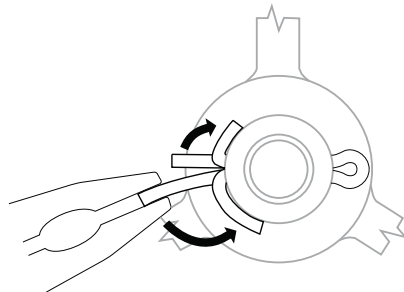

3.5 Anchor the probe

In turbulent tanks it may be necessary to fix the probe. Depending on the probe type, different methods can be used to guide the probe to the tank bottom. This may be needed in order to prevent the probe from hitting the tank wall or other objects in the tank, as well as preventing a probe from breaking.

3.5.1 Flexible single/twin lead probe

The flexible single lead probe itself can be used for anchoring. Pull the probe rope through a suitable anchoring point, e.g. a welded eye, and fasten it with a chuck.

The length of the loop will add to the Blind Zone. The location of the chuck will determine the beginning of the Blind Zone. See “Accuracy over measuring range” on page 114 for further information on Blind Zones.

The Probe Length should be configured as the distance from the Upper Reference Point to the top of the chuck.

Figure 3-12. Flexible Single Lead Probe with Chuck

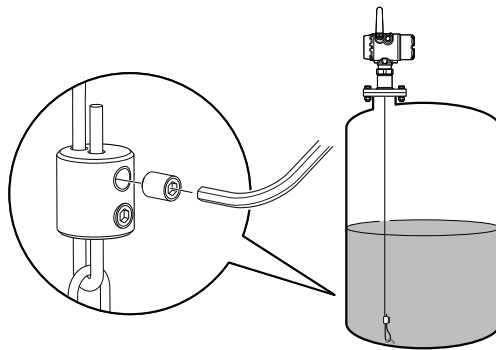

A ring (customer supplied) can be attached to the weight in a threaded (M8x14) hole at the end of the weight. Attach the ring to a suitable anchoring point.

Figure 3-13. Flexible Twin/Single Lead Probe with Weight and Ring

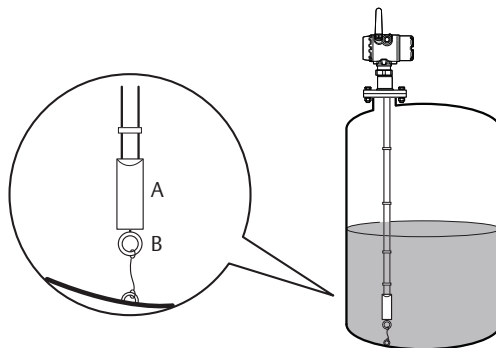

- A. Weight with internal threads M8x14
- B. Ring

A magnet (customer supplied) can be fastened in a threaded (M8x14) hole at the end of the weight. The probe can then be guided by placing a suitable metal plate beneath the magnet.

Figure 3-14. Flexible Twin/Single Lead Probe with Weight and Magnet

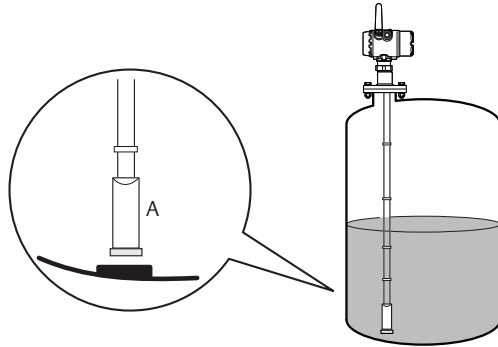

A. Magnet

3.5.2 Rigid single lead probe

The rigid single lead probe can be guided by a tube welded on the tank bottom. Tubes are customer supplied. Make sure that the probe can move freely in order to handle thermal expansion. The measurement accuracy will be reduced close to the tube opening.

Figure 3-15. Rigid Single Lead Probe with Tube

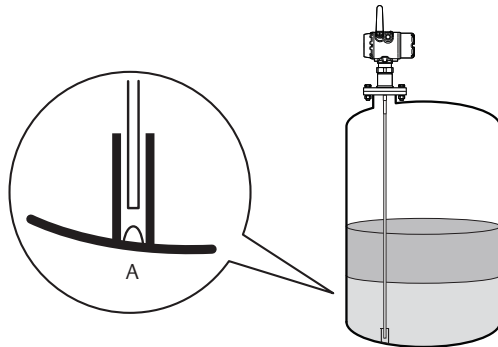

A. Drain

3.5.3 Coaxial probe

The coaxial probe can be secured to the tank wall by fixtures fastened to the tank wall. Fixtures are customer supplied. Make sure the probe can move freely due to thermal expansion without getting stuck in the fixture.

Figure 3-16. Coaxial Probe Secured to the Tank Wall

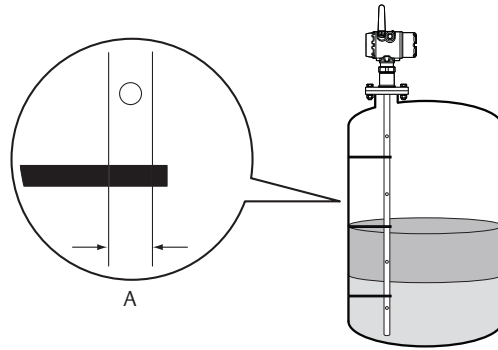

A. 1.1 in. (28 mm)

The coaxial probe can be guided by a tube welded on the tank bottom. Tubes are customer supplied. Make sure that the probe can move freely in order to handle thermal expansion. The measurement accuracy will be reduced close to the tube opening.

Figure 3-17. Coaxial Probe with Tube

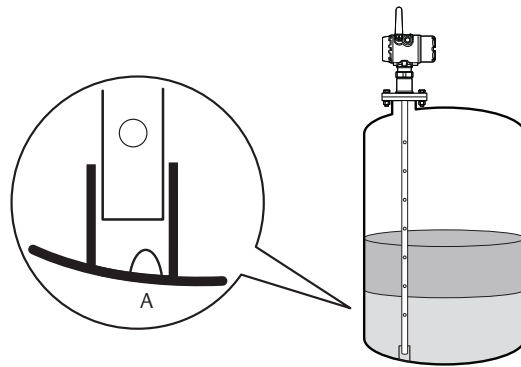

A. Drain

3.6 Mount device on tank

Mount the transmitter with flange on a nozzle on top of the tank. The transmitter can also be mounted on a threaded connection. Make sure only qualified personnel perform the installation.

Note

If the transmitter head must be removed from the probe, make sure that the process seal is carefully protected from dust and water. See “Transmitter head replacement” on page 108 for further information.

Note

PTFE covered probes must be handled carefully to prevent damage to the coating.

3.6.1 Threaded tank connection

1. For adapters with BSPP (G) threads, place a gasket on top of the tank flange.

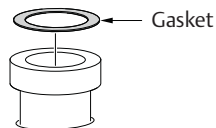

2. For adapters with NPT threads, use anti-seize paste or PTFE tape according to your site procedures.

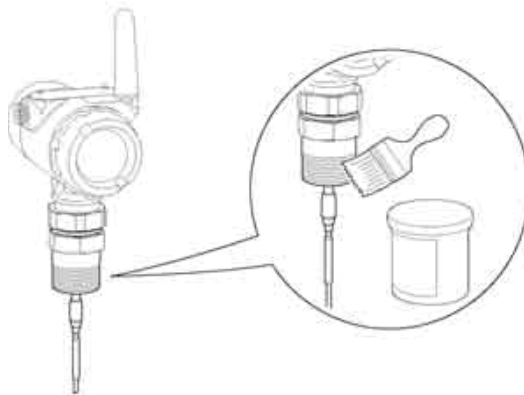

3. Lower the transmitter and probe into the tank.

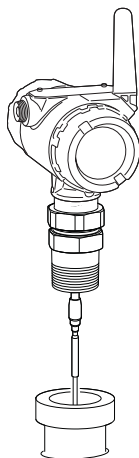

4. Loosen the nut that connects the transmitter head to the probe slightly.

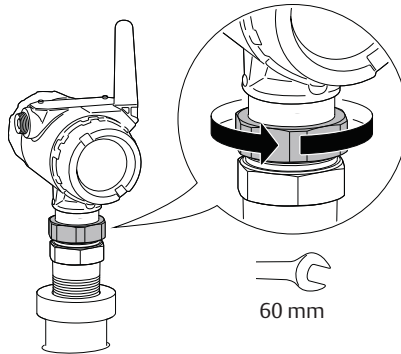

5. Screw the adapter into the process connection.

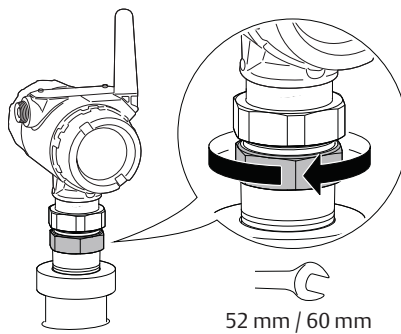

6. Rotate the transmitter head so the device display faces the desired direction.

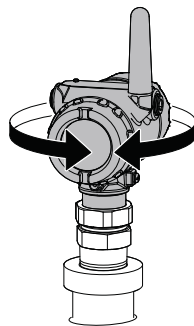

7. Tighten the nut.

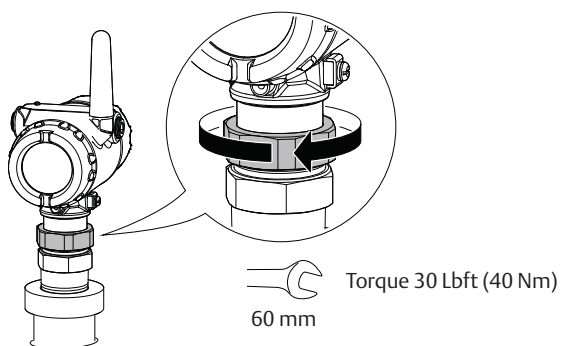

8. Continue with the grounding step.

3.6.2 Tank connection with flange

1. Place a gasket on top of the tank flange.

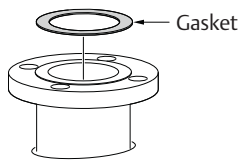

Note

Gasket should not be used for PTFE covered probe with protective plate.

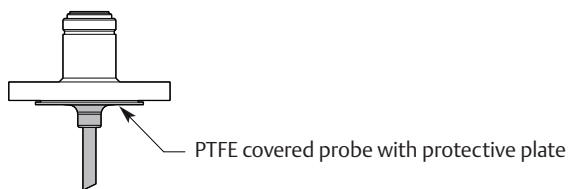

2. Lower the transmitter and probe with flange into the tank.

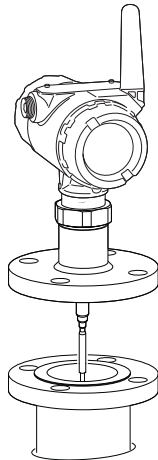

3. Tighten bolts and nuts with sufficient torque for the flange and gasket choice.

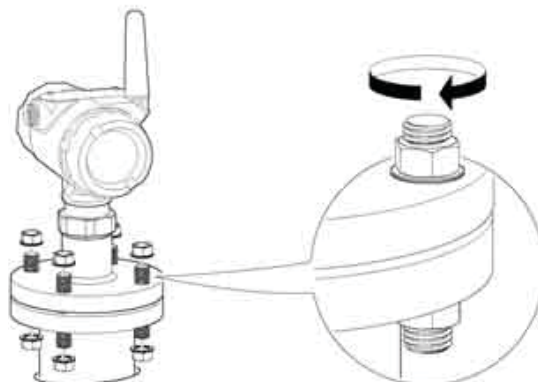

4. Loosen the nut that connects the transmitter head to the probe slightly.

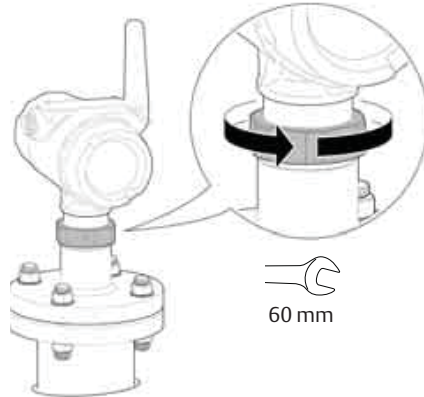

5. Rotate the transmitter head so the device display faces the desired direction.



6. Tighten the nut.

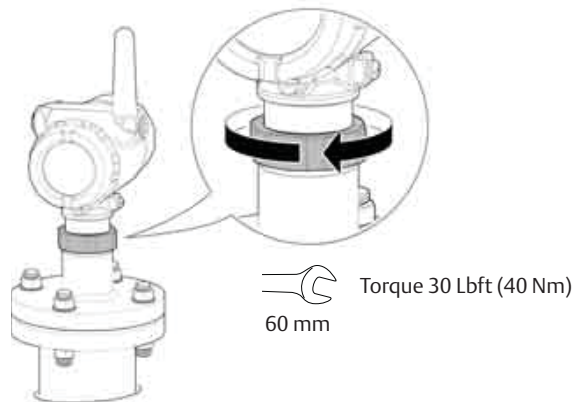

7. Continue with the grounding step.

3.6.3 Tank connection with loose flange (“plate design”)

The transmitter is delivered with head, flange and probe assembled into one unit. If, for some reason, these parts have been disassembled, mount the transmitter as described below:

1. Mount the flange on the probe and tighten the flange nut.

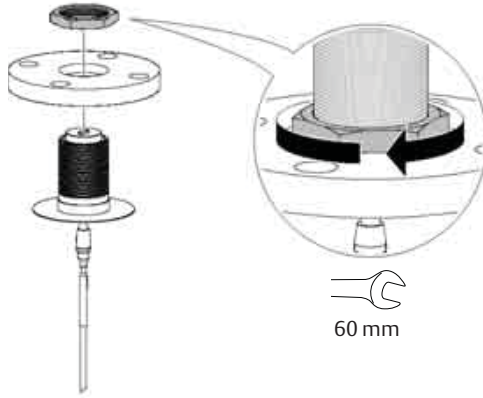

2. Place a gasket on top of the tank flange.

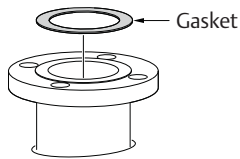

3. Lower the probe with flange into the tank.

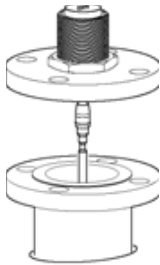

4. Tighten bolts and nuts with sufficient torque for the flange and gasket choice.

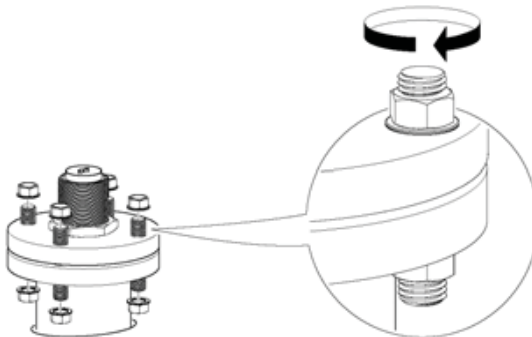

5. Mount the transmitter head.

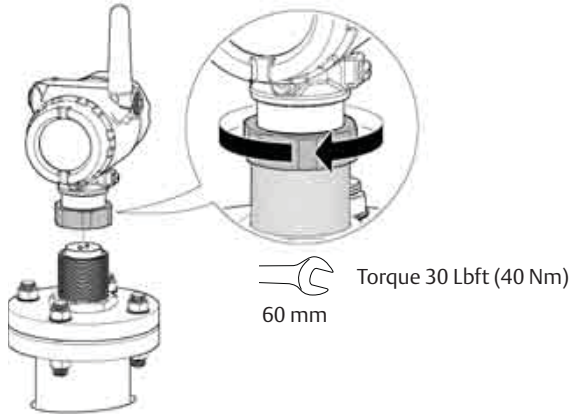

6. Continue with the grounding step.

3.6.4 Tank connection with Tri Clamp

1. Place a gasket on top of the tank flange.

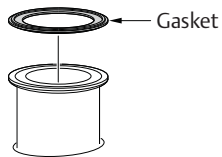

2. Lower the transmitter and probe into the tank.

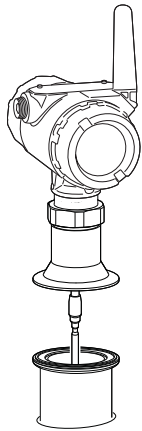

3. Fasten the Tri Clamp to the tank with a clamp.

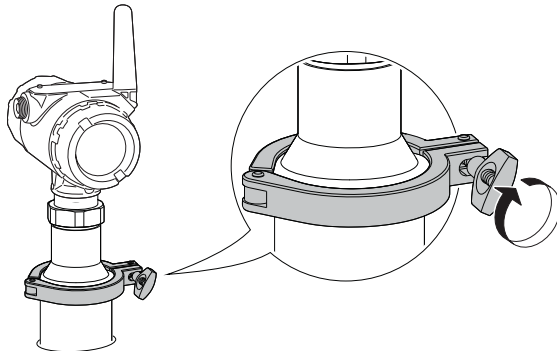

- Loosen the nut that connects the transmitter head to the probe slightly.

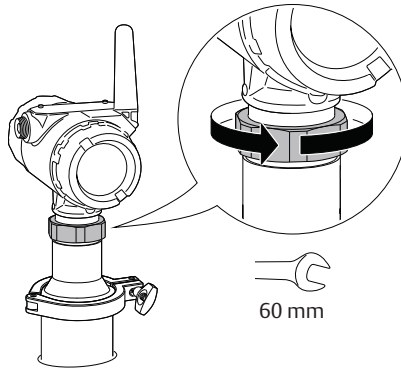

- Rotate the transmitter head so the device display faces the desired direction.

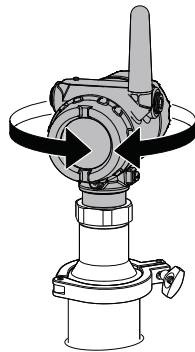

- Tighten the nut.

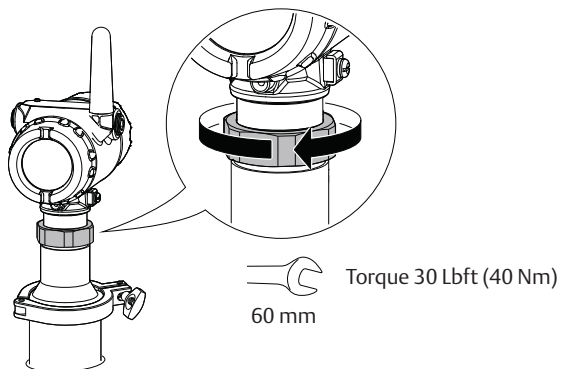

- Continue with the grounding step.

3.6.5 Segmented probe

Figure 3-18. Segmented Probe Parts

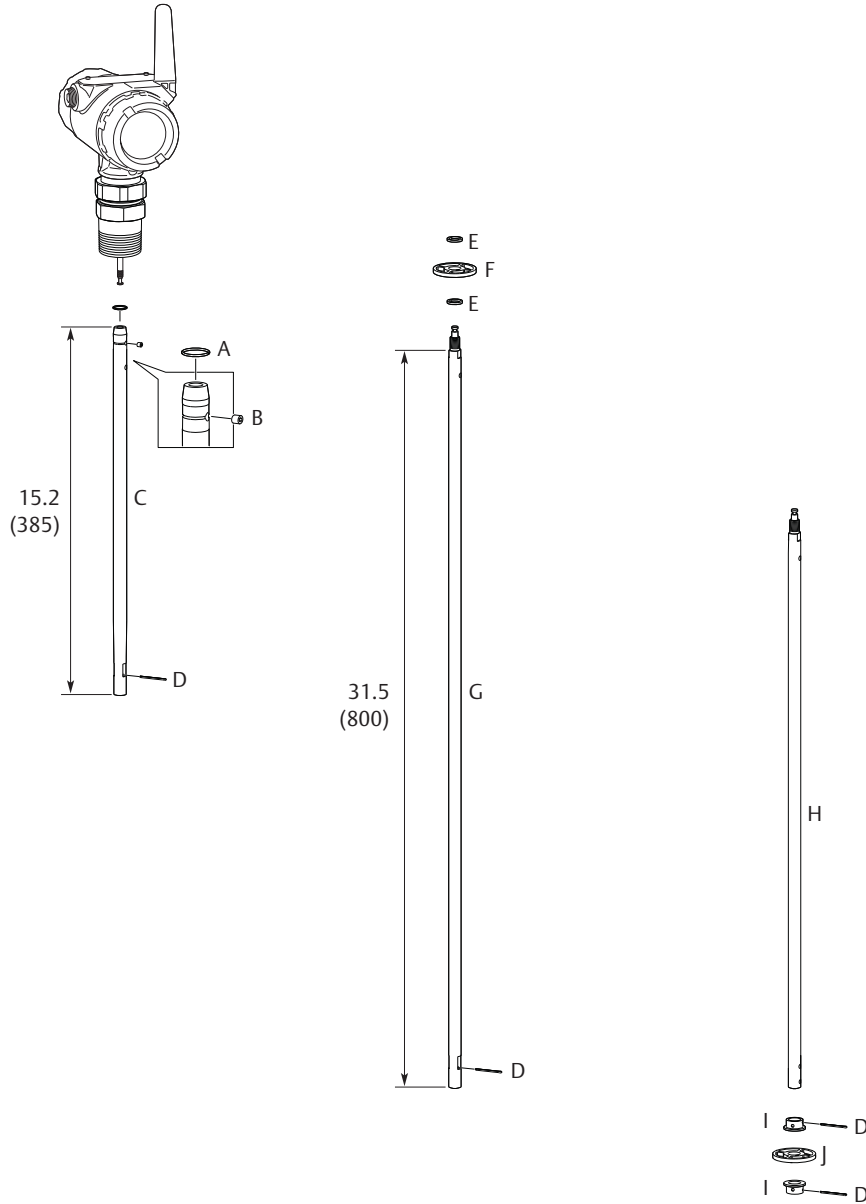

Dimensions are in inches (mm).

- A. Safety ring
- B. Screw
- C. Top segment
- D. Split pin
- E. PTFE washer (optional)
- F. Centering disc in PTFE (optional)
- G. Middle segment
- H. Bottom segment (length varies depending on total probe length)
- I. Bushing (for the centering disc at the probe end)
- J. Bottom centering disc in PTFE or stainless steel (optional)

Verify probe length

Segmented probe ordered with model code 4S

Before installation, verify the probe length (L) on the label. If the probe length needs to be adjusted, see “Adjusting the probe length” on page 51.

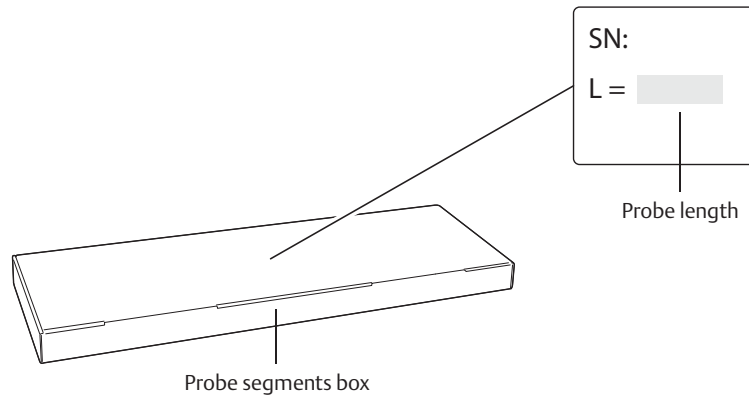

Segmented probe ordered as spare part kit

Before installation, the number of segments that add up to the desired probe length must be determined. Also, the bottom segment may need to be shortened. See “Adjusting the probe length” on page 51.

Assemble the segmented probe

Note

If there is enough space beside the tank, the probe can be assembled before inserting it into the tank.

1. Insert the stop screw to the top segment. Tighten approximately two turns.

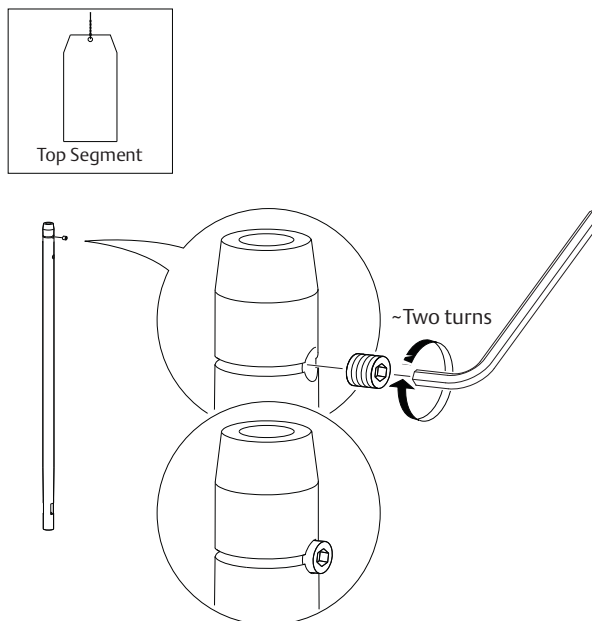

2. Pre-assemble the safety ring.

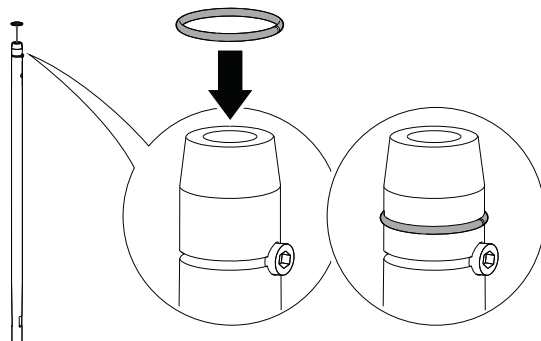

3. **Optional:** If ordered, mount the centering disc on the bottom segment of the probe.

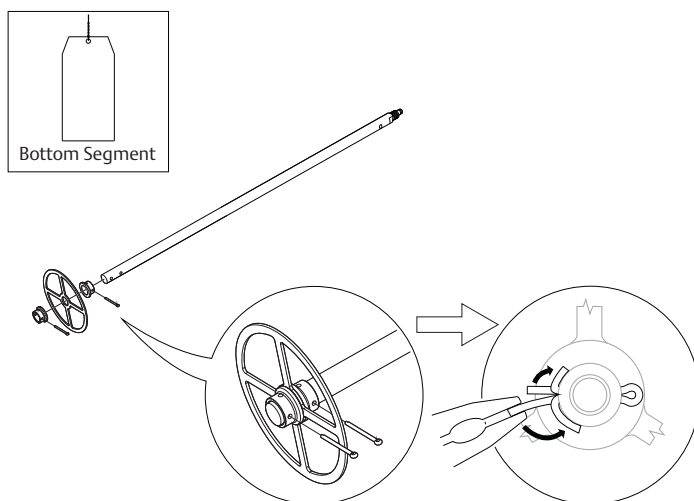

4. Insert the support tool.

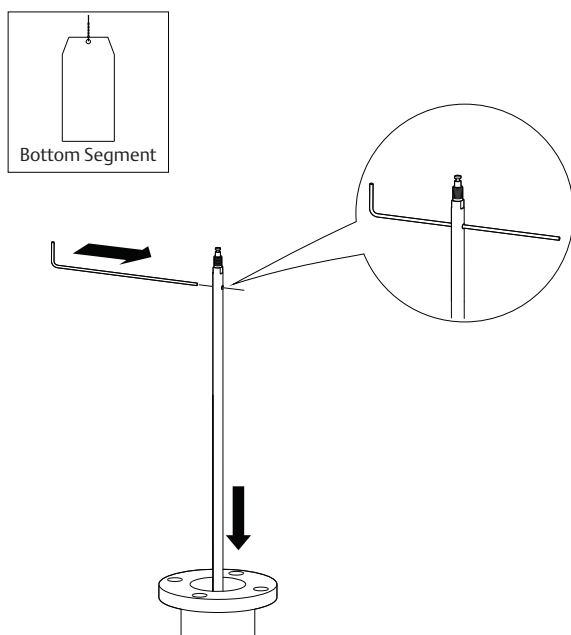

5. **Optional:** If ordered, mount the centering disc.

Note

- Maximum five pcs/probe
- Minimum two segments between each centering disc

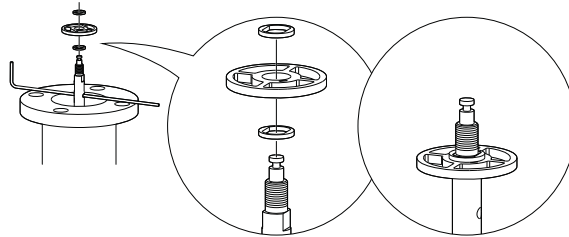

6. Mount a middle segment.

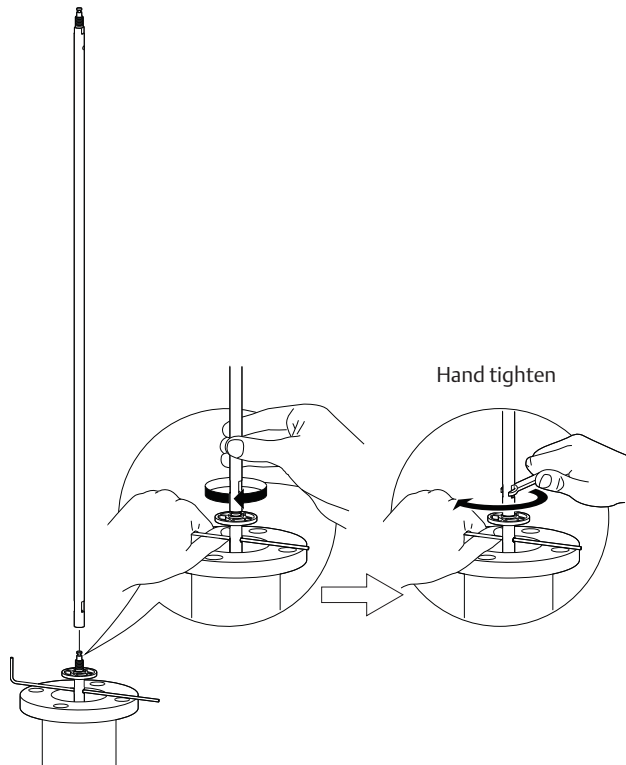

7. Secure the split pin.

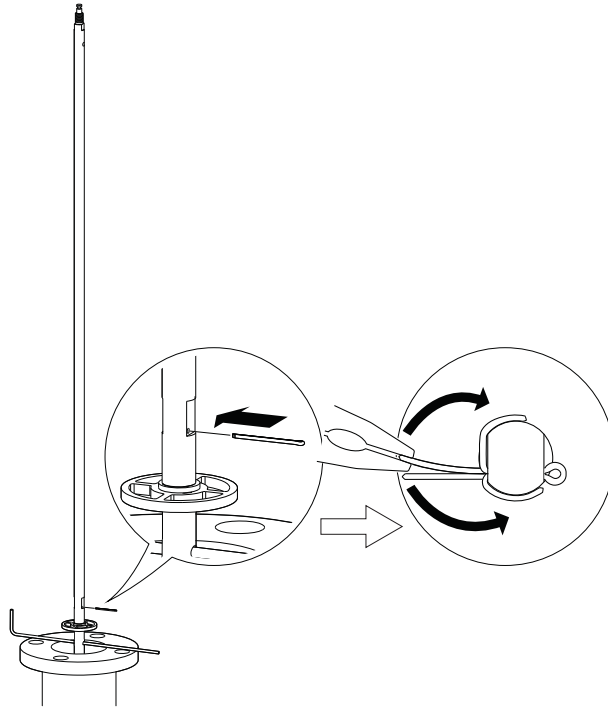

8. Insert the second support tool.

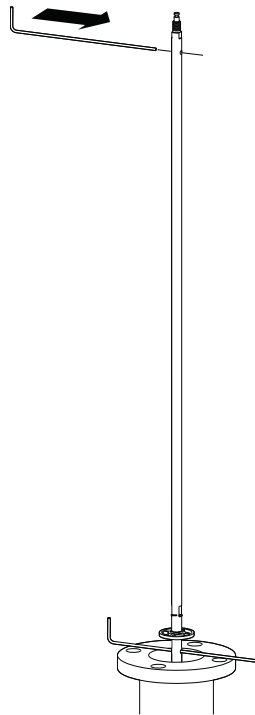

9. Remove the first support tool and lower the probe into the tank.

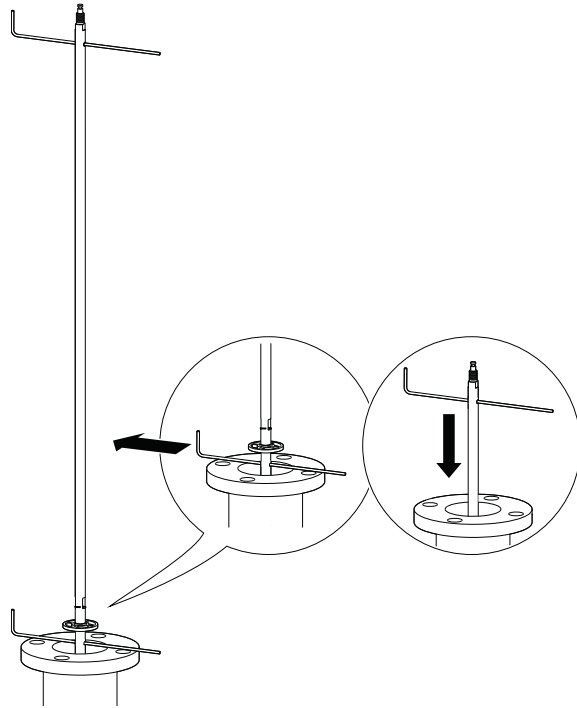

10. Repeat steps 5 to 9 until all segments are mounted. Make sure to finish with the top segment of the probe.
11. Seal and protect threads.

⚠ Only for NPT threaded tank connection.

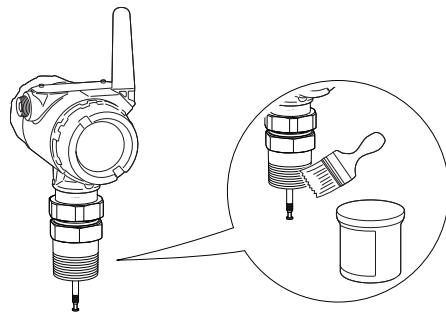

Use anti-seize paste or PTFE tape according to your site procedures.

12. Attach the probe to the device.

Flange/Tri Clamp

Threaded

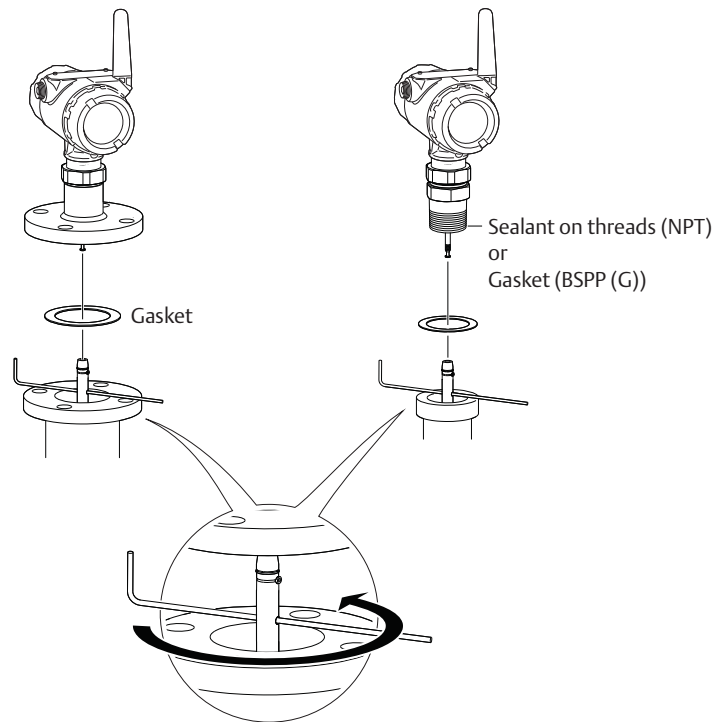

Note

For safety reasons, at least two people are needed when mounting the device. Make sure to hold the device above the tank. High loads can break the support tool.

13. Tighten the stop screw and slide the safety ring into the groove.

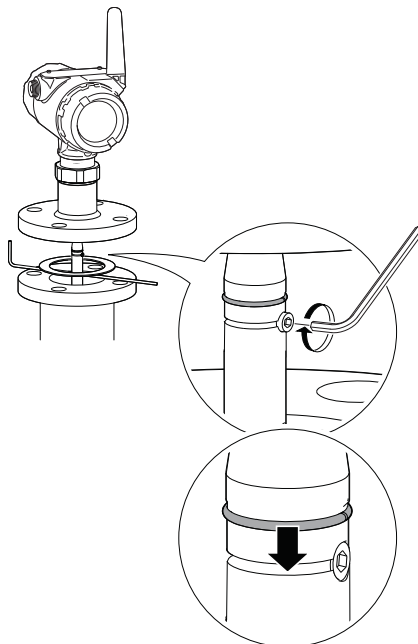

14. Remove the support tool.

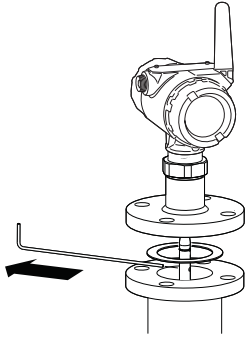

15. Mount the device on the tank.

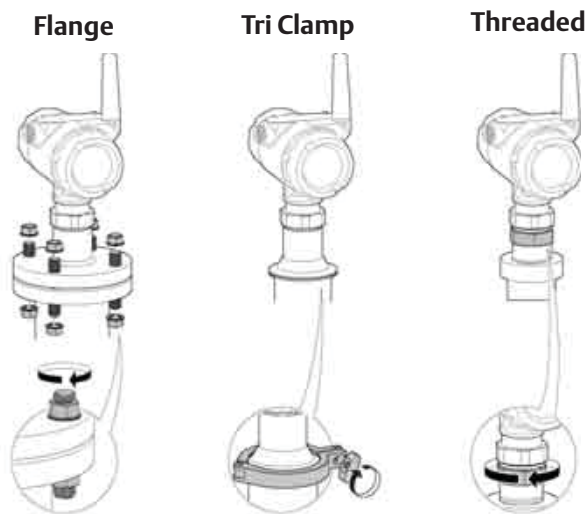

16. Rotate the housing to the desired direction.

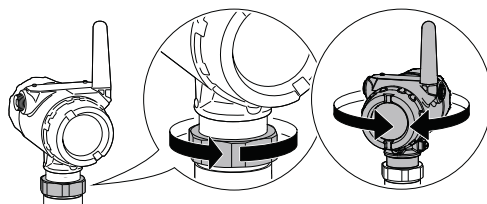

17. Tighten the nut.

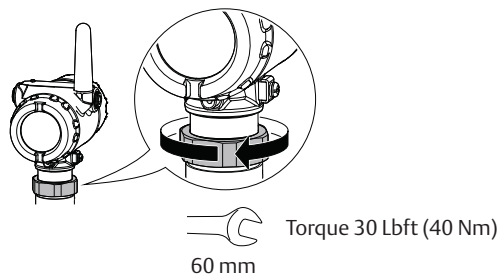

18. Continue with the grounding step.

Adjusting the probe length

- Determine L , the desired probe length.

L, desired probe length:

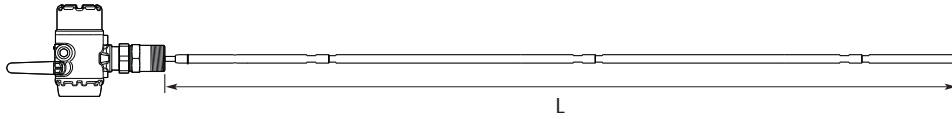

- Determine n , the number of middle segments needed for the desired probe length. See [Table 3-6 on page 53](#).

n, number of middle segments:

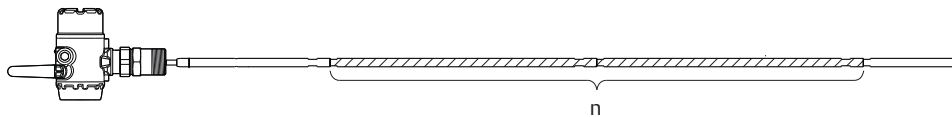

- Calculate Y , the length of the bottom segment. See [Table 3-6 on page 53](#).

Y, length of bottom segment:



- Continue as follows:

Length of bottom segment (Y)	Action
<p>$Y < 0.4 \text{ in. (10 mm)}$</p>	<ul style="list-style-type: none"> Continue with step (7). Do not use the bottom segment.
<p>$Y \geq 0.4 \text{ in. (10 mm)}$</p>	<ul style="list-style-type: none"> Continue with step (5) and cut the bottom segment.
<p>$Y = 31.5 \text{ in. (800 mm)}$</p>	<ol style="list-style-type: none"> Add one extra middle segment to the calculated n. Continue with step (7).

5. Mark where to cut the bottom segment.

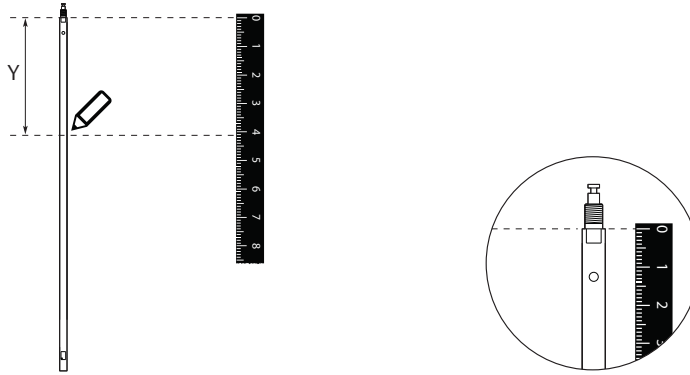

6. Cut the bottom segment at the mark.

Note

Make sure the bottom segment is fixed while cutting.

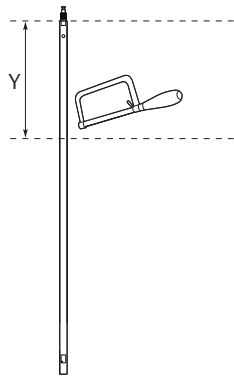

7. **Optional:** If a bottom centering disc is ordered, then drill two holes on the bottom segment using the drilling fixture.

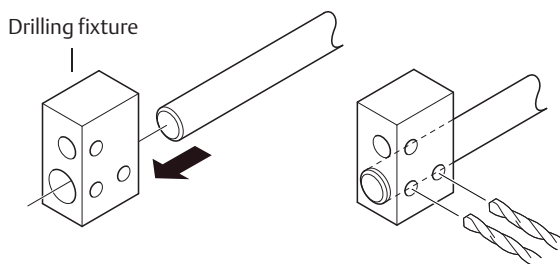

Table 3-6. Determination of Probe Segments for Standard Seal

Desired probe length (L) ⁽¹⁾		Number of middle segments (n)	Length of bottom segment (Y)	
in.	mm		in.	mm
15.8 ≤ L ≤ 47.2	400 ≤ L ≤ 1200	0 pc	Y = L - 15.8	Y = L - 400
47.2 < L ≤ 78.7	1200 < L ≤ 2000	1 pc	Y = L - 47.2	Y = L - 1200
78.7 < L ≤ 110.2	2000 < L ≤ 2800	2 pcs	Y = L - 78.7	Y = L - 2000
110.2 < L ≤ 141.7	2800 < L ≤ 3600	3 pcs	Y = L - 110.2	Y = L - 2800
141.7 < L ≤ 173.2	3600 < L ≤ 4400	4 pcs	Y = L - 141.7	Y = L - 3600
173.2 < L ≤ 204.7	4400 < L ≤ 5200	5 pcs	Y = L - 173.2	Y = L - 4400
204.7 < L ≤ 236.2	5200 < L ≤ 6000	6 pcs	Y = L - 204.7	Y = L - 5200
236.2 < L ≤ 267.7	6000 < L ≤ 6800	7 pcs	Y = L - 236.2	Y = L - 6000
267.7 < L ≤ 299.2	6800 < L ≤ 7600	8 pcs	Y = L - 267.7	Y = L - 6800
299.2 < L ≤ 330.7	7600 < L ≤ 8400	9 pcs	Y = L - 299.2	Y = L - 7600
330.7 < L ≤ 362.2	8400 < L ≤ 9200	10 pcs	Y = L - 330.7	Y = L - 8400
362.2 < L ≤ 393.7	9200 < L ≤ 10000	11 pcs	Y = L - 362.2	Y = L - 9200

1. Maximum probe length is 32 ft. 9 in. (10 m) for the Rosemount 3308 Series.

3.7 Ground the device

The Rosemount 3308 Series Wireless Guided Wave Radar transmitter operates with the housing grounded or floating. Floating systems can cause extra noise that may affect many types of readout devices. If the signal appears noisy or erratic, grounding at a single point may solve the problem.

Grounding of the electronics enclosure should be done in accordance with local and national installation codes. Grounding is accomplished by using the external case grounding terminal.

Non-metallic tanks

Ground device on non-metallic tanks (e.g. fiberglass tanks) to prevent electrostatic charge build-up.

There is one grounding screw connection provided, located on the housing, see [Figure 3-19](#). The ground screw is identified by a ground symbol: 

Figure 3-19. Ground Screw



A. Ground screw

Note

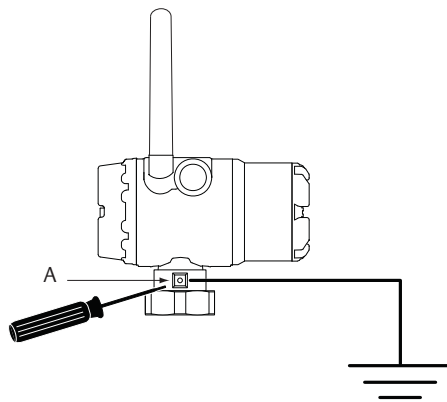
Always use facility recommended wiring practices.

Note

Flexible twin lead probe or coaxial probe are the recommended choice for non-metallic tanks. Single lead probes are not suited for non-metallic tanks or open atmosphere applications, due to high susceptibility to strong electromagnetic fields.

3.8 Install the power module

Note

Use caution when handling the power module, it may be damaged if dropped from heights in excess of 20 ft. (6 m).

1. Install the Black Power Module, SmartPower™ Solutions model number 701PBKKF into the transmitter.

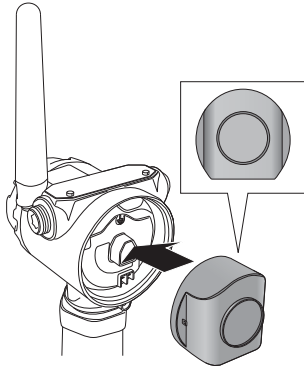

2. Close the housing cover and tighten to site or safety specifications. Always ensure a proper seal by tightening the electronics housing covers so that metal touches metal, but do not over tighten.

Keep cover tight

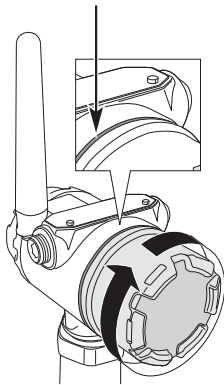

3.9 Position the antenna

The antenna should be positioned vertically, either straight up or straight down, and it should be approximately 3 ft. (1 m) from any large structure, building, or conductive surface to allow for clear communication to other devices.

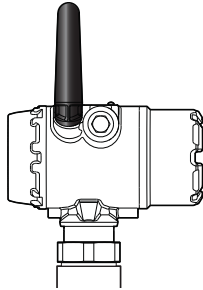
Figure 3-20. Antenna Positioned Vertically

3.10 Utilize the device display

If a device display is ordered, it will be shipped attached to the transmitter. The display is ordered in the transmitter model number, option code M5.

3.10.1 Rotate the device display

To rotate the display in 90-degree increments:

1. Squeeze the two black tabs on opposite sides of the display. Refer to [Figure 3-21](#).
2. Gently pull out the display.
3. Rotate the display to the desired orientation, and snap the display into place.

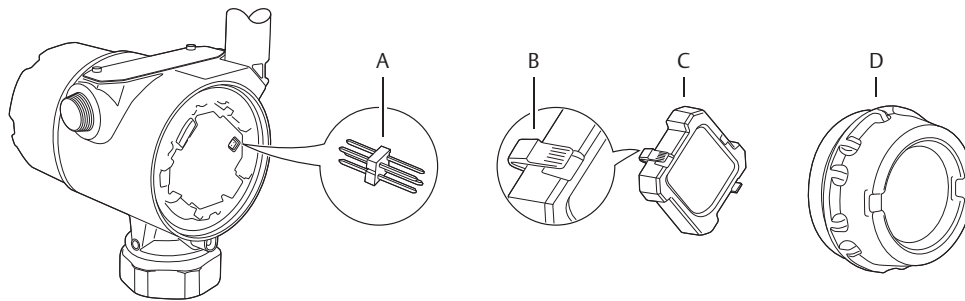
Figure 3-21. Device Display

- A. Display Pins
- B. Black tabs
- C. Display
- D. Cover

Note

If the device display four-pin connector is inadvertently removed from the interface board, carefully re-insert the connector before snapping the device display back into place.

3.10.2 Retrofitting

If an existing transmitter with no display (flat electronics cover) is to be retrofitted with a new display, order spare part kit number 00753-9004-0001 (aluminum display kit) or 00753-9004-0004 (stainless steel display kit). These kits contain an extended cover with a display viewing window, a display board, and a display pin connector. Replace the flat cover with the extended display and tighten.

Section 4 Configuration

Overview	page 57
Safety messages	page 58
Configuration procedure	page 59
System readiness	page 60
Get started with your preferred configuration tool	page 61
Join device to wireless network	page 64
Configure device using guided setup	page 72
Verify level	page 74

4.1 Overview

This chapter provides information about configuration, configuration tools, and configuration parameters.

- For a proper configuration, follow the steps listed in the section “[Configuration procedure](#)” on [page 59](#).
- The configuration can be performed using one of the described configuration tools: AMS Wireless Configurator or a Field Communicator. The section “[Get started with your preferred configuration tool](#)” on [page 61](#) describes what preparations must be done in order to use the configuration tool.
- [Appendix D: Configuration Parameters](#) provides extended information about the configuration parameters. An overview of Device Descriptor (DD) menu is presented in the section “[Menu overview of the Device Descriptor \(DD\)](#)” on [page 160](#). All configuration parameters are described in section “[Configuration parameters](#)” on [page 161](#).

4.2 Safety messages

Instructions and procedures in this section may require special precautions to ensure the safety of the personnel performing the operations. Information that potentially raises safety issues is indicated by a warning symbol (⚠). Refer to the following safety messages before performing an operation preceded by this symbol.

⚠ WARNING

Explosions could result in death or serious injury.

- Verify that the operating environment of the gauge is consistent with the appropriate hazardous locations certifications.
- Installation of device in an explosive environment must be in accordance with appropriate local, national and international standards, codes, and practices.
- Ensure device is installed in accordance with intrinsically safe or non-incendive field practices.

Electrical shock can result in death or serious injury.

- Ground device on non-metallic tanks (e.g. fiberglass tanks) to prevent electrostatic charge build-up.
- Single lead probes are sensitive for strong electromagnetic fields and therefore not suitable for non-metallic tanks.
- Care must be taken during transportation of power module to prevent electrostatic charge build-up.
- Device must be installed to ensure a minimum antenna separation distance of 8 in. (20 cm) from all persons.

Process leaks could result in death or serious injury.

- Only qualified personnel should install the equipment.
- Handle the transmitter carefully.
- If the process seal is damaged, gas could escape from the tank when removing the transmitter head from the probe.

⚠ WARNING

To ensure long life for your radar transmitter, and to comply with hazardous location installation requirements, tighten covers on both sides of the electronics housing.

⚠ CAUTION

Use caution when handling the Power Module. The Power Module may be damaged if dropped from heights in excess of 20 ft. (6 m).

This device complies with Part 15 of the FCC Rules. Operation is subject to the following conditions: This device may not cause harmful interference. This device must accept any interference received, including interference that may cause undesired operation. This device must be installed to ensure a minimum antenna separation distance of 20 cm (8 in.) from all persons.

4.3 Configuration procedure

Follow these steps for proper configuration:

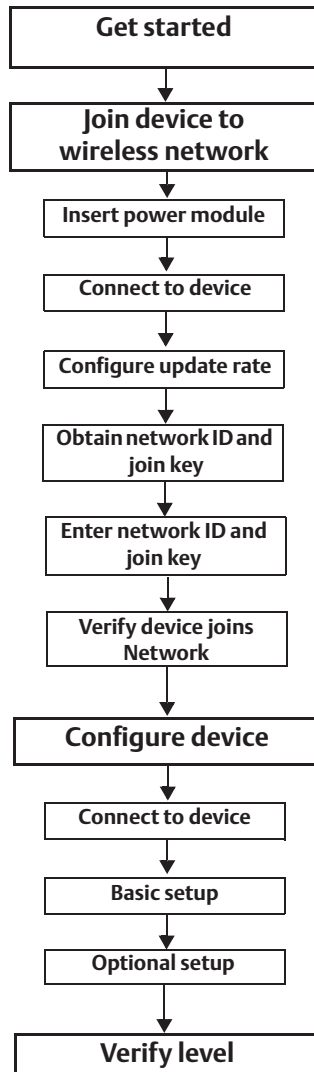

4.4 System readiness

4.4.1 Confirm correct device driver

Verify the latest Device Descriptor (DD) is loaded on your systems to ensure proper communication.

1. Within [Table 4-1](#), use the HART® Universal Revision and Device Revision numbers to find the correct DD.
2. Download the latest DD at EmersonProcess.com/DeviceFiles.

Table 4-1. Identification and Compatibility According to NAMUR NE 53

Release date	Device identification			DD identification		Review instructions	Review functionality
	NAMUR hardware revision ⁽¹⁾	NAMUR software revision ⁽¹⁾	HART software revision ⁽²⁾	HART universal revision	Device revision	Manual document number	Change description
December-15	1.0.xx	1.0.xx	2	7	1	00809-0100-4308	Extended length and added probe support
June-17	1.1.xx	1.1.xx	3	7	2		High accuracy output and Rosemount™ VeriCase support

1. NAMUR revision is located on the transmitter label. Differences in level 3 changes, signified above by xx, represent minor product changes as defined per NE53. Compatibility and functionality are preserved and product can be used interchangeably.
2. HART software revision can be read using a HART capable configuration tool (select **Overview** > **Device Information** > **Revisions**).

4.5 Get started with your preferred configuration tool

4.5.1 AMS Wireless Configurator (version 12.0 or later is required)

The AMS Wireless Configurator is the recommended software tool for the wireless network devices, and is supplied with the Emerson Wireless Gateway. Refer to the AMS Wireless Configurator [Manual Supplement](#) for further information.

Configuration can be done by connecting to the wireless network devices either point-to-point using a HART modem as shown in [Figure 4-1](#), or wirelessly through the Gateway as shown in [Figure 4-2](#). Initial configuration to join a device to the wireless network must be done point-to-point.

Figure 4-1. Connect Point-to-Point using HART Modem

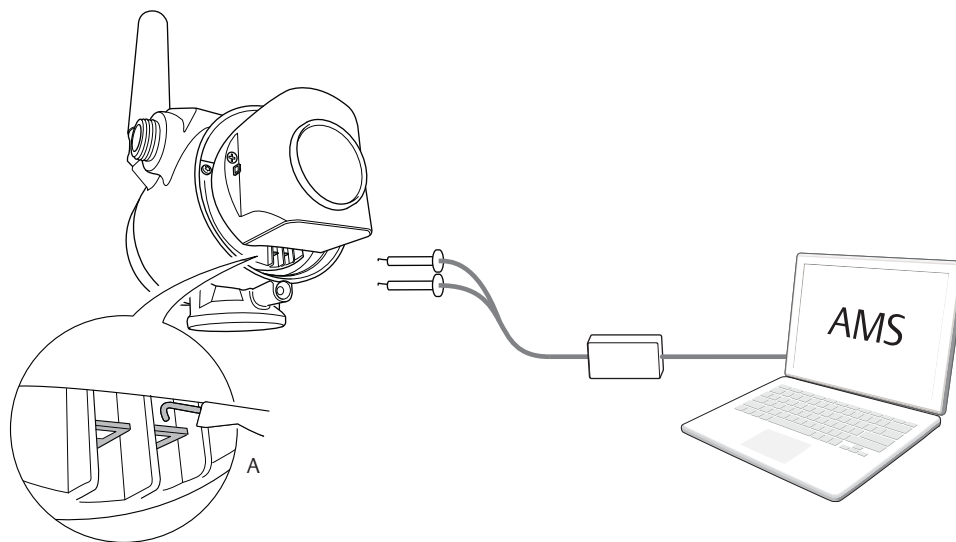

A. Communication terminals

Figure 4-2. Connect Wirelessly through the Wireless Gateway

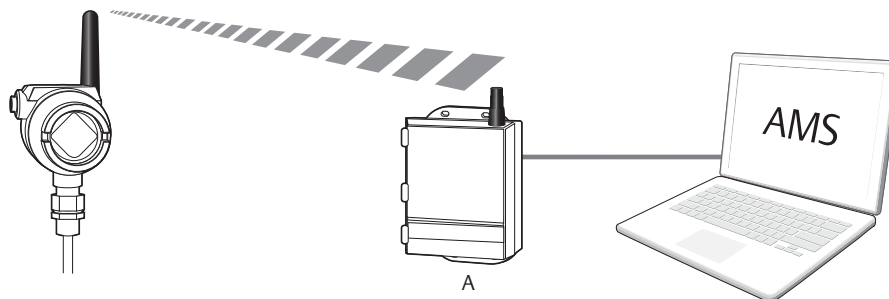

A. Wireless Gateway

Get the latest Device Descriptor (DD)

The Device Descriptor (DD) is a configuration tool that is developed to assist the user through the configuration.

The Rosemount 3308 Series DD is typically installed together with AMS Wireless Configurator. To download the latest HART DD, visit the Emerson™ Device Install Kit site at: EmersonProcess.com/Devicefiles

After downloading, add the DD to AMS Wireless Configurator:

1. Close **AMS Wireless Configurator**.
2. Go to **Start > Programs > AMS Device Manager** and select **Add Device Type**.
3. Browse to the downloaded DD files and select **Ok**.

In the *Add Device Type* application, select the **Help** button for more information on how to complete this operation.

Configure the HART modem interface

Before connecting to the device using a HART modem, the HART modem interface must be configured in AMS Wireless Configurator:

1. Close **AMS Wireless Configurator**.
2. Go to **Start > Programs > AMS Device Manager** and select **Network Configuration**.
3. Select **Add**.
4. In the drop down list, select **HART modem** and then select **Install**.
5. Follow the on-screen instructions.

In the *Network Configuration* application, select the **Help** button for more information on how to complete this operation.

Configure the wireless network interface

Before connecting to the device wirelessly using a Wireless Gateway, the wireless network must be configured in AMS Wireless Configurator:

1. Close AMS Wireless Configurator.
2. Go to **Start > Programs > AMS Device Manager** and select **Network Configuration**.
3. Select **Add**.
4. In the drop down list select **Wireless Network** and then select **Install**.
5. Follow the on-screen instructions.

In the *Network Configuration* application, select the **Help** button for more information on how to complete this operation.

4.5.2 Field Communicator

This section describes how to prepare the Field Communicator to communicate with a Rosemount 3308 Series Transmitter. The Field Communicator can be used to configure the device with a point-to-point connection. Connect the leads on the Field Communicator to the communication terminals of the device as shown in [Figure 4-3](#).

Figure 4-3. Connect Point-to-Point using a Field Communicator

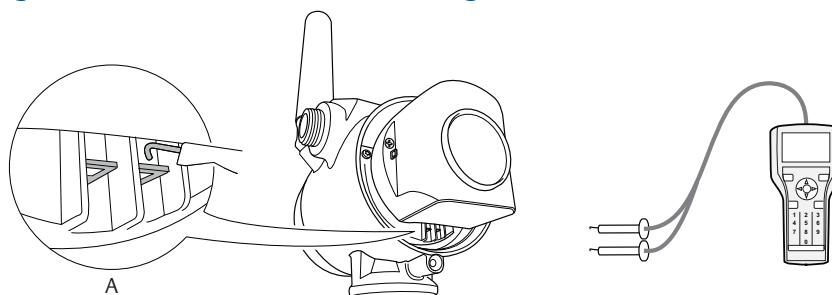

A. Communication terminals

Get the latest Device Descriptor (DD)

If the DD is not installed in your Field Communicator, see the appropriate Field Communicator User's Manual available at Emerson.com/FieldCommunicator for instructions on how to update the Field Communicator with the latest DD.

4.6 Join device to wireless network

4.6.1 Power up the wireless device

Make sure that the Wireless Gateway is installed and functioning properly before any wireless field devices are powered. See “Install the power module” on page 55 for further information on how to install the power module.

Wireless devices should be powered up in order of proximity from the Gateway, beginning with the closest. This will result in a simpler and faster network installation.

Enable Active Advertising on the Gateway to ensure that new devices join the network faster. For more information, see the Gateway [Reference Manual](#).

Startup screen sequence

The following screens will be displayed in sequence when the power module is first connected to the Rosemount 3308 Series Transmitter.

Figure 4-4. Startup Screen Sequence

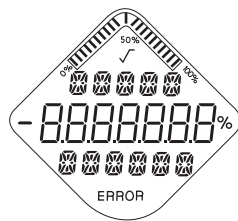

1. All Segments ON

Used to visually determine if there are any bad segments on the device display.

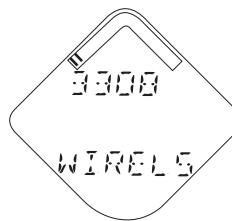

2. Device Identification

Identification string used to determine the Device Type.

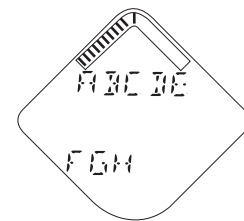

3. Device Information: Tag

User entered tag, 8 characters long. This screen will not display if all characters are blank.

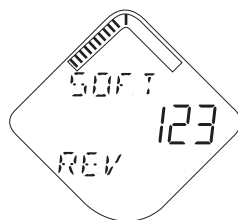

4. Software Revision

Used to determine Device Software Revision.

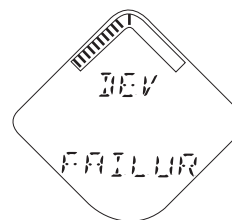

5. Device Information: Status

This screen will only appear if there is a critical error which may prevent the device from operating correctly. Check additional status screens for more information about failure source, refer to “Diagnostic button screen sequence” on page 78.



6. Primary Variable

Measurement value of mapped Primary Variable.



7. Secondary Variable

Measurement value of mapped Second Variable.



8. Electronics Temperature

Temperature value of device electronics.

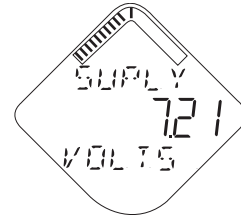

9. Supply Voltage

Voltage reading of the Power Module.

> 6 V	Good
5.2 V – 6.0 V	Low
< 5.2 V	Very low

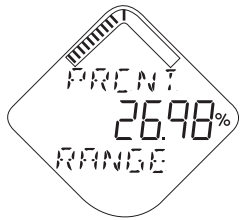

10. Percent of Range

Level value in percent of total measurement range.

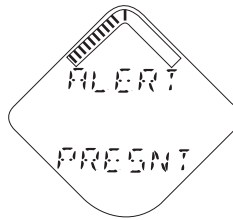

11. Active Alert Present

This screen will only appear if there is at least one Active Alert present. For detailed information of the failure source and recommended actions, go to the *Active Alerts* screen in AMS Wireless Configurator or Field Communicator. Refer to [“Check device status” on page 81](#). Some Active Alerts will be displayed on the LCD display as part of the diagnostic button screen sequence, refer to [“Diagnostic button screen sequence” on page 78](#).

4.6.2 Connect to device

Connect a Field Communicator or a HART modem to the communication terminals as shown in Figure 4-5.

Figure 4-5. Connect to Device

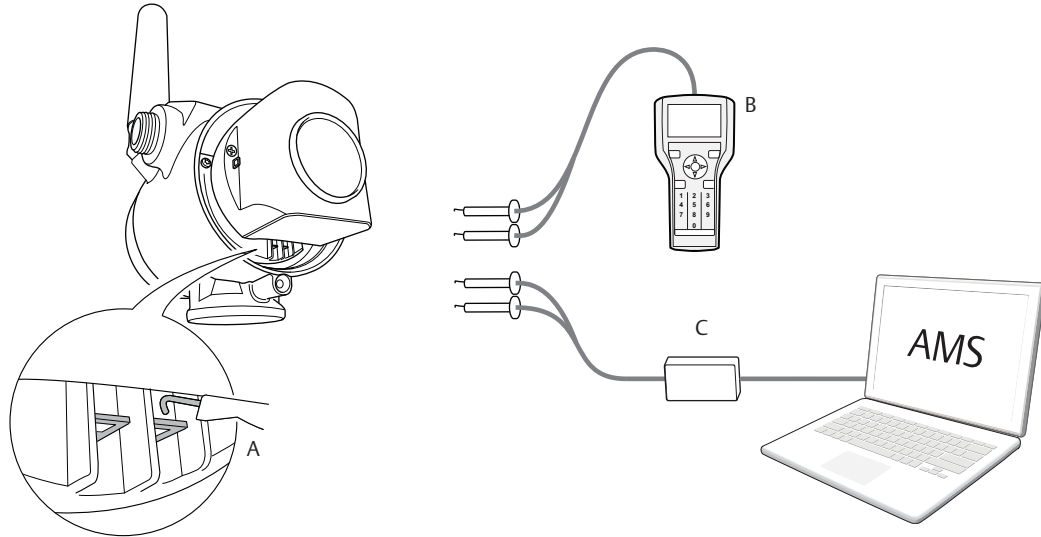

- A. Communication terminals
- B. Field Communicator
- C. HART Modem

AMS Wireless Configurator:

- a. Start AMS Wireless Configurator.
- b. Select **View > Device Connection View**.
- c. Double click the device under the HART modem.

Field Communicator:

- Turn on the Field Communicator and connect to the device.

For more information on how to connect to device refer to [“Get started with your preferred configuration tool”](#) on page 61.

4.6.3 Configure update rate

The Update Rate is the frequency at which a new measurement is transmitted over the wireless network. The default update rate is 1 minute. This may be changed at commissioning, or at any time via AMS Wireless Configurator or a Field Communicator. The Update Rate is user selectable from 4 seconds to 60 minutes.

1. Select **Configure > Guided Setup > Wireless Setup**.
2. Select **Configure Update Rate**, and follow the instructions.

Note

Make sure to set the Update Rate so that there is enough safety margin in the system for high/low alerts. If the time between each update is too long, the high/low alerts may be triggered too late.

Run Check Level Response to make sure that configured Update Rate is sufficient for the application, refer to section “Optional setup” on page 73.

4.6.4 Obtain network ID and join key

In order to communicate with the Wireless Gateway, and ultimately the host system, the transmitter must be configured to communicate on the wireless network. This step is the wireless equivalent of connecting wires from a transmitter to the host system.

The Network ID and Join Key may be obtained from the Wireless Gateway's integrated web interface on the **Setup > Network > Settings** page, as shown in Figure 4-6.

Figure 4-6. Gateway Network Settings



4.6.5 Enter network ID and join key

The devices must be configured with the same Network ID and Join Key as the Gateway in order to join the network. Use a Field Communicator or AMS Wireless Configurator to enter the **Network ID** and **Join Key** so they match the Network ID and Join Key of the Gateway.

1. Select **Configure > Guided Setup > Wireless Setup**.
2. Select **Join Device to Network**, and follow the instructions.

If the device is not to be commissioned yet, remove the power module and fasten the housing cover. This is to conserve power module life and to ensure safe transmitter transportation. The power module should be inserted only when the device is ready to be commissioned.

4.6.6 Verify device joins network

Network connection can be verified in four ways, further described in this section:

1. At the device display
2. Using the AMS Wireless Configurator
3. In the Wireless Gateway's integrated web interface
4. Using the Field Communicator

If the Rosemount 3308 Series was configured with the Network ID and Join Key, and sufficient time has passed, the transmitter should be connected to the network. It usually takes a few minutes for the device to join the network. If the device has not joined the network, please see [“Wireless network troubleshooting” on page 92](#).

Verify by device display

To verify that the device is connected to the network by the display, press the **DIAG** button. The display will show: the Tag, Device Serial Number, Software Revision, Network ID, Network Connection Status, and Device Status screens. Refer to [“Diagnostic button screen sequence” on page 78](#).

When the network diagnostic status is displayed as “NETWK OK”, the device has successfully joined the network. When joining the wireless network, the status displayed will be changed through the sequence until the device finally has joined the network. [Figure 4-7 on page 69](#) presents the different network connection status screens.

Figure 4-7. Network Connection Status Screens

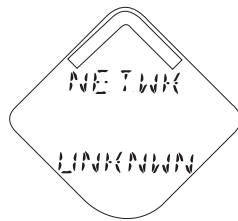
**Network Unknown**

The device is still in the process of being activated.

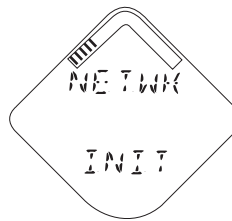
**Network Restarted**

The device has just restarted.

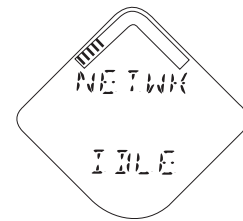
**Network Idle**

The device is starting to join the process.

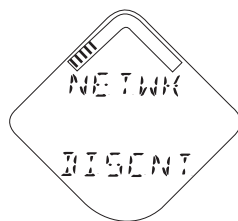
**Disconnected from Network**

The device is in a disconnected state and requires a “Force Join” command to join the network.

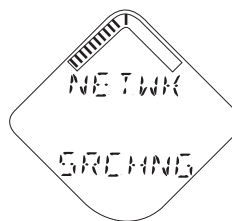
**Searching for Network**

The device is searching for the network.

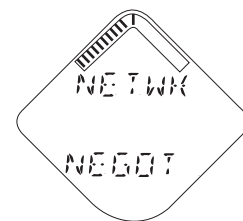
**Joining the Network**

The device is attempting to join the network.

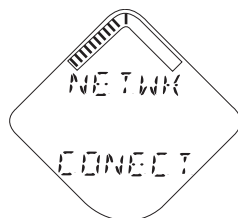
**Connected but in a “quarantined” state**

The device is connected to the network, but is in a “quarantined” state.

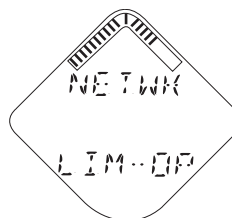
**Connected with Limited Bandwidth**

The device is joined and operational, but is running with limited bandwidth for sending periodic data.

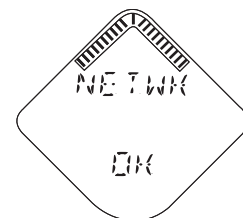
**Connected**

The device has successfully joined the network.

Verify with AMS Wireless Configurator

Start the AMS Wireless Configurator. When the device has joined the network, it will appear in the AMS Wireless Configurator window as illustrated in Figure 4-8.

Figure 4-8. AMS Wireless Configurator Screen

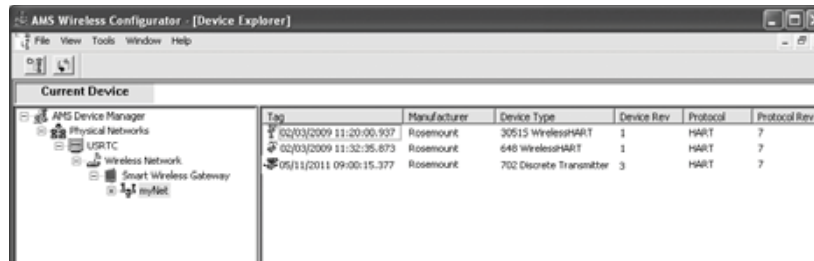

Figure 4-9 presents the different network connection status images that are shown in the AMS Wireless Configurator Overview screen.

Figure 4-9. Network Connection Status Images



Verify by Gateway

To use the Wireless Gateway's integrated web interface, navigate to the **Explorer > Status** page as shown in [Figure 4-10](#). This page shows whether the device has joined the network and if it is communicating properly.

Locate the device in question and verify all status indicators are good (green). It may take several minutes for the device to join the network and be seen on the Gateway's integrated web interface.

Figure 4-10. Wireless Gateway Explorer Status Page

UART Tag	UART Status	Last update	PV	SW	TV	QV	Word (Hz)
UART0	●	34/02/11 10:00:05	0.000	1,344.400 Hz	23.000 DegC	7.302 v	0
RS485-Processor	●	34/02/11 10:00:05	<0.027 Amplitude	20.700 DegC	20.700 DegC	7.111 v	0
RS485-Connectivity	●	34/02/11 10:00:05	0.700 psi	15.000 DegC		7.281 v	18
RS485-RTN	●	34/02/11 10:00:05	0.000 psi	22.000 DegC	-168.000 mV	7.287 v	18
RS485-Temperature	●	34/02/11 10:00:05	23.000 DegC	NaN DegC	23.000 DegC	7.111 v	0
RS485-Position	●	34/02/11 10:00:05	1.000 m	0.000	0.000	23.000 DegC	0
RS485-Current	●	34/02/11 10:00:05	1.000	0.000	23.000 DegC	7.302 v	0
RS485-Temperature	●	34/02/11 10:00:05	23.000 DegC	22.000 DegC	23.000 DegC	24.961 DegC	00
RS485-Location	●	34/02/11 17:20:02	0.000 psi	0.000 psi	2.301 v	7.243 v	01:00:00
RS485-Temperature	●	34/02/11 10:00:05	23.000 DegC	NaN DegC	23.000 DegC	7.111 v	18
RS485-Position	●	34/02/11 10:00:05	4.000 Counts	24.000 DegC	20.000 DegC	2.301 v	18

Verify with Field Communicator

Connect the Field Communicator as shown in [Figure 4-5](#) on [page 66](#). Do not remove the power module. Removing the power module may cause the device to drop off the network.

Note

In order to communicate with a Field Communicator, the device must be powered by the power module.

To verify the device has joined the network:

1. Select **Service Tools > Communications**.
2. Select **Join Status**.

4.7 Configure device using guided setup

4.7.1 Connect to device

Connect to the device using your preferred configuration tool, as shown in [Figure 4-11](#) and [Figure 4-12](#).

AMS Wireless Configurator:

- Start AMS Wireless Configurator.
- Select **View > Device Connection View**.
- Double click the device under the HART modem.

Field Communicator:

- Turn on the Field Communicator and connect to the device.

Figure 4-11. Connect to Device - Point-to-Point

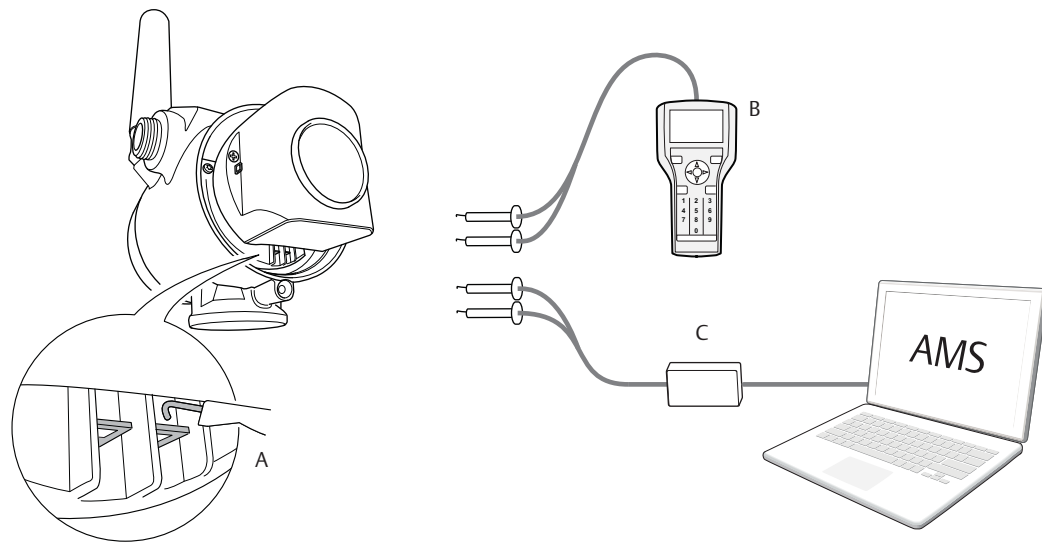

- A. Communication terminals
B. Field Communicator

C. HART Modem

Figure 4-12. Connect to Device - Wirelessly

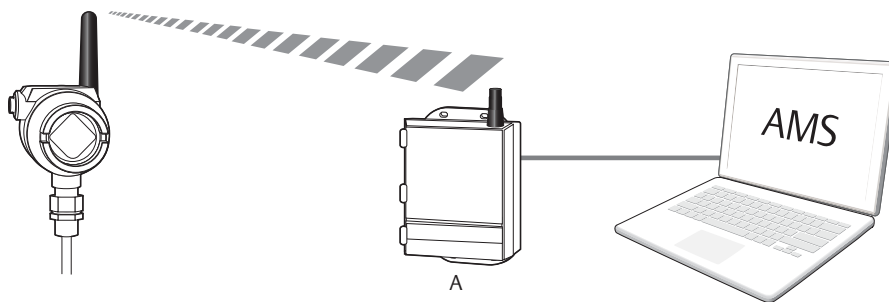

- A. Wireless Gateway

4.7.2 Basic setup

All Basic Setup parameters are described in the section “Configuration parameters” on page 161.

Figure 4-13. Guided Setup Screen

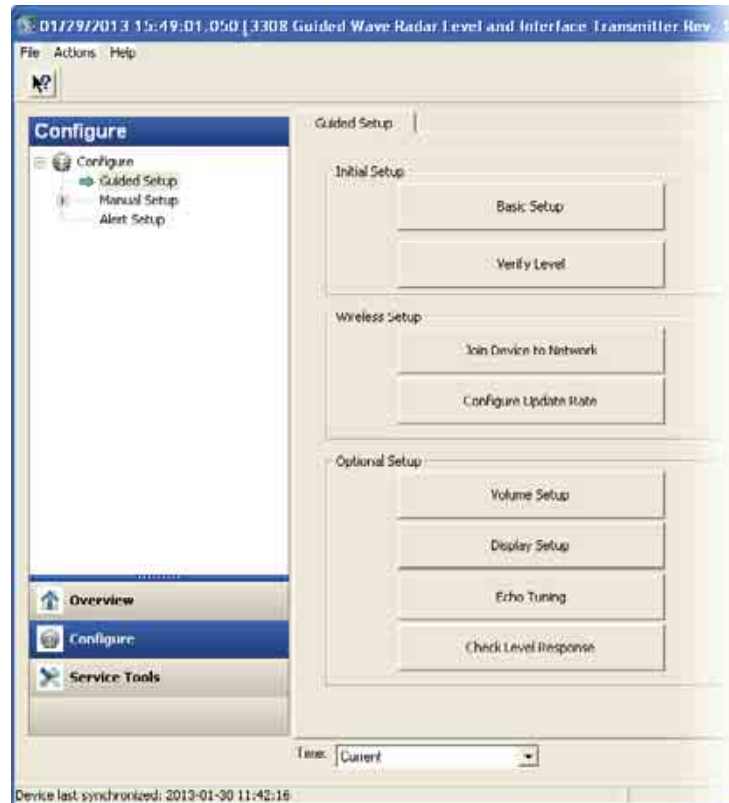

1. Select **Configure**.
2. Select **Guided Setup > Initial Setup**.
3. Select **Basic Setup**, and follow the instructions.

4.7.3 Optional setup

Consider Optional Setup such as Volume, Device Display, Echo Tuning, and Check Level Response, found in the Guided Setup. Run Check Level Response to review the maximum level change between updates with the current configuration.

1. Select **Configure**.
2. Select **Guided Setup > Optional Setup**.
3. Select the desired Optional Setup, and follow the instructions.

Additional configuration parameters are available in the Manual Setup menu. For further information about the parameters see “Configuration parameters” on page 161.

4.8 Verify level

Run the Verify Level tool to match the product level reported by the device to a reference measurement (measured by using for example handgauging). If any difference, the Calibration Offset parameter will be adjusted as shown in Figure 4-14.

A minor adjustment using Calibration Offset is normal. There may, for example be a deviation between the actual tank height and the configured value.

Non-metallic (e.g. plastic) vessels and installation geometry may introduce an offset for the Upper Reference Point. This offset may be up to ± 2 in. (50 mm). The offset can be compensated for using Calibration Offset.

Note

Before running Verify Level, make sure the product surface is calm, the tank is not being filled or emptied, and the actual level is well above the probe end.

To run Verify Level:

1. Select **Configure**.
2. Select **Guided Setup > Initial Setup**.
3. Select **Verify Level** to check your level measurement, and follow the instructions.

Figure 4-14. Calibration Offset

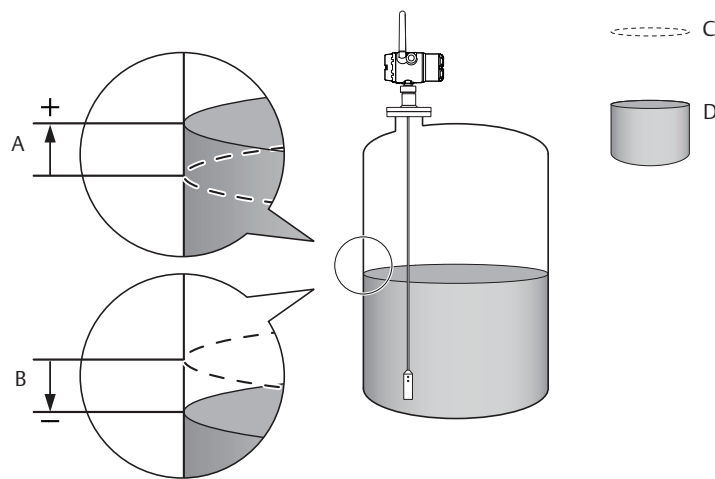

- A. Positive Calibration Offset value
- B. Negative Calibration Offset value
- C. Reported level
- D. Actual level

Section 5 Operation

Safety messages	page 75
Device display screen messages	page 77
View measurement values	page 80
Check device status	page 81

5.1 Safety messages

Instructions and procedures in this section may require special precautions to ensure the safety of the personnel performing the operations. Information that potentially raises safety issues is indicated by a warning symbol (⚠). Refer to the following safety messages before performing an operation preceded by this symbol.

⚠ WARNING

Explosions could result in death or serious injury.

- Verify that the operating environment of the gauge is consistent with the appropriate hazardous locations certifications.
- Installation of device in an explosive environment must be in accordance with appropriate local, national and international standards, codes, and practices.
- Ensure device is installed in accordance with intrinsically safe or non-incendive field practices.

Electrical shock can result in death or serious injury.

- Ground device on non-metallic tanks (e.g. fiberglass tanks) to prevent electrostatic charge build-up.
- Single lead probes are sensitive for strong electromagnetic fields and therefore not suitable for non-metallic tanks.
- Care must be taken during transportation of power module to prevent electrostatic charge build-up.
- Device must be installed to ensure a minimum antenna separation distance of 8 in. (20 cm) from all persons.

Process leaks could result in death or serious injury.

- Handle the transmitter carefully.
- If the process seal is damaged, gas could escape from the tank when removing the transmitter head from the probe.
- Only qualified personnel should install the equipment.
- Do not remove the transmitter while in operation.

⚠ WARNING

To ensure long life for your radar transmitter, and to comply with hazardous location installation requirements, tighten covers on both sides of the electronics housing.

⚠ CAUTION

This device complies with Part 15 of the FCC Rules. Operation is subject to the following conditions: This device may not cause harmful interference. This device must accept any interference received, including interference that may cause undesired operation. This device must be installed to ensure a minimum antenna separation distance of 20 cm (8 in.) from all persons.

5.2 Device display screen messages

The device display can be used to present different variables and a diagnostic screen sequence.

5.2.1 Variable screens

If the Display Mode is set to Periodic, the device display shows a periodic sequence of user-chosen variables during operation. A new screen appears according to configured wireless update rate. The device display will also show ALERT PRESENT if at least one alert is present. For information on how to configure the device display, see “Device display” on page 165.

The Rosemount™ 3308 Series Transmitter can display the following variables:

Figure 5-1. LCD Display Variables

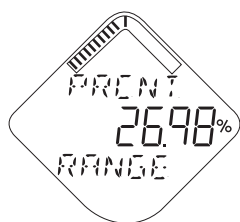

Percent of Range

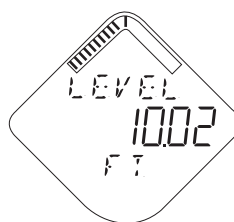

Level

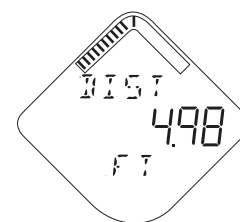

Distance

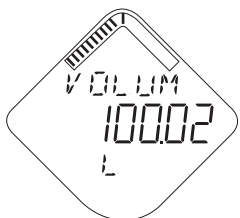

Total Volume

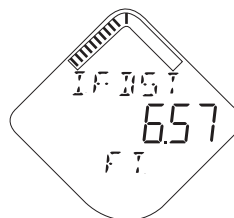

Interface Distance

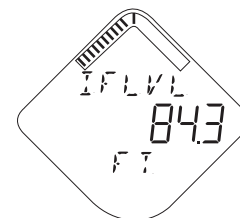

Interface Level

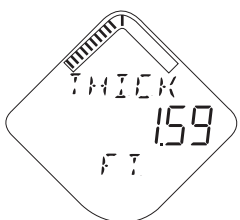

Upper Product Thickness



Electronics Temperature

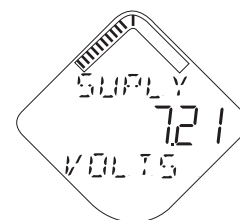

Supply Voltage



Signal Quality

5.2.2 Diagnostic button screen sequence

The diagnostic button screen sequence on the device display can be used to obtain detailed diagnostic information.

1. Unscrew the device display cover.

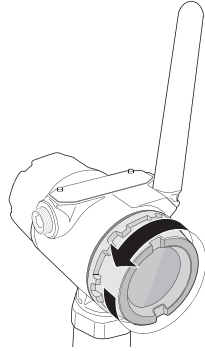

2. Press and hold the **DIAG** button until the first diagnostic button screen appears on the device display. Release the **DIAG** button.

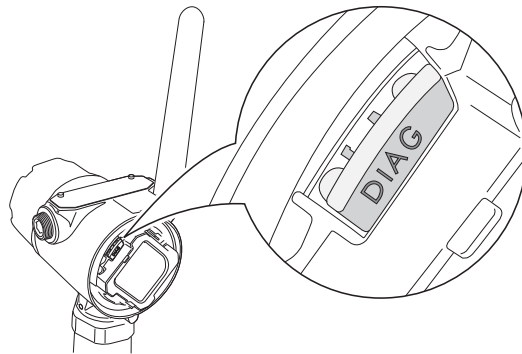

The device display will now automatically show the diagnostic screens as illustrated in [Figure 5-2](#).

Figure 5-2. Diagnostic Button Screen Sequence

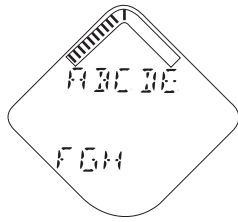

1. Device Information: Tag

User entered tag which is 8 characters long. This screen will not display if all characters are blank.

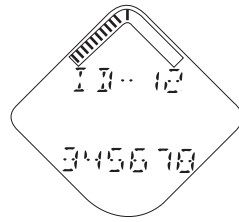

2. Device Serial Number

Used to determine Device Serial Number.

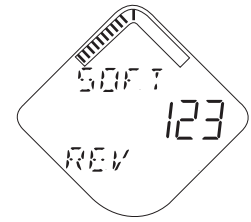

3. Software Revision

Used to determine Device Software Revision.

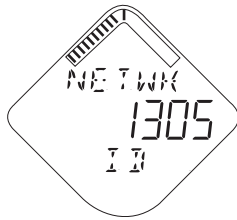

4. Network ID

Used to determine the entered Network ID in the device.

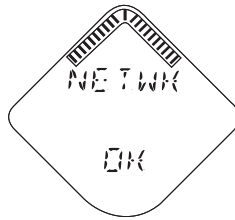

5. Network Connection Status

The screen displayed is dependent on the progress of the device in joining the wireless network. See [Figure 4-7 on page 69](#) for more information.

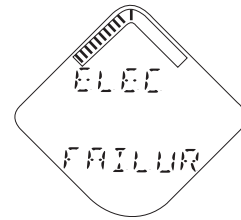

6. Active Alert Screens (if present)

See [“Device display alerts” on page 84](#) for a full list of Active Alerts that may appear on this position of the sequence.



7. Variable Screens

At the end of the sequence, the device display shows all selected variable screens.

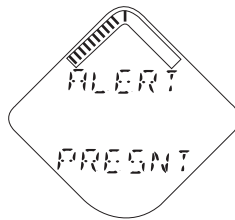

8. Active Alert Present

This screen will only appear if there is at least one Active Alert present. For detailed information of the failure source and recommended actions, go to the *Active Alerts* screen in AMS Wireless Configurator or Field Communicator. Refer to [“Check device status” on page 81](#).

5.3 View measurement values

Measurement values can be viewed using AMS Wireless Configurator and Field Communicator.

5.3.1 View current measurement values

Current measurement data of the Primary Variable (PV) and Secondary Variable (SV) are presented on the *Overview* screen. To view all current measurement values:

1. Select **Service Tools > Variables**.
2. Select the desired group of measurement values to view.
 - To view gauges for the Primary Variable (PV), Secondary Variable (SV), Third Variable (TV) and Fourth variable (QV), select **Mapped Variables**.
 - To view process values such as Level, Distance, Percent of Range, select **Process**.
 - To view device values such as Electronics Temperature, Supply Voltage, select **Device**.
 - To view Signal Quality, select **Signal Quality**.

5.3.2 View trends

1. Select **Service Tools > Trends**.
2. Select to log measurement values either in a graph or a table.
 - To log Level and Interface Level values in a graph, select **Level**.
 - To log Distance values in a graph, select **Distance**.
 - To log Total Volume in a graph, select **Volume**.
 - To log Signal Quality in a graph, select **Signal Quality**.
 - To log the trend of 12 data points shown in a table, select **Data History**, and then select **View Data History**. See “[Configure data history](#)” on page 166 for information on how to configure device variable for recording and time between samples.

Note

Values are logged in the trend graphs only as long as the **Trends** item is selected.

5.3.3 Interpret measurement status bars

A “Good” or “Bad” status next to a value is an indication of the reliability or integrity of the data being received, not an indication of whether or not the value is within the configured upper or lower ranges. A value that triggers an alert, such as a high or low temperature indication, will change the overall status of the device, but the measurement might still be indicated as “Good” if the reliability of the data is good.

Figure 5-3. Measurement Status Bars





5.4 Check device status

The overall device status is presented in AMS Wireless Configurator and Field Communicator under the **Overview** screen. The Rosemount 3308 Series reports diagnostic alerts when there is a device malfunction. For information on these alerts, see “Alert messages in AMS Wireless Configurator and Field Communicator” on page 86. The device can also be configured to report user defined alerts based on the measured variables, see “Alert setup” on page 172 for more information.

To check device status and see whether there are any Active Alerts reported, do one of the following:

- The overall device status is presented in the *Overview* screen. If status is anything than *Good*, select the button in the device status image to open a window with Active Alerts. The different device status images can be found in Table 5-1.
- Active Alerts can also be obtained via **Service Tools > Alerts > Active Alerts**.

Table 5-1. Presentation of Device Status Images

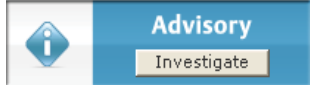
Device status image	Condition
Device: 	<i>Good</i> : No active alert.
Device: 	<i>Failed</i> : At least one Failure Alert is active. Click the Troubleshoot button to open a window with Active Alerts together with recommended actions.
Device: 	<i>Maintenance</i> : At least one Maintenance Alert is active (and no Failed alerts). Click the Investigate button to open a window with Active Alerts together with recommended actions.
Device: 	<i>Advisory</i> : At least one Advisory Alert is active (and no Failed or Maintenance Alerts). Click the Investigate button to open a window with Active Alerts together with recommended actions.

Section 6 Service and Troubleshooting

Safety messages	page 83
Alert messages	page 84
Troubleshooting guide	page 90
Service and troubleshooting tools	page 93
Application challenges	page 100
Power module replacement	page 106
Transmitter head replacement	page 108
Probe replacement	page 109
Service support	page 110

6.1 Safety messages

Procedures and instructions in this section may require special precautions to ensure the safety of the personnel performing the operations. Information that raises potential safety issues is indicated by a warning symbol (⚠). Refer to the following safety messages before performing an operation preceded by this symbol.

⚠ WARNING

Failure to follow safe installation and servicing guidelines could result in death or serious injury.

- Make sure the transmitter is installed by qualified personnel and in accordance with applicable code of practice.
- Use the equipment only as specified in this manual. Failure to do so may impair the protection provided by the equipment.

Electrical shock can result in death or serious injury.

- Ground device on non-metallic tanks (e.g. fiberglass tanks) to prevent electrostatic charge build-up.
- Single lead probes are sensitive for strong electromagnetic fields and therefore not suitable for non-metallic tanks.
- Care must be taken during transportation of power module to prevent electrostatic charge build-up.
- Device must be installed to ensure a minimum antenna separation distance of 8 in. (20 cm) from all persons.
- Probes covered with plastic and/or with plastic discs may generate an ignition-capable level of electrostatic charge under certain extreme conditions. Therefore, when the probe is used in a potentially explosive atmosphere, appropriate measures must be taken to prevent electrostatic discharge.

⚠ WARNING**Explosions could result in death or serious injury.**

- Verify the operating environment of the gauge is consistent with the appropriate hazardous locations certifications.
- Installation of device in an explosive environment must be in accordance with appropriate local, national and international standards, codes, and practices.
- Ensure device is installed in accordance with intrinsically safe or non-incendive field practices.

Process leaks could result in death or serious injury.

- Only qualified personnel should install the equipment.
- Install transmitter prior to process start-up.
- Install and tighten process connectors before applying pressure.
- Handle the transmitter carefully.
- Do not remove the transmitter while in operation.
- If the process seal is damaged, gas could escape from the tank when removing the transmitter head from the probe.

⚠ WARNING

To ensure long life for your radar transmitter, and to comply with hazardous location installation requirements, tighten covers on both sides of the electronics housing.

Any substitution of non-recognized parts may jeopardize safety. Repair, e.g. substitution of components etc., may also jeopardize safety and is under no circumstances allowed.

⚠ CAUTION

Use caution when handling the Power Module. The Power Module may be damaged if dropped from heights in excess of 20 ft. (6 m).

This device complies with Part 15 of the FCC Rules. Operation is subject to the following conditions: This device may not cause harmful interference. This device must accept any interference received, including interference that may cause undesired operation. This device must be installed to ensure a minimum antenna separation distance of 20 cm (8 in.) from all persons.

6.2 Alert messages

6.2.1 Device display alerts

The following active alert screens will show the device diagnostics depending on the state of the device.

If the device display shows ALERT PRESNT but none of the following screens appear, then go to the *Active Alerts* screen in AMS Wireless Configurator or Field Communicator for further information.

For detailed information of the failure source and recommended actions, go to the *Active Alerts* screen in AMS Wireless Configurator or Field Communicator, see “[Alert messages in AMS Wireless Configurator and Field Communicator](#)” on page 86.

Figure 6-1. Active Alerts Screens

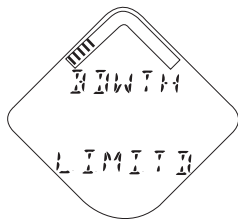

Bandwidth Limited

The device has not yet received all of the requested wireless bandwidth needed to operate as configured. See [“Wireless network troubleshooting”](#) on page 92 for recommended actions.

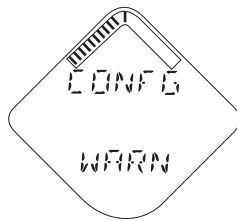

Configuration Warning

The device has detected a configuration error. Non-critical operation of the device may be affected.

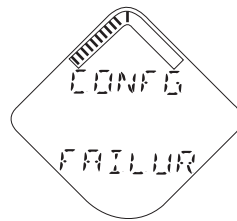

Configuration Failure

The device has detected a configuration error. Critical operation of the device may be affected.

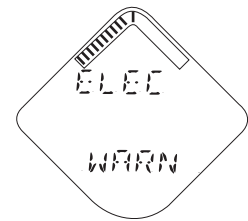

Electronics Warning

There is a warning which should be addressed but should not affect the device output.

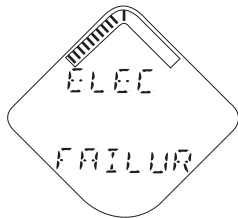

Electronics Failure

An electronics error that could impact the device measurement reading has occurred.

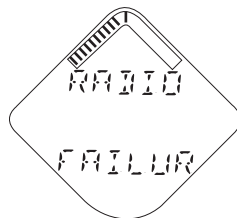

Radio Failure

The wireless radio has detected a failure or stopped communicating.

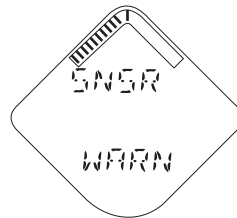

Sensor Warning

A sensor attached to the transmitter is degraded. Readings from that sensor may not be within accuracy specifications.

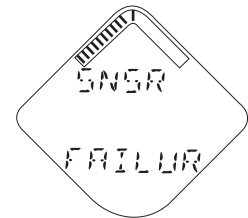

Sensor Failure

A sensor attached to the transmitter has failed, and valid readings from that sensor are no longer possible.

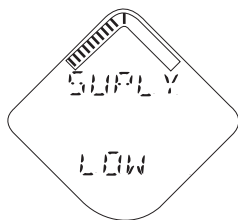

Supply Voltage Low

The voltage is below the recommended operating range. Replace the Power Module, see [“Power module replacement”](#) on page 106.

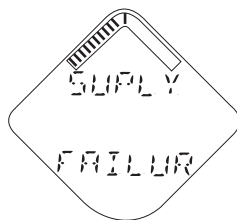

Supply Voltage Failure

The supply voltage is too low and will affect device operation. Replace the Power Module, see [“Power module replacement”](#) on page 106.

6.2.2 Alert messages in AMS Wireless Configurator and Field Communicator

Table 6-1 to Table 6-4 shows list of alert messages that may be displayed in the AMS Wireless Configurator and Field Communicator.

To view Active Alerts, select **Service Tools > Alerts > Active Alerts**.

Table 6-1. Failure Alerts (F:)

Message	Description	Recommended actions
Electronics Failure	An electronics error that could impact the device measurement reading has occurred.	<ol style="list-style-type: none"> 1. Restart the device. 2. Restore the default settings and reconfigure device. 3. If the condition persists, replace the device.
Radio Failure	The wireless radio has detected a failure or stopped communicating.	<ol style="list-style-type: none"> 1. Restart the device. 2. If the condition persists, replace the device.
Critical Power Failure	The supply voltage is too low and will affect Device Operation.	<ol style="list-style-type: none"> 1. Replace the Power Module, see “Power module replacement” on page 106.
Probe Disconnected	The device cannot detect the probe.	<ol style="list-style-type: none"> 1. Check that the probe connection is properly tightened. 2. Check that the probe connection is dry and clean. 3. Restart level measurements. 4. If the condition persists, replace the device and/or the probe.
Electronics Temperature Critical	The internal temperature of the device has reached critical levels and the integrity of the device electronics may be compromised. Environmental temperature should not exceed device specifications.	<ol style="list-style-type: none"> 1. Verify that ambient temperature is within the specified range. For more information about the maximum ambient temperature, see “Temperature limits” on page 117. 2. Remote mount the transmitter head away from the process and environmental conditions. 3. Restart the device. 4. If the condition persists, replace the device.
Remote Housing Error	The device has detected a problem associated with the remote housing.	<ol style="list-style-type: none"> 1. Correct remote housing configuration to match connected remote housing cable. 2. Check remote housing cable.
Configuration Error	The device has detected a configuration error. Reasons may be multiple. See Table 6-2 for a list of detailed Configuration Errors that may be displayed.	<ol style="list-style-type: none"> 1. Click on the Details button for more information. 2. Correct the parameter causing the configuration error.

Table 6-2. Configuration Error Details (D:)

Message	Description	Recommended actions
Lower Range Value or Upper Range Value is out of limits	The lower/upper range value is outside the lower/upper sensor limits. This is outside the range where the sensor works properly, hence the measurement may be unreliable.	1. Check the lower and upper range values in relation to the sensor limits.
Configured Measurement Mode not Supported	The configured Measurement Mode does not work since support has not been purchased.	1. Upgrade the device. 2. Change the Measurement Mode to match, refer to “Measurement mode” on page 163.
Volume Configuration Error	The volume cannot be calculated correctly with the current configuration.	1. Check that the level-volume values in the strapping table are entered in increasing order, refer to “Strapping table” on page 171. 2. Check that the number of strapping points to use is correct. 3. Check size measures in the Volume Setup.
Unsupported Probe and Nozzle Configuration	Rigid Single Lead 0.5 in / 13 mm probe is configured in combination with 1.5 inch Nozzle. This combination is invalid and results in unreliable measurement.	1. Install a nozzle with a supported inner diameter and re-configure transmitter.
Parameter Out of Limits	One or more of the configuration values, in a set that belongs together, has been changed and reduced the measurement range of the device.	1. Check the configured values for Probe Length, Vapor Dielectric Constant, and Upper Product Dielectric Constant. 2. Restore default settings and reconfigure the device.
Low Low Level Alert configuration is invalid	Low Low Level Alerts will not be raised as expected because of invalid configuration.	1. Check entered limit and deadband values in comparison with entered tank and probe parameters such as probe length, tank height etc.
Low Level Alert configuration is invalid	Low Level Alerts will not be raised as expected because of invalid configuration.	1. Check entered limit and deadband values in comparison with entered tank and probe parameters such as probe length, tank height etc.
High Level Alert configuration is invalid	High Level Alerts will not be raised as expected because of invalid configuration.	1. Check entered limit and deadband values in comparison with entered tank and probe parameters such as probe length, tank height etc.
High High Level Alert configuration is invalid	High High Level Alerts will not be raised as expected because of invalid configuration.	1. Check entered limit and deadband values in comparison with entered tank and probe parameters such as probe length, tank height etc.
User Defined Alert configuration is invalid	User Defined Alerts will not be raised as expected because of invalid configuration.	1. Check entered limit and deadband values in relation to the selected variable.
Signal Quality Alert configuration is invalid	Signal Quality Alerts will not be raised as expected because of invalid configuration.	1. Check entered limit and deadband values regarding their range [0.1 – 10.0] and mutual relationship.
No user configuration errors detected	No user configuration errors detected.	

Table 6-3. Maintenance Alerts (M:)

Message	Description	Recommended actions
Supply Voltage Low	The supply voltage is low and may affect Device Operation.	1. Replace the Power Module, see “Power module replacement” on page 106.
Electronics Temperature Out of Limits	The temperature of the electronics board has exceeded the transmitter’s operating range.	<ol style="list-style-type: none"> 1. Verify that ambient temperature is within the operating range. 2. Restart the device. 3. Remote mount the transmitter head away from the process and environmental conditions. 4. If the condition persists, replace the device.
Level Measurement Lost	<p>No valid Level reading. Reasons may be multiple:</p> <ul style="list-style-type: none"> ■ No valid surface echo peak in the measuring range. ■ Incorrect transmitter configuration. 	<ol style="list-style-type: none"> 1. Analyze the Echo Curve for reason and check device configuration, especially thresholds, Near Zone, Maximum Level Rate and settings on the Lost Measurement tab in the Alert Setup. 2. Check device physical installation (for instance probe contamination). 3. Restart level measurement. 4. Restore default settings and reconfigure the device. 5. If the condition persists, replace the device.
Interface Measurement Lost	<p>No valid Interface reading. Reasons may be multiple:</p> <ul style="list-style-type: none"> ■ No valid surface echo peak in the measuring range. ■ Incorrect transmitter configuration. 	<ol style="list-style-type: none"> 1. Analyze the Echo Curve for reason and check device configuration, especially thresholds, false echoes, Near Zone, Maximum Level Rate and settings on the Lost Measurement tab in the Alert Setup. 2. Check device physical installation (for instance probe contamination). 3. Restart measurement. 4. Restore the default settings and reconfigure device. 5. If the condition persists, replace the device.
Low Signal Quality	The Signal Quality is below the defined alert limit.	<ol style="list-style-type: none"> 1. Take action based on your intended use of this alert. 2. Clean the probe. 3. If no actions were necessary, consider to change the limit.
Capacity Denied	The device has failed to acquire the wireless communication bandwidth necessary to support the configured update rates.	<ol style="list-style-type: none"> 1. Obtaining the bandwidth may take some time depending on the configured update rates and other devices in the network. Wait several minutes to see if the error resolves itself. 2. There may be too many devices attached to the WirelessHART® network, or the update rates may be too fast. Try using a different network, or slowing down the update rate on one or more devices.
PV Out of Limits	The primary measurement is outside the sensor limits and may be unreliable.	<ol style="list-style-type: none"> 1. Bring the system to a safe state. 2. Verify that the primary measurement is within specified limits. 3. Restart the device. 4. If the condition persists, replace the device.
Non-PV Out of Limits	One of the non-primary measurements is outside the associated sensor limits and may be unreliable.	<ol style="list-style-type: none"> 1. Bring the system to a safe state. 2. Verify that all non-primary measurements are within specified limits. 3. Restart the device. 4. If the condition persists, replace the device

Table 6-4. Advisory Alerts (A:)

Message	Description	Recommended actions
Database Memory Warning	The device has failed to write to the database memory at some time in the past. Any data written during this time may have been lost.	<ol style="list-style-type: none"> 1. If logging dynamic data is not needed, this advisory alert can be safely ignored. 2. Restart the device. 3. Reconfirm all configuration items in the device. 4. Restore default settings and reconfigure the device. 5. If the condition persists, replace the device.
Non-Critical User Data Warning	A user written parameter does not match expected value.	<ol style="list-style-type: none"> 1. Restart the device. 2. Reconfirm all configuration items in the device. 3. Restore default settings and reconfigure the device. 4. If the condition persists, replace the device.
Volume Range Warning	The level measurement is outside the configured volume range.	<ol style="list-style-type: none"> 1. Check volume configuration.
Verification Mode Active	The device is in verification mode and is not reporting actual information.	<ol style="list-style-type: none"> 1. If this behavior is not desired, stop verification mode.
Button Stuck	The button on the Electronics Board is detected as stuck in the active position.	<ol style="list-style-type: none"> 1. Check the buttons for obstructions. 2. If the condition persists, restart the device. 3. If the condition persists, replace the device.
HiHi Level Alert	The level is above the defined limit.	<ol style="list-style-type: none"> 1. Bring the system to a safe state. 2. Verify that the level is within specified limits. 3. Reconfirm the level alert limit. 4. If not needed, disable this alert.
Hi Level Alert	The level is above the defined limit.	<ol style="list-style-type: none"> 1. Bring the system to a safe state. 2. Verify that the level is within specified limits. 3. Reconfirm the level alert limit. 4. If not needed, disable this alert.
Lo Level Alert	The level is below the defined limit.	<ol style="list-style-type: none"> 1. Bring the system to a safe state. 2. Verify that the level is within specified limits. 3. Reconfirm the level alert limit. 4. If not needed, disable this alert.
LoLo Level Alert	The level is below the defined limit.	<ol style="list-style-type: none"> 1. Bring the system to a safe state. 2. Verify that the level is within specified limits. 3. Reconfirm the level alert limit. 4. If not needed, disable this alert.
User Defined Alert	The variable has surpassed the user defined limit.	<ol style="list-style-type: none"> 1. Bring the system to a safe state. 2. Verify that the process variable is within user specified limits. 3. Reconfirm the user defined alarm limit. 4. If not needed, disable this alert.
Simulation Active	The device is in simulation mode and is not reporting actual information.	<ol style="list-style-type: none"> 1. If this behavior is not desired, stop simulation mode. 2. If the condition persists, restart level measurements.

6.3 Troubleshooting guide

If there is a malfunction despite the absence of alerts, see [Table 6.3.1](#) for information on possible causes and recommended actions.

The troubleshooting guide contains the following symptoms:

- [Incorrect level readings](#), see [page 90](#).
- [Incorrect or missing interface level reading](#), see [page 91](#).
- [Power module troubleshooting](#), see [page 92](#).
- [Device display troubleshooting](#), see [page 92](#).
- [Wireless network troubleshooting](#), see [page 92](#).

6.3.1 Incorrect level readings

Symptom	Possible cause and recommended actions
The level readings do not correspond to a reference measurement, for example a handgauged value.	<ul style="list-style-type: none"> ■ Check the Tank Height parameter, refer to “Tank height” on page 162. ■ Check Thresholds, refer to “Adjusting thresholds” on page 94. ■ Run Verify Level, see “Verify level” on page 74. ■ Check transmitter configuration. Run Basic Setup, refer to “Basic setup” on page 73.
There is no level reading.	<ul style="list-style-type: none"> ■ The tank is empty. No action is needed. ■ Check Thresholds, refer to “Adjusting thresholds” on page 94.
Level spikes or level is suddenly reported as full or empty.	<ul style="list-style-type: none"> ■ Check the Upper Product Dielectric Constant, see “Upper product dielectric constant” on page 163. ■ The transmitter is configured with wrong Probe Type, refer to “Probe type” on page 162. ■ Check Thresholds, see “Adjusting thresholds” on page 94. ■ The transmitter has locked on disturbing obstacles at top of the tank. See “Handling disturbances at the top of the tank” on page 102 for recommended actions. ■ The surface is turbulent. Set the Performance Mode to High to get a stable measurement signal, refer to “Noise or weak surface echoes” on page 106.
Level stuck in full.	<ul style="list-style-type: none"> ■ The tank is full. Check the product level. ■ Check Thresholds, see “Adjusting thresholds” on page 94. ■ The transmitter has locked on disturbing obstacles at top of the tank. See “Handling disturbances at the top of the tank” on page 102 for recommended actions. ■ The transmitter is configured with wrong Probe Type, refer to “Probe type” on page 162. ■ The reference peak is not detected since it is weaker than the Reference Threshold. Adjust Reference Threshold to an appropriate value so that reference peak is not filtered out. Refer to “Adjusting thresholds” on page 94.

Symptom	Possible cause and recommended actions
Level stuck in measuring range.	<ul style="list-style-type: none"> ■ May be caused by a disturbing object in the tank. Read the Echo Curve and adjust Thresholds, see “Adjusting thresholds” on page 94. ■ Check if the probe is bent and in contact with the tank wall. This contact causes a false echo reading. ■ Heavy coating or contamination on the probe. Clean the probe.
Level stuck in empty.	<ul style="list-style-type: none"> ■ Thresholds may be too high, see “Adjusting thresholds” on page 94.
Level fluctuations (a couple of inches).	<ul style="list-style-type: none"> ■ There is too much disturbing noise in the tank (from foam, splashing etc.). Set the Performance Mode to High to get a stable measurement signal, refer to “Noise or weak surface echoes” on page 106. ■ There are rapid level changes in the tank. Select a faster Update Rate, refer to “Configure update rate” on page 67. ■ Thin oil layer on top of water that is sometimes detected, sometimes not. Set the Peak Detection Method to Threshold Intersection to improve the stability of level measurements in such applications. Refer to “Resolving thin oil layers” on page 100.

6.3.2 Incorrect or missing interface level reading

Symptom	Possible cause and recommended actions
Incorrect Interface Level reading.	<ul style="list-style-type: none"> ■ The Upper Product Dielectric Constant is not correct, see “Upper product dielectric constant” on page 163. ■ Air gap is too big when the Measurement Mode is set to Interface Level with Submerged Probe. Reduce air gap or switch the Measurement Mode to Product Level and Interface Level.
Missing Interface Level reading (reported as NaN).	<ul style="list-style-type: none"> ■ The Measurement Mode is set to Product Level. Set Measurement Mode to Product Level and Interface Level, refer to “Measurement mode” on page 163. ■ The Interface Peak is difficult to detect, because the bottom product has a low dielectric constant, or the signal is attenuated in the upper product. Check Thresholds. For more information, see “Example 2: Interface peak not found” on page 97.
There are two products in the tank, but only the product surface or interface is detected.	<ul style="list-style-type: none"> ■ The upper product is too thin to be detected. No action is needed. See “Interface measurements” on page 119 for minimum interface thickness for different probe types. ■ Check Thresholds, see “Adjusting thresholds” on page 94.
There are two products in the tank, but no readings are reported.	<ul style="list-style-type: none"> ■ Check Thresholds, see “Adjusting thresholds” on page 94.
There is only oil in the tank but the transmitter reports water.	<ul style="list-style-type: none"> ■ Check Thresholds, see “Adjusting thresholds” on page 94. ■ Make sure the Typical Interface Condition is set to Layer at the bottom (thin) if you typically have a thin layer at the bottom, see “Typical interface condition” on page 164.
There is only water in the tank but the transmitter reports oil.	<ul style="list-style-type: none"> ■ Check Thresholds, see “Adjusting thresholds” on page 94. ■ Make sure the Typical Interface Condition is set to Layer on Top (Thin) if you typically have a thin layer at the top, see “Typical interface condition” on page 164.

6.3.3 Power module troubleshooting

Symptom	Possible cause and recommended actions
The Power Module seems to run out of battery very fast.	<ul style="list-style-type: none"> ■ Consider Update Rate, refer to “Configure update rate” on page 67. Selecting a fast update rate has an impact on Power Module life. ■ Consider Performance Mode, refer to “Performance mode” on page 167. The Power Module life is reduced if Performance Mode is set to High. ■ Check that Power Mode is set to Normal, see “Power mode” on page 167. ■ Verify device is not installed in extreme temperatures. ■ Verify that device is not a network pinch point.

6.3.4 Device display troubleshooting

Symptom	Possible cause and recommended actions
The device display is not functioning.	<ul style="list-style-type: none"> ■ Display Mode is set to Disabled. Set Display Mode to On Demand or Periodic, refer to “Display mode” on page 165. ■ Reseat the device display according to “Utilize the device display” on page 56.

6.3.5 Wireless network troubleshooting

Symptom	Possible cause and recommended actions
The device is not joining the wireless network.	<ul style="list-style-type: none"> ■ Verify Network ID and Join Key. The Network ID and Join Key in the device must match the Network ID and Join Key of the Gateway, refer to “Obtain network ID and join key” on page 67 and “Enter network ID and join key” on page 68. ■ Enable High Speed Operation on the Wireless Gateway. ■ Check Power Module. ■ Verify that Active Advertising has been enabled on the Wireless Gateway. ■ Verify device is within range of at least one other wireless device or the Wireless Gateway, see “Network join details” on page 99. ■ Verify device is configured to join. Send the “Join Now” command to the device, see “Network join details” on page 99. ■ See the Troubleshooting section in the Gateway Reference Manual for more information.
Limited Bandwidth error	<ul style="list-style-type: none"> ■ Reduce the Update Rate on transmitter, refer to “Configure update rate” on page 67. ■ Increase communication paths by adding more wireless points. ■ Check that device has been online for at least an hour. ■ Check that device is not routing through a “limited” routing node. ■ Create a new network with an additional Wireless Gateway.

6.4 Service and troubleshooting tools

This section briefly describes tools and functions in the AMS Wireless Configurator and Field Communicator which may be useful for service and troubleshooting of Rosemount™ 3308 Series Transmitter.

6.4.1 Reading the echo curve

The AMS Wireless Configurator and Field Communicator have powerful tools for advanced troubleshooting. By using the Echo Curve function you get a view of the tank signal. Measurement problems can be solved by studying the position and amplitude of the different peaks.

To read the echo curve:

1. Select **Service Tools > Echo Tuning > Echo Curve**.
2. *AMS Wireless Configurator:* In the dialog box, select **Next >** to start reading the echo curve. The reading may take several minutes.

Field Communicator: Select **Echo Curve Graph** and follow the on-screen instructions. The reading may take several minutes.

Figure 6-2. Echo Curve Plot in AMS Wireless Configurator

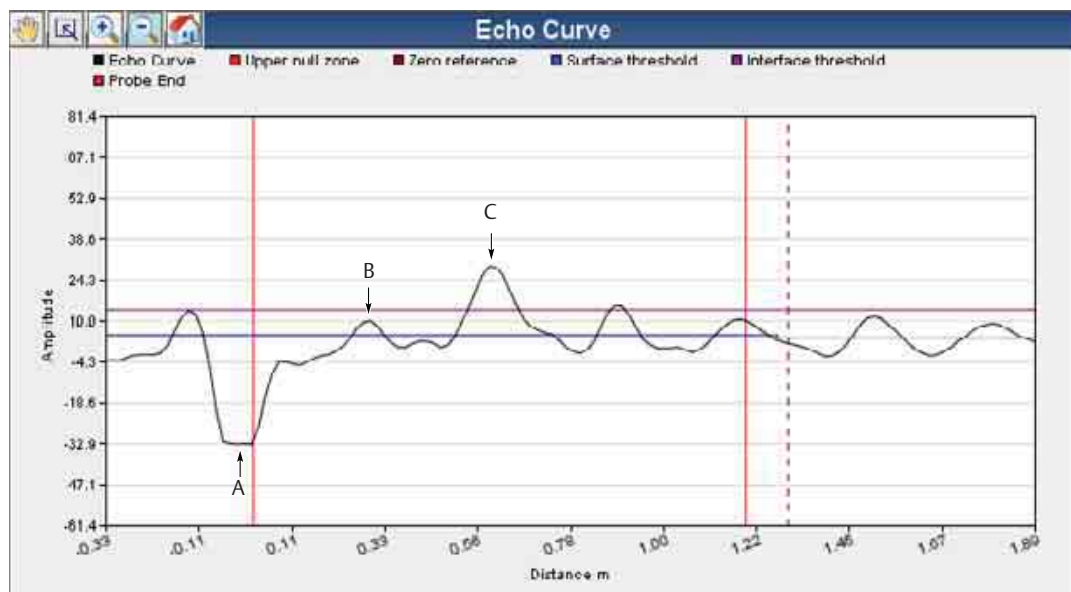

- A. Reference Peak
- B. Product Surface Peak
- C. Interface Peak

6.4.2 Adjusting thresholds

Measurement with the Rosemount 3308 is based on the fact that the radar signal pulses are reflected by the product surface and the interface between two liquids. Signal amplitude thresholds are used to separate the measurement signal from disturbing echoes and noise.

By default, the amplitude thresholds are automatically adjusted to appropriate values in order to filter out noise and other non-valid measurements from the measurement signal, as illustrated in Figure 6-3. The configured Upper Product Dielectric Constant is used for setting the automatically calculated amplitude thresholds. Normally no other threshold adjustment is needed. But if the transmitter still does not track for example the product surface, it may be necessary to manually adjust the thresholds.

Figure 6-3. Threshold Principle

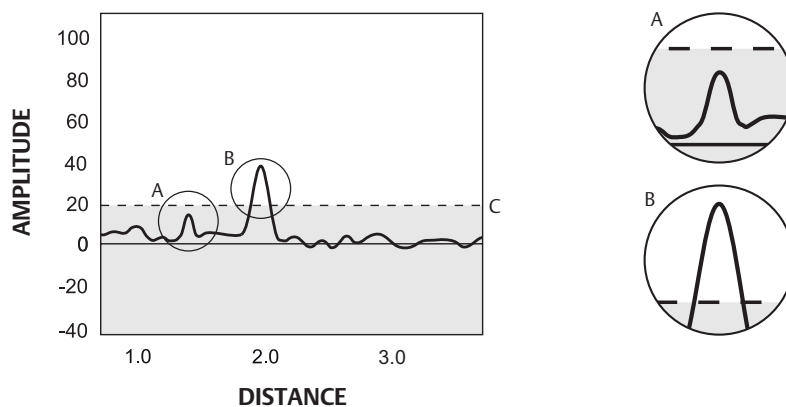

- A. The echo peak is below the threshold (dotted line) and is suppressed by the device.
- B. This echo peak is interpreted as the product surface, since it is the first peak closest to device that is above the surface threshold.
- C. Threshold

The different amplitude thresholds used for the Rosemount 3308 Series Transmitter are described in section “Thresholds” on page 176.

Note

Before changing the amplitude thresholds, check that the Upper Product Dielectric Constant parameter is set as accurately as possible. The Upper Product Dielectric Constant is used for setting the automatically calculated amplitude thresholds.

Guidelines for setting the surface threshold

Before changing the Surface Threshold, make sure the product level is at least 20 in. (0.5 m) from the lower side of the device flange.

- Set the Surface Threshold to about $\frac{1}{3}$ of the weakest surface echo amplitude in the measuring range.

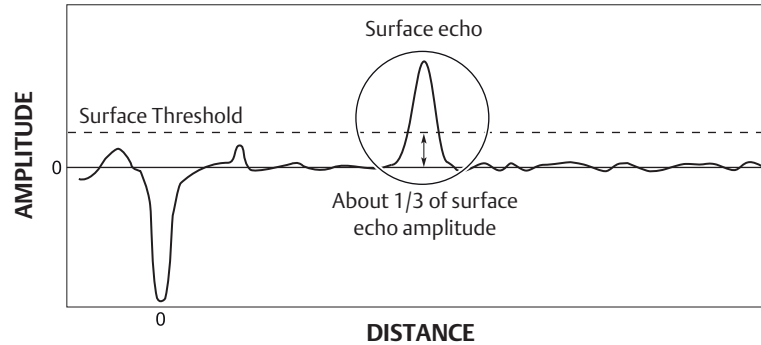

- Surface Thresholds should never be set to values less than 4 Cnts.
- Make sure to include a 3 Cnts margin between the Surface Threshold and the surface echo amplitude over the entire measuring range.

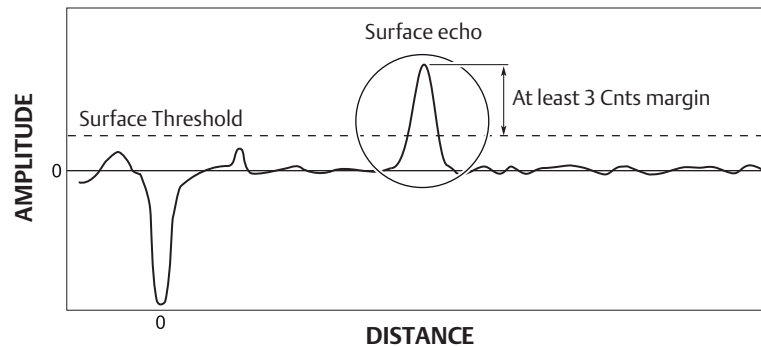

- The Surface Threshold should be at least 3 Cnts greater than the amplitude of disturbances.

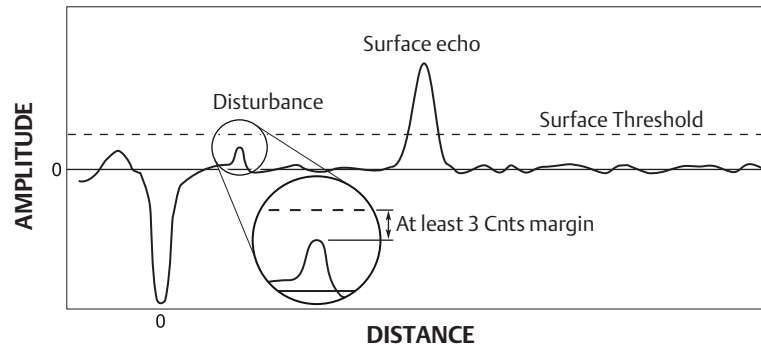

Contact your local Emerson™ representative if the transmitter is still having difficulties to track the product surface after applying the guidelines.

Guidelines for setting the interface threshold

- The Interface Threshold should be approximately 50% of the interface signal amplitude.
- If possible, Interface Threshold should be higher than Surface Threshold.

Procedure for adjusting thresholds

To adjust the amplitude thresholds:

1. Read the Echo Curve.
 - a. Start the Echo Curve reading, refer to “Reading the echo curve” on page 93.
 - b. View the Echo Curve plot and check the relation between amplitude threshold and corresponding signal amplitude peak.
2. Adjust the Threshold.
 - a. Select **Service Tools > Echo Tuning > Thresholds**.
 - b. Under *Threshold Control*, select **User Defined**.
 - c. If using Field Communicator, select **Send**. The Threshold values can now be changed.
 - d. Select desired Threshold to adjust, type the new value into the box, and then select **Send**. See also “Guidelines for setting the surface threshold” on page 95.

Restore default thresholds

1. Select **Service Tools > Echo Tuning > Thresholds**.
2. Under *Threshold Control*, select **Default (Automatic)**, and then select **Send**.

Example 1: Product surface peak not found

If the transmitter does not track the product surface correctly, it may be necessary to adjust the threshold values. In Figure 6-4, the Surface Threshold is too high and as a result the product level will not be detected. In a situation like this, the Surface Threshold has to be lowered so that the surface peak is not filtered out.

Figure 6-4. Surface Threshold Is Too High

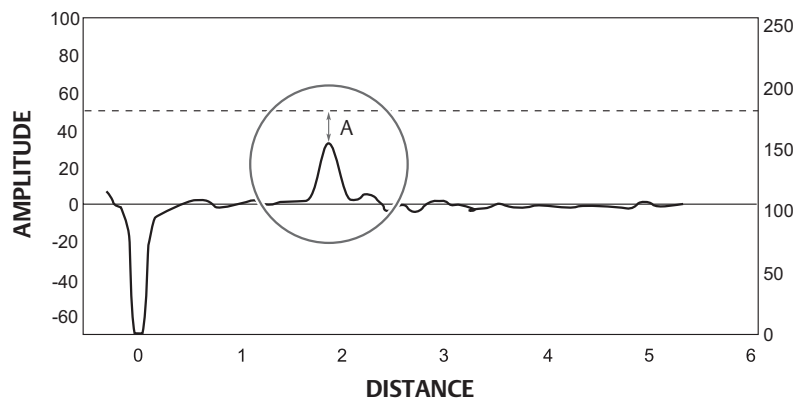

- A. Surface Threshold is above the Product Surface peak.

If there are disturbing objects in the tank, the Surface Threshold must be carefully set to avoid locking on the wrong amplitude peak. In [Figure 6-5](#), the Surface Threshold is too low, and as a result the transmitter has locked on a peak above the actual product surface. A disturbance was interpreted as the product surface, since this was the first amplitude peak closest to device that went above Surface Threshold. The actual product surface was interpreted as the interface or the probe end.

Figure 6-5. Surface Threshold Is Too Low

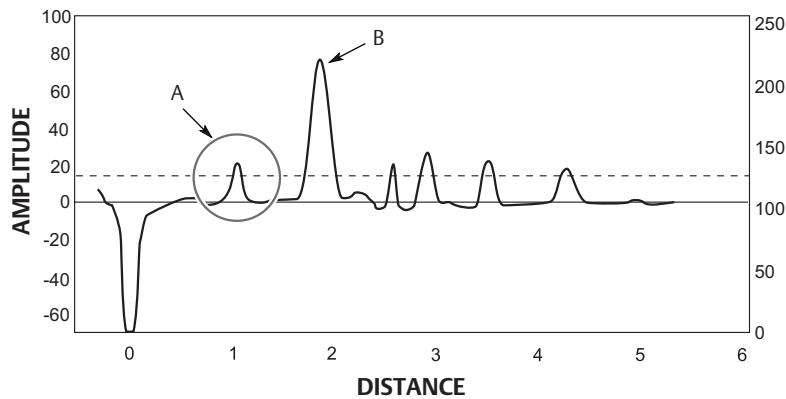

- A. Disturbing echo misinterpreted as product surface
- B. Actual product surface

By adjusting the Surface Threshold the product surface is properly detected as illustrated in [Figure 6-6](#).

Figure 6-6. Echo Curve Plot after Surface Threshold Was Adjusted

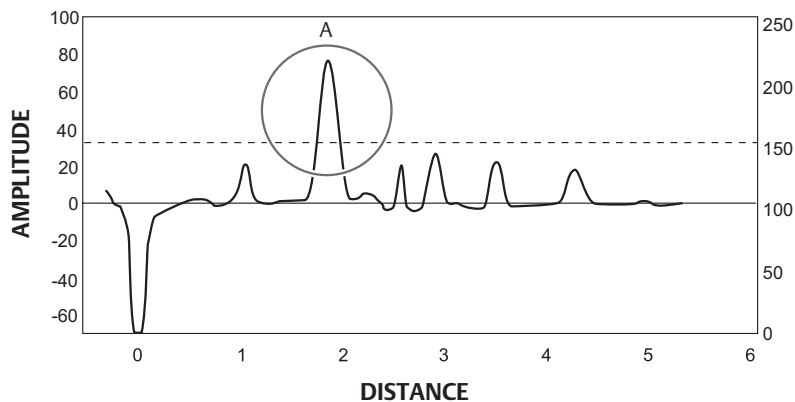

- A. After Surface Threshold is adjusted the product surface is correctly detected.

Example 2: Interface peak not found

In interface applications where the bottom product has a relatively low dielectric constant (<40), or if the signal is attenuated in the upper product, the amplitude of the reflected signal from the interface is relatively low and difficult for the transmitter to detect. In such a case it may be possible to detect the reflected signal from the interface if the Interface Threshold is adjusted.

[Figure 6-7](#) illustrates a situation where the Interface Threshold is too high. The signal amplitude peak at the interface between the upper and lower products is not detected in this case.

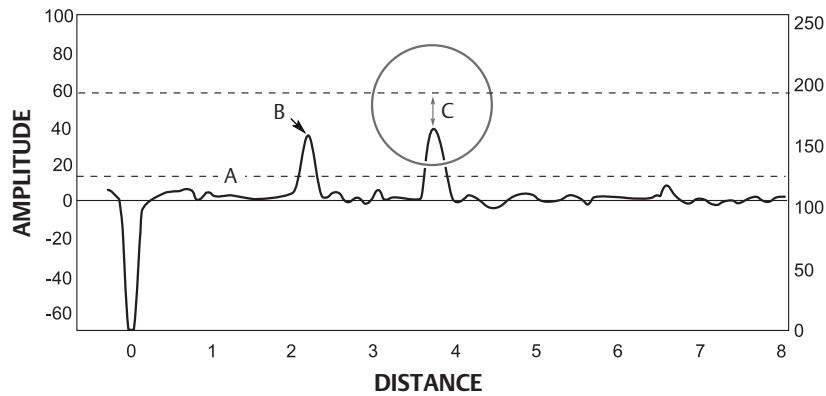
Figure 6-7. Echo Curve Plot Indicating that the Interface Threshold for the Interface Peak Is Too High

- A. Surface Threshold
- B. Product Surface Peak
- C. The Interface Threshold is above the Interface Peak.

By adjusting Interface Threshold, the peak at the interface between the upper and lower products is detected as illustrated in [Figure 6-8](#).

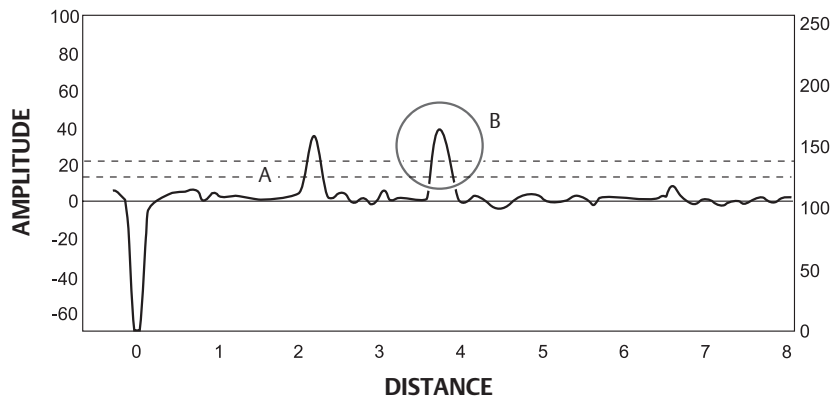
Figure 6-8. After Changing the Interface Threshold the Transmitter Detects the Interface

- A. Surface Threshold
- B. After Interface Threshold is adjusted the interface is correctly detected.

6.4.3 Viewing measurement history

The Measurement History tool presents historical values and related device status that are stored in the transmitter memory. The tool is useful for verifying that the transmitter works properly or to diagnose any issues during a specific time interval.

1. Select **Service Tools > Maintenance > Routine Maintenance**.
2. Select **Measurement History** and follow the on-screen instructions.

6.4.4 Reviewing network join status and details

Network join status

Wireless devices join the network through a four step process:

Step 1. Network Found

Step 2. Network Security Clearance Granted

Step 3. Network Bandwidth Allocated

Step 4. Network Join Complete

To view the Network Join Status of the device:

- Select **Service Tools > Communications > Network Join Status**.

Network join details

Obtain detailed information about the network join, and configure how the device attempts to join the network.

- Select **Service Tools > Communications > Join Details**.

Table 6-5. Network Join Details

Term	Description
Join Mode	This mode configures how the device attempts to join the network. Settable options are: <ul style="list-style-type: none"> • Don't Attempt to Join • Join Now • Join on Powerup or Reset
Number of Available Neighbors	Defines how many wireless devices are within the communication range of this device. In a self-organizing network, the more neighbors a device has, the more robust the network will be.
Number of Advertisements Heard	Number of advertised packets received by the device from all networks within range.
Number of Join Attempts	Number of times the device has tried to join the network prior to being accepted. Too many join attempts result in the device considering the join attempt as failed. If this happens, re-check the Join Key and Network ID.

6.4.5 Locating the device

Use the Locate Device function to identify this device by showing a pattern on the device display, as illustrated in [Figure 6-9](#).

1. Select **Service Tools > Maintenance > Routine Maintenance**.
2. Select **Locate Device** and follow the on-screen instructions.

Figure 6-9. Locate Device Pattern

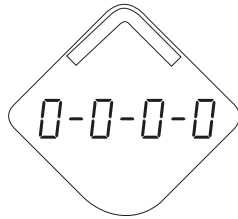

6.4.6 Using the simulation mode

This function can be used to simulate measurements and alerts.

1. Select **Service Tools > Simulate**.
2. Select desired variable and follow the on-screen instructions.

6.4.7 Using the verification method

The Verification method is used to verify distance measurement with the Rosemount VeriCase.

1. Select **Service Tools > Maintenance > Routine Maintenance**.
2. Select **Verification** and follow the on-screen instructions.

Refer to the Rosemount VeriCase [User Guide](#) for instructions on how to use the mobile verification tool.

6.5 Application challenges

6.5.1 Resolving thin oil layers

Thin oil layer on top of water might cause jumpy surface readings. Because of the thin oil layer, the transmitter varies between detecting oil and water. Sometimes the oil layer gets too thin to be detected. See [Figure 6-10](#).

Figure 6-10. Thin Oil Layer on Top of Water, Peak Detection Method Set to Peak Center

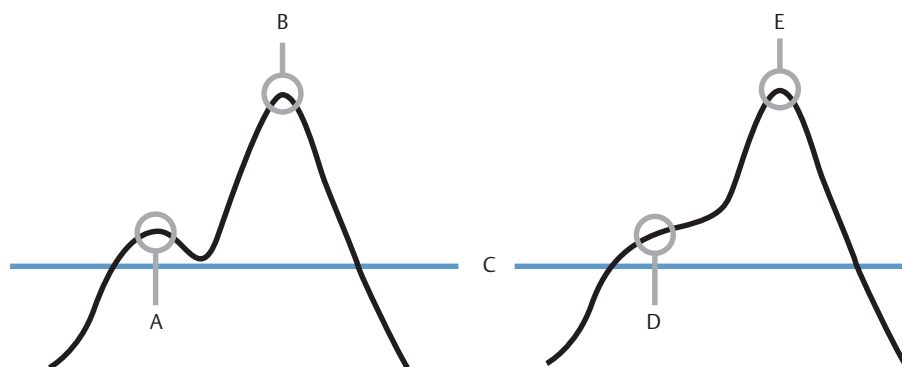

- A. Oil peak detected as surface
- B. Water peak
- C. Surface Threshold
- D. Too thin oil layer, no peak
- E. Water peak detected as the surface

The surface readings in such applications will be stabilized by setting the Peak Detection Method to Threshold Intersection. The point used for level measurement is then changed, see [Figure 6-11](#). Note that this configuration should only be performed by advanced users as it could cause issues if configured incorrectly.

Figure 6-11. The Different Peak Detection Methods

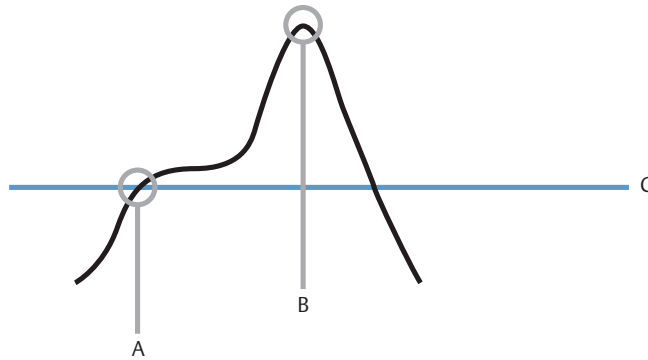

- A. Threshold Intersection: Surface detected at first intersection with Surface Threshold
- B. Peak Center
- C. Surface Threshold

To set the Peak Detection Method to Threshold Intersection:

1. Select **Service Tools > Echo Tuning > Advanced**.
2. Under *Peak Detection Method*, select **Threshold Intersection**, and then click **Send**.
3. Run Verify Level to compensate for any offset error (see [Figure 6-12](#)) introduced by the Threshold Intersection method. See “[Verify level](#)” on page 74 for further instructions.

Figure 6-12. Thin Oil Layer on Top of Water, Peak Detection Method Set to Threshold Intersection

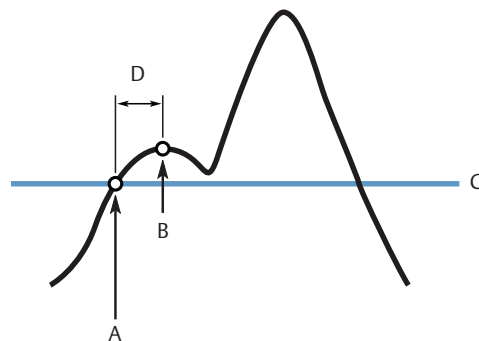

- A. Surface detected at first intersection with Surface Threshold, even when there is an oil peak
- B. Actual product surface is ignored
- C. Surface Threshold
- D. Offset error

6.5.2 Handling disturbances at the top of the tank

Adjusting the near zone threshold

The Near Zone Threshold is used to filter out disturbing echoes and noises at the top of the tank. By default, this threshold is automatically calculated by the device, and is sufficient in most conditions.

However, in the case of unfavorable conditions, you might need to manually set the Near Zone Threshold. This may for example be the case if a Single Lead probe is mounted in a narrow nozzle, if the end of the nozzle protrudes into the tank, or if there are disturbing obstacles in the Near Zone (referred to as the region between 0-3.3 ft. (0-1 m) below the Upper Reference Point).

Figure 6-13. Near Zone Threshold

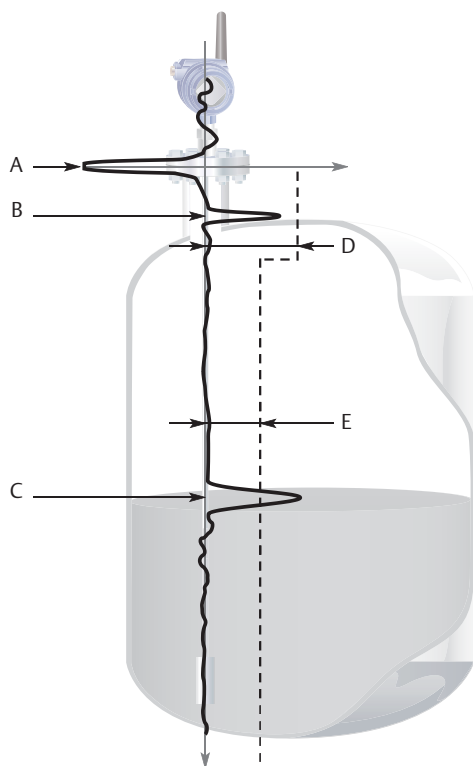

- | | |
|-------------------------|---|
| A. Reference Peak | D. Near Zone Threshold blocking the disturbance |
| B. Disturbance | E. Surface Threshold |
| C. Product Surface Peak | |

Guidelines for setting the near zone threshold

- The Near Zone Threshold must be higher than the Surface Threshold to have an effect. The threshold in the near zone is set to the highest value of the configured Near Zone Threshold and Surface Threshold.
- The margin to waveform disturbances and noise must be at least 3 Cnts.

Procedure

To manually set the Near Zone Threshold function:

1. Read the Echo Curve.
 - a. Start the Echo Curve reading, refer to [“Reading the echo curve”](#) on page 93.
 - b. View the Echo Curve plot to find out if there are disturbing echoes close to the tank top.

2. Set the Near Zone Threshold.
 - a. Select **Service Tools > Echo Tuning > Near Zone > Near Zone Threshold**.
 - b. Under *Threshold Control*, select **User Defined**.
 - c. If using Field Communicator, select **Send**. The Threshold and End Distance values can now be changed.
 - d. Under *Threshold*, type the desired value into the box.
 - e. Under *End Distance*, type the desired value into the box. This value is the distance from Upper Reference Point to point where the Near Zone Threshold ends.

Using the trim near zone function

The Trim Near Zone function is used to fine tune performance in the area close to the tank top. Normally it is not necessary to use the function, but if you experience problems related to the nozzle, pipe, or chamber installation, you may need to use this function.

Figure 6-14 describes the Trim Near Zone function and its effect on the echo curve. This effect is only visible if measurement conditions so require.

Figure 6-14. Echo Curve before and after Trim Near Zone

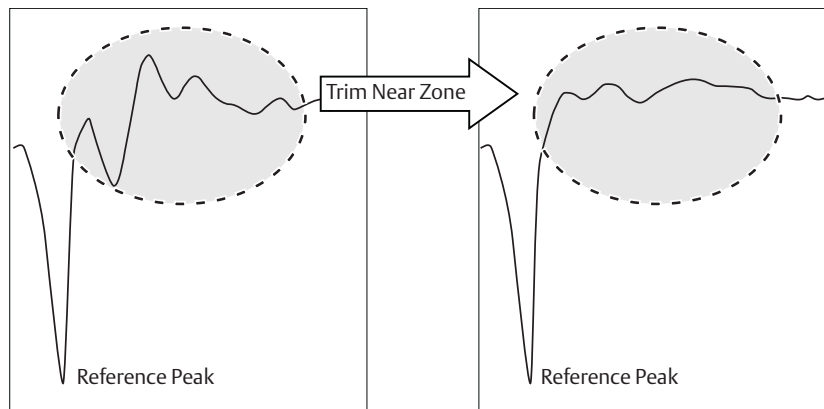

Note

Make sure the product level is below the Near Zone region (0-3.3 ft. (0-1 m) below the Upper Reference Point) before performing the Trim Near Zone.

Note

The Trim Near Zone function should only be used for reducing impact from stationary disturbances. For occasional disturbances, use the Near Zone Threshold.

To use the Trim Near Zone function:

1. Select **Service Tools > Echo Tuning** and click **Near Zone**.
2. Under *Near Zone Compensation*, select **Trim Near Zone** and follow the on-screen instructions.

Changing the upper null zone

Measurements are not performed within the Upper Null Zone (UNZ). The Upper Null Zone can be extended to block out disturbing echoes close to the tank top, caused by for example a narrow nozzle with rough walls, obstacles close to the probe, or a nozzle that protrudes into the tank. See Figure 6-16.

Note

Desired measuring range must be below the Upper Null Zone.

Note

Before changing the Upper Null Zone, check entered limit and deadband values for the High Level Alerts. High Level Alerts should not be placed in the Upper Null Zone.

To set the Upper Null Zone:

1. Identify desired Upper Null Zone using the Echo Curve plot.
 - a. Start the Echo Curve reading, refer to “Reading the echo curve” on page 93.
 - b. View the Echo Curve plot to find out if there are disturbing echoes close to the tank top.
2. Set the desired Upper Null Zone value.
 - a. Select **Configure > Manual Setup > Level Setup > Probe > Advanced Probe Options**.
 - b. Under *Upper Null Zone*, type the desired value into the box, and then select **Send**.

Figure 6-15. Upper Null Zone

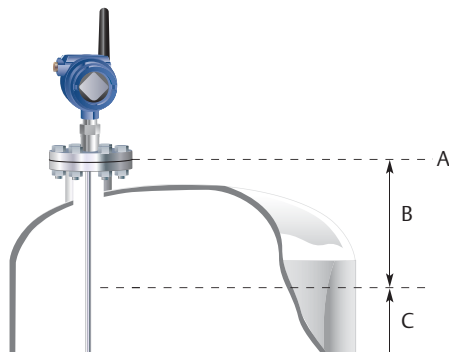

- A. Upper Reference Point
- B. Upper Null Zone
- C. Measurement Range

Figure 6-16. Upper Null Zone Is Extended to Block Out Disturbances at the Top of the Tank

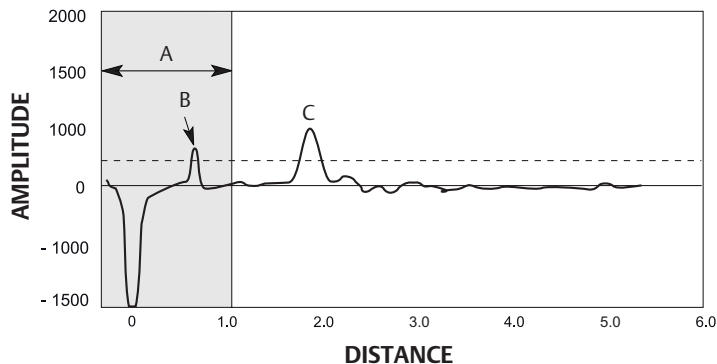

- A. Upper Null Zone
- B. Disturbance
- C. Product Surface Peak

6.5.3 Interface measurements with fully submerged probes

The Measurement Mode Interface Level with Submerged Probe is used to handle interface measurements when the product level is not visible, for example in a full chamber pipe as illustrated in [Figure 6-17](#). In this case the probe is fully submerged into the upper product, and only the interface level is detected by the transmitter.

Even if the upper product level drops, it is ignored by the transmitter which continues to measure only the interface level. If the product level drops, the air filled region in the upper part of the pipe will slightly reduce the measurement accuracy of the interface level. To achieve high accuracy in this Measurement Mode the probe must be fully submerged.

To set the Measurement Mode to Interface Level with Submerged Probe:

1. Select **Configure > Manual Setup > Level Setup > Environment**.
2. Under *Measurement Mode*, select **Interface Level with Submerged Probe (Interface Only** in Field Communicator), and then select **Send**.

Note

Do not set Measurement Mode to Interface Level with Submerged Probe in “standard” applications when both Product Level and Interface Level are measured.

Figure 6-17. Interface Level Measurements in a Full Chamber

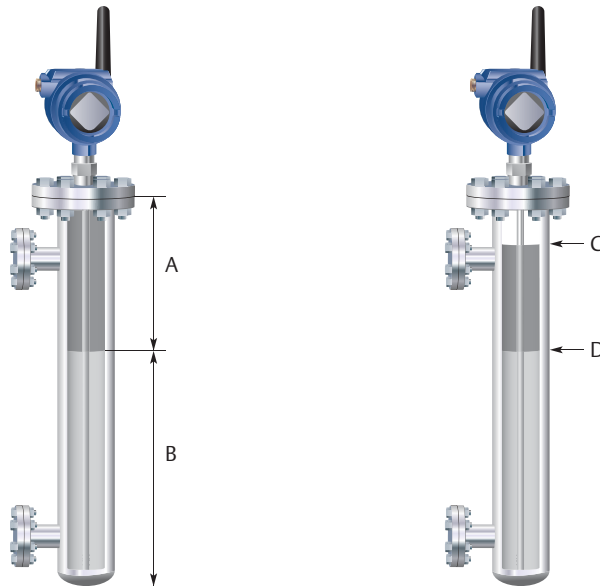

- A. Interface distance
- B. Interface level
- C. Product level is ignored
- D. Interface level is measured

Note

Adjust Interface Threshold if the interface level pulse is not detected.

6.5.4 Noise or weak surface echoes

In difficult applications where the surface echo peak is low compared to the noise, it is recommended to set the Performance Mode to High Performance. A low surface peak compared to the noise might be caused by a turbulent surface, foam, low dielectric constant, plastic tanks, and so on.⁽¹⁾

If the Performance Mode is set to High Performance, each update is based on an increased number of measurements (radar sweeps), which gives improved accuracy and robustness, as well as decreased noise in the output value. However, the battery life is significantly reduced (between 40-60 percent).

1. Select **Service Tools > Echo Tuning > Advanced**.
2. Under *Performance Mode*, select **High Performance**, and then select **Send**.

6.6 Power module replacement

Replace the power module with a new Black Power Module, SmartPower™ Solutions model number 701PBKKF.

1. Replace the power module.

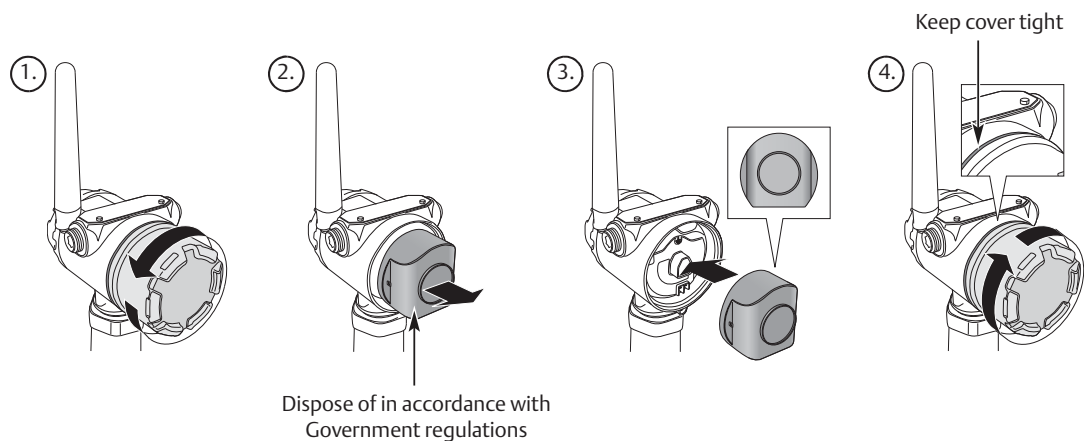

2. In AMS Wireless Configurator or Field Communicator, run Install New Power Module setup.
 - a. Select **Service Tools > Maintenance > Routine Maintenance**.
 - b. Select **Install New Power Module** and follow the on-screen instructions.

1. The High Performance mode is not supported on all models.

Handling considerations

The Black Power Module with the wireless unit contains two "C" size primary lithium/thionyl chloride batteries. Each battery contains approximately 2.5 grams of lithium, for a total of five grams in each Power Module. Under normal conditions, the battery materials are self-contained and are not reactive as long as the batteries and the battery pack integrity are maintained. Care should be taken to prevent thermal, electrical or mechanical damage. Contacts should be protected to prevent premature discharge.

Use caution when handling the power module, it may be damaged if dropped from heights in excess of 20 ft. (6 m).



Battery hazards remain when cells are discharged.

Environmental considerations

As with any battery, local environmental rules and regulations should be consulted for proper management of spent batteries. If no specific requirements exist, recycling through a qualified recycler is encouraged. Consult the materials safety data sheet for battery specific information.

Shipping considerations

The unit was shipped to you without the power module installed. Please remove the power module prior to shipping.

Each Black Power Module contains two "C" size primary lithium batteries. Primary lithium batteries are regulated in transportation by the U.S. Department of Transportation, and are also covered by International Air Transport Association (IATA), International Civil Aviation Organization (ICAO), and European Ground Transportation of Dangerous Goods (ARD). It is the responsibility of the shipper to ensure compliance with these or any other local requirements. Please consult current regulations and requirements before shipping.

6.7 Transmitter head replacement

Figure 6-18. Transmitter Head Replacement

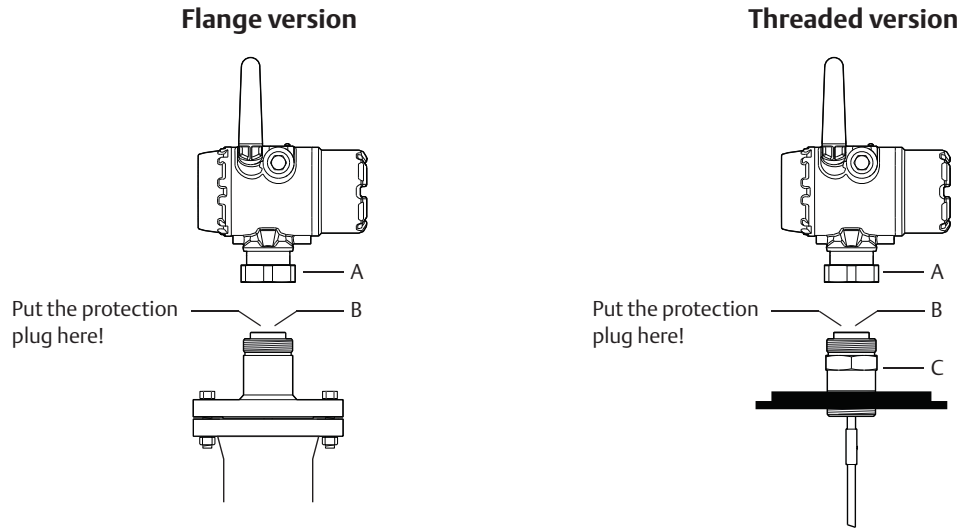

- A. Nut
- B. Process Seal
- C. Adapter

1. Loosen the nut that connects the transmitter head to the process seal.
2. Carefully lift the transmitter head.
3. On the probe, make sure that the upper surface of the process seal is clean and free from dust and water. Wipe it clean with a dry and lint-free cloth.
4. Verify the spring-loaded pin at the center of the process seal is properly inserted. When inserted properly only the plunger is seen above the edge inside the seal hole.

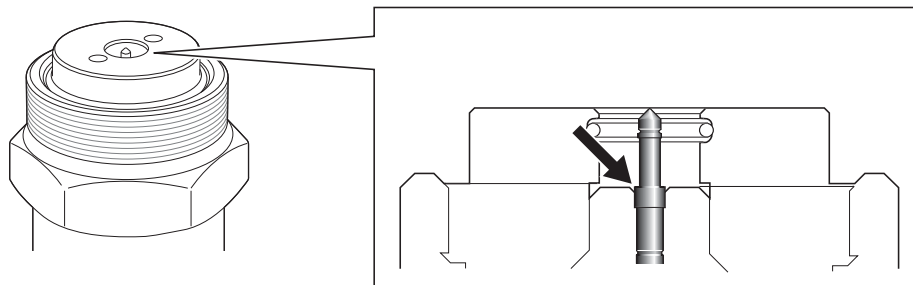

5. If the transmitter head is not mounted directly, attach the protection plug to the process seal to protect the exposed parts from dust and water. If a protection plug is not available, then cover the process seal with a plastic bag.
6. Rotate the new transmitter head so the device display faces the desired direction.
7. Tighten the nut. Max torque is 30 Lbft (40 Nm).
8. Configure the transmitter, refer to [Section 4: Configuration](#).

6.8 Probe replacement

Figure 6-19. Probe Replacement

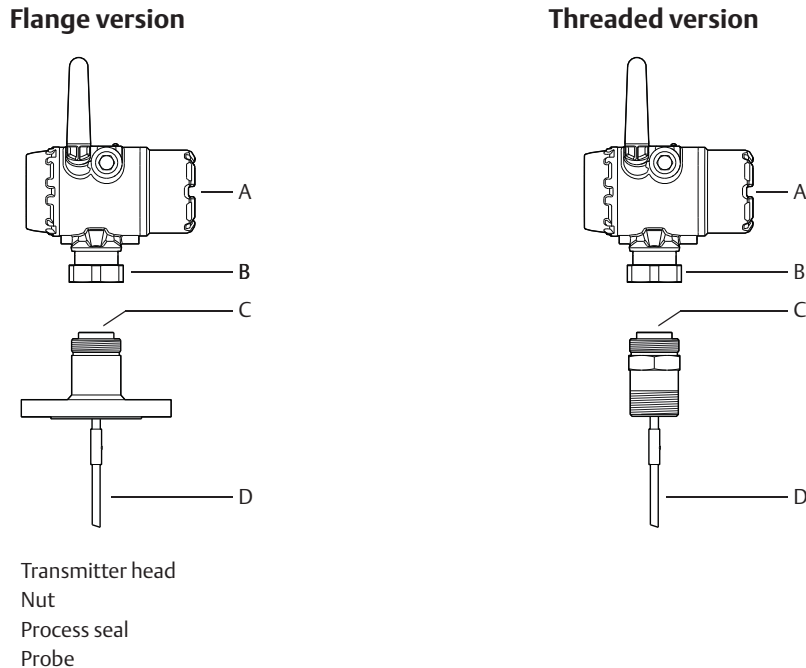

1. Loosen the nut.
2. Remove the transmitter head from the old probe. Make sure to protect the transmitter head bottom from dust and water.
3. On the new probe, make sure that the protection plug is removed and the upper surface of the Process Seal is clean. Also make sure that the spring-loaded pin at the center of the Process Seal is properly inserted.
4. Mount the transmitter head on the new probe.
5. Tighten the nut. Max torque is 30 Lbft (40 Nm).
6. If the new probe is not of the same type as the old one, update the transmitter configuration by setting the Probe Type parameter to the appropriate value.
 - a. Select **Configure > Manual Setup > Level Setup > Probe**.
 - b. Under *Probe Type*, select desired Probe Type.
7. Measure the Probe Length and enter the measured value.
 - a. Select **Configure > Manual Setup > Level Setup > Probe**.
 - b. Under *Probe Length*, enter the measured Probe Length value.
8. Run Verify Level to check your level measurement, refer to “Verify level” on page 74.

6.9 Service support

To expedite the return process outside of the United States, contact the nearest Emerson representative.

Within the United States, call the Emerson Instrument and Valve Response Center using the 1-800-654-RSMT (7768) toll-free number. This center, available 24 hours a day, will assist you with any needed information or materials.

The center will ask for product model and serial numbers, and will provide a Return Material Authorization (RMA) number. The center will also ask for the process material to which the product was last exposed.

⚠ CAUTION

Individuals who handle products exposed to a hazardous substance can avoid injury if they are informed of and understand the hazard. Returned products must include a copy of the required Material Safety Data Sheet (MSDS) for each substance.

Emerson Instrument and Valve Response Center representatives will explain the additional information and procedures necessary to return goods exposed to hazardous substances.

NOTICE

Shipping considerations for wireless products.

The unit was shipped to you without the Power Module installed. Please remove the Power Module prior to shipping the unit.

Each Power Module contains two "C" size primary lithium/thionyl chloride batteries. Primary lithium batteries (charged or discharged) are regulated during transportation by the U.S. Department of Transportation. They are also covered by IATA (International Air Transport Association), ICAO (International Civil Aviation Organization), and ARD (European Ground Transportation of Dangerous Goods). It is the responsibility of the shipper to ensure compliance with these or any other local requirements. Consult current regulations and requirements before shipping.

Appendix A Specifications and Reference Data

Performance specifications	page 111
Functional specifications	page 116
Physical specifications	page 121
Ordering information	page 124
Spare parts and accessories	page 130
Dimensional drawings	page 139

A.1 Performance specifications

A.1.1 General

Reference conditions

- Probe: Flexible single lead
- Vessel: 4-in. pipe
- Measurement target: Water
- Temperature: 68 to 77 °F (20 to 25 °C)
- Relative humidity: 30-80%

Reference accuracy⁽¹⁾

- High performance (profile code U):
 - ±0.12 in. (±3 mm), when distance < 33 ft. (10 m)
 - ±0.03% of measured distance, when distance > 33 ft. (10 m)
- Standard (profile code S):
 - ±0.2 in. (±5 mm), when distance < 33 ft. (10 m)
 - ±0.05% of measured distance, when distance > 33 ft. (10 m)

Ambient temperature effect

±0.08 in. (±2 mm)/10 K

Electromagnetic interference effect⁽²⁾

- External antenna (WK1 option): < ±0.25 in. (±6 mm)
- Remote (WN1 option): < ±0.2 in. (±5 mm)

Power module battery life⁽³⁾

- High performance: 5 years at one minute update rate
- Standard: 9 years at one minute update rate

1. Refer to the IEC 60770-1 standard for a definition of radar specific performance parameters and if applicable corresponding test procedure.
 2. Deviation through electromagnetic interference according to EN 61326.
 3. Reference conditions are 70 °F (21 °C), and routing data for three additional network devices.

A.1.2 Environment

Vibration resistance

No effect when tested per the requirements of IEC60770-1 (1999): High Vibration Level - field or pipeline (10-60 Hz 0.21 mm displacement peak amplitude / 60-2000 Hz 3g).

Electromagnetic compatibility

- Meets CE 61326:2012 and NE21:2012 if installed in metallic vessels or still pipes.
- For optimal single lead probe performance in non-metallic tanks, the probe must be mounted with a metal flange, or screwed in to a metal sheet (d > 14 in./350 mm) if a threaded version is used. See “Installation in non-metallic tanks and open-air applications” on page 19 for more information.

Pressure Equipment Directive (PED)

Complies with 2014/68/EU article 4.3

Radio approvals

- Radio Equipment Directive (RED) 2014/53/EU
- Part 15 of the FCC Rules
- Industry Canada RSS 211

A.1.3 Interface measuring range

The maximum allowable upper product thickness/measuring range is primarily determined by the dielectric constants of the two liquids.

Typical applications include interfaces between oil/oil-like and water/water-like liquids, with a low (<3) dielectric constant for the upper product and a high (>20) dielectric constant for the lower product. For such applications, the maximum measuring range is limited by the length of the coaxial and rigid single lead probes.

For flexible probes, the maximum measuring range is reduced by the maximum upper product thickness, according to the diagram below. However, characteristics may vary between the different applications.

Figure A-1. Maximum Upper Product Thickness for Flexible Probes

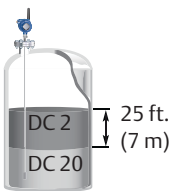
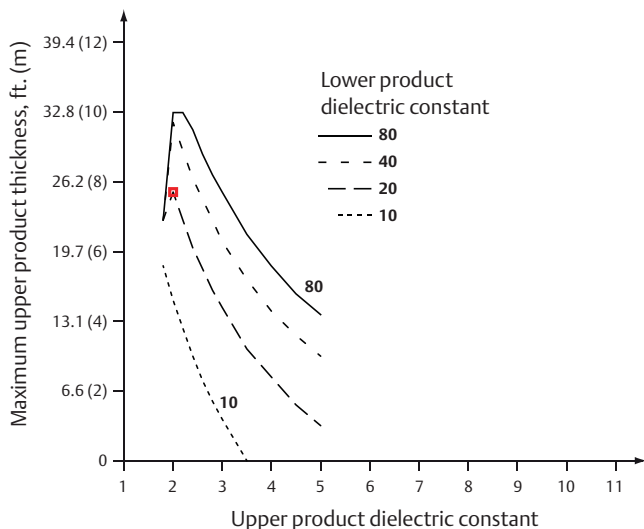

Example: With an upper product dielectric constant of 2, and a lower product dielectric constant of 20, the maximum upper product thickness is 25 ft. (7 m).

Table A-1. Measuring Range and Minimum Dielectric Constant

Probe type	Maximum measuring range	Minimum dielectric constant ⁽¹⁾⁽²⁾
Flexible single lead	55.8 ft. (17 m)	2.0, when distance < 32.8 ft. (10 m) 10, when distance > 32.8 ft. (10 m)
Rigid single lead probe (0.3-in./8 mm)	9.8 ft. (3 m)	2.0
Rigid single lead probe (0.5-in./13 mm)	19.7 ft. (6 m)	2.0
Segmented rigid single lead	32.8 ft. (10 m)	2.0
Flexible twin lead	55.8 ft. (17 m)	2.0, when distance < 32.8 ft. (10 m) 10, when distance > 32.8 ft. (10 m)
Coaxial	19.7 ft. (6 m)	2.0

- Minimum Dielectric Constant may be lower than 2.0 if one or more of the following conditions apply:
 - Probe is installed in stilling well or chamber.
 - Maximum measuring range is not utilized.
 - Noise Threshold is manually adjusted to a lower level.
- For temperatures above 140 °F (60 °C) manual adjustment of noise threshold may be required for products with low dielectric constant at or close to maximum measuring range.

Table A-2. Maximum Recommended Viscosity and Contamination/Build-up

Probe type	Maximum viscosity	Contamination/build-up
Single lead	8000 cP ⁽¹⁾⁽²⁾	Build-up allowed
Twin lead	1500 cP	Thin build-up allowed, but no bridging
Coaxial	500 cP	Not recommended

- Consult your local Emerson representative in the case of agitation/turbulence and high viscous products.
- For viscous or sticky applications, it is not recommended to use centering discs mounted along the probe.

A.1.4 Accuracy over measuring range

The measuring range depends on probe type, dielectric constant of the product and installation environment, and is limited by the Blind Zones at the very top and bottom of the probe. In the Blind Zones, the accuracy exceeds ± 1.18 in. (30 mm), and measurements may not be possible. Measurements close to the Blind Zones will have reduced accuracy.

The following conditions will impact the Blind Zones:

- If the single lead probes or twin probes are installed in a nozzle, the nozzle height shall be added to the specified Upper Blind Zone.
- The measuring range for the PTFE covered flexible single lead probe includes the weight when measuring on a high dielectric media.

Figure A-2, Figure A-3, Figure A-4, and Figure A-5 illustrate the accuracy over measuring range at reference condition using the Trim Near Zone function, with alternating probe types and varying dielectric constant of the product.

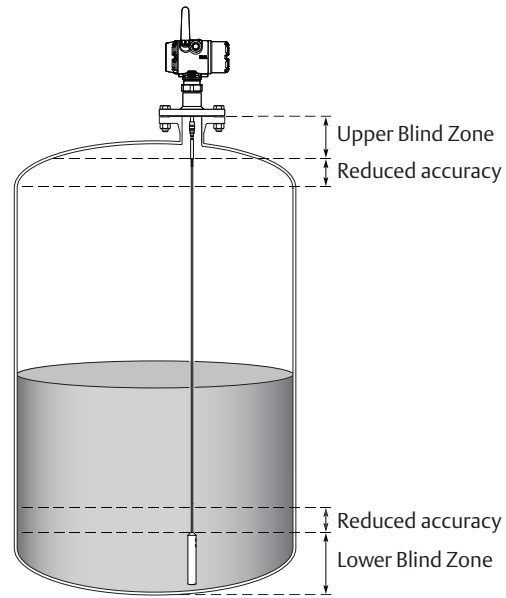

Note

Measurements may not be possible in the Blind Zones, and measurements close to the Blind Zones will have reduced accuracy. Therefore, the alarm points should be configured outside these zones.

Figure A-2. Accuracy over Measuring Range for Flexible Single Lead Probe

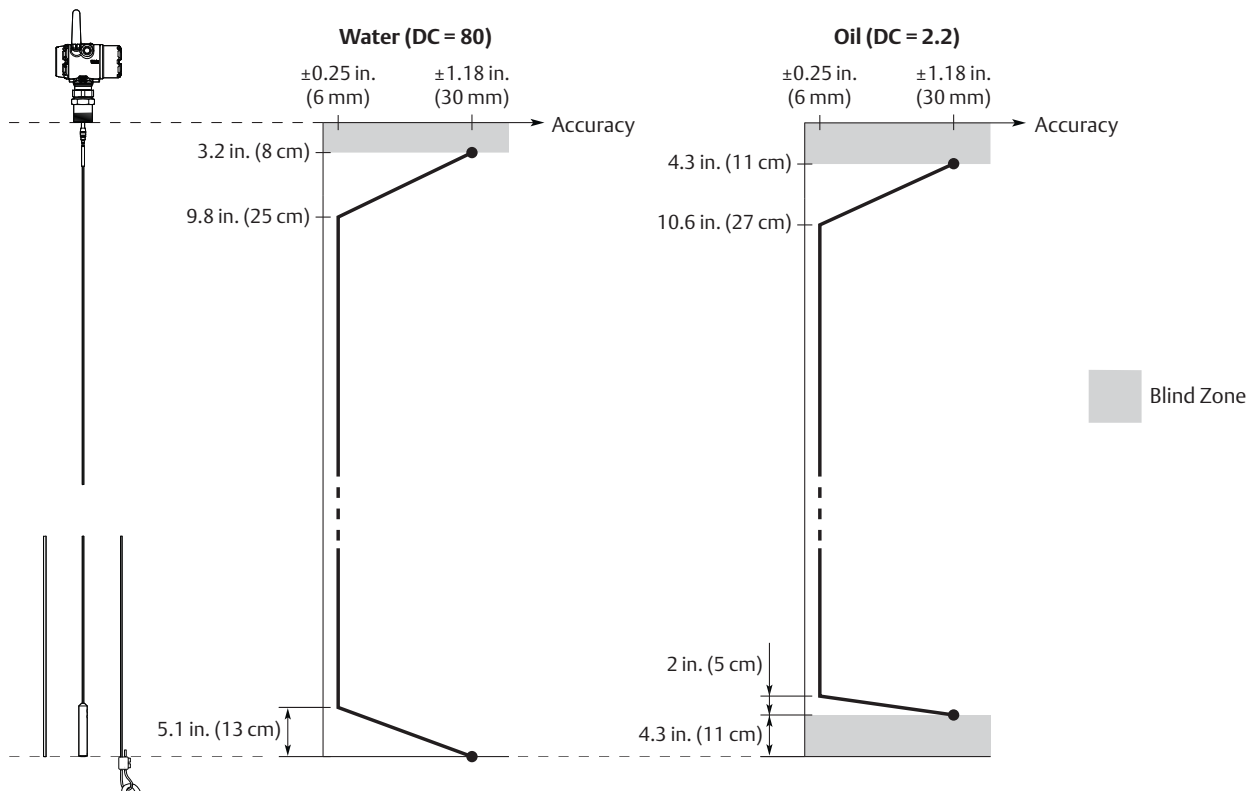

Figure A-3. Accuracy over Measuring Range for Rigid Single Lead/Segmented Rigid Single Probes

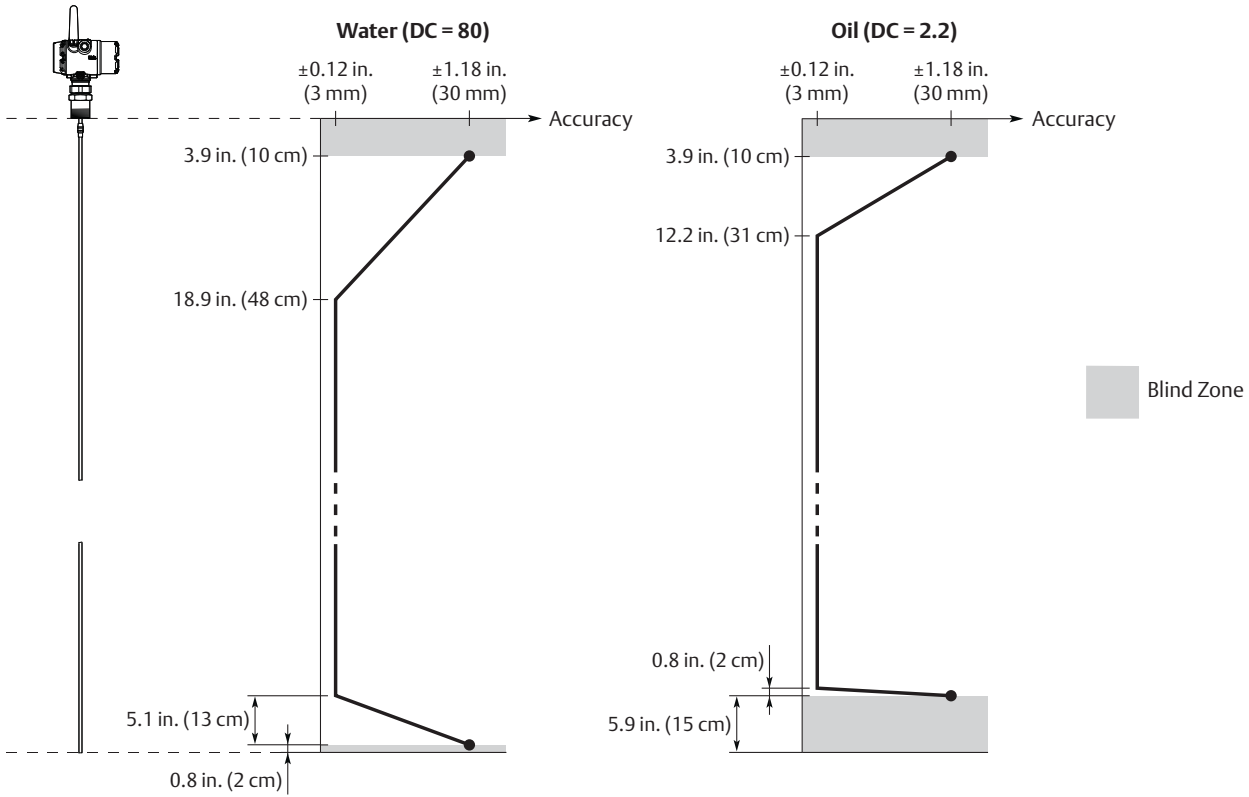

Figure A-4. Accuracy over Measuring Range for Flexible Twin Lead Probe

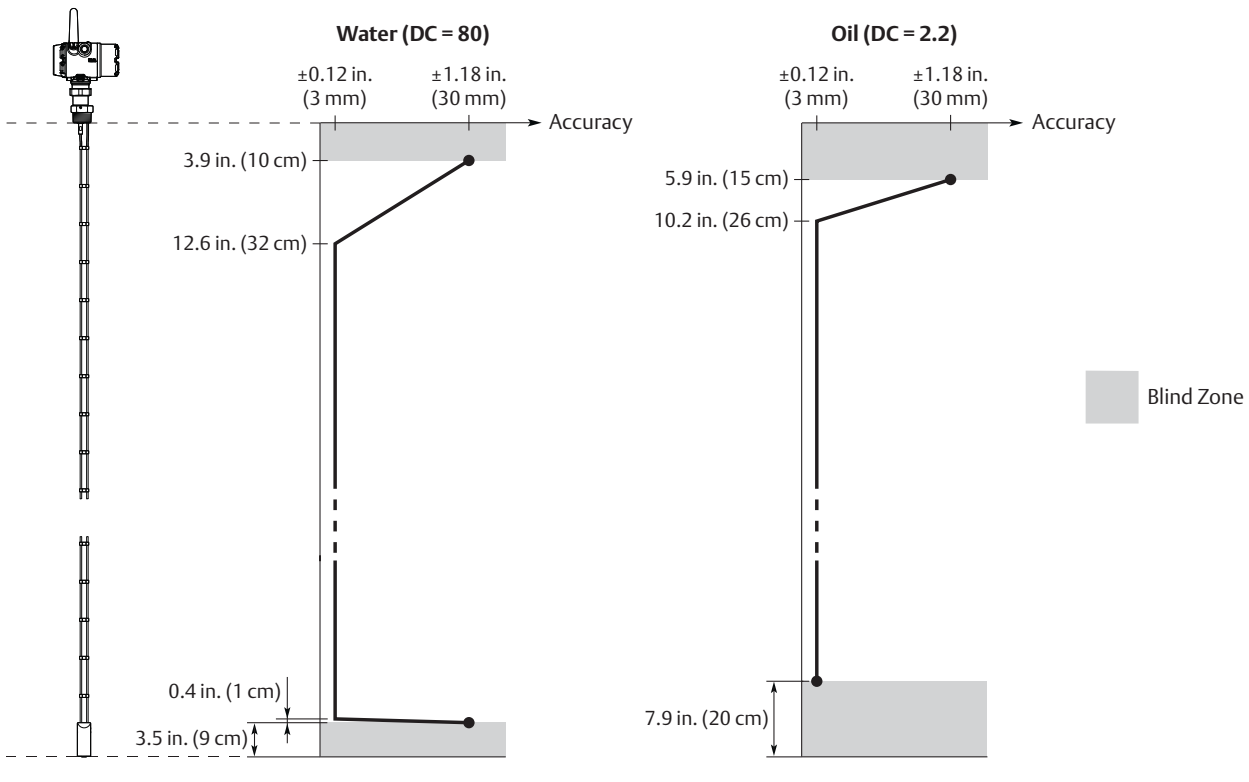
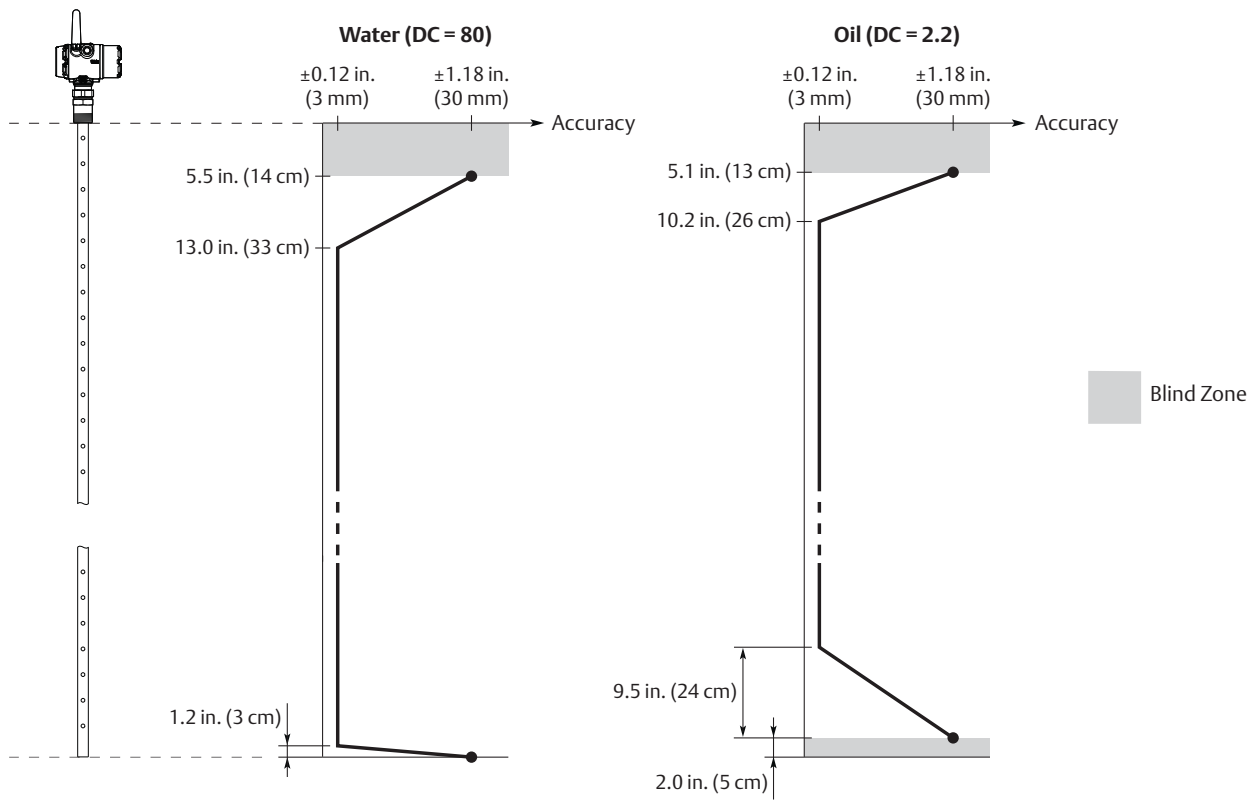

Figure A-5. Accuracy over Measuring Range for Coaxial Probe



A.2 Functional specifications

A.2.1 General

Field of application

Liquids and semi-liquids level or liquid/liquid interfaces

- 3308Axx1... for level or submerged probe interface measurement
- 3308Axx2... for level and interface measurement

Measurement principle

Time Domain Reflectometry (TDR)

(See “Theory of operation” on page 3 for a description of how it works)

Microwave output power

Nominal 10 μ w, Max <20 mW

Humidity limits

0 to 100% relative humidity

A.2.2 Wireless

Output

IEC 62591 (*WirelessHART*[®]) 2.4 GHz DSSS

Transmit rate

User selectable, 4 seconds to 60 minutes

Frequency range

2400 - 2483.5 MHz

Radio frequency output from antenna

- External antenna (WK option): < 10 mW (+10dBm) EIRP
- Remote (WN option): < 40mW (16dBm) EIRP

Modulation type

QPSK/iEEE 802.15.4 DSSS IEC 62591 (*WirelessHART*)

Number of channels

15

Channel spacing

5 MHz

Emission designation

G1D

A.2.3 Display and configuration

LCD display

- Toggles between selected output variables
- Shows diagnostic information (alerts)
- Display updates at each wireless update

Figure A-6. Device Display

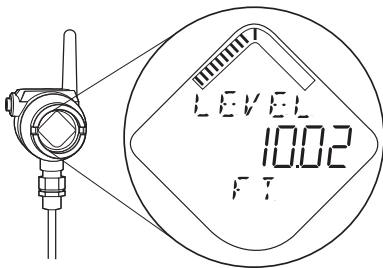

Output units

- Level, Interface, and Distance: ft, inch, m, cm, or mm
- Volume: ft³, inch³, US gals, Imp gals, barrels, yd³, m³, or liters
- Temperature: °F, °C

Table A-3. Output Variables

	LCD display	PV, SV, TV, QV
Level	✓	✓
Distance	✓	✓
Surface Signal Strength	N/A	✓
Total Volume	✓	✓
Interface Level ⁽¹⁾	✓	✓
Interface Distance ⁽¹⁾	✓	✓
Interface Signal Strength ⁽¹⁾	N/A	✓ ⁽²⁾
Upper Product Thickness ⁽³⁾	✓	✓
Electronics Temperature	✓	✓ ⁽²⁾
Signal Quality	✓	✓ ⁽²⁾
Supply Voltage	✓	✓ ⁽²⁾
% of Range	✓	✓ ⁽²⁾

1. For 3308Axx1, Interface measurement is only available for fully submerged probe.
2. Not available as primary variable.
3. Only available with 3308Axx2.

HART diagnostics

Signal Quality Metrics - Diagnostics package that monitors the relations between surface, noise and threshold. The function can be used to detect abnormal conditions in the process such as probe contamination or sudden loss of signal strength. Signal Quality is available as Output Variable and it comes with user configurable alerts through AMS Wireless Configurator or Field Communicator.

A.2.4 Temperature limits

Ambient and storage temperature limits

Verify that the operating atmosphere of the transmitter is consistent with the appropriate hazardous locations certifications, see [Appendix B: Product Certifications](#).

Table A-4. Ambient Temperature Limits

	Operating limit	Storage limit
With LCD Display	-40 to 175 °F (-40 to 80 °C) ⁽¹⁾	-40 to 185 °F (-40 to 85 °C)
Without LCD Display	-40 to 185 °F (-40 to 85 °C)	-40 to 185 °F (-40 to 85 °C)

1. LCD display may not be readable and device display updates will be slower at temperatures below -4 °F (-20 °C).

A.2.5 Process temperature and pressure rating

Figure A-7 gives the maximum process temperature (measured at the lower part of the flange or threaded connection) and pressure rating.

Final rating depends on flange, material of construction, and O-ring selection.

Figure A-7. Max. Rating, Standard Tank Connections

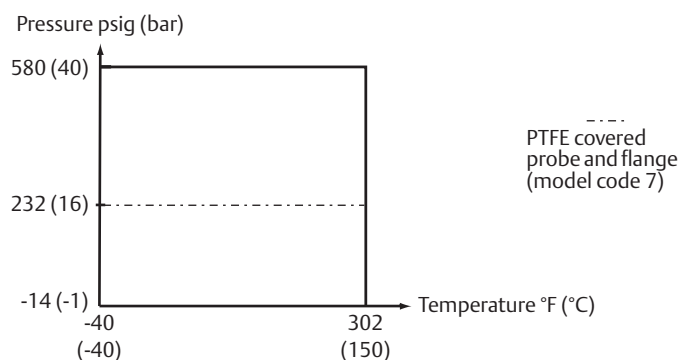

Table A-5. Temperature Ranges for Standard Tank Seals with Different O-ring Materials

O-ring material	Temperature °F (°C) in air	
	Minimum	Maximum
Viton® Fluoroelastomer	5 (-15)	302 (150)
Ethylene Propylene (EPDM)	-40 (-40)	266 (130)
Kalrez® 6375 Perfluoroelastomer	14 (-10)	302 (150)
Nitrile Butadiene (NBR)	-31 (-35)	230 (110)

Note

Always check the chemical compatibility of the O-ring material with your application. If the O-ring material is not compatible with its chemical environment, the O-ring may eventually malfunction.

A.2.6 Flange rating

ASME

316L SST flanges according to ASME B16.5 Table 2-2.3:

- Max. 302 °F/580 psig (150 °C/40 bar)

Alloy C-276 (UNS N10276) flanges according to ASME B16.5 Table 2-3.8:

- Max. 302 °F/580 psig (150 °C/40 bar)

Duplex 2205 (UNS S31803) flanges according to ASME B16.5 Table 2-2.8:

- Max. 302 °F/580 psig (150 °C/40 bar)

EN

EN 1.4404 according to EN 1092-1 material group 13E0:

- Max. 302 °F/580 psig (150 °C/40 bar)

Alloy C-276 (UNS N10276) flanges according to EN 1092-1 material group 12E0:

- Max. 302 °F/580 psig (150 °C/40 bar)

Duplex 2205 (EN 1.4462) flanges according to EN 1092-1 material group 16E0:

- Max. 580 psig (40 Bar), -22 °F (-30 °C) up to max 302 °F (150 °C)⁽¹⁾

JIS

316L SST Flanges according to JIS B2220 material group 2.3:

- Max. 302 °F/580 psig (150 °C/40 bar)

Fisher™ and Masoneilan™

316L SST Flanges according to ASME B16.5 Table 2-2.3:

- Max. 302 °F/580 psig (150 °C/40 bar)

Table A-6. Tri Clamp Rating

Size	Maximum pressure (bar) ⁽¹⁾
1½-in. (37.5 mm)	16
2-in. (50 mm)	16
3-in. (75 mm)	10
4-in. (100 mm)	10

1. The final rating depends on the clamp and gasket.

A.2.7 Plate design

Certain models of flanged alloy and PTFE covered probes have a tank connection design with a protective flange plate of the same material as the probe and with a backing flange in 316L/EN 1.4404. The protective flange plate prevents the backing flange from being exposed to the tank atmosphere.

Flange rating according to SST backing flange ASME B16.5 Table 2-2.3, EN 1092-1 material group 13E0, and JIS B2220 material group 2.3.

PTFE protective plate:

- Max. 302 °F/232 psig (150 °C/16 Bar)

1. Minimum temperature limit due to EN13445-2.

Alloy C-276 and Alloy 400 protective plate:

- Max. 302 °F/580 psig (150 °C/40 Bar)

A.2.8 Interface measurements

The Rosemount 3308 Series is well suited for interface measurements, including applications where the probe is fully submerged in the liquid.

Figure A-8. Interface Level Measurement

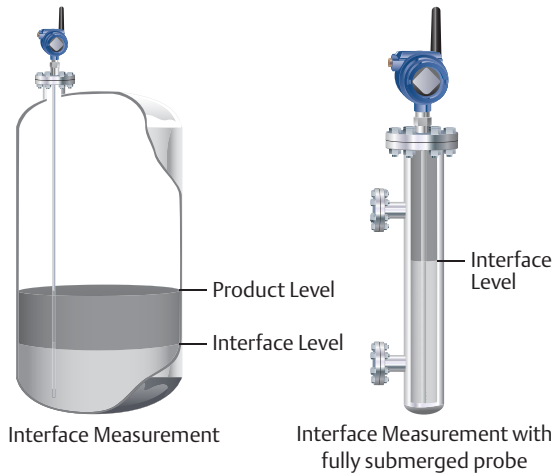

If interface is to be measured, follow these criteria:

- The dielectric constant of the upper product should be known and should not vary. The AMS Wireless Configurator and Field Communicator have a built-in Dielectric Constant Guide to assist users in determining the dielectric constant of the upper product.
- The dielectric constant of the upper product must have a lower dielectric constant than the lower product to have a distinct reflection.
- The difference between the dielectric constants for the two products must be larger than 10.
- Maximum dielectric constant for the upper product is 10 for the coaxial probe, and 5 for the single lead and flexible twin lead probes.
- Minimum detectable upper product thickness is 4 in. (10 cm) when the upper product is oil (DC=2.2) and the lower product is water (DC=80).

For guidelines on emulsion situations, consult your local Emerson™ representative.

For additional information, see the Guided Wave Radar Interface Measurement [Technical Note](#).

A.2.9 Conditions used for flange strength calculations

Table A-7. 316 SST or Process Connection with Strength Calculations

Standard	Bolting material	Gasket	Flange material	Hub material
ASME	Stainless steel SA193 B8M Class 2	Soft (1a) with min. thickness 1.6 mm	Stainless steel A182 Gr. F316L and EN 10222-5-1.4404	Stainless steel SA479M 316L and EN 10272-1.4404
EN, JIS	EN 1515-1/-2 group 13E0, A4-70	Soft (EN 1514-1) with min. thickness 1.6 mm		

Table A-8. Alloy C-276

Standard	Bolting material	Gasket	Flange material	Hub material
ASME	UNS N10276	Soft (1a) with min. thickness 1.6 mm	SB462 Gr. N10276 (solution annealed condition) or SB575 Gr. N10276 (solution annealed condition)	SB574 Gr. N10276
EN, JIS		Soft (EN 1514-1) with min. thickness 1.6 mm		

Table A-9. Duplex 2205

Standard	Bolting material	Gasket	Flange material	Hub material
ASME	A193 B7 or A320 L7	Soft (1a) with min. thickness 1.6 mm	Duplex stainless steel SA/A182 F51 and EN10222-5-1.4462 or SA/A240 Gr. S31803 and EN10028-7-1.4462	Stainless steel SA479M S31803 and EN, JIS Bumax 88 EN 10272-1.4462
EN, JIS	Bumax® 88	Soft (EN 1514-1) with min. thickness 1.6 mm		

A.3 Physical specifications

A.3.1 Material selection

Emerson provides a variety of Rosemount product with various product options and configurations including materials of construction that can be expected to perform well in a wide range of applications. The Rosemount product information presented is intended as a guide for the purchaser to make an appropriate selection for the application. It is the purchaser's sole responsibility to make a careful analysis of all process parameters (such as all chemical components, temperature, pressure, flow rate, abrasives, contaminants, etc.), when specifying product, materials, options and components for the particular application. Emerson is not in a position to evaluate or guarantee the compatibility of the process fluid or other process parameters with the product, options, configuration or materials of construction selected.

A.3.2 Tank connection

The tank connection consists of a tank seal, a flange, Tri Clamp, or NPT or BSPP (G) threads. See "Dimensional drawings" on page 139.

Certain models of flanged alloy and PTFE covered probes have a tank connection design with a protective plate of the same material as the probe (see Figure A-9). This is to prevent the 316L/EN 1.4404 SST flange from being exposed to the tank atmosphere.

Figure A-9. Probe and Protective Plate

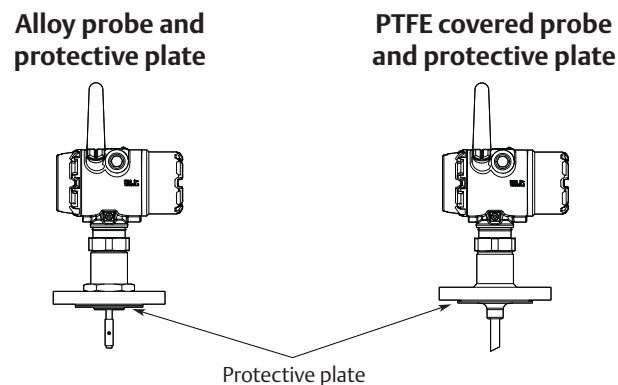

A.3.3 Housing and enclosure

Ingress protection

IP66/67 and NEMA® 4X

A.3.4 Flange dimensions

Follows ASME B16.5, JIS B2220, and EN 1092-1 standards for blind flanges. For Proprietary Fisher and Masoneilan flanges, see "Proprietary Flanges" on page 146.

A.3.5 Probes

Probe versions

Flexible single lead, rigid single lead, segmented rigid single lead, flexible twin lead, and coaxial.

Total probe length

This is defined from the Upper Reference Point to the end of the probe (weight included, if applicable).

Figure A-10. Total Probe Length

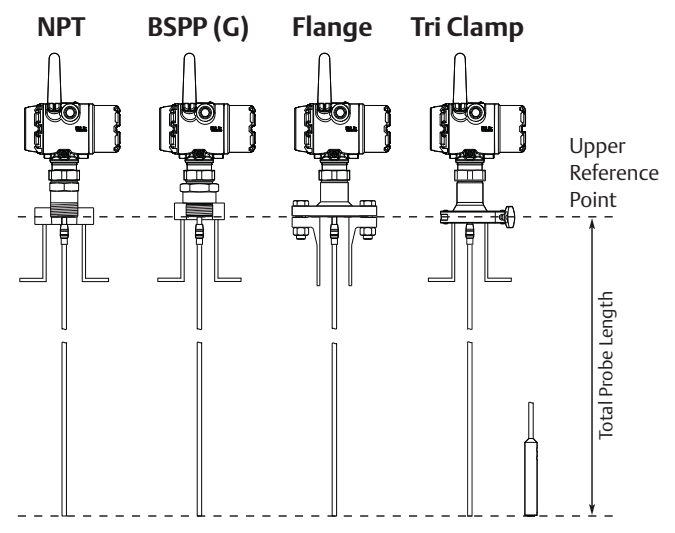

Select the probe length according to the required measuring range (the probe must be hung and fully extended through the entire distance where level readings are desired).

Cut-to-fit probes

All probes can be cut in field except for the PTFE covered probe.

However, there are some restrictions for the coaxial probe: Probes over 4.1 ft. (1.25 m) can be cut up to 2 ft. (0.6 m). Shorter probes can be cut to the minimum length of 1.3 ft. (0.4 m).

Table A-10. Minimum and Maximum Probe Length

Probe type	Probe length
Flexible single lead	3.3 to 55.8 ft. (1 to 17 m)
Rigid single lead (0.3-in./8 mm)	1.3 to 9.8 ft. (0.4 to 3 m)
Rigid single lead (0.5-in./13 mm)	1.3 to 19.7 ft. (0.4 to 6 m)
Segmented rigid single lead	1.3 to 32.8 ft. (0.4 to 10 m)
Flexible twin lead	3.3 to 55.8 ft. (1 to 17 m)
Coaxial	1.3 to 19.7 ft. (0.4 to 6 m)

Probe angle

0 to 90 degrees from vertical axis

Tensile strength

- Flexible single lead SST: 2698 lb (12 kN)
- Flexible single lead Alloy C-276: 1798 lb (8 kN)
- Flexible single lead Alloy 400: 1124 lb (5 kN)
- Flexible single lead Duplex 2205: 1349 lb (6 kN)
- Flexible twin lead: 2023 lb (9 kN)

Collapse load

- Flexible single lead SST: 3597 lb (16 kN)
- Flexible single lead Alloy C-276: 2023 lb (9 kN)
- Flexible single lead Alloy 400: 1349 lb (6 kN)
- Flexible single lead Duplex 2205: 1574 lb (7 kN)

Sideway capacity

- Rigid single lead/segmented rigid single lead:
4.4 ft. lbf, 0.44 lb at 9.8 ft. (6 Nm, 0.2 kg at 3 m)
- Coaxial: 73.7 ft. lbf, 3.7 lb at 19.7 ft. (100 Nm, 1.67 kg at 6 m)

A.3.6 Material exposed to tank atmosphere

Material of construction code	Material
1	316 SST ⁽¹⁾ , 316L SST (EN 1.4404), PTFE, PFA, and O-ring materials
2	Alloy C-276 (UNS N10276), PTFE, PFA, and O-ring materials
3	Alloy 400 (UNS N04400), PTFE, PFA, and O-ring materials
7	PTFE (1 mm PTFE cover)
8	PTFE, 316L SST (EN 1.4404), and O-ring materials
H	Alloy C-276 (UNS N10276), PTFE, PFA, and O-ring materials
D	Duplex 2205 (UNS S31803/EN 1.4462), Duplex 2507 (UNSS32750/EN 1.4410), PTFE, PFA, and O-ring materials

1. For flexible single/twin lead probes only.

A.3.7 Weight

Table A-11. Flange and Probes

Item	Weight
Flange	Depends on flange size
Flexible single lead probe	0.05 lb/ft (0.07 kg/m)
Rigid single lead probe (0.3-in./8 mm)	0.27 lb/ft (0.4 kg/m)
Rigid single lead probe (0.5-in./13 mm)	0.71 lb/ft (1.06 kg/m)
Segmented rigid single lead probe	0.71 lb/ft (1.06 kg/m)
Flexible twin lead probe	0.09 lb/ft (0.14 kg/m)
Coaxial probe	0.67 lb/ft (1 kg/m)

Table A-12. End Weight

Item	Weight
Small weight (code W1)	SST probe: 0.88 lb (0.40 kg)
	PTFE covered probe: 2.20 lb (1 kg)
Short weight (code W2)	0.88 lb (0.40 kg)
Heavy weight (code W3)	2.43 lb (1.10 kg)
Flexible twin lead probe	1.3 lb (0.60 kg)

A.3.8 End weight and anchoring options

There are in total four weight and anchoring options for flexible single lead probes. See [Figure A-11 on page 139](#) for dimensions.

Small weight (code W1)

A small weight is recommended for narrow tank openings less than 1.5 inches (38 mm). Required weight option for PTFE covered probes.

Short weight (code W2)

A short weight is available for the single flexible stainless steel probe. It is recommended for maximized measuring ranges with measurements close to the probe end.

Heavy weight (code W3)

A heavy weight is the recommended choice for most applications.

Chuck (code W4)

To tie probe end to tank bottom.

A.3.9 Engineered solutions

When standard model codes are not sufficient to fulfill requirements, please consult the factory to explore possible Engineered Solutions. This is typically, but not exclusively, related to the choice of wetted materials or the design of a process connection. These Engineered Solutions are part of the expanded offerings and may be subject to additional delivery lead time. For ordering, factory will supply a special P-labeled numeric option code that should be added at the end of the standard model string.

A.4 Ordering information

Specification and selection of product materials, options, or components must be made by the purchaser of the equipment. See [page 121](#) for more information on Material Selection.

Table A-13. Rosemount 3308 Series Level and/or Interface Measurements in Liquids Ordering Information

The starred offerings (★) represent the most common options and should be selected for best delivery. The non-starred offerings are subject to additional delivery lead time.

Model	Product description		
3308A	Guided Wave Radar Level Transmitter		★
Profile		Reference accuracy	
U	High Performance	±0.12 in. (±3 mm)	★
S	Standard	±0.2 in. (±5 mm)	★
Signal output (see page 116 for details)			
X	Wireless		★
Measurement type (see page 119)			
2	Level and Interface Transmitter		★
1	Level or Interface Transmitter (Interface available for fully submerged probe)		
Housing			
D1	Wireless Dual Compartment Housing, Aluminum (with plugged ½-14 NPT conduits)		★
E1	Wireless Dual Compartment Housing, Stainless steel (with plugged ½-14 NPT conduits)		★
Hazardous locations certifications (see Appendix B: Product Certifications)			
I1	ATEX Intrinsic Safety		★
I2	INMETRO Intrinsic Safety		★
I3	NEPSI Intrinsic Safety		★
I4	TIIS Intrinsic Safety		★
I5	FM Intrinsically Safe		★
I6	Canadian Intrinsically Safe		★
I7	IECEX Intrinsic Safety		★
IM	Technical Regulations Customs Union (EAC) Intrinsic Safety		★
KD	ATEX and Canadian Intrinsic Safety		
KE	FM and Canadian Intrinsically Safe		
KF	ATEX and FM Intrinsic Safety		
NA	No Hazardous Locations Certifications		
Operating temperature and pressure (see page 118)			
S	- 15 psig (-1bar) to 580 psig (40 bar) @ 302 °F (150 °C)		★

Table A-13. Rosemount 3308 Series Level and/or Interface Measurements in Liquids Ordering Information

The starred offerings (★) represent the most common options and should be selected for best delivery. The non-starred offerings are subject to additional delivery lead time.

Material of construction; process connection/probe		Probe type	
1	316L SST (EN 1.4404)	All	★
2	Alloy C-276 (UNS N10276). With plate design if flanged version.	3A, 3B, 4A, 4B, and 5A	
3	Alloy 400 (UNS N04400). With plate design if flanged version.	3A, 3B, 4A, 4B, and 5A	
7	PTFE covered probe and flange. With plate design.	4A and 5A	
8	PTFE covered probe	4A and 5A	
H	Alloy C-276 (UNS N10276) process connection, flange, and probe	3A, 3B, 4A, 4B, and 5A	
D	Duplex 2205 (UNS S31803) process connection, flange, and probe	4B and 5A	
Sealing O-ring material (see page 118)			
V	Viton Fluoroelastomer		★
E	Ethylene Propylene (EPDM)		★
K	Kalrez 6375 Perfluoroelastomer		★
B	Nitrile Butadiene (NBR)		★
Process connection size (see Table A-14 and Table A-15 on page 129 for availability)		Process connection type	
5	1½-in.	Thread/Tri Clamp	★
2	2-in./DN50/50A	NPT Thread/Flange/Tri Clamp	★
3	3-in./DN80/80A	Flange/Tri Clamp	★
4	4-in./DN100/100A	Flange/Tri Clamp	★
P	Proprietary Flanges	Proprietary Flange	★
1	1-in.	Thread	
6	6-in./DN150/150A	Flange	
8	8-in./DN200/200A	Flange	
Process connection rating (see Table A-14 and Table A-15 on page 129 for availability)			
NN	For use with non-flange process connection type		★
ASME rating			
AA	ASME B16.5 Class 150 Flange		★
AB	ASME B16.5 Class 300 Flange		★
EN rating			
DA	EN1092-1 PN16 Flange		★
DB	EN1092-1 PN40 Flange		★
JIS rating			
JA	JIS B2220 10K Flange		★
JB	JIS B2220 20K Flange		★
Proprietary			
PF	Proprietary Flange		★

Table A-13. Rosemount 3308 Series Level and/or Interface Measurements in Liquids Ordering Information

The starred offerings (★) represent the most common options and should be selected for best delivery. The non-starred offerings are subject to additional delivery lead time.

Process connection type (see Table A-14 and Table A-15 on page 129 for availability)			
Threads			
N	NPT thread		★
G	BSPP (G) thread		★
Flange faces			
F	Flat Face (FF) Flange, available for EN flanges		★
R	Raised Face (RF) Flange, available for ASME and JIS flanges		★
Proprietary flanges (see page 146 for dimensions)			
M	Masoneilan-Proprietary, 316 SST Torque Tube Flange, 316L		★
P	Fisher-Proprietary, 316 SST, (for 249B and 259B cages) Torque Tube Flange, 316L		★
Q	Fisher-Proprietary, 316 SST, (for 249C cages) Torque Tube Flange, 316L		★
Tri Clamp			
C	Tri Clamp		
Probe Type		Process connection type	Probe lengths
3B	Coaxial, perforated. For level and interface measurement.	Flange/1-, 1½-, 2-in. Thread	Min.: 1 ft. 4 in. (0.4 m) Max.: 19 ft. 8 in. (6 m)
4A	Rigid Single Lead (d=0.3"/8 mm)	Flange/1-, 1½-, 2-in. Thread/Tri Clamp	Min.: 1 ft. 4 in. (0.4 m) ⁽¹⁾ Max.: 9 ft. 10 in. (3 m)
4B	Rigid Single Lead (d=0.5"/13 mm)	Flange/1½-, 2-in. Thread/Tri Clamp	Min.: 1 ft. 4 in. (0.4 m) Max.: 19 ft. 8 in. (6 m)
5A	Flexible Single Lead (d=0.16"/4mm). Refer to page 127 to specify weight or chuck.	Flange/1-, 1½-, 2-in. Thread/Tri Clamp	Min.: 3 ft. 4 in. (1 m) ⁽¹⁾ Max.: 55 ft. 9 in. (17 m)
2A	Flexible Twin Lead with weight	Flange/1½-, 2-in. Thread	Min.: 3 ft. 4 in. (1 m) Max.: 55 ft. 9 in. (17 m)
3A ⁽²⁾	Coaxial (for level measurement)	Flange/1-, 1½-, 2-in. Thread	Min.: 1 ft. 4 in. (0.4 m) Max.: 19 ft. 8 in. (6 m)
4S	Segmented Rigid Single Lead (d=0.5"/13mm)	Flange/1½-, 2-in. Thread	Min.: 1 ft. 4 in. (0.4 m) Max.: 32 ft. 9 in. (10 m)
Probe length units (see page 121 for total probe length)			
E	English (feet, inches)		★
M	Metric (meters, centimeters)		★
Probe length (feet/meters)			
XXX	0-55 feet or 0-17 meters		★
Probe length (inches/centimeters)			
XX	0-11 inches or 0-99 Centimeters		★

Table A-13. Rosemount 3308 Series Level and/or Interface Measurements in Liquids Ordering Information

The starred offerings (★) represent the most common options and should be selected for best delivery. The non-starred offerings are subject to additional delivery lead time.

Update rate, operating frequency and protocol		
WA3	User Configurable Update Rate, 2.4 GHz DSSS (Direct Sequence Spread Spectrum), IEC 62591 (<i>WirelessHART</i>)	★
Omnidirectional wireless antenna and SmartPower™ solutions (see page 116 for functional specification)		
WK1	External Antenna, Adapter for Intrinsically Safe Black Power Module (Power Module Sold Separately)	★
WN1 ⁽³⁾	High Gain, Remote Antenna (see page 145 for dimensions), Adapter for Intrinsically Safe Black Power Module (Power Module Sold Separately)	★
	Note: Black Power Module must be shipped separately, order Model 701 PBKKF (part number 00753-9220-0001)	

Options (include with selected model number)

Display		
M5	LCD Display (see page 117)	★
Hydrostatic testing		
P1	Hydrostatic Testing, including certificate	★
Factory configuration		
C1	Factory Configuration per Configuration Data Sheet	★
Special quality assurance		
Q4	Calibration Data Certificate	★
Material traceability certification		
Q8 ⁽⁴⁾	Material Traceability Certification per EN 10204 3.1	★
Welding procedure qualification/specification		
Q66	Welding Procedure Qualification Record Documentation	
Q67	Welder Performance Qualification Record	
Q68	Welding Procedure Specification	
Special certifications		
QG	GOST Certification	
Material certification		
Q15 ⁽⁵⁾	NACE® material recommendation per NACE MR0175/ISO 15156	★
Installation options		
LS	Long Stud for Flexible Single Lead Probes, 25 cm (10 in.) (for use in tall nozzles)	★
BR	Mounting Bracket for 1½-in. NPT Process Connection (see page 144)	
Weight and anchoring options for flexible single probes (see page 123 for dimensions)		
W1	Small Weight (for narrow tank openings less than 2 in. (50 mm)) (Required for PTFE covered probes)	★
W3	Heavy Weight (for most applications)	★
W4	Chuck (to tie probe end to tank bottom)	★
W2	Short Weight (when measuring close to the probe end)	

Table A-13. Rosemount 3308 Series Level and/or Interface Measurements in Liquids Ordering Information

The starred offerings (★) represent the most common options and should be selected for best delivery. The non-starred offerings are subject to additional delivery lead time.

Weight assembly options for flexible single probes		
WU	Weight or chuck not mounted on the probe	★
Extended product warranty		
WR3	3-year limited warranty	★
WR5	5-year limited warranty	★
Plantweb™ diagnostic functionality		
DA1	HART® Diagnostics (see page 117)	★
Centering disc (see page 28 for dimensions and size recommendation)⁽⁶⁾		
S2 ⁽⁷⁾	2-in. Centering disc	★
S3 ⁽⁷⁾	3-in. Centering disc	★
S4 ⁽⁷⁾	4-in. Centering disc	★
P2	2-in. Centering disc PTFE	★
P3	3-in. Centering disc PTFE	★
P4	4-in. Centering disc PTFE	★
S6 ⁽⁷⁾	6-in. Centering disc	
S8 ⁽⁷⁾	8-in. Centering disc	
P6	6-in. Centering disc PTFE	
P8	8-in. Centering disc PTFE	
Assemble/consolidate to chamber (see page 20)		
XC	Consolidate to Chamber	★
Engineered solutions (see page 123)		
Pxxx	Engineered Solutions beyond standard model codes. (Consult factory for details)	

1. Minimum probe length is 4 ft. 11 in. (1.5 m) for PTFE covered probes (Material of Construction codes 7 and 8).
2. Requires model 3308Axx1.
3. Not CE approved.
4. Certificate includes all metallic pressure retaining wetted parts.
5. Available for Probe Type 3A, 3B, 4A, 4B, 4S, and PTFE-coated 5A.
6. Available for SST, Alloy C-276, Alloy 400, and Duplex 2205 probes, types 2A, 4A, 4B, 4S, and 5A. Not available with PTFE covered probes (Material of Construction codes 7 and 8).
7. Centering disc in same material as probe material of construction.

Table A-14. Availability of Process Connections - Material of Construction Codes 1, 2, 3, 7, and 8 (Type vs. Size and Rating)

Process connection size	Process connection rating							
	Thread/Tri Clamp	ASME B16.5 flanges		EN1092-1 flanges		JIS B2220 flanges		Proprietary flanges ⁽¹⁾
		Class 150	Class 300	PN16	PN40	10K	20K	
1-in.	G ⁽²⁾ , N ⁽²⁾	N/A	N/A	N/A	N/A	N/A	N/A	N/A
1½-in.	C ⁽²⁾ , N ⁽³⁾ , G ⁽³⁾	N/A	N/A	N/A	N/A	N/A	N/A	N/A
2-in./DN50/50A	C ⁽²⁾ , N ⁽²⁾	R	R	F	F	R	R	N/A
3-in./DN80/80A	C ⁽²⁾	R	R	F	F	R	R	N/A
4-in./DN100/100A	C ⁽²⁾	R	R	F	F	R	R	N/A
6-in./DN150/150A	N/A	R	R	F	F	R	R	N/A
8-in./DN200/200A	N/A	R	R	F	F	R	R	N/A
Proprietary flanges	N/A	N/A	N/A	N/A	N/A	N/A	N/A	M, P, Q

1. Only available with material of construction codes 1, 7, and 8.
2. Only available with material of construction codes 1 and 8.
3. Only available with material of construction codes 1, 2, 3, and 8.
 C = Tri Clamp (process connection type code C)
 F = Flat Face (process connection type code F)
 G = BSPP (G) thread (process connection type code G)
 M = Masoneilan (process connection type code M)
 N = NPT thread (process connection type code N)
 P = Fisher 249B/259B (process connection type code P)
 Q = Fisher 249C (process connection type code Q)
 R = Raised Face (process connection type code R)

Table A-15. Availability of Process Connections - Material of Construction Codes H and D (Type vs. Size and Rating)

Process connection size	Process connection rating							
	Thread/Tri Clamp	ASME B16.5 flanges		EN1092-1 flanges		JIS B2220 flanges		Proprietary flanges
		Class 150	Class 300	PN16	PN40	10K	20K	
1-in.	N/A	N/A	N/A	N/A	N/A	N/A	N/A	N/A
1½-in.	G, N	N/A	N/A	N/A	N/A	N/A	N/A	N/A
2-in./DN50/50A	N/A	R	R	N/A	N/A	N/A	N/A	N/A
3-in./DN80/80A	N/A	R	R	N/A	N/A	N/A	N/A	N/A
4-in./DN100/100A	N/A	R	R	N/A	N/A	N/A	N/A	N/A
6-in./DN150/150A	N/A	R ⁽¹⁾	N/A	N/A	N/A	N/A	N/A	N/A
8-in./DN200/200A	N/A	N/A	N/A	N/A	N/A	N/A	N/A	N/A
Proprietary flanges	N/A	N/A	N/A	N/A	N/A	N/A	N/A	N/A

1. Only available with material of construction code H.
 G = BSPP (G) thread (process connection type code G)
 N = NPT thread (process connection type code N)
 R = Raised Face (process connection type code R)

A.5 Spare parts and accessories

Table A-16. Rosemount 3308 Series Spare Parts List - Transmitter Head

Model	Product description	
3308A	Guided Wave Radar Level Transmitter	
Profile		Reference accuracy
U	High Performance	±0.12 in. (±3 mm)
S	Standard	±0.2 in. (±5 mm)
Signal output (see page 116 for details)		
X	Wireless	
Measurement type (see page 119)		
2	Level and Interface Transmitter	
1	Level or Interface Transmitter (Interface available for fully submerged probe)	
Housing		
D1	Wireless Dual Compartment Housing, Aluminum (with plugged ½-14 NPT conduits)	
E1	Wireless Dual Compartment Housing, Stainless steel (with plugged ½-14 NPT conduits)	
Product certifications (see Appendix B: Product Certifications)		
I1	ATEX Intrinsic Safety	
I2	INMETRO Intrinsic Safety	
I3	NEPSI Intrinsic Safety	
I4	TIIS Intrinsic Safety	
I5	FM Intrinsically Safe	
I6	Canadian Intrinsically Safe	
I7	IECEx Intrinsic Safety	
IM	Technical Regulations Customs Union (EAC) Intrinsic Safety	
KD	ATEX and Canadian Intrinsic Safety	
KE	FM and Canadian Intrinsically Safe	
KF	ATEX and FM Intrinsic Safety	
NA	No Hazardous Locations Certifications	
Operating temperature and pressure		
N	Not Applicable	
Material of construction; process connection / probe		
0	Not Applicable	
Sealing o-ring material		
N	Not Applicable	

Table A-16. Rosemount 3308 Series Spare Parts List - Transmitter Head

Process connection size	
N	Not Applicable
Process connection rating	
NN	Not Applicable
Process connection type	
0	Not Applicable
Probe Type	
0N	Not Applicable
Probe length units	
N	Not Applicable
Probe length (feet/meters)	
000	Not Applicable
Probe length (inches/centimeters)	
00	Not Applicable
Update rate, operating frequency and protocol	
WA3	User Configurable Update Rate, 2.4 GHz DSSS (Direct Sequence Spread Spectrum), IEC 62591 (<i>WirelessHART</i>)
Omnidirectional wireless antenna and SmartPower solutions (see page 116 for functional specification)	
WK1	External Antenna, Adapter for Intrinsically Safe Black Power Module (Power Module Sold Separately)
WN1 ⁽¹⁾	High Gain, Remote Antenna (see page 145 for dimensions), Adapter for Intrinsically Safe Black Power Module (Power Module Sold Separately)
	Note: Black Power Module must be shipped separately, order Model 701 PBKKF (part number 00753-9220-0001)

Options (include with selected model number)

Display	
M5	LCD Display (see page 117)
Factory configuration	
C1	Factory Configuration per Configuration Data Sheet
Special quality assurance	
Q4	Calibration Data Certificate
Special certifications	
QG	GOST Certification

Table A-16. Rosemount 3308 Series Spare Parts List - Transmitter Head

Extended product warranty	
WR3	3-year limited warranty
WR5	5-year limited warranty
Plantweb diagnostic Functionality	
DA1	HART Diagnostics (see page 117)
Engineered solutions (see page 123)	
Pxxx	Engineered Solutions beyond standard model codes. (Consult factory for details)

1. Not CE approved.

Table A-17. Rosemount 3308 Series Spare Parts List - Probe

Model	Product description	
3308A	Guided Wave Radar Level Transmitter	
Profile		Reference accuracy
U	High Performance	±0.12 in. (±3 mm)
S	Standard	±0.2 in. (±5 mm)
Signal output		
N	Not Applicable	
Measurement type		
9	Spare Process Seal and Probe	
Housing		
N0	Not Applicable	
Product certifications		
NA	Not Applicable	
Operating temperature and pressure (see page 118)		
S	- 15 psig (-1bar) to 580 psig (40 bar) @ 302 °F (150 °C)	
Material of construction; process connection / probe		Probe type
1	316L SST (EN 1.4404)	All
2	Alloy C-276 (UNS N10276). With plate design if flanged version.	3A, 3B, 4A, 4B, and 5A
3	Alloy 400 (UNS N04400). With plate design if flanged version.	3A, 3B, 4A, 4B, and 5A
7	PTFE covered probe and flange. With plate design.	4A and 5A
8	PTFE covered probe	4A and 5A
H	Alloy C-276 (UNS N10276) process connection, flange, and probe	3A, 3B, 4A, 4B, and 5A
D	Duplex 2205 (UNS S31803) process connection, flange, and probe	4B and 5A

Table A-17. Rosemount 3308 Series Spare Parts List - Probe

Sealing o-ring material (see Table A-5 on page 118)		
V	Viton Fluoroelastomer	
E	Ethylene Propylene (EPDM)	
K	Kalrez 6375 Perfluoroelastomer	
B	Nitrile Butadiene (NBR)	
Process connection size (see Table A-14 on page 129 for availability)	Process connection type	
5	1½-in.	Thread/Tri Clamp
2	2-in./DN50/50A	NPT Thread/Flange/Tri Clamp
3	3-in./DN80/80A	Flange/Tri Clamp
4	4-in./DN100/100A	Flange/Tri Clamp
P	Proprietary Flanges	Proprietary Flange
1	1-in.	Thread
6	6-in./DN150/150A	Flange
8	8-in./DN200/200A	Flange
Process connection rating (see Table A-14 on page 129 for availability)		
NN	For use with non-flange process connection type	
ASME rating		
AA	ASME B16.5 Class 150 Flange	
AB	ASME B16.5 Class 300 Flange	
EN rating		
DA	EN1092-1 PN16 Flange	
DB	EN1092-1 PN40 Flange	
JIS rating		
JA	JIS B2220 10K Flange	
JB	JIS B2220 20K Flange	
Proprietary		
PF	Proprietary Flange	
Process connection type (see Table A-14 on page 129 and Table A-15 on page 129 for availability)		
Threads		
N	NPT thread	
G	BSPP (G) thread	
Flange faces		
F	Flat Face (FF) Flange, available for EN flanges	
R	Raised Face (RF) Flange, available for ASME and JIS flanges	
Proprietary flanges (see page 146 for dimensions)		
M	Masoneilan-Proprietary, 316 SST Torque Tube Flange, 316L	

Table A-17. Rosemount 3308 Series Spare Parts List - Probe

P	Fisher-Proprietary, 316 SST, (for 249B and 259B cages) Torque Tube Flange, 316L		
Q	Fisher-Proprietary, 316 SST, (for 249C cages) Torque Tube Flange, 316L		
Tri Clamp			
C	Tri Clamp		
Probe Type		Process connection type	Probe lengths
3B	Coaxial, perforated. For level and interface measurement.	Flange/1-, 1½, 2-in. Thread	Min.: 1 ft. 4 in. (0.4 m) Max.: 19 ft. 8 in. (6 m)
4A	Rigid Single Lead (d=0.3"/8 mm)	Flange/1-, 1½, 2-in. Thread/Tri Clamp	Min.: 1 ft. 4 in. (0.4 m) ⁽¹⁾ Max.: 9 ft. 10 in. (3 m)
4B	Rigid Single Lead (d=0.5"/13 mm)	Flange/1½-, 2-in. Thread/Tri Clamp	Min.: 1 ft. 4 in. (0.4 m) Max.: 19 ft. 8 in. (6 m)
5A	Flexible Single Lead (d=0.16"/4mm). Refer to page 135 to specify weight or chuck.	Flange/1-, 1½-, 2-in. Thread/Tri Clamp	Min.: 3 ft. 4 in. (1 m) ⁽¹⁾ Max.: 55 ft. 9 in. (17 m)
2A	Flexible Twin Lead with weight	Flange/1½-, 2-in. Thread	Min.: 3 ft. 4 in. (1 m) Max.: 55 ft. 9 in. (17 m)
3A ⁽²⁾	Coaxial (for level measurement)	Flange/1-, 1½-, 2-in. Thread	Min.: 1 ft. 4 in. (0.4 m) Max.: 19 ft. 8 in. (6 m)
4S	Segmented Rigid Single Lead (d=0.5"/13mm)	Flange/1½-, 2-in. Thread	Min.: 1 ft. 4 in. (0.4 m) Max.: 32 ft. 9 in. (10 m)
Probe length units (see page 121 for total probe length)			
E	English (feet, inches)		
M	Metric (meters, centimeters)		
Probe length (feet/meters)			
XXX	0-55 feet or 0-17 meters		
Probe length (inches/centimeters)			
XX	0-11 inches or 0-99 Centimeters		

Options (include with selected model number)

Hydrostatic testing	
P1	Hydrostatic Testing, including certificate
Material traceability certification	
Q8 ⁽³⁾	Material Traceability Certification per EN 10204 3.1
Welding procedure qualification / specification	
Q66	Welding Procedure Qualification Record Documentation
Q67	Welder Performance Qualification Record
Q68	Welding Procedure Specification

Table A-17. Rosemount 3308 Series Spare Parts List - Probe

Installation options	
LS	Long Stud for Flexible Single Lead Probes, 25 cm (10 in.) (for use in tall nozzles)
BR	Mounting Bracket for 1½-in. NPT Process Connection (see page 144)
Weight and anchoring options for flexible single probes (see page 123 for dimensions)	
W1	Small Weight (for narrow tank openings less than 2 in. (50 mm)) (Required for PTFE covered probes)
W3	Heavy Weight (for most applications)
W4	Chuck (to tie probe end to tank bottom)
W2	Short Weight (when measuring close to the probe end)
Weight assembly options for flexible single probes	
WU	Weight or chuck not mounted on the probe
Extended product warranty	
WR3	3-year limited warranty
WR5	5-year limited warranty
Centering disc (see page 28 for dimensions and size recommendation)⁽⁴⁾	
S2 ⁽⁵⁾	2-in. Centering disc
S3 ⁽⁵⁾	3-in. Centering disc
S4 ⁽⁵⁾	4-in. Centering disc
P2	2-in. Centering disc PTFE
P3	3-in. Centering disc PTFE
P4	4-in. Centering disc PTFE
S6 ⁽⁵⁾	6-in. Centering disc
S8 ⁽⁵⁾	8-in. Centering disc
P6	6-in. Centering disc PTFE
P8	8-in. Centering disc PTFE
Assemble/consolidate to chamber (see page 20)	
XC	Consolidate to Chamber
Engineered solutions (see page 123)	
Pxxx	Engineered Solutions beyond standard model codes. (Consult factory for details)

1. Minimum probe length is 4 ft. 11 in. (1.5 m) for PTFE covered probes (Material of Construction codes 7 and 8).
2. Requires model 3308Axx1.
3. Certificate includes all metallic pressure retaining wetted parts.
4. Available for probe types 2A, 4A, 4B, and 5A. Not available with PTFE covered probes (Material of Construction codes 7 and 8).
5. Centering disc in same material as probe material of construction.

Table A-18. Accessories Ordering Information

The starred offerings (★) represent the most common options and should be selected for best delivery. The non-starred offerings are subject to additional delivery lead time.

Centering discs for rigid single lead probe (d=0.3"/8 mm) ⁽¹⁾⁽²⁾		Outer diameter	
03300-1655-0001	Kit, 2-in. Centering Disc, SST	1.8 in. (45 mm)	★
03300-1655-0006	Kit, 2-in. Centering Disc, PTFE	1.8 in. (45 mm)	★
03300-1655-0002	Kit, 3-in. Centering Disc, SST	2.7 in. (68 mm)	★
03300-1655-0007	Kit, 3-in. Centering Disc, PTFE	2.7 in. (68 mm)	★
03300-1655-0003	Kit, 4-in. Centering Disc, SST	3.6 in. (92 mm)	★
03300-1655-0008	Kit, 4-in. Centering Disc, PTFE	3.6 in. (92 mm)	★
03300-1655-0004	Kit, 6-in. Centering Disc, SST	5.55 in. (141 mm)	
03300-1655-0009	Kit, 6-in. Centering Disc, PTFE	5.55 in. (141 mm)	
03300-1655-0005	Kit, 8-in. Centering Disc, SST	7.40 in. (188 mm)	
03300-1655-0010	Kit, 8-in. Centering Disc, PTFE	7.40 in. (188 mm)	
Centering discs for rigid single lead probe (d=0.5"/13 mm) ⁽¹⁾⁽²⁾		Outer diameter	
03300-1655-0301	Kit, 2-in. Centering Disc, SST	1.8 in. (45 mm)	★
03300-1655-0306	Kit, 2-in. Centering Disc, PTFE	1.8 in. (45 mm)	★
03300-1655-0302	Kit, 3-in. Centering Disc, SST	2.7 in. (68 mm)	★
03300-1655-0307	Kit, 3-in. Centering Disc, PTFE	2.7 in. (68 mm)	★
03300-1655-0303	Kit, 4-in. Centering Disc, SST	3.6 in. (92 mm)	★
03300-1655-0308	Kit, 4-in. Centering Disc, PTFE	3.6 in. (92 mm)	★
03300-1655-0304	Kit, 6-in. Centering Disc, SST	5.55 in. (141 mm)	
03300-1655-0309	Kit, 6-in. Centering Disc, PTFE	5.55 in. (141 mm)	
03300-1655-0305	Kit, 8-in. Centering Disc, SST	7.40 in. (188 mm)	
03300-1655-0310	Kit, 8-in. Centering Disc, PTFE	7.40 in. (188 mm)	
Centering discs for flexible single/twin lead probes ⁽¹⁾⁽²⁾		Outer diameter	
03300-1655-1001	Kit, 2-in. Centering disc, SST	1.8 in. (45 mm)	★
03300-1655-1006	Kit, 2-in. Centering disc, PTFE	1.8 in. (45 mm)	★
03300-1655-1002	Kit, 3-in. Centering disc, SST	2.7 in. (68 mm)	★
03300-1655-1007	Kit, 3-in. Centering disc, PTFE	2.7 in. (68 mm)	★
03300-1655-1003	Kit, 4-in. Centering disc, SST	3.6 in. (92 mm)	★
03300-1655-1008	Kit, 4-in. Centering disc, PTFE	3.6 in. (92 mm)	★
03300-1655-1004	Kit, 6-in. Centering disc, SST	5.55 in. (141 mm)	
03300-1655-1009	Kit, 6-in. Centering disc, PTFE	5.55 in. (141 mm)	
03300-1655-1005	Kit, 8-in. Centering disc, SST,	7.40 in. (188 mm)	
03300-1655-1010	Kit, 8-in. Centering disc, PTFE	7.40 in. (188 mm)	

Table A-18. Accessories Ordering Information

The starred offerings (★) represent the most common options and should be selected for best delivery. The non-starred offerings are subject to additional delivery lead time.

Centering discs for mounting between segments (probe type 4S only)		Outer diameter	
03300-1656-1002	2-in. Centering Disc (1 pc), PTFE, Segmented Rigid Single Lead	1.8 in. (45 mm)	
03300-1656-1003	3-in. Centering Disc (1 pc), PTFE, Segmented Rigid Single Lead	2.7 in. (68 mm)	
03300-1656-1004	4-in. Centering Disc (1 pc), PTFE, Segmented Rigid Single Lead	3.6 in. (92 mm)	
03300-1656-1006	6-in. Centering Disc (1 pc), PTFE, Segmented Rigid Single Lead	5.55 in. (141 mm)	
03300-1656-1008	8-in. Centering Disc (1 pc), PTFE, Segmented Rigid Single Lead	7.40 in. (188 mm)	
03300-1656-3002	2-in. Centering Disc (3 pcs), PTFE, Segmented Rigid Single Lead	1.8 in. (45 mm)	
03300-1656-3003	3-in. Centering Disc (3 pcs), PTFE, Segmented Rigid Single Lead	2.7 in. (68 mm)	
03300-1656-3004	4-in. Centering Disc (3 pcs), PTFE, Segmented Rigid Single Lead	3.6 in. (92 mm)	
03300-1656-3006	6-in. Centering Disc (3 pcs), PTFE, Segmented Rigid Single Lead	5.55 in. (141 mm)	
03300-1656-3008	8-in. Centering Disc (3 pcs), PTFE, Segmented Rigid Single Lead	7.40 in. (188 mm)	
03300-1656-5002	2-in. Centering Disc (5 pcs), PTFE, Segmented Rigid Single Lead	1.8 in. (45 mm)	
03300-1656-5003	3-in. Centering Disc (5 pcs), PTFE, Segmented Rigid Single Lead	2.7 in. (68 mm)	
03300-1656-5004	4-in. Centering Disc (5 pcs), PTFE, Segmented Rigid Single Lead	3.6 in. (92 mm)	
03300-1656-5006	6-in. Centering Disc (5 pcs), PTFE, Segmented Rigid Single Lead	5.55 in. (141 mm)	
03300-1656-5008	8-in. Centering Disc (5 pcs), PTFE, Segmented Rigid Single Lead	7.40 in. (188 mm)	
Segmented rigid single lead probe spare part kit			
03300-0050-0001	15.2-in./385 mm Segment for Top connection (1 pc)		
03300-0050-0002	31.5-in./800 mm Segment (1 pc)		
03300-0050-0003	31.5-in./800 mm Segment (3 pcs)		
03300-0050-0004	31.5-in./800 mm Segment (5 pcs)		
03300-0050-0005	31.5-in./800 mm Segment (12 pcs)		
Vented flanges⁽³⁾			
03300-1812-0092	Fisher 249B/259B ⁽⁴⁾		
03300-1812-0093	Fisher 249C		
03300-1812-0091	Masoneilan		
Flushing connection rings			
DP0002-2111-S6	2-in. ANSI, ¼-in. NPT connection		
DP0002-3111-S6	3-in. ANSI, ¼-in. NPT connection		
DP0002-4111-S6	4-in. ANSI, ¼-in. NPT connection		
DP0002-5111-S6	DN50, ¼-in. NPT. connection		
DP0002-8111-S6	DN80, ¼-in. NPT. connection		

Table A-18. Accessories Ordering Information

The starred offerings (★) represent the most common options and should be selected for best delivery. The non-starred offerings are subject to additional delivery lead time.

Other		
03300-7004-0001	MACTek® VIATOR® HART Modem and cables (RS232 connection)	★
03300-7004-0002	MACTek VIATOR HART Modem and cables (USB connection)	★

1. If a centering disc is required for a flanged probe, the centering disc can be ordered with options Sx or Px on [page 128](#) in the model code. If a centering disc is required for a threaded connection or as a spare part, it should be ordered using the item numbers listed in this table. Refer to [Table 3-5](#) for centering disc size recommendation for different pipe schedules.
2. To order a centering disc in a different material, consult the factory.
3. 1½-in. NPT threaded connection is required.
4. For pressure and temperature rating, see “Fisher™ and Masoneilan™” on [page 118](#).

A.6 Dimensional drawings

Figure A-11. Flexible Single Lead Probe

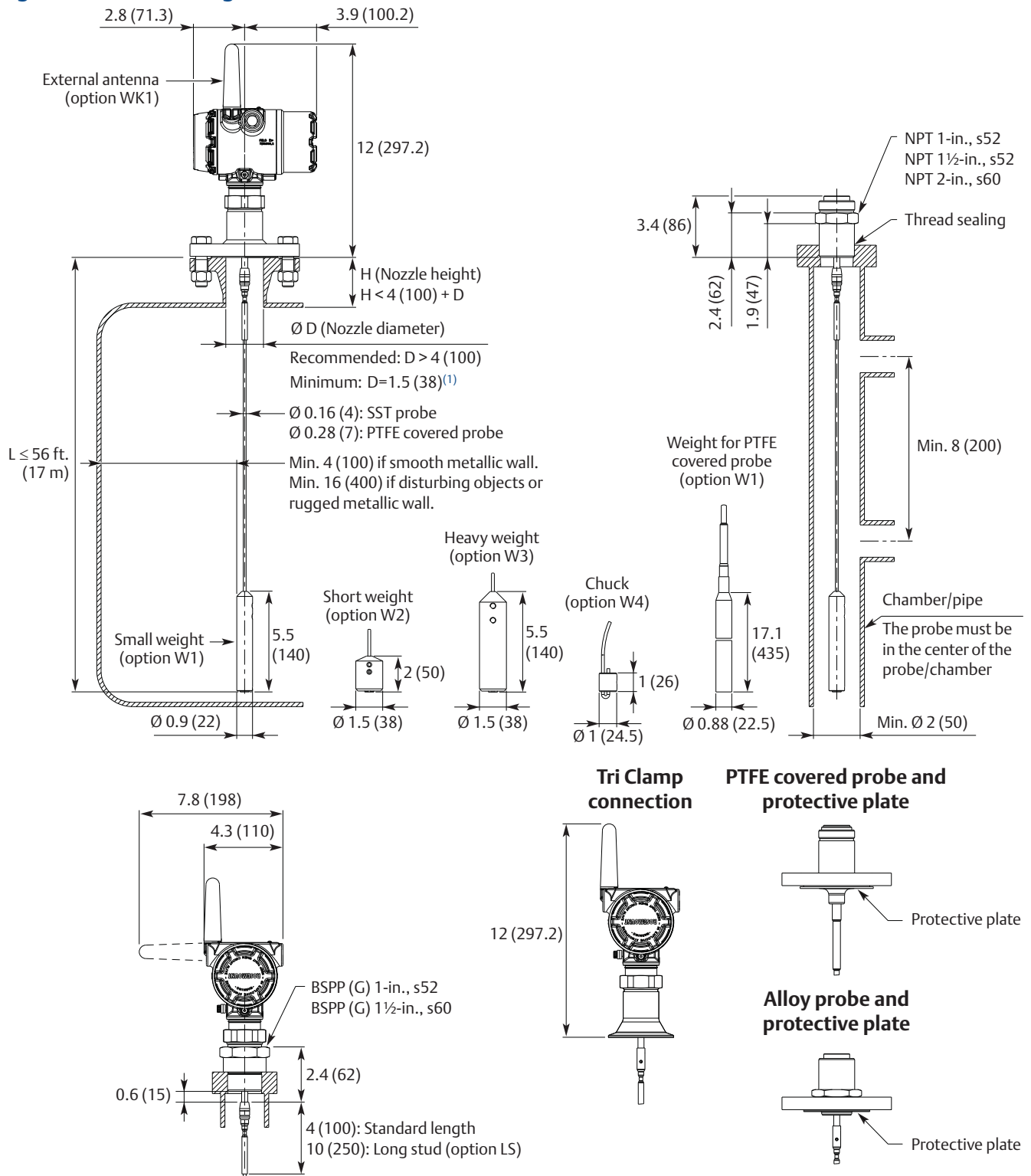

1. The Trim Near Zone (TNZ) function may be necessary or an Upper Null Zone (UNZ) setup may be required to mask the nozzle. Dimensions are in inches (millimeters).

Figure A-12. Rigid Single Lead Probe

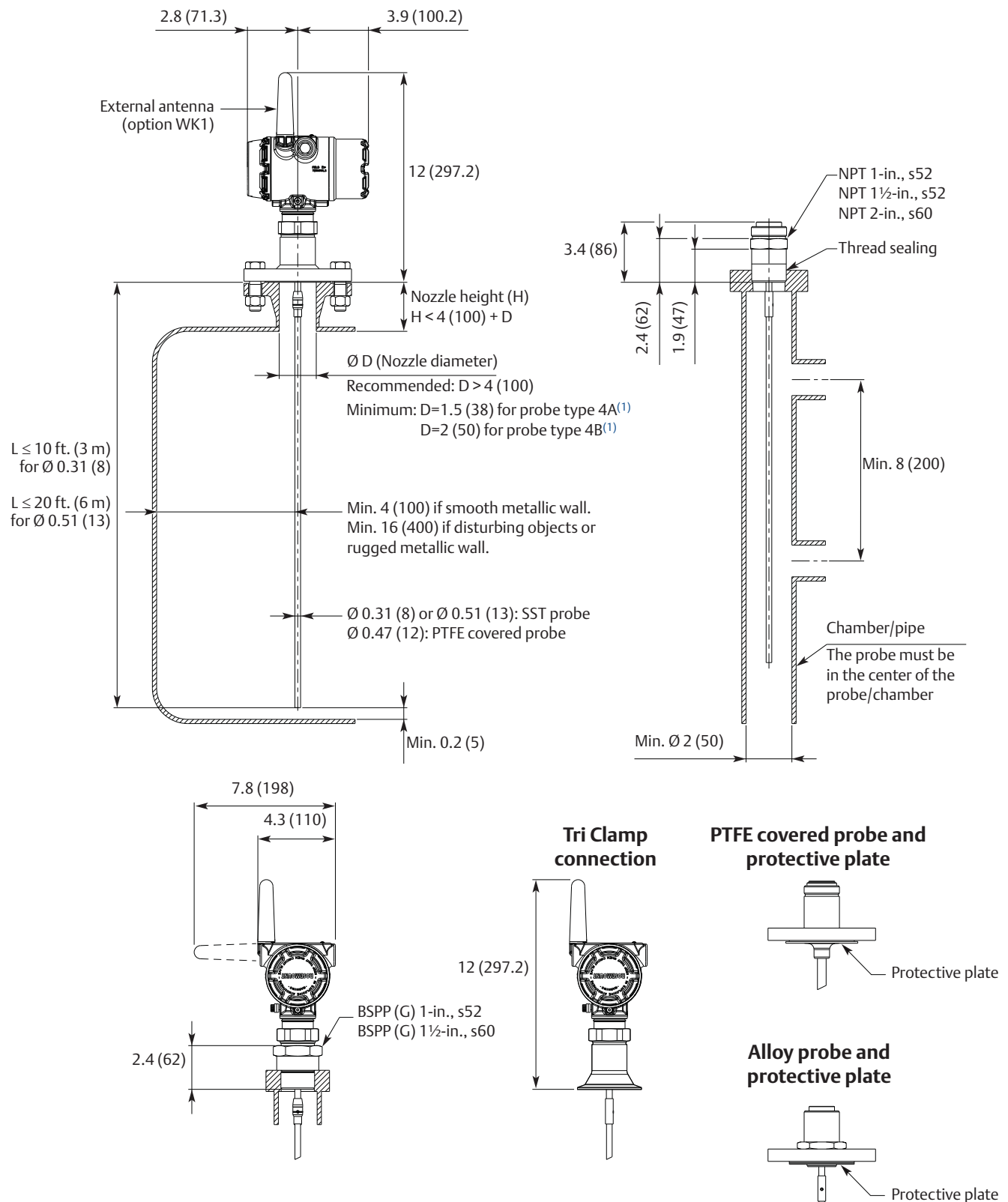

1. The Trim Near Zone (TNZ) function may be necessary or an Upper Null Zone (UNZ) setup may be required to mask the nozzle.
Dimensions are in inches (millimeters).

Figure A-13. Segmented Rigid Single Lead Probe

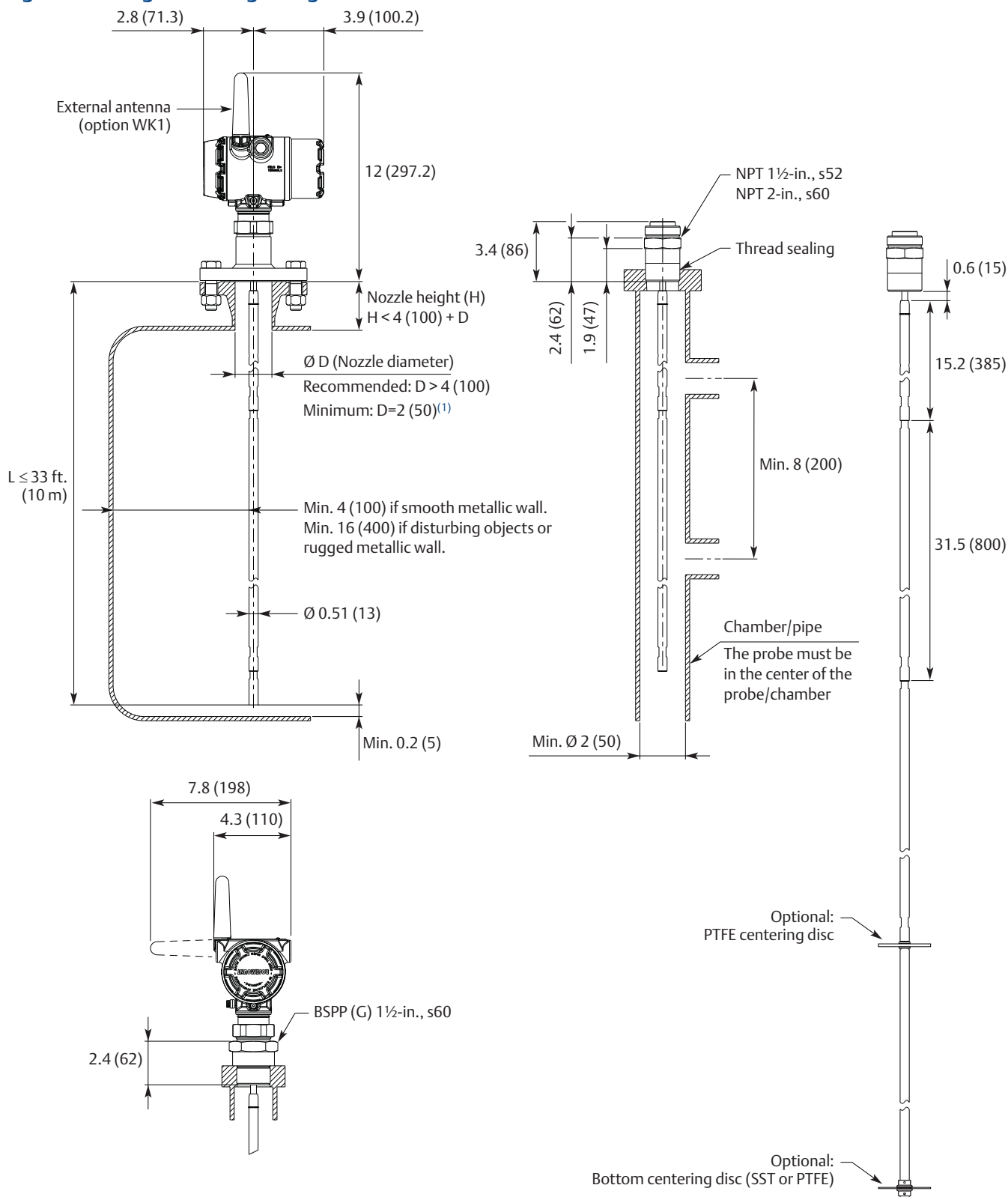

1. The Trim Near Zone (TNZ) function may be necessary or an Upper Null Zone (UNZ) setup may be required to mask the nozzle. Dimensions are in inches (millimeters).

Figure A-14. Coaxial Probe

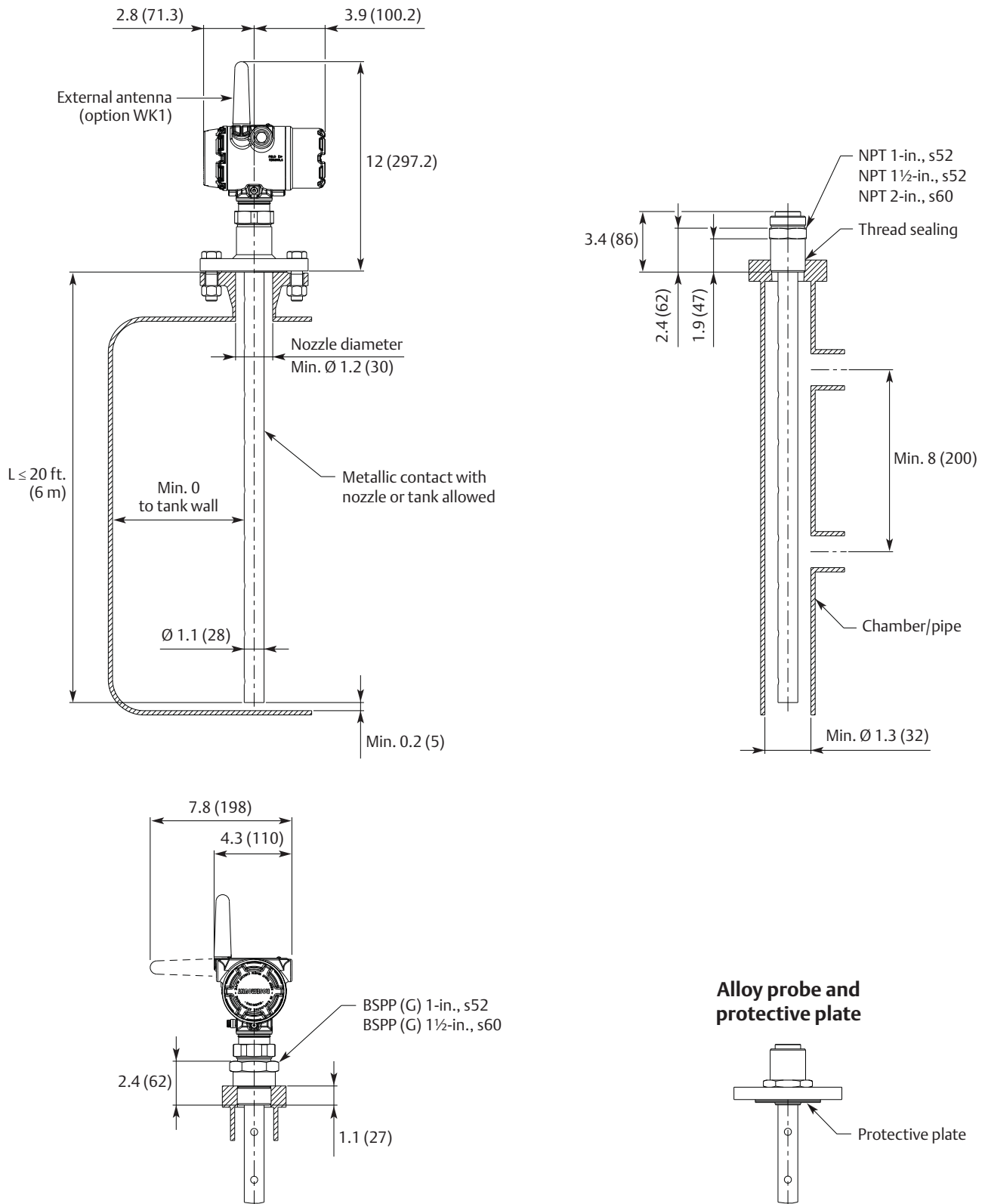

Dimensions are in inches (millimeters).

Figure A-15. Flexible Twin Lead Probe

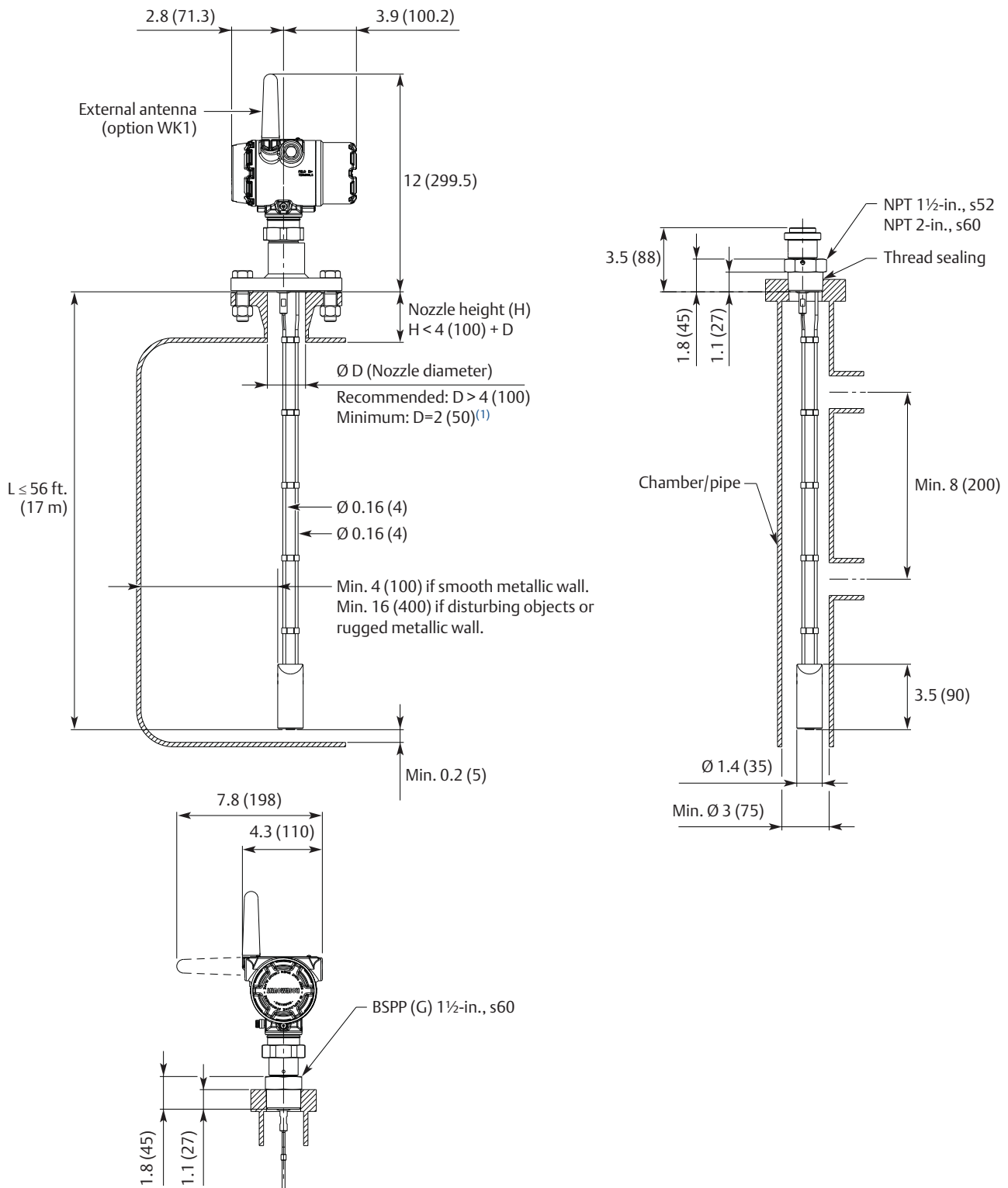

1. The Trim Near Zone (TNZ) function may be necessary or an Upper Null Zone (UNZ) setup may be required to mask the nozzle. Dimensions are in inches (millimeters).

Figure A-16. Mounting Bracket (Option Code BR)

Pipe mounting
(vertical pipe)

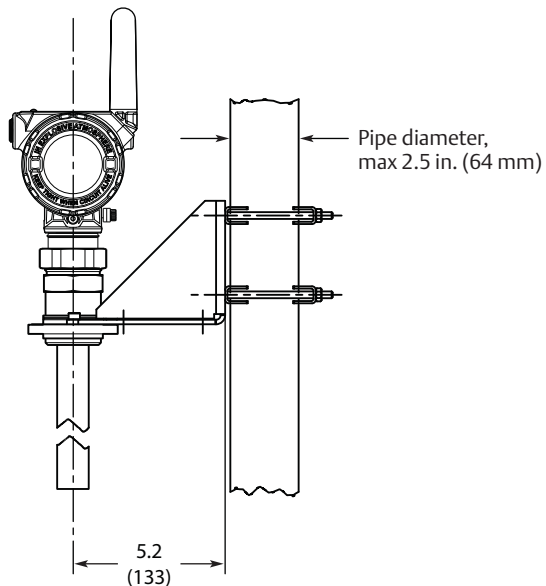

Pipe mounting
(horizontal pipe)

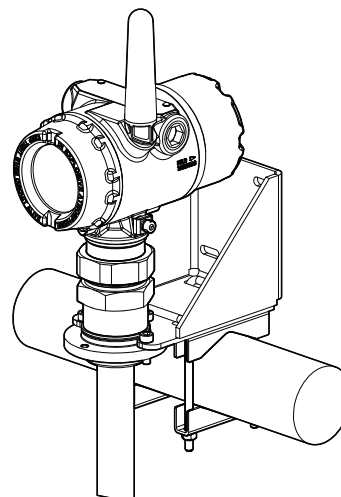

Wall mounting

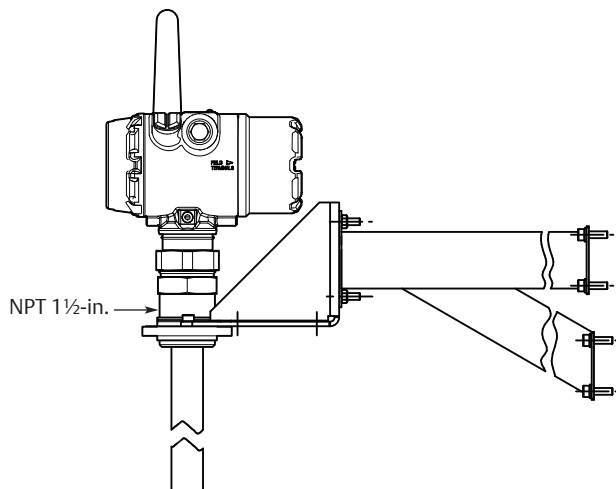

Hole pattern for wall mounting

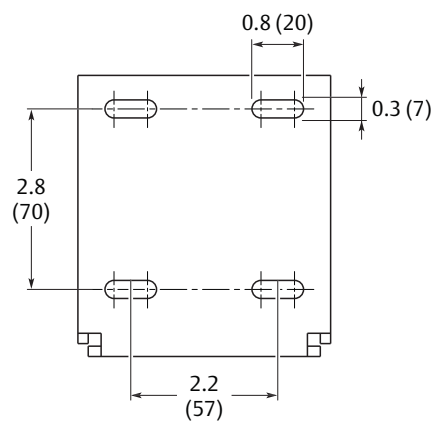

Dimensions are in inches (millimeters).

Figure A-17. High Gain, Remote Antenna (Option Code WN1)

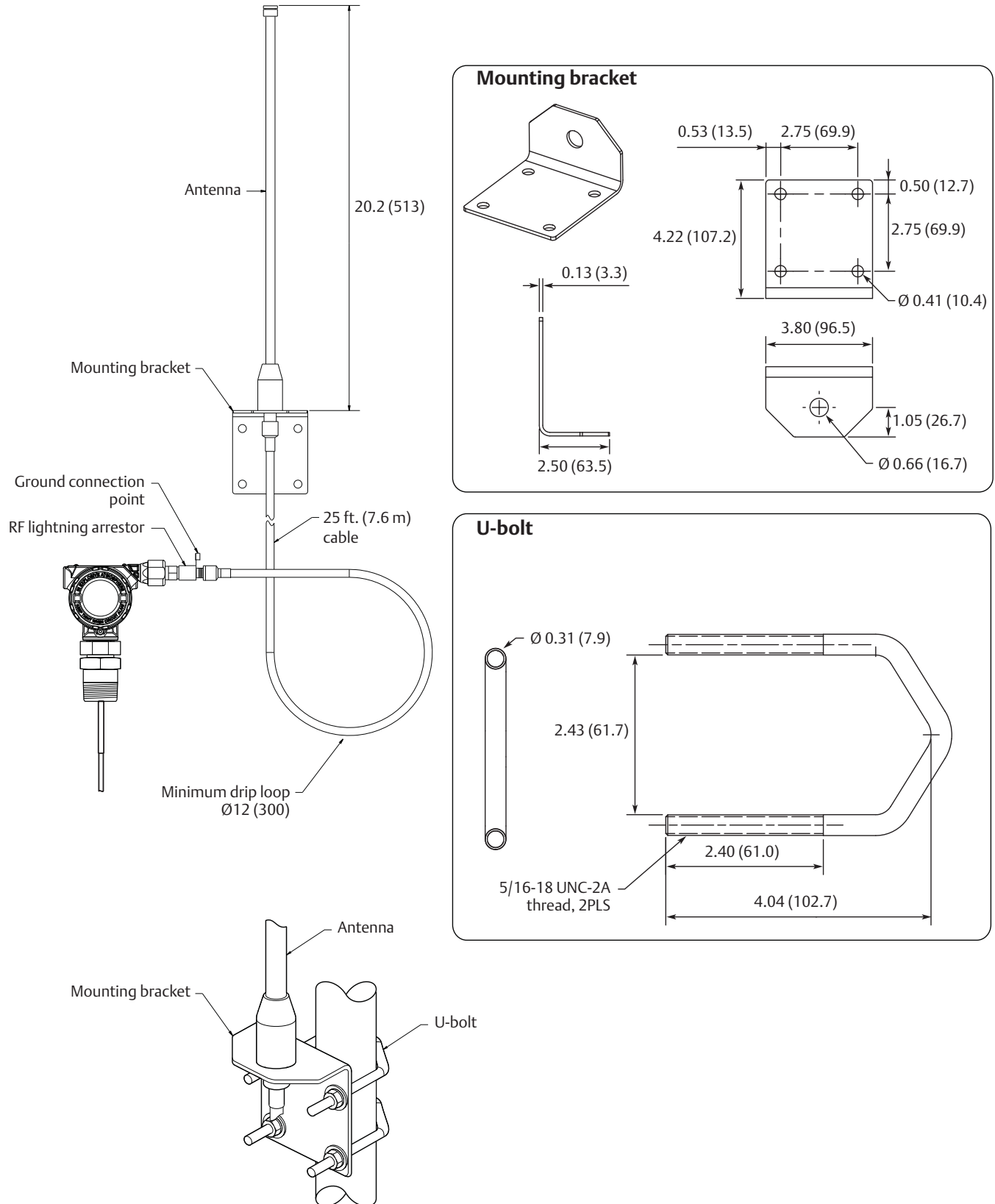

Dimensions are in inches (millimeters).

Figure A-18. Proprietary Flanges

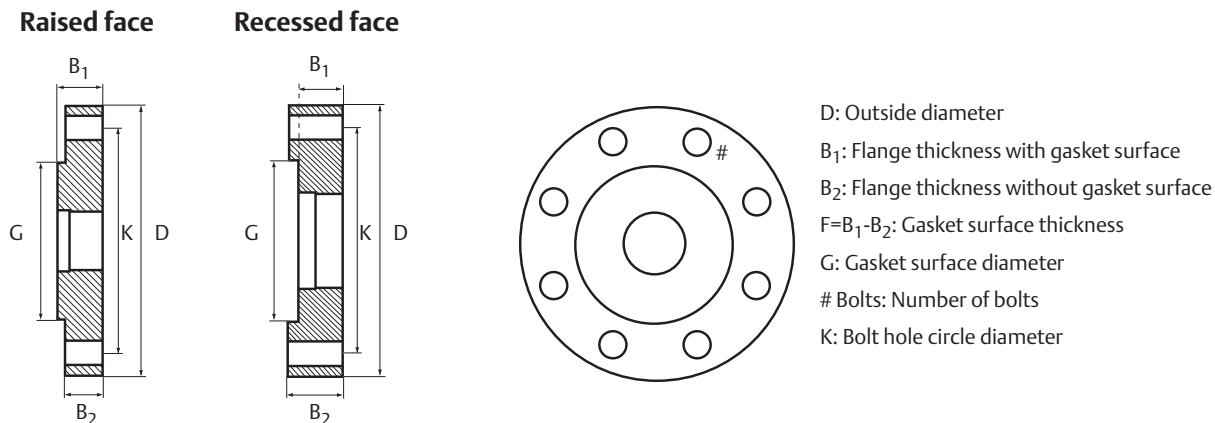

Dimensions are in inches (millimeters).

Note

Dimensions may be used to aid in the identification of installed flanges. It is not intended for manufacturing use.

Table A-19. Dimensions of Proprietary Flanges

Special flanges ⁽¹⁾	D	B_1	B_2	F	G	# Bolts	K
Fisher 249B/259B ⁽²⁾	9.00 (228.6)	1.50 (38.2)	1.25 (31.8)	0.25 (6.4)	5.23 (132.8)	8	7.25 (184.2)
Fisher 249C ⁽³⁾	5.69 (144.5)	0.94 (23.8)	1.13 (28.6)	-0.19 (-4.8)	3.37 (85.7)	8	4.75 (120.65)
Masoneilan ⁽²⁾	7.51 (191.0)	1.54 (39.0)	1.30 (33.0)	0.24 (6.0)	4.02 (102.0)	8	5.87 (149.0)

1. These flanges are also available in a vented version.
2. Flange with raised face.
3. Flange with recessed face.

Appendix B Product Certifications

Safety messages	page 147
European Union directive information	page 148
Telecommunication compliance	page 148
FCC and IC	page 148
Ordinary location certification for FM approvals	page 148
Hazardous locations certificates	page 148
Other certifications	page 150
Approval drawings	page 150

B.1 Safety messages

Procedures and instructions in this section may require special precautions to ensure the safety of the personnel performing the operations. Information that raises potential safety issues is indicated by a warning symbol () . Refer to the following safety messages before performing an operation preceded by this symbol.

WARNING

Failure to follow safe installation and servicing guidelines could result in death or serious injury.

- Make sure the transmitter is installed by qualified personnel and in accordance with applicable code of practice.
- Use the equipment only as specified in this manual. Failure to do so may impair the protection provided by the equipment.

Explosions could result in death or serious injury.

- Verify that the operating environment of the gauge is consistent with the appropriate hazardous locations certifications.
- Installation of device in an explosive environment must be in accordance with appropriate local, national and international standards, codes, and practices.
- Ensure device is installed in accordance with intrinsically safe or non-incendive field practices.

Electrical shock can result in death or serious injury.

- Ground device on non-metallic tanks (e.g. fiberglass tanks) to prevent electrostatic charge build-up.
- Single lead probes are sensitive for strong electromagnetic fields and therefore not suitable for non-metallic tanks.
- Care must be taken during transportation of power module to prevent electrostatic charge build-up.
- Device must be installed to ensure a minimum antenna separation distance of 8 in. (20 cm) from all persons.
- Probes covered with plastic and/or with plastic discs may generate an ignition-capable level of electrostatic charge under certain extreme conditions. Therefore, when the probe is used in a potentially explosive atmosphere, appropriate measures must be taken to prevent electrostatic discharge.

Process leaks could result in death or serious injury.

- Handle the transmitter carefully.
- If the process seal is damaged, gas could escape from the tank when removing the transmitter head from the probe.
- Only qualified personnel should install the equipment.

B.2 European Union directive information

The EU Declaration of Conformity for all applicable European directives for this product can be found in the 3308A [Product Certifications](#) document. The most current revision is available at Emerson.com/Rosemount.

B.3 Telecommunication compliance

All wireless devices require certification to ensure that they adhere to regulations regarding the use of the RF spectrum. Nearly every country requires this type of product certification. Emerson™ is working with governmental agencies around the world to supply fully compliant products and remove the risk of violating country directives or laws governing wireless device usage.

B.4 FCC and IC

This device complies with Part 15 of the FCC Rules. Operation is subject to the following conditions: This device may not cause harmful interference and this device must accept any interference, including any interference that may cause undesired operation of the device. This device must be installed to ensure a minimum antenna separation distance of 20 cm from all persons.

This radio transmitter (IC: 2931A-330858) has been approved by Industry Canada to operate with the antenna types listed below with the maximum permissible gain indicated. Antenna types not included in this list, having a gain greater than the maximum gain indicated for that type, are strictly prohibited for use with this device.

Antenna model option	Antenna type	Max gain (dBi)	Status
WK1	Integral Omni-directional	2	Available
WM1	Integral Omni-directional	4.5	Available
WN1	Remote Omni-directional	8	Available
WS1	Remote Yagi	12	Future
WT1	Remote Sector	17	Future
WV1	Remote Parabolic	24	Future

This device complies with Industry Canada license-exempt RSS standard(s). Operation is subject to the following two conditions: (1) This device may not cause interference, and (2) this device must accept any interference, including any interference that may cause undesired operation of the device.

⚠ CAUTION

Changes or modifications to the equipment not expressly approved by Emerson could void the user's authority to operate the equipment.

Cet appareil est conforme à la norme RSS Industrie Canada exempt de licence. Son fonctionnement est soumis aux deux conditions suivantes: (1) cet appareil ne doit pas provoquer d'interférences et (2) cet appareil doit accepter toute interférence, y compris les interférences pouvant causer un mauvais fonctionnement du dispositif.

⚠ CAUTION

Les changements ou les modifications apportés à l'équipement qui n'est pas expressément approuvé par Emerson pourraient annuler l'autorité de l'utilisateur à utiliser cet équipement.

B.5 Ordinary location certification for FM approvals

As standard, the transmitter has been examined and tested to determine that the design meets basic electrical, mechanical, and fire protection requirements by FM Approvals, a nationally recognized testing laboratory (NRTL) as accredited by the Federal Occupational Safety and Health Administration (OSHA).

B.6 Hazardous locations certificates

B.6.1 U.S.A.

I5 U.S.A Intrinsically Safe

Certificate: FM17US0014X

Standards: FM Class 3600 – 2011, FM Class 3610 – 2015, FM Class 3810 – 2005, NEMA® 250 – 2003, ANSI/ISA 60079-0:2013, ANSI/UL 60079-11:2014, ANSI/ISA 60529:2004, ANSI/ISA 61010-1:2004

Markings: IS CL I, DIV 1, GP A, B, C, D:
IS CL I Zone 0, AEx ia IIC T4 Ga;
T4 Ta = -55 to +70 °C
Type 4X; IP66; IP67
WHEN INSTALLED PER ROSEMOUNT DRAWING 03308-1010 (See [Figure B-1 on page 151](#))

Special Conditions of Certification:

1. The Model 3308 transmitter housing contains aluminum; protect the enclosure to avoid a potential risk of ignition due to impact or friction.
2. The surface resistivity of the polymeric antenna is greater than $1G\Omega$. To avoid electrostatic charge buildup, it must not be rubbed or cleaned with solvents or a dry cloth.
3. For use only with the Emerson Process Management Model 701PBKFF SmartPower™ Option or the Computational Systems, Inc Model MHM-89004 battery module.
4. Only the Emerson Process Management 375 or 475 Field Communicator is approved for use with this transmitter.
5. The maximum permitted operating temperature of the Rosemount 3308A transmitter is 70 °C. To avoid the effects of process temperature and other thermal effects care shall be taken to ensure that the “Electronics Temperature” does not exceed 70 °C.

B.6.2 Canada**16** Canada Intrinsically Safe

Certificate: FM17CA0007X

Standards: CSA Std. C22.2 No. 61010-1:2004, CSA Std. 22.2 No. 94-M91, CAN/CSA-C22.2 NO. 60079-0:15, CAN/CSA-C22.2 NO. 60079-11:14, C22.2 No. 60529:2016

Markings: INTRINSICALLY SAFE Ex ia
CLASS I, GP A, B, C, D;
CLASS I, Zone 0, Ex ia IIC T4 Ga;
TEMP CODE T4 (-55 °C ≤ Ta ≤ +70 °C)
Type 4X; IP66; IP67
WHEN INSTALLED PER ROSEMOUNT DRAWING
03308-1010. (See Figure B-1 on page 151)**Special Conditions of Certification:**

1. The Model 3308 transmitter housing contains aluminum; protect the enclosure to avoid a potential risk of ignition due to impact or friction.
2. The surface resistivity of the polymeric antenna is greater than $1G\Omega$. To avoid electrostatic charge buildup, it must not be rubbed or cleaned with solvents or a dry cloth.
3. For use with the Emerson Process Management 701PBKFF SmartPower Option or the Computational Systems, Inc Model MHM-89004 battery module only.
4. Only the Emerson Process Management 375 or 475 Field Communicator is approved for use with this transmitter.
5. The maximum permitted operating temperature of the Rosemount 3308A transmitter is 70 °C. To avoid the effects of process temperature and other thermal effects care shall be taken to ensure that the “Electronics Temperature” does not exceed 70 °C.

B.6.3 Europe**11** ATEX Intrinsic Safe

Certificate: FM 12ATEX0072X

Standards: EN 60079-0:2012+A11:2013, EN 60079-11:2012; EN 60529:1991+A2:2013

Markings:  Category II 1 G, Ex ia IIC T4 Ga
(-55 °C ≤ Ta ≤ +70 °C); 1180
 2460**Special Conditions of Certification:**

1. The Model 3308 transmitter housing contains aluminum; protect the enclosure to avoid a potential risk of ignition due to impact or friction.
2. The surface resistivity of the polymeric antenna is greater than $1G\Omega$. To avoid electrostatic charge buildup, it must not be rubbed or cleaned with solvents or a dry cloth.
3. For use only with the ATEX certified (Baseefa11ATEX0042X) Emerson Process Management Model 701PBKFF SmartPower Option or the ATEX certified (SIRA 15ATEX2332X) Computational Systems, Inc Model MHM-89004 battery Module.
4. Only an ATEX certified (BVS03ATEXE347, BVS09ATEXE023) Emerson Process Management 375 or 475 Field Communicator is approved for use with this transmitter.
5. The maximum permitted operating temperature of the Rosemount 3308A transmitter is 70 °C. To avoid the effects of process temperature and other thermal effects care shall be taken to ensure that the “Electronics Temperature” does not exceed 70 °C.

B.6.4 International**17** IECEx Intrinsic Safety

Certificate: IECEx FMG 12.0029X

Standards: IEC 60079-0: 2011, IEC 60079-11: 2011

Markings: Ex ia IIC T4 Ga (-55 °C ≤ Ta ≤ +70 °C)

Special Conditions of Certification:

1. The Model 3308 transmitter housing contains aluminum; protect the enclosure to avoid a potential risk of ignition due to impact or friction.
2. The surface resistivity of the polymeric antenna is greater than $1G\Omega$. To avoid electrostatic charge buildup, it must not be rubbed or cleaned with solvents or a dry cloth.
3. For use with only the an IECEx certified (IECEx FMG 12.0029X) Emerson Process Management Model 701PBKFF SmartPower Option or the IECEx certified (IECEx CSA 15.0045X) Computational Systems, Inc Model MHM-89004 battery pack.
4. Only the Emerson Process Management 375 or 475 Field Communicator is approved for use with this transmitter.

- The maximum permitted operating temperature of the Rosemount 3308A transmitter is 70 °C. To avoid the effects of process temperature and other thermal effects care shall be taken to ensure that the “Electronics Temperature” does not exceed 70 °C.

B.6.5 Brazil

I2 INMETRO Intrinsic Safety

Certificate: UL-BR 13.0463X

Standards: ABNT NBR IEC 60079-0:2008 + Errata 1:2011, ABNT NBR IEC 60079-11:2009, ABNT NBR IEC 60079-26:2008

Markings: Ex ia IIC T4 Ga (-55 °C ≤ T_{amb} ≤ +70 °C)

Special Conditions of Certification:

- The Model 3308 transmitter housing contains aluminium; protect the enclosure to avoid a potential risk of ignition due to impact or friction.
- The surface resistivity of the polymeric antenna is greater than 1GΩ. To avoid electrostatic charge buildup, it must not be rubbed or cleaned with solvents or a dry cloth.
- For use with the Emerson Process Management 701PB SmartPower Option only.
- Only the Emerson Process Management 375 or 475 Field Communicator is approved for use with this transmitter.
- The maximum permitted operating temperature of the Rosemount 3308A transmitter is 70 °C. To avoid the effects of process temperature and other thermal effects care shall be taken to ensure that the “Electronics Temperature” does not exceed 70 °C.

B.6.6 China

I3 NEPSI Intrinsic Safety

Certificate: GYJ13.1443X

Standards: GB 3836.1-2010, GB 3836.4-2010, GB 3836.20-2010

Markings: Ex ia IIC T4 Ga (-55 °C ~ +70 °C)

Special Conditions of Certification:

See certificate for details.

B.6.7 Japan

I4 TIIS Intrinsic Safety

Certificate: TC20746

Markings: Ex ia IIC T4 -20 °C ~ +60 °C

Special Conditions of Certification:

See certificate for details.

B.6.8 EAC – Belarus, Kazakhstan, Russia

IM Technical Regulations Customs Union (EAC) Intrinsic Safety

Certificate: RU C-US.Gb05.B.00530

Markings: 0Ex ia IIC T4 Ga X (-55 °C ≤ T_a ≤ +70 °C)

Special Conditions of Certification:

See certificate for details.

B.6.9 Taiwan

注意！

依據 低功率電波輻射性電機管理辦法
第十二條

經型式認證合格之低功率射頻電機，非經許可，公司、商號或使用者均不得擅自變更頻率、加大功率或變更原設計之特性及功能。

第十四條

低功率射頻電機之使用不得影響飛航安全及干擾合法通信；經發現有干擾現象時，應立即停用，並改善至無干擾時方得繼續使用。

前項合法通信，指依電信法規定作業之無線電通信。

低功率射頻電機須忍受合法通信或工業、科學及醫療用電波輻射性電機設備之干擾。

Combinations

KD ATEX and Canadian Intrinsic Safety

KE FM and Canadian Intrinsically Safe

KF ATEX and FM Intrinsic Safety

B.7 Other certifications

U1 Overfill protection

Certificate: Z-65.16-536

TÜV-tested and approved by DIBt for overfill protection according to the German WHG regulations

B.8 Approval drawings

This section contains Factory Mutual installation drawings. The installation guidelines must be followed to maintain certified ratings for installed transmitters.

This section contains the following drawings:

- Rosemount drawing 03308-1010:
Installation Drawing 3308 FM Intrinsic Safety

Figure B-1. Installation Drawing 3308 FM & CSA Intrinsic Safety

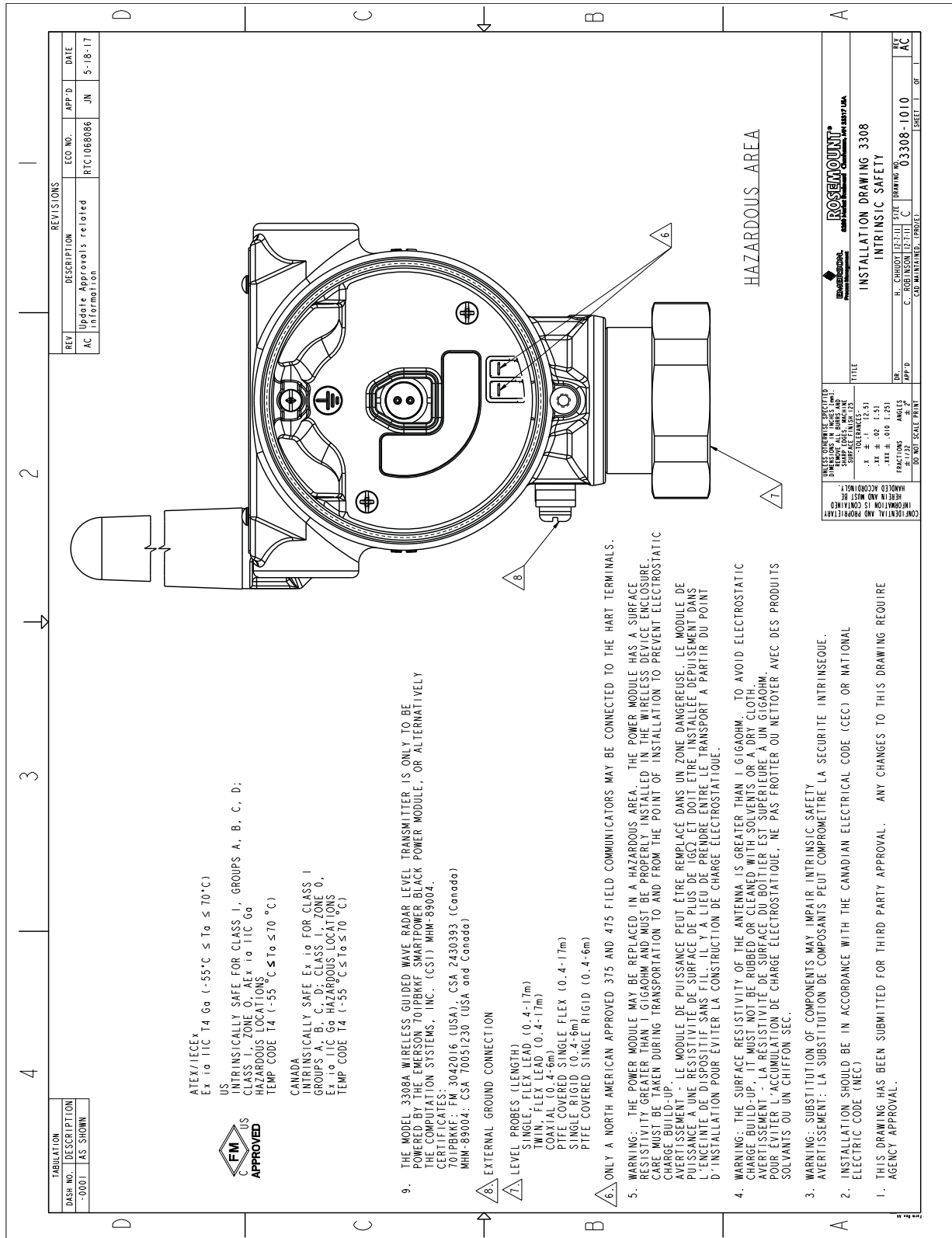

Appendix C High Gain Remote Antenna Option

Safety messages	page 153
Functional and physical specifications	page 154
Review installation considerations	page 154
Transient/lightning considerations	page 155
Install the high gain remote antenna	page 156

C.1 Safety messages

Procedures and instructions in this section may require special precautions to ensure the safety of the personnel performing the operations. Information that raises potential safety issues is indicated by a warning symbol (\triangle). Refer to the following safety messages before performing an operation preceded by this symbol.

\triangle WARNING

- The remote antenna option must be professionally installed using the instructions provided in this section. Failure to follow these installation instructions could invalidate the spectrum regulations and subject the end user to corrective action.
- When installing remote mount antennas for the wireless field device, always use established safety procedures to avoid falling or contact with high-power electrical lines.
- Install remote antenna components for the wireless field device in compliance with local and national electrical codes and use best practices for lightning protection.
- Before installing consult with the local area electrical inspector, electrical officer, and work area supervisor.
- The wireless field device remote antenna option is specifically engineered to provide installation flexibility while optimizing wireless performance and local spectrum approvals.
- To maintain wireless performance and avoid non-compliance with spectrum regulations, do not change the length of cable or the antenna type.
- If the supplied remote mount antenna kit is not installed per these instructions, Emerson™ is not responsible for wireless performance or non-compliance with spectrum regulations.
- Be aware of overhead electrical power lines.

C.2 Functional and physical specifications

C.2.1 General

- Weight: 1.0 lb (0.4 kg)
- Ratings: NEMA® 4X, and IP66/67
- Vibration: 3g Max vibration

C.2.2 Wireless

- Output: *WirelessHART*® 2.4 GHz DSSS (Direct Sequence Spread Spectrum)
- Communication range: 2/3 mile (3,300 feet) (1.0 km) with L.O.S.
- Radio frequency power output from High Gain, Remote (WN option) antenna: Maximum of 40mW (16dBm) EIRP

C.2.3 Coaxial cable

- Coaxial length: 25 feet (7.6 meters) with Type N Connections
- Coaxial material: Heavy duty, low loss LMR400 cable
- Minimum coaxial bend diameter: 1.0 ft. (0.3 meter)

C.2.4 RF Lightning Arrestor

- Type: In-line lightning arrestor
- Electrical connection: Lightning arrestor must be grounded per local electrical codes and regulations.

C.2.5 Mounting bracket

- Horizontal or vertical mast accommodation
- Supported mast diameter: 1.0-2.5 inch (2.5-6.4 cm)
- Aluminum bracket
- Nickel/Zinc plated mounting U-bolts

C.2.6 Antenna

- Remote mount Omni directional Antenna
- Fiberglass & Aluminum construction
- 8 Db Gain
- Meets MIL-STD-810G (Method 510.5, Procedure I and II)

C.3 Review installation considerations

C.3.1 Antenna mounting

Mount antenna vertically ($\pm 5^\circ$)

C.3.2 Antenna height

Mount antenna 14 feet (4.3 meters) above infrastructure with clear line of sight.

C.3.3 Affix coaxial cable

Ensure that coaxial cable is securely affixed to the mast to avoid excessive cable movement.

C.3.4 Install coaxial drip loop

Ensure a drip loop is installed not closer than 1 foot (0.3 meters) from the transmitter. It may also be convenient to affix the drip loop to the lower portion of the mast ensuring that condensation or rainwater will flow away from the coaxial connections.

Figure C-1. Coaxial Drip Loop

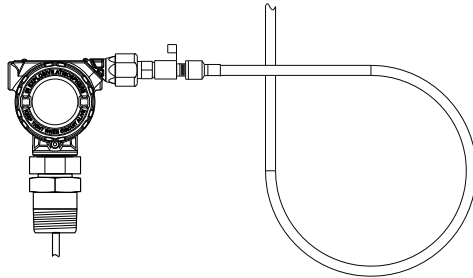

C.3.5 Apply coaxial sealant moisture protection

Utilize the coaxial sealant that is included in the high gain remote mounting kit package. Follow included instructions for application on the coaxial connection.

C.4 Transient/lightning considerations

C.4.1 Gateway transient protection

When installing, consider including transient / lightning protection (not provided) on interface connections (Ethernet, Modbus®, and Coaxial connections) to other equipment.

C.4.2 RF lightning arrestor ground connection

Ensure grounding connection is made on the RF lightning arrestor ground connection point (see Figure C-2).

Figure C-2. Ground Connection Point

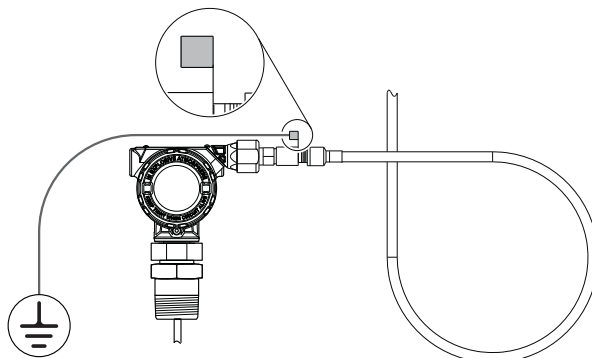

C.5 Install the high gain remote antenna

1. Mount the transmitter following best practice mounting procedures as outlined in [Section 3: Installation](#).
2. Connect the RF lightning arrester to the device and tighten.

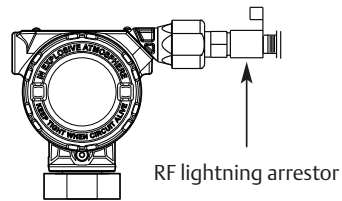

3. Connect the antenna to the mounting bracket and tighten the nut carefully.

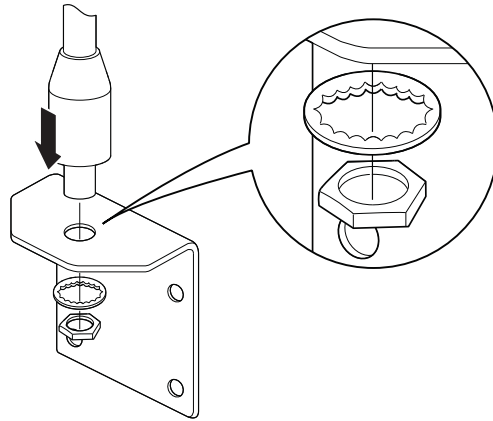

4. Fasten the mounting bracket on the mast. Tighten the nuts loosely first to allow adjustment of the mounting bracket position in [Step 5](#).

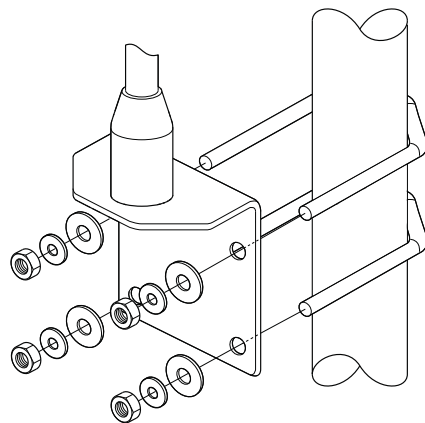

5. Unwind the coaxial cable and connect the cable to both the antenna and the lightning arrester connected to the transmitter, leaving one loop minimum for a drip loop. Ensure the drip loop is lower than the device, allowing water to flow away from the device.

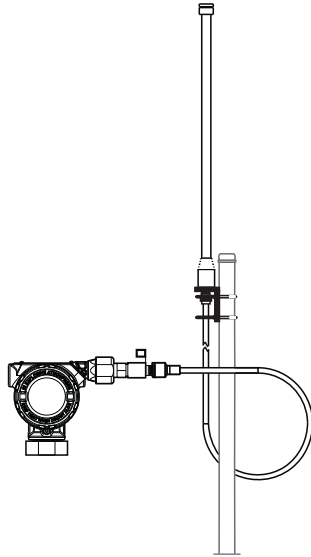

6. Apply the coaxial sealant around each of the coaxial connections and at the RF lightning arrester, making sure the RF connections are completely sealed.

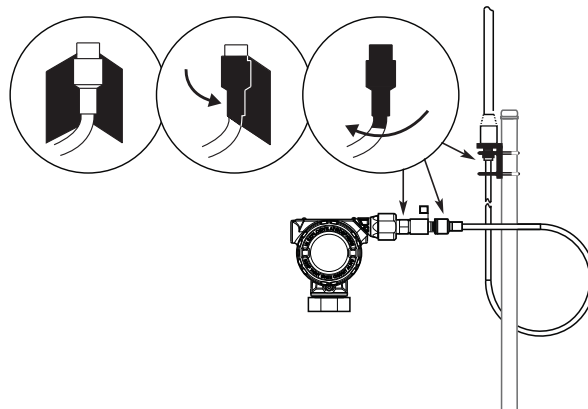

7. Tighten the mounting bracket to the mast. Make sure that antenna is pointed in a vertical direction.

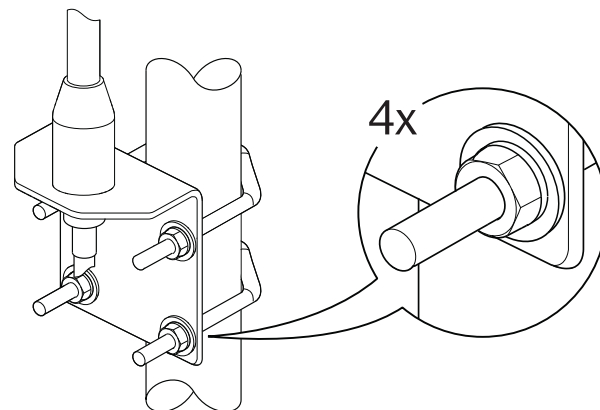

8. Ensure the mounting mast and lightning arrester are grounded according to local/national electrical code (see [Figure C-2](#)).

Appendix D Configuration Parameters

Safety messages	page 159
Menu overview of the Device Descriptor (DD)	page 160
Configuration parameters	page 161

D.1 Safety messages

Procedures and instructions in this section may require special precautions to ensure the safety of the personnel performing the operations. Information that raises potential safety issues is indicated by a warning symbol (⚠). Refer to the following safety messages before performing an operation preceded by this symbol.

⚠ WARNING

Failure to follow safe installation and servicing guidelines could result in death or serious injury.

- Use the equipment only as specified in this manual. Failure to do so may impair the protection provided by the equipment.

Explosions could result in death or serious injury.

- Verify that the operating environment of the gauge is consistent with the appropriate hazardous locations certifications.
- Installation of device in an explosive environment must be in accordance with appropriate local, national and international standards, codes, and practices.
- Ensure device is installed in accordance with intrinsically safe or non-incendive field practices.

Electrical shock can result in death or serious injury.

- Ground device on non-metallic tanks (e.g. fiberglass tanks) to prevent electrostatic charge build-up.
- Care must be taken during transportation of power module to prevent electrostatic charge build-up.
- Device must be installed to ensure a minimum antenna separation distance of 8 in. (20 cm) from all persons.

Process leaks could result in death or serious injury.

- Handle the transmitter carefully.
 - If the process seal is damaged, gas could escape from the tank when removing the transmitter head from the probe.
 - Only qualified personnel should install the equipment.
-

D.2 Menu overview of the Device Descriptor (DD)

The menu tree in Figure D-1 is applicable for both the DD in AMS Wireless Configurator and the Field Communicator.

Figure D-1. Menu Tree

Overview	Device Status		
	Communication Status		
	Primary Purpose Variables		
	Update Rate		
	Join Network		
	Device Information		
Configure	Guided Setup	Initial Setup	Basic Setup
		Wireless Setup	Verify Level
		Optional Setup	Join Device to Network
			Configure Update Rate
			Volume Setup
			Display Setup
	Manual Setup	Device Setup	Echo Tuning
			Check Level Response
			Wireless
			Device Display
			Units
			HART
	Alert Setup	Level Setup	Security
			Device Information
			Power
Service Tools	Alerts	Probe	
	Variables	Geometry	
		Environment	
		Volume	
		Signal Quality Alert	
		High Level Alerts	
	Trends	Low Level Alerts	
		User Defined Alert	
		Lost Measurement	
		Mapped Variables	
		Process	
	Communications	Device	
Signal Quality			
Level			
Distance			
Maintenance	Total Volume		
	Signal Quality		
	Data History		
	Routine Maintenance	Measurement History	
	Reset/Restore	Locate Device	
Echo Tuning	Thresholds	Install New Power Module	
	Near Zone	Verification	
	Echo Curve	Restart Measurement	
	Advanced	Restart Device	
Simulate	Restore Default Settings		

D.3 Configuration parameters

This section presents a brief introduction to all configuration parameters.

The Rosemount™ 3308 Series Transmitter can be configured for level, volume, interface level, interface distance measurements, and interface thickness.

The Rosemount 3308 Series Transmitter can be pre-configured according to the ordering specifications in the Configuration Data Sheet.

D.3.1 Guided setup

Basic setup

The basic transmitter configuration includes setting the tank geometry parameters. For interface measurements the dielectric constant of the top liquid must also be given. For some applications with heavy vapor, the Vapor Dielectric Constant must be given as well.

Figure D-2. Tank Geometry

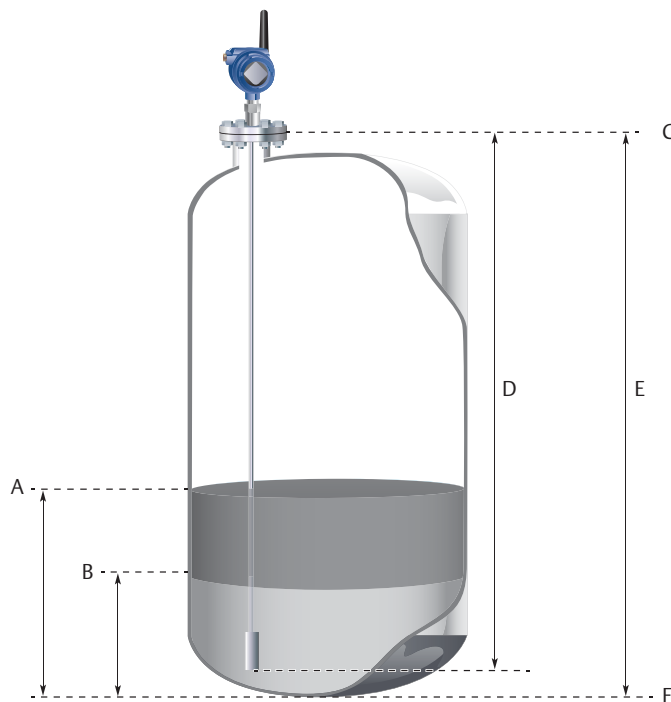

- | | |
|--------------------------|-------------------------|
| A. Product Level | D. Probe Length |
| B. Interface Level | E. Tank Height |
| C. Upper Reference Point | F. Zero Reference Point |

The Upper Reference Point is located at the underside of the threaded adapter, transmitter flange, or Tri Clamp, as illustrated in, as illustrated in [Figure D-3 on page 162](#).

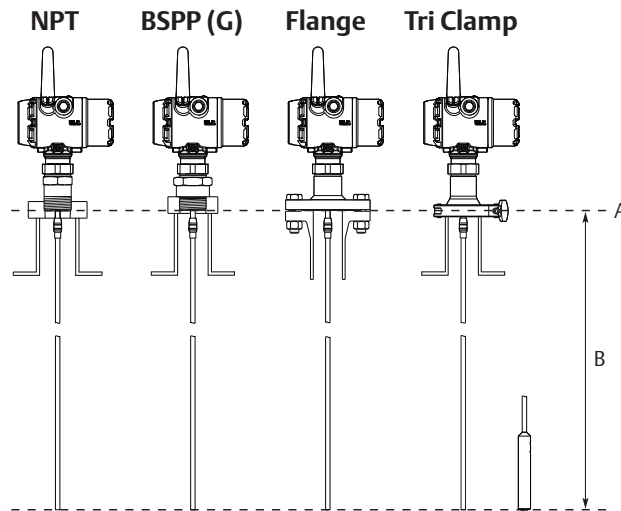
Figure D-3. Upper Reference Point

- A. Upper Reference Point
- B. Probe Length

Probe type

The transmitter is designed to optimize measurement performance for each probe type. The transmitter automatically makes an initial calibration based on the type of probe that is used. (This parameter is pre-configured at factory and only needs to be set if the probe is changed to another type, or if you have installed a spare transmitter)

Select the type of probe that is mounted to the transmitter. Select User Defined probe if your probe can not be found in the list or if you have done modifications to a standard probe.

Probe length

The probe length is the distance between the Upper Reference Point and the end of the probe, see [Figure D-3 on page 162](#). If a weight is used at the end of the probe it shall be included.

This parameter is pre-configured at factory. The probe length must be changed if the probe is shortened, or if you have ordered a spare transmitter head.

Tank height

The Tank Height is the distance from the Upper Reference Point to the bottom of the tank (Zero Reference Point). See [Figure D-2 on page 161](#).

The transmitter measures the distance to the product surface and subtracts this value from the Tank Height to determine the level.

When setting the Tank Height, keep in mind that this value is used for all level measurements performed by the Rosemount 3308 Series Transmitter. The Tank Height must be set in linear (level) units, such as feet or meters, regardless of primary variable assignment.

Mounting type

Select option best describing how device is mounted on the tank.

Inner diameter, pipe/chamber/nozzle

Select the inner diameter for the pipe, chamber or nozzle in which the probe is mounted.

Nozzle height

The distance between the Upper Reference Point (normally the lower side of the device flange) and the end of the nozzle. Note that nozzle may extend into the tank (which should be included in the height).

Measurement mode

Select the Measurement Mode to use in the device. Some modes require software options to be enabled in the device. You can upgrade the device to enable more software options.

Interface Level with Submerged Probe is used for applications where the probe is fully immersed in liquid. In this mode the transmitter ignores the upper product level. See “[Interface measurements with fully submerged probes](#)” on page 105 for more information.

Note

Only use *Interface Level with Submerged Probe* for applications where interface is measured for a fully immersed probe.

Upper product media

Approximate DC value selected from list based on tank content.

Upper product dielectric constant

Enter the Upper Product Dielectric Constant (DC) as accurately as possible. This value is used for setting the automatically calculated amplitude thresholds. In addition the dielectric constant of the upper product is essential for calculating the interface level and the upper product thickness. The default value for the Upper Product Dielectric Constant is 2.

For level measurements, the Upper Product Dielectric Constant parameter corresponds to the dielectric constant of the product in the tank.

If the dielectric constant of the lower product is significantly smaller than the dielectric constant of water, you may need to make special adjustments. The dielectric constant of water is 80. See section “[Example 2: Interface peak not found](#)” on page 97 for further information.

In case the dielectric constant is unknown, then use the Dielectric Constant Guide embedded in the AMS Wireless Configurator as help when configuring the DC.

The AMS Wireless Configurator includes a Dielectric Chart which lists the dielectric constants of a range of products. AMS Wireless Configurator also includes a tool which allows you to calculate dielectric constants based on measurements of the Upper Product Thickness.

1. Select **Configure > Manual Setup > Level Setup > Environment**.
2. Select **Dielectric Constant Guide** and follow the on-screen instructions.

Maximum product level rate

Fastest rate that may occur in the monitored process to (partially) fill or empty this tank. Will be used to calculate the maximum level change between updates. Note that product level rate may be higher during upset conditions.

Note

If the tank is filling or emptying at a high rate, set a faster Update Rate to make sure there is enough safety margin in the system for High/Low Alerts.

Run Check Level Response to make sure that configured Update Rate is sufficient for the application, refer to section “[Optional setup](#)” on page 73.

Tank material

Select material of construction of the tank.

Typical interface condition

The typical interface condition in the tank. Select one of the following conditions:

Table D-1. Typical Interface Conditions

Option	Description
Unknown or Other condition	The typical interface condition is unknown, or varies in such a way that no typical interface condition can be stated.
Layer on top (thin)	The interface thickness is typically thin compared to the bottom layer. The tank mostly contains the bottom product.
Layer at the bottom (thin)	The interface thickness is typically thick compared to the bottom layer. The tank mostly contains the upper product.

D.3.2 Manual setup - Device**Wireless network****Network ID**

Identification number that tells the device which network it belongs to. Obtained from the network administrator.

Join key

A kind of password that the device uses to join the network. Obtained from the network administrator. All sections must contain the same number of characters.

Broadcast information**Message content**

Which content (HART command) to broadcast for a message.

Message variables

Which variables that are included in the content.

Trigger mode

How message will be triggered.

Trigger level

At which level message will be triggered.

First and trigger variable

The 1st variable contained within message which also will be used to trigger a broadcast.

Triggered update rate

This defines how often the broadcast message is sent to the gateway after a user defined trigger level threshold has been crossed. Faster update rates have an impact on the total communications traffic on the network, and power module life.

Default update rate

This defines how often the broadcast message is sent to the gateway. Faster update rates have an impact on the total communications traffic on the network, and power module life.

Device display

Display mode

The display can be configured to different display modes: Disabled, On Demand, or Periodic.

Table D-2. Display Modes

Option	Description
Disabled	The display is always turned off.
On Demand	The display is by default turned off. Selected variable screens will only appear in the end of the diagnostic button screen sequence, refer to “Diagnostic button screen sequence” on page 78 .
Periodic	The display shows selected variable screens in a periodic sequence. A new screen will appear on each wireless update.

Display variables

As default, the level variable will be displayed. If more than one variable is configured, the display will toggle between the values of the chosen variables.

Units

The units for length, volume, and temperature are selectable. After appropriate units have been selected, all configuration parameters and transmitter variables will be expressed in these units.

Length unit

Used unit for Level and Interface Level values.

Volume unit

Used unit for Volume values.

Temperature unit

Used unit for Electronics Temperature value.

HART - Variable mapping

Primary variable

Primary dynamic variable in the HART protocol which will be assigned as a variable from the device.

Secondary variable

Second dynamic variable in the HART protocol which will be assigned as a variable from the device.

Third variable

Third (Tertiary) dynamic variable in the HART protocol which will be assigned as a variable from the device.

Fourth variable

Fourth (Quaternary) dynamic variable in the HART protocol which will be assigned as a variable from the device.

HART - Percent of range

Upper range value

Value for Primary Variable (PV) corresponding to 100% range.

Lower range value

Value for Primary Variable (PV) corresponding to 0% range.

Upper sensor limit

The upper boundary for the range over which the sensor works properly.

Lower sensor limit

The lower boundary for the range over which the sensor works properly.

HART - Data collection

Measurement and status log

Alternatives for data collection in the device.

HART - Variable history

Configure data history

Data History is a series of 12 data points stored in the transmitter. To enable Data History trending select either to enable single data point trending (recommended) or enable filtered trending.

If Data History is enabled, select which Device Variable to store, and then type the time between each sample into the Sample Interval box (4 to 7200 seconds).

Security

Write protection

The device configuration can be write protected.

Over the air upgrade

Wireless upgrade of radio software is possible.

HART lock status

The state of HART write lock in the device.

Device information

Tag

Identifier for the device (max 8 characters) used by host systems. It is recommended to enter both a short and a long tag (they may be the same).

Long tag

Identifier for the device (max 32 characters) used by host systems. It is recommended to enter both a short and a long tag (they may be the same).

Descriptor

User's own description. Not required for operation of the device and can be left out if desired.

Message

User's own information. Not required for operation of the device and can be left out if desired.

Date

User's own information. Manufacturing date by default. Not required for operation of the device and can be left out if desired.

Power

Performance mode

There are two performance modes: Standard and High Performance.⁽¹⁾

Table D-3. Performance Modes

Option	Reference accuracy	Description
Standard	±0.2 in. (±5 mm)	The standard performance mode is suitable for most applications, and gives a long battery life.
High performance	±0.12 in. (±3 mm)	The high performance mode is selectable only for transmitters with profile code U. Each update is based on an increased number of measurements (radar sweeps), which gives improved accuracy and robustness, as well as decreased noise in the output value. This mode also improves performance in difficult applications (e.g. foam, turbulent surface, low dielectric constant) but reduces battery life.

Power mode

Configures the device to take periodic measurements to conserve battery life, or to take continuous measurements.

Note

Always On mode is only recommended for devices connected to line power.

Power source

Optimizes the device to make use of the power source to which it is attached.

1. In earlier versions, the performance modes are called High (Short battery life) and Normal (Long battery life).

D.3.3 Manual setup - Level

Probe**Weight type**

Type of weight at the end of the probe. Only applicable to the flexible single lead probe type.

Table D-4. Weight Types

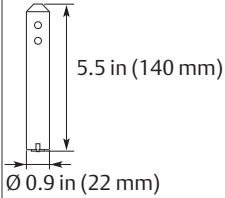
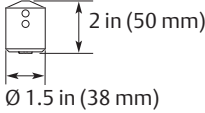
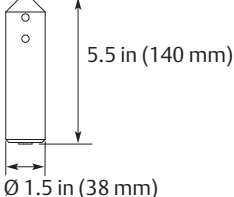
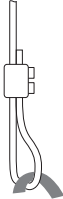
Type	Option code	Description
Unknown		Default
Small	W1	
Short	W2	
Heavy	W3	
Chuck (anchored)	W4	

Upper null zone

Defines how close to the device's Upper Reference Point a level value is accepted. You can extend Upper Null Zone to block out disturbing echoes close to the tank top. View the Echo Curve to find out if there are disturbing echoes close to the tank top.

This parameter should only be changed if there are measurement problems in the upper part of the tank. Such problems may occur if there are disturbing objects close to the probe. By setting the Upper Null Zone, the measuring range is reduced. See [“Changing the upper null zone” on page 103](#) for further information.

Note

Measurements are not performed within the Upper Null Zone, and level alerts located in the Upper Null Zone will not be triggered. Always configure your level alerts below the Upper Null Zone.

For narrow nozzles it may be necessary to increase the Upper Null Zone (UNZ) in order to reduce the measuring range in the upper part of the tank.

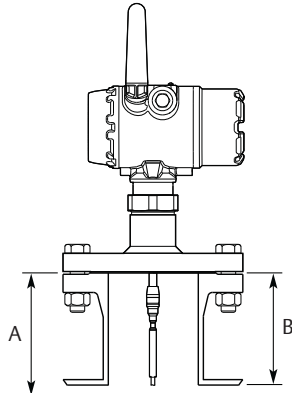
Figure D-4. Upper Null Zone

- A. UNZ
- B. Nozzle height

By setting the UNZ equal to the nozzle height, the impact on the measurement due to interfering echoes from the nozzle will be reduced.

See also section “[Handling disturbances at the top of the tank](#)” on page 102. Amplitude Threshold adjustments may also be needed in this case.

Probe angle (only applicable to rigid probes)

Defines the angle compared to the plumb line at which the device with probe is mounted (0 means that probe is mounted vertically).

Enter the angle between the probe and the vertical line. Do not change this value if the transmitter is mounted with the probe along the vertical line (which is normally the case).

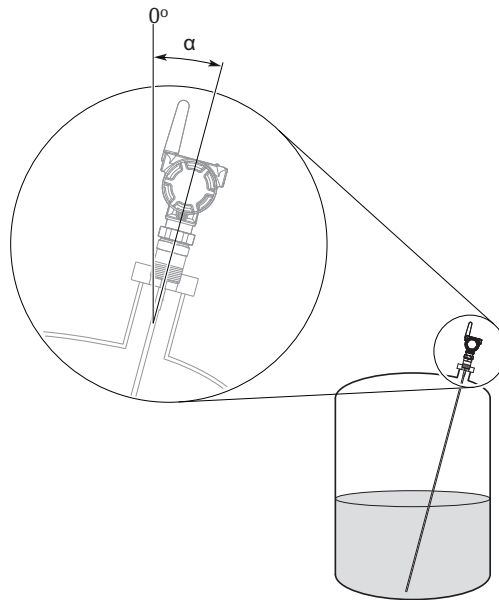
Figure D-5. Probe Angle (α)**Remote housing**

If the transmitter head is mounted apart from the probe, the length of cable between probe and remote housing must be configured.

User defined probe settings

Parameters for user defined probe.

Note

These settings should only be modified for customized probes. The settings are typically provided by factory.

Geometry**Calibration offset**

Difference between surface distance measured by device and the same distance measured by e.g. handgauging with a measurement tape. A positive Calibration Offset value will increase the presented Level value.

Show level below probe end as zero

When this setting is selected and the product surface is at or below the probe end, the level measurement output will be zero.

Note

Only applicable for negative probe end peak.

Environment

Vapor dielectric constant

Enter the dielectric constant (DC) for the vapor gas in the tank. For normal air the vapor DC is close to 1.

In some applications there is heavy vapor above the product surface having a significant influence on the level measurement. In such cases the vapor dielectric can be entered to compensate for this effect.

The default value is equal to 1 which corresponds to the dielectric constant of air. Normally this value does not need to be changed since the effect on measurement performance is very small for most vapors.

Max upper product thickness

Configure the maximum possible thickness for the upper product in this tank. This is the maximum thickness the device will expect for this tank.

Volume

Calculation method

Select method for volume calculation based on tank shape or a strapping table. Strapping table requires entering level-volume pairs in a table.

Diameter (L1)

The diameter of the tank.

Length (L2)

The length (or height if the tank is shaped as a vertical cylinder) of the tank, measured between tank ends.

Strapping table

Use a strapping table if a standard tank type does not provide sufficient accuracy. Use most of the strapping points in regions where the tank shape is non-linear. A maximum of 20 points can be added to the strapping table.

If tank type Strapping Table was chosen, enter how many entries you will use and the actual level and volume points. The strapping points must be entered such that the first point corresponds to the lowest level, and the last point corresponds to the topmost level of the tank.

Figure D-6. Strapping Points

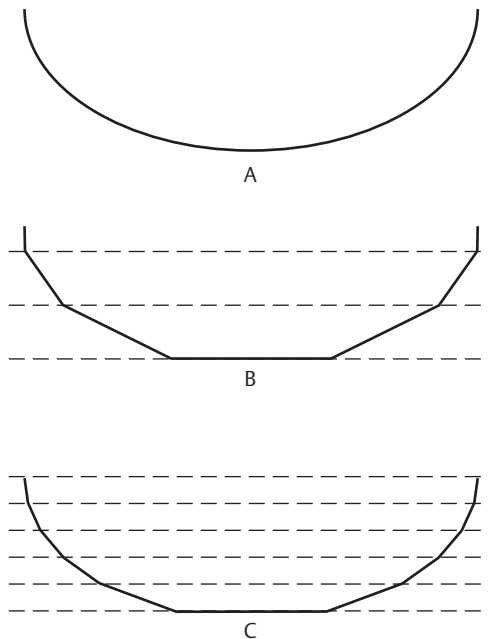

- A. Actual tank bottom may look like this.
- B. Using only three strapping points results in a level-to-volume profile that is more angular than the actual shape.
- C. Using six of the points at the bottom of the tank yields a level-to-volume profile that is similar to the actual tank bottom.

D.3.4

Alert setup

Signal quality alert

Signal Quality is the product surface echo amplitude compared to the surface threshold and noise. The Signal Quality spans from 0 to 10. A low value means that there is a risk for the noise peak to be mistaken for the product surface peak.

Build up on the probe and different surface conditions are factors that can result in a low Signal Quality value. By setting an alert, the Signal Quality value can be used to schedule maintenance to clean the probe.

Note

The Signal Quality depends on probe type and application conditions, as well as the condition of the probe. Even if the probe is clean, Signal Quality may not be a 10.

Suitable alert limits vary from application to application. Appropriate value can be determined by logging Signal Quality over time and viewing maximum/minimum values. The Signal Quality Alert limit should be at least 1, but a better guideline is 2-3.

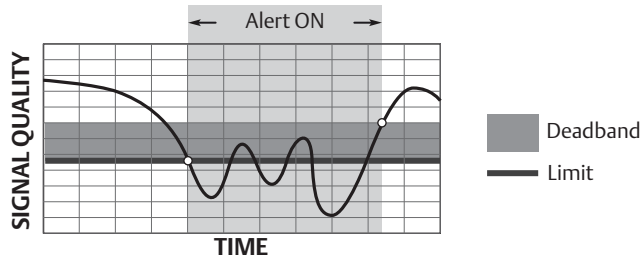
Figure D-7. Signal Quality Alert**Limit**

The Signal Quality value that will trigger the alert.

Deadband

An area of the Signal Quality range where no action occurs to prevent alert from activating/deactivating too quickly.

High/low level alerts

High/Low Level Alerts are triggered when the level goes outside the user defined Limits. There are four standard Level Alerts. Hi Level Alert and Hi-Hi Level Alert are used for rising levels, and Lo Level Alert and Lo-Lo Level Alert are used for falling levels. See [Figure D-8](#) and [Figure D-9](#) for more information.

Limit

The level value that will trigger the alert.

Note

Alert Limit values must be outside the Upper Null Zone, the Blind zones, and areas close to the Blind Zones with reduced accuracy.

Deadband

An area of the Level range where no action occurs to prevent alert from activating/deactivating too quickly.

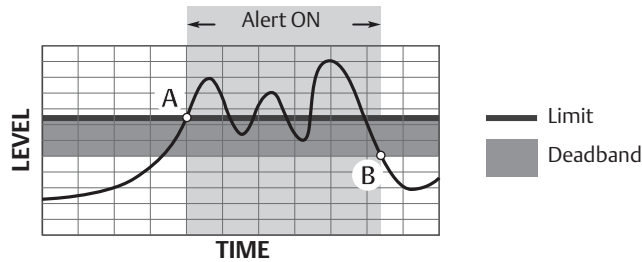
Figure D-8. High Level Alerts for Rising Levels

- A. The alert is active when the level value rises above the alert limit.
- B. The alert turns off when the value falls below the deadband.

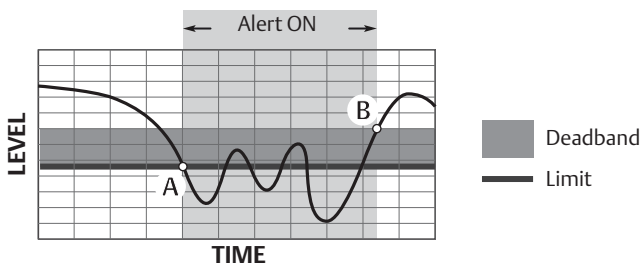
Figure D-9. Low Level Alerts for Falling Levels

- A. The alert is active when the level value falls below the alert limit.
- B. The alert turns off when the value rises above the deadband.

User defined alert

Variable

The variable selected for the alert.

Alert direction

Whether the alert will be triggered above or below the variable's value.

Limit

The variable value that will trigger the alert.

Note

Alert Limit values must be outside the Upper Null Zone, the Blind zones, and areas close to the Blind Zones with reduced accuracy.

Deadband

An area of a variable's range where no action occurs to prevent alert from activating/deactivating too quickly.

Lost measurement

Lost measurement behavior

Configure level value to report if measurement is lost unexpectedly. Choose one of the following actions:

Table D-5. Lost Measurement Behavior Options

Option	Description
Alarm (NaN Value/Bad Status)	If the measurement is lost, the level value will report: <i>"Not a Number / Bad Status"</i> .
Output Full Tank	If the measurement is lost, the level value will correspond to full tank.
Output Empty Tank	If the measurement is lost, the level value will correspond to empty tank.

Number of measurements to hold level

The number of measurements the device will hold the current level if level measurement has been lost. Then it will output level according to Lost Measurement Behavior, if still lost.

For an application where problems with lost measurement due to noise or weak surface echoes are experienced, this parameter value could typically be increased.

The Hold Time value presents for how long the device will hold the current level. The time the current level will be held is calculated out of a combination of both Number of Measurements to Hold Level and the Update Rate.

Note

Make sure you have enough safety margin in your system to manage a delayed condition.

D.3.5 Echo Tuning Thresholds

Figure D-10. Thresholds

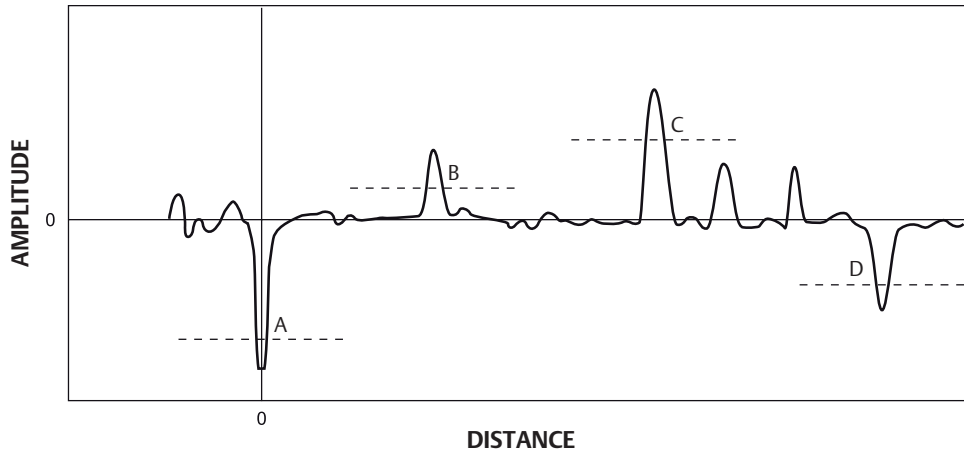

- A. Reference Threshold
- B. Surface Threshold
- C. Interface Threshold
- D. Probe End Threshold

Threshold control

Thresholds can be automatically calculated by device or manually set by user. This setting is valid for all thresholds on the Thresholds tab (Surface, Interface Reference, and Probe End Thresholds).

Surface threshold

Threshold to filter out noise in the echo curve for detection of the Surface. Noise below the threshold is suppressed. The first echo peak closest to the device that crosses and is above the Surface Threshold is the surface echo.

Interface threshold

Threshold to filter out noise in the echo curve for detection of the Interface. The first echo peak after the surface echo that crosses and is above the Interface Threshold is the interface echo.

Reference threshold

Threshold to filter out noise in the echo curve for detection of the Reference peak. The reference peak is a strong negative echo very close to the device.

Probe end threshold

Threshold to filter out noise in the echo curve for detection of the Probe End peak. The probe end peak is a fairly strong positive or negative echo (depending on probe type) that is present at the probe end when tank is empty.

Near zone threshold

Threshold control

The Near Zone Threshold can be automatically calculated by device or manually set by user.

Threshold

Threshold to filter out noise in a zone near the device. Noise below the threshold is suppressed. This threshold replaces the Surface threshold in the zone where it is applicable.

Distance

Distance from Upper Reference Point (normally the lower side of device flange) to point where the near zone threshold ends.

Near zone trimming

Trim near zone

Select to activate trimming.

The Trim Near Zone method is used to fine tune performance in the area close to the tank top. This function is normally not used. Trim Near Zone is typically used if there are problems related to the nozzle. For more information see section “Using the trim near zone function” on page 103.

Near zone has been trimmed

Indicates if the Trim Near Zone method has been used for this device.

Advanced

Peak detection method

Select which peak detection to use for level measurements. For further information on when to use the peak detection method, see section “Resolving thin oil layers” on page 100.

Table D-6. Peak Detection Methods

Option	Description
Peak Center	Surface detected at the first amplitude peak closest to device detected above the Surface Threshold.
Threshold Intersection	Surface detected at first intersection with Surface Threshold.

Figure D-11. Peak Detection Method

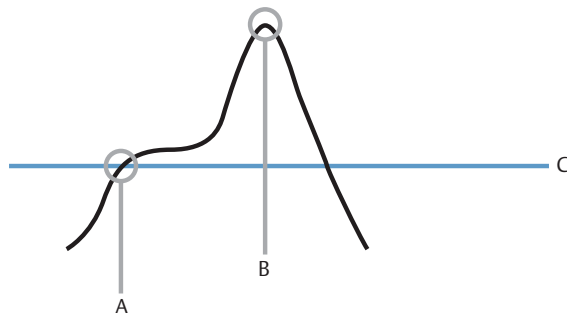

- A. Threshold Intersection
- B. Peak Center
- C. Surface Threshold

Near zone compensation

Improves measurement performance in the zone close to the device by compensating for probe dependent echo signature or recorded echo signature.

If Near Zone Compensation is disabled, neither the probe dependent compensation nor the compensation due to Trim Near Zone will be used by the device.

Echo search window

Select window mode to use for the echo tracking function. Value typically provided by manufacturer.

Window size

Window size used by echo tracking function. Window Size can only be changed when the Eco Search Window mode is set to User Defined. Value typically provided by manufacturer.

Gain factor index

Controls the hardware amplification of the waveform. Value typically provided by manufacturer.

Calibration scale factor

Microwave propagation factor to use. Value typically provided by manufacturer.

Appendix E Alert Message Mapping

E.1 Alert messages and descriptions

This appendix outlines the most important alerts in the HART® command 48 Additional Status Field for the Rosemount 3308 Series. The information in this section can be used by DeltaV™ for alert monitoring, and in the Emerson™ 1420 Wireless Gateway for Additional Status mapping in Modbus®, OPC, etc. A complete list of Additional Status bits is available in the Wireless Gateway.

Table E-1 displays the device variable, variable mapping indexes, and default mapping.

Table E-2 to Table E-4 shows a list of the most important alert messages that may be displayed in the AMS Wireless Configurator and Field Communicator together with the location of the Alert in the HART command 48 Additional Status field. For recommended actions, refer to “Alert messages in AMS Wireless Configurator and Field Communicator” on page 86.

To view Active Alerts, select **Service Tools > Alerts > Active Alerts**.

Table E-1. Device Variables

Index	Device variable	Description	Default mapping (user configurable)
0	Supply Voltage	Measured supply voltage used to determine the health of the power module.	QV (Quaternary)
1	Electronics Temperature	The current temperature at the electronics.	TV (Tertiary)
2	Level	The current level measurement value (from the zero level reference point to the product surface).	PV (Primary)
3	Distance	Distance from the upper reference point to the product surface.	SV (Secondary)
4	Total Volume	The volume of the product at the current level.	Optional
5	Interface Distance	Distance between the upper reference point and the interface between the upper and lower product.	
6	Interface Level	The current interface level value (from the zero level reference point to the interface).	
7	Amplitude Peak 1	Amplitude of the reference peak (see page 4).	
8	Amplitude Peak 2	Amplitude of the product surface peak (see page 4).	
9	Amplitude Peak 3	Amplitude of the interface or probe end peak (see page 4)	
10	Upper Product Thickness	Thickness of the upper product.	
12	Signal Quality ⁽¹⁾	The quality of product surface echo signal compared to surface threshold and noise.	
13	Surface/Noise Margin ⁽¹⁾	Margin between product surface echo signal and noise. Zero indicates a low margin and 10 a high margin.	

1. Requires option code DA1 (HART Diagnostics).

Table E-2. Failure Alerts (F:)

Message	Additional status ⁽¹⁾	Description
Electronics Failure	Byte 8::Bit 6	An electronics error that could impact the device measurement reading has occurred.
Radio Failure	Byte 1::Bit 6	The wireless radio has detected a failure or stopped communicating.
Supply Voltage Failure	Byte 6::Bit 2	The supply voltage is too low and will affect device operation.
Probe Disconnected	Byte 4::Bit 6	The device cannot detect the probe.
Electronics Temperature Critical	Byte 1::Bit 3	The internal temperature of the device has reached critical levels and the integrity of the device electronics may be compromised. Environmental temperature should not exceed device specifications.
Configuration Error	Byte 2::Bit 6	The device has detected a configuration error. Reasons may be multiple. See Table 6-2 on page 87 for a list of detailed Configuration Errors that may be displayed.

1. Location of the Alert in the HART command 48 Additional Status field.

Table E-3. Maintenance Alerts (M:)

Message	Additional status ⁽¹⁾	Description
Supply Voltage Low	Byte 8::Bit 4	The supply voltage is low and may affect Device Operation.
Electronics Temperature Out of Limits	Byte 1::Bit 2	The temperature of the electronics board has exceeded the transmitter's operating range.
Level Measurement Lost	Byte 3::Bit 1	No valid Level reading. Reasons may be multiple: <ul style="list-style-type: none"> ■ No valid surface echo peak in the measuring range. ■ Incorrect transmitter configuration.
Simulation Active	Byte 8::Bit 0	The device is in simulation mode and is not reporting actual information.
Low Signal Quality	Byte 5::Bit 0	The Signal Quality is below the defined alert limit.
Interface Measurement Lost	Byte 3::Bit 0	No valid Interface reading. Reasons may be multiple: <ul style="list-style-type: none"> ■ No valid surface echo peak in the measuring range. ■ Incorrect transmitter configuration.
Capacity Denied	Byte 12::Bit 0	The device has failed to require all of the necessary wireless bandwidth to broadcast at the configured rate(s).

1. Location of the Alert in the HART command 48 Additional Status field.

Table E-4. Advisory Alerts (A:)

Message	Additional status ⁽¹⁾	Description
Database Memory Warning	Byte 0::Bit 2	The device has failed to write to the database memory at some time in the past. Any data written during this time may have been lost.
Non-Critical User Data Warning	Byte 2::Bit 1	A user written parameter does not match expected value.
Volume Range Warning	Byte 4::Bit 7	The level measurement is outside the configured volume range.
Verification Mode Active	Byte 4::Bit 4	The device is in verification mode and is not reporting actual information.
Button Stuck	Byte 1::Bit 5	The button on the Electronics Board is detected as stuck in the active position.
HiHi Level Alert	Byte 5::Bit 4	The level is above the defined limit.
Hi Level Alert	Byte 5::Bit 5	The level is above the defined limit.
Lo Level Alert	Byte 5::Bit 6	The level is below the defined limit.
LoLo Level Alert	Byte 5::Bit 7	The level is below the defined limit.
User Defined Alert	Byte 5::Bit 3	The variable has surpassed the user defined limit.

1. Location of the Alert in the HART command 48 Additional Status field.

Index

A

Active Advertising	64, 92
Active Alerts	65, 79, 81, 84, 86, 179
Agitators	8, 16
Alert Direction	174
Alerts	84
Amplitude Thresholds	
Adjusting	94
AMS Device Manager	62
AMS Wireless Configurator	62, 67, 68, 70, 160
Alerts	86
Anchoring	33
Antenna positioning	55
Applications	9

B

Blind Zone	33
Blind Zones	5

C

Calculation Method	171
Calibration Offset	170
Calibration Scale Factor	178
Centering disc	28
Centering piece	27
Chuck	33, 168
Configuration	
Basic	73
Optional	73

D

Data History	80, 166
Date	167
DC	119, 163, 171
DD	62, 63, 160
Deadband	87, 104, 173, 174
Default Update Rate	165
Descriptor	166
Device Descriptor	62, 63, 160
Device display	56
Alerts	84
Variable screens	77
Device Status	81
DIAG button	78
Diagnostic messages	86
Diameter	171
Dielectric Constant	119, 163
Dielectric Constant Guide	119, 163

Display	56
Kit	56
Pins	56
Rotate	56
Display Mode	165
Display Variables	165
Disturbances	
Top of the tank	102

E

Echo Curve	93, 97, 98, 102, 168, 176
Echo Search Window	178
Emulsion layers	8

F

Field Communicator	71
First and Trigger Variable	164
Flange connection	18
Fourth Variable	165
Free space	17

G

Gain Factor Index	178
Gateway	61, 64, 67, 71, 92
Grounding	54
Guided Setup	72, 73

H

HART Lock Status	166
HART modem	66, 72
Heating coils	16
High High Level Alert	87
High Level Alert	87, 173

I

Inner Diameter	
Pipe/Chamber/Nozzle	162
Installation	
Flange connection	18
Mounting position	16
Power module	55
Procedure	15
Threaded tank connection	36
Interface	8
Criteria	119
Dielectric Constant	119
Fully submerged probes	105
Interface peak	4
Interface Threshold	96, 97, 98, 105, 176

J			
Join Key	67, 68, 92, 99, 164		
L			
Length	171		
Length Unit	165		
Limit	87, 104, 173		
Locate Device	99		
Long Tag	166		
Loose flange	40		
Lost Measurement Behavior	175		
Low Level Alert	87, 173		
Low Low Level Alert	87		
Lower Range Value	87, 166		
Lower Sensor Limit	166		
M			
Mapped Variables	80		
Max Upper Product Thickness	171		
Maximum Measuring Range	6		
Maximum Product Level Rate	163		
Measurement and Status Log	166		
Measurement History	98		
Measurement Mode	87, 91, 163		
Interface Level with Submerged Probe	105		
Product Level	91		
Product Level and Interface Level	4		
Measurement principle	3		
Measuring range	6, 91, 104, 168		
Message	167		
Message Content	164		
Message Variables	164		
Mounting position	16		
Mounting Type	162		
N			
Near Zone Compensation	178		
Near Zone Has Been Trimmed	177		
Near Zone Threshold	102, 103		
Network ID	67, 92, 99, 164		
Non-metallic tanks	14, 19, 54		
Nozzle			
Maximum height	18		
Minimum diameter	18		
Nozzle Height	163		
Number of Updates to Hold Level	175		
O			
OSHA	xi		
Over the Air Upgrade	166		
P			
Peak Center	100, 177		
Peak Detection Method	91, 101, 177		
Percent of Range	166		
Pipe installations			
Centering disc	28		
Plate design	40		
Position the antenna	55		
Possible antenna rotations	56		
Power module			
Environmental considerations	107		
Handling considerations	107		
Installation	55		
Replace	106		
Shipping considerations	107		
Power Source	167		
Primary Variable	165		
Probe			
Anchoring	33		
Changing	109		
Replace	109		
Selection guide	11		
Types	10, 11		
Probe Angle	169		
Probe end peak	4		
Probe End Threshold	176		
Probe Length	3, 5, 23, 33, 109, 162		
Probe Type	162		
Product surface peak	4		
R			
Recommended Measuring Range	6		
Recommended mounting position	16		
Reference peak	4		
Reference Threshold	176		
Replacing power module	106		
Replacing probe	109		
Replacing transmitter head	108		
S			
Secondary Variable	165		
Segmented probe	10, 43		
Service Tools	93		
Shipping Considerations	ix, 110		
Show Level Below Probe End as Zero	170		
Signal Quality	80		
Signal Quality Alert	172		
Deadband	87, 173		
Limit	87, 173		
Simulation Mode	100		
Strapping points	171		
Strapping Table	171		
Surface Threshold	96, 97, 102, 176		
T			
Tag	166		
Tank			
Geometry	161		
Shape	7, 172		

Tank connection	
Flange	18, 38
Loose flange	40
Threaded	36
Tank Height	5, 22, 162
Tank Material	164
TDR	3
Temperature Unit	165
Thin oil layers	100
Third Variable	165
Threaded	36
Threshold Control	176
Threshold Intersection	91, 101, 177
Thresholds	
Adjusting	94
Guidelines	95
Time Domain Reflectometry	3
Transition Zone	173, 174
Transmitter components	10
Transmitter head	
Replace	108
Trends	80
Tri Clamp	41
Trigger Level	164
Trigger Mode	164
Triggered Update Rate	164
Trim Near Zone	103, 177
Troubleshooting	90
Turbulent conditions	16, 90, 106
Typical Interface Condition	91, 164

U

UNZ	103, 104, 169, 173, 174
Update Rate	67, 91, 92, 163, 164, 175
Upper Null Zone	103, 104, 169, 173, 174
Upper Product Dielectric Constant	87, 90, 91, 94
Upper Product Media	163
Upper Range Value	87, 166
Upper Reference Point	4, 22, 102, 103, 161, 162
Upper Sensor Limit	166
User Defined Alert	87, 174
User Defined Probe Settings	170

V

Vapor Dielectric Constant	87, 161
Variables	80
Verify Level	74, 90, 101, 109
Volume Unit	165

W

Weight Type	168
Window Size	178
Wireless Gateway	61, 64, 67, 71, 92
Write Protection	166

Z

Zero Reference Point	3, 5, 22, 161
----------------------	---------------

PRELIMINARY

Global Headquarters

Emerson Automation Solutions

6021 Innovation Blvd.
Shakopee, MN 55379, USA
+1 800 999 9307 or +1 952 906 8888
+1 952 949 7001
RFQ.RMD-RCC@Emerson.com

North America Regional Office

Emerson Automation Solutions

8200 Market Blvd.
Chanhassen, MN 55317, USA
+1 800 999 9307 or +1 952 906 8888
+1 952 949 7001
RMT-NA.RCCRFQ@Emerson.com

Latin America Regional Office

Emerson Automation Solutions

1300 Concord Terrace, Suite 400
Sunrise, FL 33323, USA
+1 954 846 5030
+1 954 846 5121
RFQ.RMD-RCC@Emerson.com

Europe Regional Office

Emerson Automation Solutions Europe GmbH

Neuhofstrasse 19a P.O. Box 1046
CH 6340 Baar
Switzerland
+41 (0) 41 768 6111
+41 (0) 41 768 6300
RFQ.RMD-RCC@Emerson.com

Asia Pacific Regional Office

Emerson Automation Solutions Asia Pacific Pte Ltd

1 Pandan Crescent
Singapore 128461
+65 6777 8211
+65 6777 0947
Enquiries@AP.Emerson.com

Middle East and Africa Regional Office

Emerson Automation Solutions

Emerson FZE P.O. Box 17033
Jebel Ali Free Zone - South 2
Dubai, United Arab Emirates
+971 4 8118100
+971 4 8865465
RFQ.RMTMEA@Emerson.com



[Linkedin.com/company/Emerson-Automation-Solutions](https://www.linkedin.com/company/Emerson-Automation-Solutions)



[Twitter.com/Rosemount_News](https://twitter.com/Rosemount_News)



[Facebook.com/Rosemount](https://www.facebook.com/Rosemount)



[Youtube.com/user/RosemountMeasurement](https://www.youtube.com/user/RosemountMeasurement)



[Google.com/+RosemountMeasurement](https://www.google.com/+RosemountMeasurement)

Standard Terms and Conditions of Sale can be found on the [Terms and Conditions of Sale page](#).

The Emerson logo is a trademark and service mark of Emerson Electric Co. DeltaV, Fisher, Ovation, Plantweb, Rosemount, Rosemount logotype, and SmartPower are trademarks of Emerson.

Bumax is a registered trademark of the Bufab Group.

HART and *WirelessHART* are registered trademarks of the FieldComm Group.

Kalrez and Viton are registered trademarks of DuPont.

MACTek and VIATOR are registered trademarks of MACTek Corporation.

Magnetrol is a registered trademark of Magnetrol International, Incorporated.

Masonellan is a trademark of the General Electric Company.

Modbus is a registered trademark of Gould Inc.

NACE is a registered trademark of NACE International.

NEMA is a registered trademark and service mark of the National Electrical Manufacturers Association.

All other marks are the property of their respective owners.

© 2017 Emerson. All rights reserved.