

Reference Manual
00809-0100-0775, Rev AA
March 2009

Smart Wireless THUM™ Adapter



Smart Wireless THUM™ Adapter

Smart Wireless THUM Adapter Hardware Revision	1
HART® Device Revision	1
Field Communicator Field Device Revision	Dev v2.5 DD v4

NOTICE

Read this manual before working with the product. For personal and system safety, and for optimum product performance, make sure to thoroughly understand the contents before installing, using, or maintaining this product.

The United States has two toll-free assistance numbers and one international number.

Customer Central
1-800-999-9307 (7:00 a.m. to 7:00 P.M. CST)

National Response Center
1-800-654-7768 (24 hours a day)
Equipment service needs

International
1-(952) 906-8888

CAUTION

The products described in this document are NOT designed for nuclear-qualified applications.

Using non-nuclear qualified products in applications that require nuclear-qualified hardware or products may cause inaccurate readings.

For information on Rosemount nuclear-qualified products, contact a Emerson Process Management Sales Representative.

The Smart Wireless THUM Adapter may be protected by one or more U.S. Patents pending. Other foreign patents pending.

NOTICE

Explosions could result in death or serious injury:

Installation of this transmitter in an explosive environment must be in accordance with the appropriate local, national, and international standards, codes, and practices. Please review the approvals section of the THUM reference manual for any restrictions associated with a safe installation.

- Before connecting a Field Communicator in an explosive atmosphere, ensure the instruments are installed in accordance with intrinsically safe or non-incendive field wiring practices.

Process leaks may cause harm or result in death.

- Install and tighten process connectors before applying pressure.

Electrical shock can result in death or serious injury.

- Avoid contact with the leads and terminals. High voltage that may be present on leads can cause electrical shock.

NOTICE

The THUM and all other wireless devices should be installed only after the Smart Wireless Gateway has been installed and is functioning properly. Wireless devices should also be powered up in order of proximity from the Gateway, beginning with the closest. This will result in a simpler and faster network installation.

Section 1 Overview

Safety Messages	page 1-1
Overview	page 1-2
Considerations	page 1-3
Return of Materials	page 1-4

SAFETY MESSAGES

Instructions and procedures in this section may require special precautions to ensure the safety of the personnel performing the operations. Information that potentially raises safety issues is indicated by a warning symbol (). Please refer to the following safety messages before performing an operation preceded by this symbol.

Warnings

WARNING	
Failure to follow these installation guidelines could result in death or serious injury.	<ul style="list-style-type: none">• Make sure only qualified personnel perform the installation.
Explosions could result in death or serious injury.	<ul style="list-style-type: none">• Before connecting a 375 Field Communicator in an explosive atmosphere, make sure the instruments are installed in accordance with intrinsically safe or non-incendive field wiring practices.• Verify that the operating atmosphere of the transmitter is consistent with the appropriate hazardous locations certifications.
Electrical shock could cause death or serious injury.	<ul style="list-style-type: none">• Use extreme caution when making contact with the leads and terminals.

Overview

Manual

This manual is designed to assist in the installation, operation, and maintenance of Smart Wireless THUM Adapter.

Section 1: Overview

- Manual and Transmitter Overview
- Considerations
- Return of Materials

Section 2: Configuration

- Device Sensor Configuration
- Device Network Configuration

Section 3: Mounting

- Mount the Sensor
- Sensor Assembly/Leads
- Grounding

Section 4: Commissioning

- Network Status
- Verify Operation

Section 5: Operation and Maintenance

Appendix A: Specifications and Reference Data

- Specifications
- Dimensional drawings
- Ordering Information

Appendix B: Approvals

- Product Certifications
- Installation Drawings

Transmitter

Features of the Smart Wireless THUM Adapter include:

- An installation-ready solution that provides a variety of mounting options, and transmitter configurations
- Flexibility to meet your most demanding applications
- Wireless output with >99% data reliability delivers rich HART data, protected by industry leading security
- Works with any 2 or 4 wire HART 5.0 or new Device
- Does not affect the approval of the sub-device

Considerations

General

The Smart Wireless THUM Adapter is connected to a HART sub-device. With simple HART configuration, the THUM transmits the HART information from the sub-device unto the WirelessHART network.

Commissioning

The THUM can be commissioned before or after installation. It may be useful to commission it on the bench, before installation, to ensure proper operation and to become familiar with its functionality. When applicable, make sure the instruments are installed in accordance with intrinsically safe or non-incendive field wiring practices. The device will be powered whenever THUM is connected to a powered loop.

Mechanical

Location

When choosing an installation location and position, take into account the need for access to the transmitter. For best performance, the antenna should be vertical with some space between objects in a parallel metal plane such as a pipe or metal framework, as the pipes or framework may adversely affect the performance of the antenna.

Electrical

THUM Power Options

The THUM has two power options; variable current, and fixed current mode.

Variable Current

Variable current mode is the mode that the THUM should be in if the current on the 4-20 mA loop can change between 4 to 20 mA. The THUM will drop 2.25 volts at 2.5 mA and 1 volt at 25 mA. The voltage drop is linear between these two points. The THUM will operate according to standard specifications under this mode.

Fixed Current

Fixed current mode can only be used when the current of the loop will never fall below 20 mA. The THUM will always drop 1 volt across the loop. If the current of the loop falls below 20 mA the THUM, and the rest of the wireless network may not function properly.



This symbol represents protective earth grounding.

Environmental

Verify that the operating atmosphere of the transmitter is consistent with the appropriate hazardous locations certifications.

Temperature Effects

The transmitter will operate within specifications for ambient temperatures between -40 and 185 °F (-40 and 85 °C).

Temperature Limits

Operating Limit	Storage Limit
-40 to 185 °F	-40 to 185 °F
-40 to 85 °C	-40 to 85 °C

RETURN OF MATERIALS

To expedite the return process in North America, call the Emerson Process Management National Response Center toll-free at 800-654-7768. This center, available 24 hours a day, will assist you with any needed information or materials.

The center will ask for the following information:

- Product model
- Serial numbers
- ~~The last process material to which the product was exposed~~

The center will provide

- A Return Material Authorization (RMA) number
- Instructions and procedures that are necessary to return goods that were exposed to hazardous substances

For other locations outside North America, please contact an Emerson Process Management sales representative for further instructions.

NOTE

If the device has been exposed to a hazardous substance, a Material Safety Data Sheet (MSDS) must be included with the returned materials. An MSDS is required by law to be available to people exposed to specific hazardous substances.

Section 2 Configuration

Safety Messages	page 2-1
Device Sensor Configuration	page 2-2
Device Network Configuration	page 2-2

SAFETY MESSAGES

Instructions and procedures in this section may require special precautions to ensure the safety of the personnel performing the operations. Information that potentially raises safety issues is indicated by a warning symbol (). Please refer to the following safety messages before performing an operation preceded by this symbol.

Warnings

WARNING	
Failure to follow these installation guidelines could result in death or serious injury.	<ul style="list-style-type: none">• Make sure only qualified personnel perform the installation.
Explosions could result in death or serious injury.	<ul style="list-style-type: none">• Before connecting a 375 Field Communicator in an explosive atmosphere, make sure the instruments are installed in accordance with intrinsically safe or non-incendive field wiring practices.• Verify that the operating atmosphere of the transmitter is consistent with the appropriate hazardous locations certifications.
Electrical shock could cause death or serious injury.	<ul style="list-style-type: none">• Use extreme caution when making contact with the leads and terminals.
This device complies with Part 15 of the FCC Rules. Operation is subject to the following conditions: This device may not cause harmful interference, this device must accept any interference received, including interference that may cause undesired operation.	
This device must be installed to ensure a minimum antenna separation distance of 20 cm from all persons.	

Connections The THUM is compatible with a number of sub-devices. See section 3 for details on wiring the THUM to different types of sub-devices.

THUM Configuration The THUM will receive any HART communication from a handheld Field Communicator, or AMS®. In order for the THUM to receive HART communication the sub-device must be powered. When using a Field communicator polling must be turned on, the default HART address for the THUM is address 15. When using a Field Communicator, any configuration changes must be sent to the transmitter using the **Send** key (F2). AMS configuration changes are implemented when the **Apply** button is clicked.

AMS® Wireless Configurator

AMS is capable of connecting to devices directly, using a HART modem, or with the Gateway. When configuring on the bench with a HART modem, double click the device icon, then choose the Configure/Setup tab (or right click and select Configure/Setup). Configure the device settings using the Direct Connection menu. When configuring with the Gateway, double click the device icon then choose the Configure/Setup tab (or right click and select Configure/Setup). Configure the device settings using the Wireless Connection menu. To check or change sensor configuration using a 375 Field Communicator, enter the following Fast Key Sequence: 2, 1, 3.

DEVICE NETWORK CONFIGURATION

To communicate with the Gateway, and ultimately the Information System, the transmitter must be configured to communicate with the wireless network. Using a Field Communicator or AMS, enter the Network ID and Join Key so they match the Network ID and Join Key of the Gateway and the other devices in the network. If the Network ID and Join Key are not identical, the transmitter will not communicate with the network. The Network ID and Join Key may be obtained from the Gateway on the **Setup>Network>Settings** page on the web server. Using a 375 Field Communicator, the Network ID can be configured by entering the Fast Key Sequence: 2, 2, 1, 1. The Join Key can also be configured using a 375 Field Communicator with the Fast Key Sequence: 2, 2, 1, 2.

The final device network configuration piece is the Update Rate. There are three update rates for the THUM. Each Update Rate can be configured independently of the other two. One of the Updates is for THUM specific information such as THUM temperature and communication status. The other two Update Rates are for sub-device information. The information that is sent for the sub-device and the frequency that it is sent can all be changed at commissioning or at any other time. At default the Update Rate for all three Updates is 1 minute. The Updates can be changed using AMS or a 375 Field Communicator.

Section 3 Mounting

Safety Messages	page 3-1
Mounting	page 3-2
Direct Mount	page 3-2
Remote Mount	page 3-4
Ground the Transmitter	page 3-5

SAFETY MESSAGES

Instructions and procedures in this section may require special precautions to ensure the safety of the personnel performing the operations. Information that potentially raises safety issues is indicated by a warning symbol (). Please refer to the following safety messages before performing an operation preceded by this symbol.

Warnings

WARNING	
Failure to follow these installation guidelines could result in death or serious injury.	<ul style="list-style-type: none">• Make sure only qualified personnel perform the installation.
Explosions could result in death or serious injury.	<ul style="list-style-type: none">• Before connecting a 375 Field Communicator in an explosive atmosphere, make sure the instruments are installed in accordance with intrinsically safe or non-incendive field wiring practices.• Verify that the operating atmosphere of the transmitter is consistent with the appropriate hazardous locations certifications.
Electrical shock could cause death or serious injury.	<ul style="list-style-type: none">• Use extreme caution when making contact with the leads and terminals.
This device complies with Part 15 of the FCC Rules. Operation is subject to the following conditions: This device may not cause harmful interference, this device must accept any interference received, including interference that may cause undesired operation.	
This device must be installed to ensure a minimum antenna separation distance of 20 cm from all persons.	

Mounting

The THUM can be installed in one of two configurations: Direct Mount, where the THUM is connected directly to the conduit entry of the sub-device, or Remote Mount, where the THUM is mounted separate from the sub-device housing, then connected to the sub-device via conduit. Choose the installation sequence that corresponds to the mounting configuration.

Direct Mount

1. Install the HART® device according to standard installation practices, being sure to use thread sealant on all connections.
2. Using the threaded conduit entry attach the THUM to the HART® device making sure to position the THUM in a vertical position, using a 90-degree elbow, if necessary.
3. Connect the THUM to the HART® sub-device using the wiring diagrams below. See Figures 1, 2, 3, and 4 on the following pages.
4. Close the housing cover on the HART® device, so that metal touches metal, and tighten to safety specifications. Please note that the unit may be damaged by over tightening the cover.

NOTE

The THUM includes two euro splice connectors. The first is a two compartment splice. The second is a three compartment splice which contains a 250 Ohm resistor, to be used if there is not 250 Ohms of resistance in the loop.

Remount Mount

1. Install the HART® device according to standard installation practices, being sure to use thread sealant on all connections.
2. Mount the THUM in a location for good wireless network communication. Make sure to mount the THUM in a vertical position.
3. Using standard practices connect the THUM wires to the sub-device.
4. Wire the THUM to the HART® sub-device using the wiring diagrams below. See Figures 1, 2, 3, and 4 on the following pages.
5. Close the housing cover on the HART® device, so that metal touches metal, and tighten to safety specifications. Please note that the unit may be damaged by over tightening the cover.

NOTE

The THUM includes two euro splice connectors. The first is a two compartment splice. The second is a three compartment splice which contains a 250 Ohm resistor, to be used if there is not 250 Ohms of resistance in the loop.

Wiring

Figure 1. 2 Wire Sub-Device Plus THUM Wiring Diagram

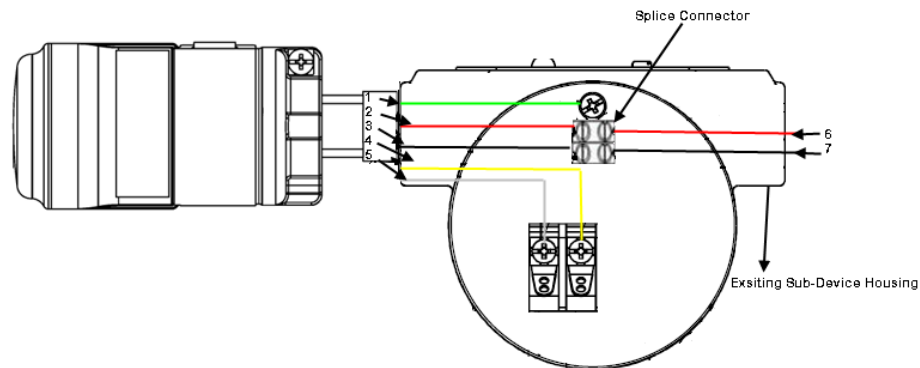

THUM Wires

Wire #	Description
1.	Green connects to case Ground
2.	Red splices to LOOP +
3.	Black splices to LOOP -
4.	Yellow connects to device LOOP +
5.	White connects to device LOOP -

Sub-Device Field Wires

Wire #	Description
6.	4-20 mA LOOP +
7.	4-20 mA LOOP -

NOTE:

In order for the THUM to function properly there must be 250 Ohms resistance in the loop. If the 4-20 mA loop does not have 250 Ohms resistance, wire a 250 Ohm resistor as shown in Figure 2.

Wiring

Figure 2. 2 Wire Sub-Device Plus THUM Wiring Diagram with 250 Ohm Resistor

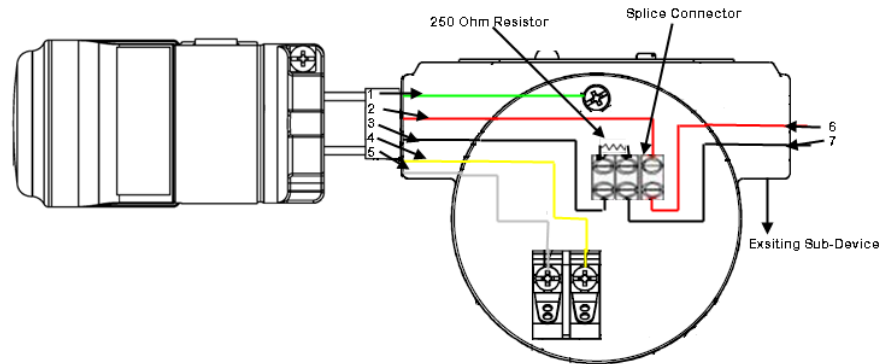

THUM Wires

Wire #	Description
1.	Green connects to case Ground
2.	Red splices to LOOP +
3.	Black splices to LOOP -
4.	Yellow connects to device LOOP +
5.	White connects to device LOOP -

Sub-Device Field Wires

Wire #	Description
6.	4-20 mA LOOP +
7.	4-20 mA LOOP -

NOTE:

In order for the THUM to function properly there must be 250 Ohms resistance in the loop. If the 4-20 mA loop does not have 250 Ohms resistance, wire a 250 Ohm resistor as shown in Figure 2.

Wiring

Figure 3. 4-Wire Sub-Device with Passive 4–20 mA LOOP Plus THUM Wiring Diagram

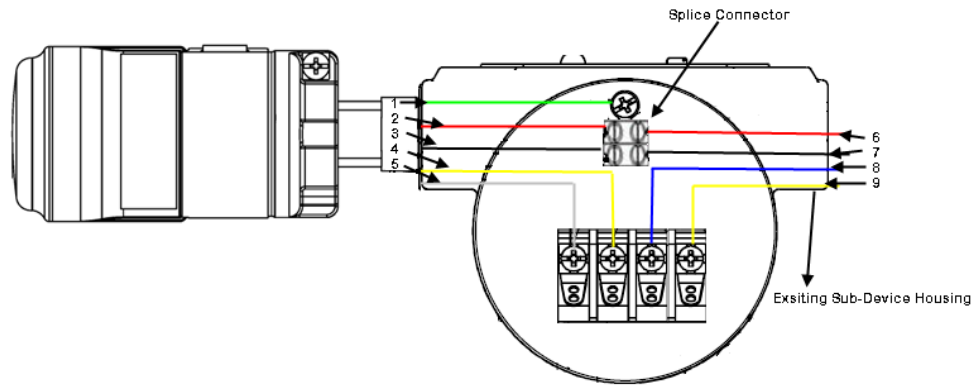

THUM Wires

Wire #	Description
1.	Green connects to case Ground
2.	Red splices to LOOP +
3.	Black splices to LOOP -
4.	Yellow connects to device LOOP +
5.	White connects to device LOOP -

Sub-Device Field Wires

Wire #	Description
6.	4–20 mA LOOP +
7.	4–20 mA LOOP -
8.	Power Wire -
9.	Power Wire +

NOTE:

In order for the THUM to function properly there must be 250 Ohms resistance in the loop. If the 4–20 mA loop does not have 250 Ohms resistance, wire a 250 Ohm resistor as shown in Figure 4.

Wiring

Figure 4. 4-Wire Sub-Device with Passive 4–20 mA LOOP Plus THUM Wiring Diagram with 250 Ohm resistor

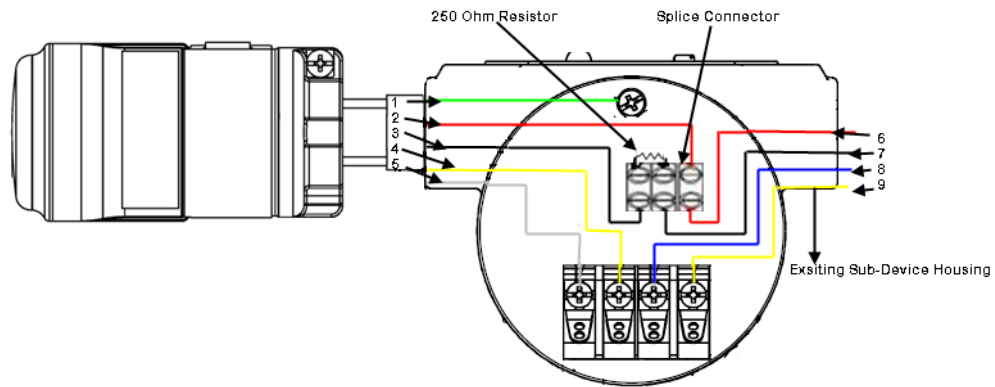

THUM Wires

Wire #	Description
1.	Green connects to case Ground
2.	Red splices to LOOP +
3.	Black splices to LOOP -
4.	Yellow connects to device LOOP +
5.	White connects to device LOOP -

Sub-Device Field Wires

Wire #	Description
6.	4–20 mA LOOP +
7.	4–20 mA LOOP -
8.	Power Wire -
9.	Power Wire +

NOTE:

In order for the THUM to function properly there must be 250 Ohms resistance in the loop. If the 4–20 mA loop does not have 250 Ohms resistance, wire a 250 Ohm resistor as shown in Figure 4.

Wiring

Figure 5. 4-Wire Sub-Device with Active 4–20 mA LOOP Plus THUM Wiring Diagram

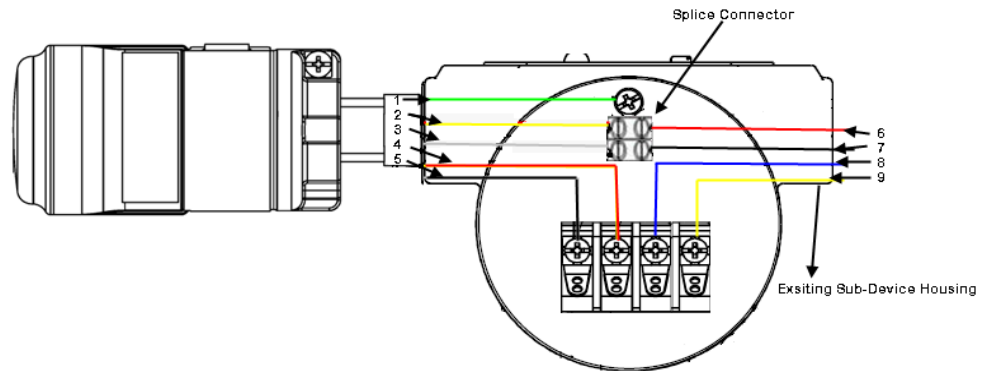

THUM Wires

Wire #	Description
1.	Green connects to case Ground
2.	Yellow splices to LOOP +
3.	White splices to LOOP -
4.	Red connects to device LOOP +
5.	Black connects to device LOOP -

4-20 mA LOOP Field Wiring

Wire #	Description
6.	4–20 mA LOOP +
7.	4–20 mA LOOP -
8.	Power Wire -
9.	Power Wire +

NOTE:

In order for the THUM to function properly there must be 250 Ohms resistance in the loop. If the 4–20 mA loop does not have 250 Ohms resistance, wire a 250 Ohm resistor as shown in Figure 6.

Wiring

Figure 6. 4-Wire Sub-Device with Active 4–20 mA LOOP Plus THUM Wiring Diagram with 250 Ohm resistance

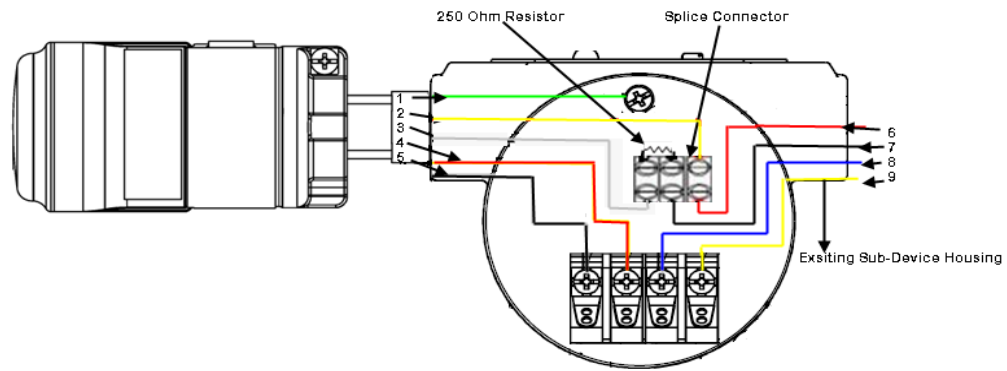

THUM Wires

Wire #	Description
1.	Green connects to case Ground
2.	Yellow splices to LOOP +
3.	White splices to LOOP -
4.	Red connects to device LOOP +
5.	Black connects to device LOOP -

4-20 mA LOOP Field Wiring

Wire #	Description
6.	4–20 mA LOOP +
7.	4–20 mA LOOP -
8.	Power Wire -
9.	Power Wire +

NOTE:

In order for the THUM to function properly there must be 250 Ohms resistance in the loop. If the 4–20 mA loop does not have 250 Ohms resistance, wire a 250 Ohm resistor as shown in Figure 6.

Wiring

Figure 7. 4-Wire Sub-Device with no 4–20 mA LOOP Plus THUM Wiring Diagram

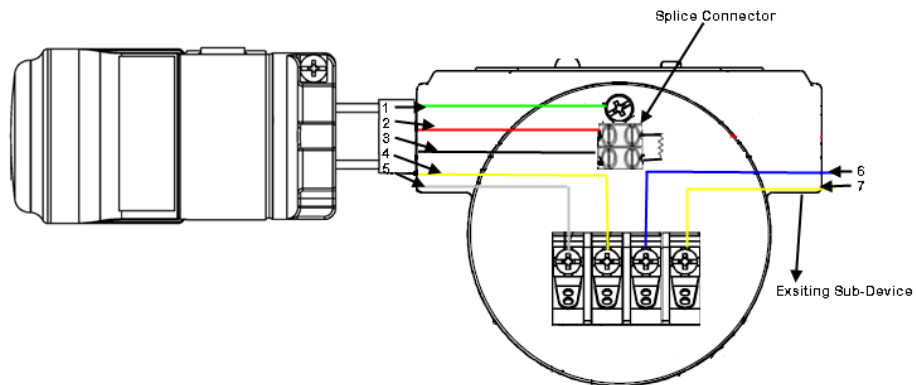

THUM Wires

Wire #	Description
1.	Green connects to case Ground
2.	Red connects to LOOP +
3.	Black connects to LOOP -
4.	Yellow connects to 250 Ohm Resistor
5.	White connects to 250 Ohm Resistor

Sub-Device Field Wires

Wire #	Description
6.	Power Wire -
7.	Power Wire +-

NOTE:

In order for the THUM to function properly there must be 250 Ohms resistance in the loop. If the 4–20 mA loop does not have 250 Ohms resistance, wire a 250 Ohm resistor as shown in Figure 7.

Section 4 Commissioning

Safety Messages	page 3-1
Verify Operations	page 3-2

SAFETY MESSAGES

Instructions and procedures in this section may require special precautions to ensure the safety of the personnel performing the operations. Information that potentially raises safety issues is indicated by a warning symbol (). Please refer to the following safety messages before performing an operation preceded by this symbol.

Warnings

WARNING	
Failure to follow these installation guidelines could result in death or serious injury.	<ul style="list-style-type: none">• Make sure only qualified personnel perform the installation.
Explosions could result in death or serious injury.	<ul style="list-style-type: none">• Before connecting a 375 Field Communicator in an explosive atmosphere, make sure the instruments are installed in accordance with intrinsically safe or non-incendive field wiring practices.• Verify that the operating atmosphere of the transmitter is consistent with the appropriate hazardous locations certifications.
Electrical shock could cause death or serious injury.	<ul style="list-style-type: none">• Use extreme caution when making contact with the leads and terminals.
This device complies with Part 15 of the FCC Rules. Operation is subject to the following conditions: This device may not cause harmful interference, this device must accept any interference received, including interference that may cause undesired operation.	
This device must be installed to ensure a minimum antenna separation distance of 20 cm from all persons.	

Verify Operations Operation can be verified in two locations, using the 375 Field Communicator, or at the Gateway via the Wireless Gateway's integrated web server.

375 Field Communicator

To verify device operation using a HART Field Communicator, a 648 DD is required.

Function	Key Sequence	Menu Items
Network	1, 3, 3	Smart Power, Network ID, Set Join Key, Radio State

Smart Wireless Gateway

To verify device operation using the 1420 Wireless Gateway's integrated web server, navigate to the Explorer>Status page. This page will show whether the device has joined the network and if it is communicating properly.

If the THUM was configured with the Network ID and Join Key and sufficient time for network polling has passed, the transmitter will be connected to the network. To verify connectivity, open the 1420 Wireless Gateway's integral web interface and navigate to the Explorer>Status page.



This page will display the transmitter’s tag, PV, SV, TV, QV, Last Update, Update Rate, Battery Voltage, and Status. A green status indicator means that the device is working properly. A red indicator means that there is a problem with either the device or its communication path. For more detail on a specific device, click on the tag name.

Troubleshooting

The most common cause of incorrect operation is the Network ID and Join Key. The Network ID and Join Key in the device must match that of the Gateway. The Network ID and Join Key may be obtained from the Gateway on the Setup>Network>Settings page on the web server.



Section 5 Operations and Maintenance

Safety Messages	page 5-1
LCD Screen Messages	page 5-2

SAFETY MESSAGES

Instructions and procedures in this section may require special precautions to ensure the safety of the personnel performing the operations. Information that potentially raises safety issues is indicated by a warning symbol (). Please refer to the following safety messages before performing an operation preceded by this symbol.

Warnings

WARNING
<p>Failure to follow these installation guidelines could result in death or serious injury.</p> <ul style="list-style-type: none">• Make sure only qualified personnel perform the installation.
<p>Explosions could result in death or serious injury.</p> <ul style="list-style-type: none">• Before connecting a 375 Field Communicator in an explosive atmosphere, make sure the instruments are installed in accordance with intrinsically safe or non-incendive field wiring practices.• Verify that the operating atmosphere of the transmitter is consistent with the appropriate hazardous locations certifications.
<p>Electrical shock could cause death or serious injury.</p> <ul style="list-style-type: none">• Use extreme caution when making contact with the leads and terminals.
<p>This device complies with Part 15 of the FCC Rules. Operation is subject to the following conditions: This device may not cause harmful interference, this device must accept any interference received, including interference that may cause undesired operation.</p>
<p>This device must be installed to ensure a minimum antenna separation distance of 20 cm from all persons.</p>

Startup Sequence

Due to the power scavenging of the THUM different capabilities will be available at different times after startup. Immediately after startup configuration of the THUM is available. This includes all network settings including Network ID and Join Key, and Update Rate. The THUM will not start to join the network until the radio turns completely on. This will not happen until up to 3 minutes after startup depending on the current of the loop.

Diagnostic

To determine if the THUM has joined the network, go to the Explorer page on the Gateway and look for the THUM tag number as shown below.

The screenshot shows the 'Smart Wireless Gateway' interface. On the left is a tree view with 'thum1420' expanded to 'Explorer'. The main area displays a table with the following data:

HART Tag	HART status	Last update	PV	SV	TV	QV	Burst rate
THUM 00-E1	●	03/12/09 16:00:23	NaN DegC ●				00:01:00
THUM 01-10	●	03/12/09 16:01:13	NaN DegC ●				16

Appendix A Specifications and Reference Data

Specifications	page A-1
Dimensional Drawings	page A-3
Ordering Information	page A-4

Specifications Functional Specifications

Input
Any 2- or 4-wire HART 5.0 powered device.

Output
WirelessHART.

Humidity Limits
0–100% relative humidity

Burst Rate
User selectable, 8 sec. to 60 min.

Physical Specifications

Electrical Connections
The THUM™ is connected into a powered 4–20 mA loop, powering itself by scavenging power. The THUM causes a voltage drop across the loop. The drop is linear from 2.25 volts at 3.5 mA to 1.2 volts at 25 mA, but does not effect the 4–20mA signal on the loop. Under fault conditions, the maximum voltage drop is 2.5 volts.

Power Supply
Minimum load on loop 250 Ohms to maintain normal operating functions of the sub-device, the power in the loop must have at least a 2.5 V margin at a 250 Ohm load.

HART Communicator Connections
Utilize sub-device HART connections.

Materials of Construction
Enclosure
Housing - Low-copper aluminum
Paint - Polyurethane

Antenna
Poly butadine terephthalate (PBT)/Polycarbonate (PC) integrated omnidirectional antenna

Weight
.65 lbs. (.29 kg)

Enclosure Ratings
Housing option code D is NEMA 4X, and IP66.

Performance
Specifications

ElectroMagnetic Compatibility (EMC)

All Models:
Meets all relevant requirements of EN61326-1 (2006)

Vibration Effect

Output unaffected when tested per the requirements of IEC60770-1 field or pipeline with high vibration level (10-60 Hz 0.21mm displacement peak amplitude / 60-2000 Hz 3g). Output unaffected when tested per the requirements of IEC60770-1 field with general application or pipeline with low vibration level (10-60 Hz 0.15mm displacement peak amplitude / 60-500 Hz 2g).

Temperature Limits

Operating Limit	Storage Limit
-40 to 185 °F	-40 to 185 °F
-40 to 85 °C	-40 to 85 °C

Output Specifications

The THUM™ allows WirelessHART™ communication between the HART device it is connected to and the Smart Wireless Gateway.

DIMENSIONAL DRAWINGS

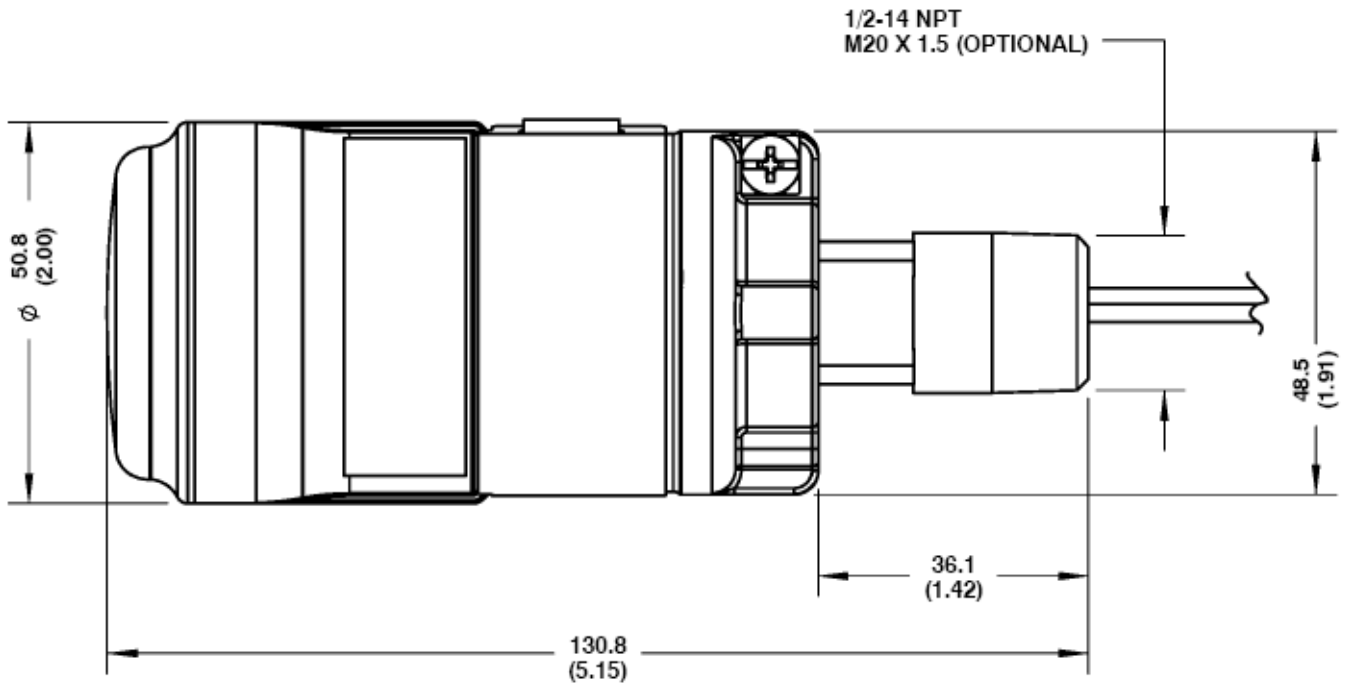

Ordering Information

Model	Product Description
775	Smart Wireless THUM™ Adapter
Code	Output
X	Wireless
Code	Housing
D	Aluminum
Code	Mounting Connection
1	1/2 - 14 NPT
Code	PlantWeb Functionality
1	HART® Data
Code	Certification
I5	FM Intrinsically Safe, Non-incendive
I6	CSA Intrinsically Safe
I1	ATEX Intrinsically Safe
I7	IECEX Intrinsically Safe
NA	No Approval
Code	Wireless Options
Wireless Transmitter Rate	
WA	User Configurable Transmit Rate
Operating Frequency and Protocol	
3	2.4 GHz DSSS, WirelessHART
Antenna	
WK	Omnidirectional, Integral Antenna
9	Power Scavenging
Typical Model Number: 775XD11E5WA3WK9	

Appendix B Product Certifications

Approved Manufacturing Locations	page B-1
Telecommunication Compliance	page B-1
European Union Directive Information	page B-1
Ordinary Location Certification for FM	page B-2
Hazardous Locations Certificates	page B-2

Approved Manufacturing Locations

Rosemount Inc. – Chanhassen, Minnesota, USA

Telecommunication Compliance

All wireless devices require certification to ensure that they adhere to regulations regarding the use of the RF spectrum. Nearly every country requires this type of product certification. Emerson is working with governmental agencies around the world to supply fully compliant products and remove the risk of violating country directives or laws governing wireless device usage.

FCC and IC

This device complies with Part 15 of the FCC Rules. Operation is subject to the following conditions: This device may not cause harmful interference. This device must accept any interference received, including interference that may cause undesired operation.

This device must be installed to ensure a minimum antenna separation distance of 20 cm from all persons.

European Union Directive Information

The EC declaration of conformity for all applicable European directives for this product can be found at www.rosemount.com. A hard copy may be obtained by contacting an Emerson Process Management representative.

ATEX Directive (94/9/EC)
Emerson Process Management complies with the ATEX Directive.

Electro Magnetic Compatibility (EMC) (2004/108/EC)
Emerson Process Management complies with the EMC Directive

Radio and Telecommunications Terminal Equipment Directive (R&TTE) (1999/5/EC)
Emerson Process Management complies with the R&TTE Directive.

Ordinary Location Certification for FM

As standard, the transmitter has been examined and tested to determine that the design meets basic electrical, mechanical, and fire protection requirements by FM, a nationally recognized testing laboratory (NRTL) as accredited by the Federal Occupational Safety and Health Administration (OSHA).

Hazardous
Locations
Certificates

North American Certifications

Factory Mutual (FM) Approvals

I5 FM Intrinsic Safety and Non-incendive
Intrinsically Safe for Class I/II/III, Division 1, Groups A, B, C, D,E, F, and G.
Zone Marking: Class I, Zone 0, AEx ia IIC
Temperature Codes T4 (Tamb = -50 to 70° C)
Non-incendive for Class I, Division 2, Groups A, B, C, and D.
Intrinsically safe and non-incendive when installed according
to Rosemount Drawing 00775-XXXX.
Enclosure Type 4X/IP66

Warning: The antenna does not meet the surface resistivity requirements and, to avoid electrostatic charging, it must only be cleaned with a damp cloth.

CSA - Canadian Standards Association

I6 CSA Intrinsic Safety
Intrinsically Safe for Class I, Division 1, Groups A, B, C, and D.
Intrinsically safe and non-incendive when installed according
to Rosemount Drawing 00775-XXXX

Warning: The antenna does not meet the surface resistivity requirements and, to avoid electrostatic charging, it must only be cleaned with a damp cloth.

European Certifications

II ATEX Intrinsic Safety
Certificate No.: See Certificate II 1G
Ex ia IIC T5 (Ta = -50 °C to 40 °C)
Ex ia IIC T4 (Ta = -50 °C to 70 °C)
IP66

CE 1180

TABLE 1. Input Parameters

Loop Power

Ui = 30V

Li = 200 mA

Pi = 1.0 W

Ci = 0

Li = 0

Special Conditions of Safe Use (X)

The antenna does not meet the surface resistivity requirements and, to avoid electrostatic charging, it must only be cleaned with a damp cloth.

Hazardous
Locations
Certificates

IECEX Certifications

I7 IECEX Intrinsic Safety
Certificate No.: See Certificate
Ex ia IIC T5 (Tamb = -50 °C to 40 °C)
Ex ia IIC T4 (Tamb = -50 °C to 70 °C)
IP66

TABLE 2. Sensor Parameters

Loop Power
Ui = 30V
Li = 200 mA
Pi = 1.0 W
Ci = 0
Li = 0

Special Conditions of Safe Use (X)

The antenna does not meet the surface resistivity requirements and, to avoid electrostatic charging, it must only be cleaned with a damp cloth.

*The Emerson logo is a trade mark and service mark of Emerson Electric Co.
Rosemount and the Rosemount logotype are registered trademarks of Rosemount Inc.
PlantWeb is a registered trademark of one of the Emerson Process Management group of companies.
HART is a registered trademark of the HART Communication Foundation.
Lexan and Noryl are registered trademark of General Electric.
All other marks are the property of their respective owners.*

Standard Terms and Conditions of Sale can be found at www.rosemount.com/terms_of_sale

Emerson Process Management

Rosemount Inc.
8200 Market Boulevard
Chanhassen, MN 55317 USA
T (U.S.) 1-800-999-9307
T (International) (952) 906-8888
F (952) 949-7001

www.rosemount.com



Emerson Process Management
Heath Place
Bognor Regis
West Sussex PO22 9SH
England
T 44 (1243) 863 121
F 44 (1243) 867 554

**Emerson Process Management Asia
Pacific Private Limited**
1 Pandan Crescent
Singapore 128461
T (65) 6777 8211
F (65) 6777 0947
AP.RMT-Specialist@emersonprocess.com