

Changes or modifications not expressly approved by the party responsible for compliance could void the user's authority to operate the equipment

SA-01
Supervised Wireless PIR



CE 0678

INSTALLATION INSTRUCTIONS
AND IMPORTANT INFORMATION

ROSSLARE

P/N:
9J-REL-001/0706-0670001-00

INTRODUCTION (FAQ's)

Q: What is a PIR - Passive Infra Red detector ?
A: A PIR senses slight motion within a coverage pattern by detecting Infra-red energy with a PYRO sensor. Serving as an anti-intrusion sensor, the PIR can monitor open space within line of sight.

Q: What is Wireless and how can it benefit me ?
A: Wireless is the use of Radio signal to transmit a signal from any sensor to the panel, eliminating setting wire ducts, extra cabling materials or drilling, saving time and money.

Q: What is Supervisor or Supervised sensor ?
A: Supervisor means a sensor continuously reports to the receiver or panel to confirm status of the sensor and its presence. If the receiver fails to hear from a sensor within a pre-programmed time then it will presume a sensor is missing and notify. This means added security.

INTRODUCTION (FAQ's) - continued:

Q: What is LOW BATT detection ?
A: For all supervised sensors, LOW BATT detection is when a sensor continuously measures its battery state and will transmit a low battery signal to the panel when voltage drops below a certain level. This alerts the user in advance to replace the battery.

Q: What is CASE TAMPER ?
A: Case Tamper means the detection of tampering with sensor by opening the case. Case tamper will alert the panel when any sensor is opened.

Q: What is BACK TAMPER ?
A: Once the sensor is mounted and activated, Back Tamper ensures that the sensor is not removed or vandalized by detecting removal from the wall or corner. Back tamper will alert the panel in such cases. Means added security.

FEATURES OF SA-01 - Performance PIR

The SA-01 Supervised Wireless PIR is a high-performance intrusion sensor made with the highest level of technology to make it ideal for residential and commercial applications. The following features are standard.

Standard Lens - Included
Supervisor
Case & Back Tamper
ASIC and Microprocessor Technology
Up to 5-yr. Battery Life with APS
APS (Auto Power Saver)
Ultra-low Current Consumption
Movement and Speed Spectrum Analysis
Readily Replaceable 3V-CR123 Lithium Battery - Incl.
SMD Component technology
Walk Test Function
RF Transmission test Function
Ultra-Bright L.E.D.
Optional Corner Mount Bracket
Optional Curtain & Long Range Lens

INSTALLATION - Performance Criteria

The SA-01 PIR detects motion across a beams pattern by detecting the infrared energy of moving body. The larger the moving body, and the faster it moves, the detection is easier.

- AVOID: Placing the PIR facing windows, or in direct sunlight as this heat energy can cause false alarms.
- AVOID: Mounting on or near large metal surfaces and too many concrete or steel walls away from the panel. This may interfere or block the wireless signals. Make sure to test the range from any location by using the RF Test Procedure to ensure reception.
- AVOID: Placing near or over heat and air ducts, ovens, heat sources, radiators, air cons as this may cause a false detection.
- IMPORTANT NOTE: PIR works according to field of view and cannot detect through walls. Avoid placing near obstructions such as large plants, curtains and continuously moving objects.

STEP-1 INSTALLING THE BATTERY

Use only the specified 3V Lithium Battery. See FIG 1. Preferably one of the following brands and model #.

Energizer CR123A / Duracell DL 123A / Panasonic CR 123A / Varta 123A, and other name brands.

- 1) Unscrew the case locking screw and remove the front cover. CAUTION: Do not touch or clean the PYRO element as this may damage the sensor.
- 2) For a new unit, simply remove the plastic strip contact breaker. For replacement remove the battery by applying pressure from below. CAUTION: Notice the polarity. Replace with a fresh one.
- 3) Dispose of the old battery properly. Do not incinerate, heat, disassemble, recharge.
- 4) Press the TEST BUTTON on the front of the housing until the LED begins to flash in the RF TEST MODE (3+ seconds) LED Flashing indicates function OK.
- 5) Close the front cover and replace locking screw

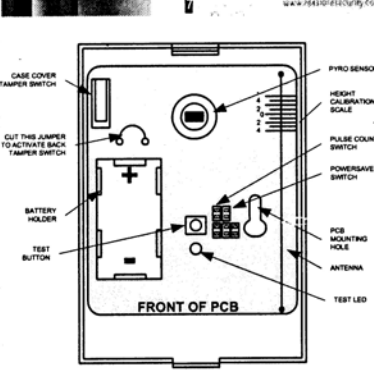

Fig 1: Front of PCB

STEP-2 SELECTING THE LOCATION

- 1) Select a location within a room or hallway that best matches the criteria on block 4.
- 2) Make sure that the PIR will be mounted on a non-moving, non-vibrating surface, or corner of the room.
- 3) Perform the RF Test from the proposed mounting location to ensure that the sensor can be received by the panel.
- 4) Select the appropriate lens and mount the PIR in the location.

STEP-3 SELECT APPROPRIATE LENS

The SA-01 comes equipped with a standard wide angle lens which is good for almost all applications. When there is a special need to exchange lens, the following Lenses are available;

L01 - Standard - EXTRA WIDE ANGLE LENS
L02 - Optional - LONG RANGE LENS (HALLWAY)
L03 - Optional - VERTICAL CURTAIN LENS

For Lens patterns and tables, please see FIG 5.6.

STEP-4 CHANGING THE LENS (FIG 2)

- 1) This step is not necessary unless installing a custom lens to the PIR or replacing a damaged lens.
- 2) Remove the case locking screw and remove the front cover. Turn the front cover so that the inside of the front case is visible.
- 3) Carefully pull outwards the clip in hooks that hold the lens holder, and remove it. CAUTION: Take care not to damage the light pipe.
- 4) Replace the lens by sliding in a new one. Make sure that the label on the lens is upright and that the smooth surface of the lens is facing outside. TAKE CARE not to leave dust or fingerprints on the lens.
- 5) Replace the clip in lens holder. NOTE: the anti-tamper fin should be on the right side. Snap in the lens holder.
- 6) Replace the front cover.

Please see FIG 2.

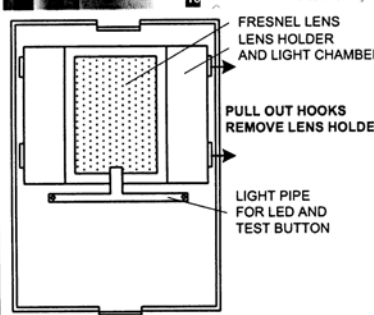

FIG 2: CHANGING THE LENS

STEP-5 SETTING THE PULSE COUNT/APS

Each PIR contains PULSE COUNT circuitry designed to adjust the sensitivity of the PIR for harsh environment. This is especially useful when locations with air drafts and possible small animals.

Set the pulse count: N=Normal (1) or H=Harsh (2)

- 1) Remove the case locking screw and remove the front cover. Look at the front of the PCB, (FIG 1).
- 2) Look for pins J2. Place a jumper on these pins if you want Low Sensitivity (Harsh). Leave open for Normal.

The APS PowerSave mode adjust to save battery power in the event that a room will be occupied for a long time, rather than send a signal constantly, draining the battery.

- 1) Look for pins J3. Place a jumper on these pins for Dynamic PowerSave mode. Leave open for regular operation.

STEP-6 VERTICAL CALIBRATION

In case that the SA-01 PIR has to be mounted at a height above (2.1m), calibrate the PCB by fixing the PCB at setting + 0.5, or +1, or +2 Depending on the extra height.

The pattern area under protection can be adjusted by sliding vertically the PCB (Printed Circuit Board) up or down inside the back case. The SA-01 is normally fitted to position 0 from the factory.

By moving the PCB up, the detection area is focused closer to the unit. (+) Moving the circuit board down increases the distance at which the unit will work most effectively.(-)

The PCB Height calibration scale is on the right hand side of the top of the PCB and the setting is done according to the line in the side of the housing.

(m)	
-4	=====
-2	=====
0	===== ←
2	=====
4	=====

13 www.rosslaresecurity.com

STEP-7 ENABLING THE BACK TAMPER

The SA-01 PIR has a built in BACK TAMPER that can detect when the sensor is removed from the wall or corner mount.

Normally the SA-01 is shipped with the BACK TAMPER disabled from the factory. To activate the back tamper follow these instructions:

- 1) Remove the Front cover of the PIR.
- 2) Unscrew the Locking Screw for the PCB, slide the PCB out. Turn the PCB over to see the micro-component side.
- 3) On the front of the PCB (See FIG 1), cut the jumper wire to activate the BACK TAMPER.
- 4) CAUTION: Take care not to damage any components or to scratch the Pyro element
- 5) Replace the PCB Back in the Plastic and Close the case. BACK TAMPER will be active.

14 www.rosslaresecurity.com

BACK TAMPER SWITCH

BACK OF PCB

(FIG 3: Back of the PCB)

15 www.rosslaresecurity.com

STEP-8 RADIO TRANSMISSION TEST

The SA-01 PIR has a built in RF TEST Function. This test is used to check the range and the reception of the sensor to the control panel receiver. If reception is poor, try to change the location of the PIR.

- 1) Ensure all of the settings in the PIR are adjusted as necessary for the location according to STEPS 1 to 6, and the PIR case is closed and locking screw is firm.
- 2) Lightly press the button on the front of the PIR for more than 3 seconds, until the LED flashes 10 times repetitively. Hold the sensor close as possible to the mounting location.
- 3) During this mode, every time the LED flashes, the sensor transmits to the panel. If the panel is armed, this will cause an alarm. If the panel is in test mode, then the signal strength can be measured
- 4) It is recommended to try several locations until the best reception is attained.

16 www.rosslaresecurity.com

STEP-9 MOUNTING THE PIR (FIG 4)

The SA-01 PIR is designed to be Mounted onto a flat wall surface and to a corner.

Flat Surface Mounting:

- 1) Remove the PCB from the back case.
- 2) Remove the knockouts from the back case labeled B by using a sharp tool or using a nail.
- 3) Affix the four screws onto the wall, so that the back tamper is pressed in.
- 4) Replace the PCB and tighten the PCB locking screw.
- 5) Replace the top cover of the PIR.

Corner Mounting:
When Enabling the Back Tamper it is necessary to use a corner mounting bracket (optional SA-02) to attach it to the corner and enable the back tamper

17 www.rosslaresecurity.com

STEP-9 MOUNTING THE PIR (FIG 4)

OPTIONAL Corner Mounting:
When Enabling the Back Tamper it is necessary to use a corner mounting bracket (OPTIONAL AS-02) to attach it to the corner and enable the back tamper.

- 1) Attach the corner bracket to the wall first, affix the 4 screws.
- 2) Remove the knock-out holes labeled A from the back case as shown in Fig 4 without removing the anti-dust adhesive.
- 3) Affix the Back Case of the PIR directly to the wall using 4 Screws.
- 4) Ensure that the BACK TAMPER arm is pressed in.

AS-02 Corner Mount Bracket

18 www.rosslaresecurity.com

INSIDE THE BACK CASE

(FIG 4: Inside the Plastic case - Back)

19 www.rosslaresecurity.com

STEP-10 WALK TEST

The SA-01 PIR has a built in WALK TEST Function. This test is used to check the Detection of the PIR and the coverage pattern adjustment. Adjust the height calibration accordingly.

- 1) Ensure all of the settings in the PIR are adjusted as necessary for the location according to STEPS 1 to 9, and the PIR is case is closed and locking screw is firm.
- 2) Lightly press the button on the front of the PIR for under 1 second. This is the walk test mode. For a period of 40 seconds the PIR will flash the LED when the pattern is crossed.
- 3) During this mode, every time the LED flashes, the sensor does not transmit. Walk across the protection area, and adjust the sensor accordingly.
- 4) It is recommended to try several walk test before concluding the setting of the PIR.

20 www.rosslaresecurity.com

L-01 Extra Wide angle Lens (Standard)

Top View

Side View

(FIG 5)

21 www.rosslaresecurity.com

L-03 Curtain Lens (Optional)

Top View

Side View

L-02 Long Range Lens (Optional)

Top View

Side View

(FIG 6)

22 www.rosslaresecurity.com

SPECIFICATIONS

Battery: 3-volt Lithium 1300 mAh, model CR123A
CAUTION! Dispose of Property, do not re-charge, disassemble, heat or incinerate.

Pulse Count: Selectable 1 or 2 by the N or H, respectively.
Installer: use N=1, H=2

Detect Range: Sensitivity: 1m 1.1°C @ 0.9 msec
(1m 2°F @ 3 ft./sec)

Operating Temp: -10°C to +50°C
(+4 °F to +122°F)

Operating Humidity: Up to 95% Non-Condensing (max.)

Alarm Transmit: 1 second

RF Frequency: Available in 433.92 or 868.35 MHz

Installation: Indoor

Lenses: Standard Wide Angle Included

Tamper Switch 1: Removal of PIR Front Cover (Protected by case tamper switch)

Tamper Switch 2: Removal of PIR from the wall or from corner mount (protected by jumper selectable rear tamper switch)

Supervisor: The supervisory signal is routinely transmitted to the panels every 20, advising the Sensor Status (1 hour in North America), Battery Status, Event Activation Status to the panel.

Current: Standby - 6µA
Transmit - 10 mA
Walk Test - 2mA

Size: 90mm x 65mm x 52mm
(3.5" x 2.5" x 2.2")

Weight: 96 grams (3.2 oz)

23 www.rosslaresecurity.com

WARRANTY

The Manufacturer's warranty on this product is for a period of one year from the date of manufacture against defects in materials and workmanship. Manufacturer's warranty hereunder is limited to repair or replacement, at the manufacturer's sole option, if the product is found to be defective in normal use during the warranty period. The warranty is given in favour of the original purchaser only. Subject to the above warranty, manufacturer's liability and that of its distributors, re-sellers and agents and is wholly limited to the original purchase price and no payment will be made for related or consequential loss including but not limited to labour costs incurred in inspection, replacement or repair of defective products. This warranty is given expressly and in place of all other expressed or implied warranties of merchantability and fitness for a particular purpose and this warranty is the only warranty made by the manufacturer. No agent, representatives or employee of the manufacturer has the authority to waive, alter or add to the printed provisions of this warranty, to make representation of warranty not contained herein or to extend this warranty to anyone other than the original purchaser of the product. The SA-01 PIR is guaranteed against defects in workmanship and material for a period of 12 (Twelve) months from date of purchase. Return the faulty product with a dated proof of purchase to your dealer for replacement.

NOTICE

The SA-01 PIR is designed to send an electronic signal to alarm control system, should intrusion occur, the warranty does not make the manufacturer or the distributor of the SA-01 PIR held liable for consequential damages resulting from any breach of warranty, expressed or implied, applicable to their use.

24 www.rosslaresecurity.com

ROSSLARE

TECHNICAL SUPPORT

U.S.A.: Rosslare Powerpath NAPDC,
North America Product Development,
22c, Howard St, # 238 Des Plaines, IL 60018, USA
Tel: (847) 827 6330 Fax: (847) 8276433

Europe: Rosslare Israel Ltd (Center Office)
22 Hamelacha St, PO BOX 11407, Rosh Ha-Ayin, 48091, Israel
Tel: (972) 3-938-6538 Fax: (972) 3-938-6830

APAC/ Middle East: Rosslare Enterprises Ltd,
905-912 Wing Fat Industrial Building
12 Wang Tai Road, Kowloon Bay, Hong Kong
Tel: (852) 2795 5630 Fax: (852) 2795 1508

E-mail: support@rosslaresecurity.com

www.rosslaresecurity.com