



ROUSH®
P E R F O R M A N C E

2015 MY

The ROUSH® Mustang

Welcome to the family! Thank you for bringing a new ROUSH® Mustang into your home. I have no doubt that this vehicle will provide you with much enjoyment for many years to come. Every time you turn the key, you will be driving your customized, one-of-a-kind ROUSH® Mustang, which will positively stand out from all the rest.

We like to say that “Between a race car and a road car... is a ROUSH® car.” What this means is that your Mustang is a blend between our racing heritage and the OEM work that we do for all the major automakers. The experience we have in engineering, manufacturing, prototyping, tooling, calibration, and all other areas are blended together to produce the ROUSH® Mustang.

This owner’s manual will cover some specifics relating to the ROUSH® content added to the Ford Mustang. If you have any questions about the vehicle, operation, or maintenance, visit www.ROUSHperformance.com or call us at **800.59.ROUSH (800.597.6874)**.

Jack Roush
USA

Jack Roush Jr.



Table of Contents

Section 1 - ROUSH® Components	3
Section 2 - Engine Maintenance Information	13
Section 3 - Vehicle Characteristics.....	17
Section 4 - Vehicle Care Suggestions.....	19
Section 5 - General Information about the ROUSH® Limited Warranty	25
Section 6 - ROUSH® Limited Warranty	29
Section 7 - How to Get Service for Non-Emissions ROUSH® Part(s).....	36
Section 8 - Federal Requirements for Emissions Warranties (ROUSHCharged® Vehicles only)	37
Section 9 - California Requirements for Emissions Warranties (ROUSHCharged® Vehicles only)	43
Section 10 - Additional Information about your Emissions Warranty Coverage, Under Federal and California Requirements.....	51
Section 11 - ROUSH®'s Warranty Coverage and Aftermarket Parts/Racing	54
Section 12 - Warranty Disclaimer and Limitation of Liability	55
Section 13 - Customer Assistance and How State Law Applies	56
Section 14 - California Proposition 65 Warning Statement.....	57
Appendix A - Vacuum Schematic	58
Appendix B - Supercharger Accessory Belt Routing Diagram	59
Appendix C - Summary Table.....	60
ROUSH® Mustang Owner Registration Card.....	61

SECTION 1 – ROUSH® COMPONENTS

The different models of the ROUSH® Mustang all have varying content. Your car may or may not include some of the following components:

ROUSHcharger® R2300 Supercharger System

From the factory, the 5.0L Ti-VCT V-8 produces 435 horsepower (hp) and 400 lb-ft of torque. Our unique system increases maximum horsepower to 670 @ 6850 RPM featuring the Eaton TVS® supercharger rotor design. This high-flowing high efficiency system moves additional air for power generation while minimizing parasitic losses. With OE-quality calibration and a ROUSH®-designed intake manifold, intercooler assembly, and higher-flow injectors, the complete system provides the increased power without losing everyday drivability.

ROUSH® Front Fascia with Aero Pockets

The 2015 ROUSH® Mustang has built upon the foundation of the new Mustang design while distinguishing itself with an aggressive design that has been refined through aerodynamic reviews, including the placement of air channeling pockets, and the relocation of the auxiliary lighting elements.

ROUSH® High-Flow Upper Grille

The High-Flow Upper Grille improves engine cooling by increasing airflow through the front grille. This grille also adds refined styling in the strong horizontal shapes in the front of the vehicle.

ROUSH® Front Chin Splitter

The ROUSH® Front Chin Splitter completes the front-end styling. Remember to use caution around speed bumps, parking blocks, and when heading down steep driveways, as damage could occur from scraping.

ROUSH® High-Flow Lower Opening

This High-Flow Lower Opening not only improves cooling by increasing airflow across the intercooler, but also adds an aggressive front appearance. Relocated auxiliary lighting elements also direct lighting right to the road.

ROUSH® Badging

Permanently mounted on the vehicle, these badges further validate the authenticity of your ROUSH® Mustang. Each ROUSH® Mustang receives both a serialized interior and under-hood badge verifying the authenticity of the vehicle, with additional front grille and decklid badges as an external identifiers. These badges are unique to your build and are only available on a full ROUSH® vehicle purchase.

ROUSH® Side Rocker Aero Aids

Extending the appearance from the ROUSH® Front Chin Splitter around the sides of the car and to the rear valance, these splitters offer an aerodynamic styling touch to dress up the bottom rockers of your car.

ROUSH® Rear Decklid Spoiler

The one-piece ROUSH® Rear Decklid Spoiler improves downforce and vehicle aesthetics. Designed from our years of motorsports experience, it is notched for improved rear visibility and has been refined with aerodynamic reviews.

ROUSH® Rear Blackout Panel

The rear ROUSH® Blackout Panel provides your ROUSH® Mustang its own rear identity signifying to all other drivers how rare your Mustang really is, complete with a bold ROUSH® badge.

ROUSH® Aero Rear Valance

The ROUSH® Aero Rear Valance provides the final styling cue that warns other drivers on the road they aren't following a regular Mustang. The shape of the diffuser also highlights the exhaust tip design and enhances the aerodynamic features.

ROUSH® Engine Coil Covers

Detailing the engine bay, ROUSH® Engine Coil Covers are available for V-8-equipped vehicles to let others know your Mustang uses only the best parts available. ROUSH Coil Covers are made of the same reinforced nylon material used in Ford's OE covers. Solvent and temperature resistant paints ensure your coil covers will keep your engine looking sharp for years to come.

ROUSH® Hood Heat Extractors

ROUSH® Hood Heat Extractors are the ultimate addition to the hood of your 2015+ Mustang GT, as they add an aggressive touch while remaining fully-functional, helping release under-hood heat away from the engine.

ROUSH® Off-Road Exhaust

ROUSH® Off-Road Exhaust systems are constructed from 304 stainless steel components to maximize system life. The exhaust tips are made from chrome-flashed 304 stainless steel for improved appearance and durability, and our exclusive muffler system gives your Mustang great sound and added performance. Due to varying state and local noise ordinances, the ROUSH® Off-Road Exhaust system is not a factory installed option. Instead, it is available for installation by the end use customer and is intended to be used in accordance with state and local noise ordinances. Vehicles with the ROUSH® Rear Diffuser are equipped with exhaust tips designed to fit the modified original equipment exhaust system.

ROUSH® Quad-Tip Exhaust System

ROUSH® Quad-Tip Exhaust Systems not only complete the look with quad exhaust tips, but also prepare the system for an upgrade to a fully-controllable exhaust sound with the ROUSH® Active Performance Exhaust upgrade.

ROUSH® Active Performance Exhaust

The first of its kind, the patent-pending ROUSH® Active Performance Exhaust system gives you the ability to choose just how loud you want to sound. Our Active Exhaust system gives you the power to change the volume of the exhaust at the tips of your fingers. Digitally controlled via mobile application or by changing switch positions, you can tailor the system from closed to fully automatic to fully open, including an option for your own custom calibration.

TRACK AND CUSTOM SETTINGS ARE FOR OFF-ROAD USE ONLY

“Dongle should only be installed for calibration purposes and not left in the vehicle permanently. Check and ensure that the installation of the WiFi dongle does not impede the physical performance of any normal driving activities. If a situation occurs in which the installed dongle protrudes too far into the under-dash area and physically impedes driving functions, you must unplug the dongle from the OBD/J1962 Connector Port and contact ROUSH® Performance for further instruction.”

ROUSH® Suspension Systems

Each ROUSH®-tuned sport suspension system offers drivers a balance between comfort and handling capability at different levels of performance specific to each vehicle application.

ROUSH® Suspension System – Coilover Adjustable-Height Damper and Spring System

An all-new system befitting of the new 2015 Mustang, the ROUSH® Coilover System has been specially-tuned utilizing lessons learned on the race track. Personally tuned by Jack Roush Jr., this coilover system draws out the best from the new chassis through improved suspension technology and tuning. Featuring custom-valved front and rear shock absorbers and rate-matched front and rear coil springs, this suspension package has been designed to blend comfort on the road and superior handling on the track. Suspension adjustment tools are provided and located inside the spare tire well.

ROUSH® Suspension System – Three-Way Coilover Adjustable-Height Damper and Spring System

The ROUSH® Three-Way Coilover Suspension System builds upon the Coilover system while allowing the highest-performance driver to uniquely tailor jounce and rebound characteristics for the track and driving techniques. Designed for optimum performance, this option optimizes the chassis dynamics for the upmost in performance.

ROUSH® 20-Inch Polished or Quicksilver Wheels with High-Performance Tires

Ultra High-Performance tires and aluminum wheels are available with either a durable polished or painted finish. This signature item on your ROUSH® Mustang catches eyes wherever you go.

ROUSH® 20-Inch Forged Wheels with High-Performance Tires

Forged dark painted wheels are available for those drivers looking to take their ROUSH® Mustang to the extreme with race-inspired wheel construction allowing for greater strength and lower weights.

ROUSH® Billet Performance Pedals

Made of quality billet aluminum and heavy-duty rubber, this high-performance pedal kit consists of an accelerator, brake, clutch (for manual transmissions), and a dead pedal. These pedals enhance both appearance and performance.

ROUSH® Front Windshield Banner

The ROUSH® Front Windshield Banner boldly displays the ROUSH® name and announces the heritage of your pony car.

ROUSH® Embroidered Floor Mats

Quality mats embroidered with the ROUSH® logo protect the carpet and keep the interior clean.

ROUSH® Graphics

Designed and produced from high-quality, OEM-grade automotive graphic materials, the coordinated color(s) will further accent your ROUSH® Mustang. Note Section 3 Vehicle Care for specific maintenance directions.

ROUSH® Locking Lug Nuts

Help protect your custom ROUSH® wheels and tires from theft with these high-quality Locking Lug Nuts which are chrome-plated for durability. A registration card is included so you can obtain a replacement key if your original is lost.

ROUSH® Instrument Gauge Cluster

Our process takes the factory instrument cluster and adds a unique ROUSH® faceplate. The ROUSH® Instrument Gauge Cluster is fully integrated with the base Ford Mustang's lighting package.

ROUSH® Leather Seating

The coordinated color trim combination accents the high-quality custom leather seat covers. ROUSH® installs new materials that grip the driver for best positioning in spirited driving while allowing for compatibility with the Ford seating heating and cooling systems.

ROUSH® RECARO Leather Seating

The RECARO seating option is an integration of racing and performance from the leader in performance vehicle seating. With ROUSH®'s RECARO Leather Seating option in your ROUSH® Mustang, you will have that integration of racing and performance along with a stylish color trim that will accent your vehicle in the best way possible.

ROUSH® 6-Speed Shift Ball

The ROUSH® Shift Ball comes in black with white accents or white with black accents. This specialized shift ball will make your Mustang stand out from the rest.

ROUSH® Door Sill Plates

These ROUSH® Door Sill Plates feature the ROUSH® wordmark. The lighted version operates in conjunction with the Ford lighting system to provide a custom look for your vehicle.

ROUSH® Quarter Window Scoops (Fastback only)

Painted black, the Quarter Window Scoops have been part of the ROUSH® Mustang DNA since 2005. This new design highlights the shape of the new Mustang while honoring the ROUSH® heritage.

ROUSH® Quarter Panel Body Side Scoops

Adding to the aggressive appearance of the ROUSH® Mustang are Quarter Panel Body Side Scoops. Positioned in front of the rear wheels, the side scoops proudly continues the style started in the first Mustang.

ROUSH® Hood Scoop

The ROUSH® Hood Scoop makes your Mustang more intimidating driving down the street or racing around the track.

ROUSH® Convertible Styling Bar (Convertible only)

This ROUSH® Styling Bar will set your car apart as it adds a unique and sporty look to your 2015+ Mustang Convertible. Mounted just behind the front seats, this Styling Bar gives your Mustang a look reminiscent of the original GT350 convertibles. The bar is constructed from 1.25-inch round steel tubing wrapped in molded foam and polyurethane hand-wrapped in OE-matching textured vinyl. This styling bar is a visual accent only and does not provide any rollover protection.

ROUSH® Trunk Mounted Tool Kit

Mounts to the underside of your trunk lid for easy access and includes several of the tools you might find handy for small jobs.

FORD Performance Parts - Rear Half Shaft Upgrade

Ford Racing-upgraded Rear Half Shafts are CNC-machined from aerospace high alloy materials and feature billet one-piece 34-spline inner and 32-spline outer stub ends. The CV joints are severe duty serviceable units with CNC billet centers making them perfect for high-stress street and race applications. Axle Half Shafts are completed in an aerospace electrically-bonded e-coating for long-lasting corrosion resistance.

SECTION 2 - ENGINE MAINTENANCE INFORMATION (Applicable to ROUSHcharged® Vehicles Only)

Before any repairs are made to your vehicle for any engine concern, please have your dealer contact ROUSH® Performance Customer Service between the hours of 8 AM and 5 PM Eastern Standard Time, Monday through Friday, at **800.59.ROUSH (800.597.6874)** for diagnostic and repair assistance. A summary list of fluid and filter specifications is provided in the Appendix section.

Your ROUSHcharged® Mustang has been uniquely calibrated by ROUSH® for proper operation of the powertrain system. This calibration program may be accidentally erased if improperly accessed by any service tool having Powertrain Control Module (PCM) flash capabilities. Instruct your service technician to contact ROUSH® before performing service to the powertrain control system. Each vehicle has the calibration assigned by VIN and are not interchangeable.

Engine Fuel

As your ROUSH® Mustang is a high-performance vehicle, it requires the use of Premium unleaded fuel of at least 91 octane (R+M/2). Do not use any type of octane booster or other fuel additives as it may cause damage to the spark plugs, catalyts, and/or other emission control devices.

Fuel Filter

Your vehicle is equipped with a lifetime fuel filter that is integrated with the fuel tank. Regular maintenance or replacement is not needed.

Engine Oil and Filter

Change your oil every 6 months or 3,000 miles, whichever occurs first, and reference the Summary Table in the Appendix for oil recommendations. This should be done more frequently if high operating temperatures are encountered, or the vehicle is run hard for extended periods such as on a racetrack. Please maintain your oil change records. The use of synthetic oils will not void your engine warranty, provided they are changed every 6 months or 3,000 miles, whichever occurs first. The oil filter should be replaced every time you change your oil.

Spark Plug Information

If equipped with a ROUSHcharger®, your ROUSH® Mustang will have ROUSH® spark plugs with a preset gap. If your plugs need to be changed, contact ROUSH® Customer Service at **800.59.ROUSH** for the correct part number. The use of a non-ROUSH® approved spark plug may damage the engine and will void your warranty.

Cooling Systems

Your ROUSH® Mustang has two separate cooling systems – one for the engine and one for the intercooler. Both use a 50/50 mix of Motorcraft Specialty Orange Engine Coolant and distilled water. This coolant mix provides both proper lubrication for the pumps in the system and anti-freeze/anti-boil protection. Consult the Ford Owner's Guide for recommended fluid replacement intervals.

Engine Coolant Fill Procedure

- 1) Fill the overflow bottle to the full line with coolant.
- 2) Operate the engine until it reaches normal operating temperature.
- 3) Check the overflow bottle and add coolant as necessary.
- 4) Re-check the overflow bottle after the engine has cooled and, if necessary, add coolant to bring the level up to the full line. Repeat steps 1 - 4 until no drop in coolant level is noted.

Intercooler Coolant Fill Procedure

Your ROUSH® Mustang is equipped with a single-core, air-to-water intercooler system with an electric water pump. This provides a cooler air charge to the cylinders, allowing your engine to develop more power.

- 1) Add coolant until it is one inch (2.54 cm) from the top of the intercooler reservoir bottle.
- 2) Turn the ignition key to the “ON” position to turn on the intercooler pump and purge any trapped air in the system. Repeat steps 1 and 2 until the reservoir stays at the full mark.

Powertrain Control Module (PCM)

The calibration values contained in the Powertrain Control Module are the exclusive property of ROUSH®, and contain highly proprietary, confidential, and trade secret information of ROUSH®. User may not copy, reverse engineer, create derivative works, transfer, loan, sell, lease, download, upload, or disclose the calibration data contained in your ROUSH® Mustang to others in any manner whatsoever. Any routine or systematic re-distribution of any portion of ROUSH®'s calibration data is expressly prohibited.

Transmission

Your ROUSH® Mustang was calibrated using factory transmission components, therefore no modifications are recommended. Refer to the Ford owner's manual for the recommended fluid replacement intervals.

Traction Control

Your ROUSH® Mustang is equipped with traction control, which can only be disabled by the operator after the vehicle is running using the instructions provided by Ford. It is primarily intended for slippery road conditions. Due to the high acceleration capability of the ROUSH® Mustang, the traction control feature could engage while accelerating at wide-open throttle.

Ford Performance Half Shafts

Wheels can loosen after initial tightening. Retighten wheel nuts within 100 mi (160 km) after a wheel is reinstalled. **WARNING:** Failure to follow this instruction may result in injury to vehicle occupant(s).

SECTION 3 - VEHICLE CHARACTERISTICS

The objective in designing our vehicle's wheel, tire, and suspension configuration was to produce a true performance machine – one meant to be driven. As such, you should know that your ROUSH® Mustang may have some characteristics that are unlike most vehicles.

These characteristics may include the following:

- A firmer ride if your ROUSH® Mustang is equipped with a ROUSH® suspension system. The ride quality is due to an engineered and balanced suspension system which improves vehicle handling. In cases where the ride height is set lower than stock, you will notice significantly less body roll, a tighter feel, and a more immediate response to your driving inputs due to a lower center of gravity.
- Less ground clearance created by the addition of suspension systems and front, side, and rear aerodynamic styling components. This is important to keep in mind when driving over rough terrains, closing in on parking blocks, or when going up or down driveways. Damage to the body styling components or suspension system may result from ground contact.
- A more aggressive sound from the tuned exhaust system. The exhaust system provides a decrease in exhaust backpressure, which increases exhaust gas flow and engine performance.

- Decreased expected tire life, which is the result of high-performance tire composition. Special tire compounds are employed which provide greater traction and speed ratings, but wear faster than conventional tires. The tires on your ROUSH® Mustang are a major part of your vehicle's ability to perform at a high level.
- The wide, low-profile tires on your vehicle have a tendency to “telegraph” road irregularities such as crowned or grooved pavement. This is not a defect in your vehicle; rather a pull or a push in your vehicle's front end may be due to road conditions.

SECTION 4 - VEHICLE CARE SUGGESTIONS

INTERIOR

To keep your ROUSH® Mustang in like-new condition, perform regular maintenance using quality materials and proper procedures. Carefully follow the manufacturer's directions when using any product, and always test cleaning products for suitability on an area that is inconspicuous. Always open your vehicle's doors or windows when you are cleaning the inside of your vehicle. NEVER use products such as gasoline or paint thinner to clean your vehicle as they are dangerous to both you and your vehicle.

Leather

Real leather is not uniform and may have scars, scratches, and wrinkles. To clean your leather, use a mild soap or leather cleaner and wipe it with a damp soft cloth. Buff the leather after cleaning with a dry, soft cloth. Regular maintenance will protect the leather and help it retain its natural beauty.

Fabric

Remove dust and loose dirt from fabric with a whisk broom or vacuum cleaner. Remove fresh spots immediately with a fabric spot cleaner.

Carpet

Vacuum the carpet frequently to remove dirt. Ground-in dirt will make the carpet wear prematurely. Use a foam-type carpet shampoo periodically to keep your carpet looking new. Follow the instructions that are supplied with the cleaner, but be careful not to oversaturate the carpet, as it may take an excessive amount of time to dry.

EXTERIOR

Washing

To protect your vehicle's exterior finish and graphic decals (if applicable), it is important to wash your vehicle often. Industrial fallout, road tar, bird droppings, tree sap, and other foreign matter can damage the finish on your vehicle.

Generally, the longer the material remains in contact with the exterior finish or graphic decals, the more extensive the damage that can occur. Damage that results from these and similar conditions is not covered under your vehicle's warranty, so care should be taken to inspect and keep your exterior clean.

Wash your vehicle as soon as possible when it becomes dirty. Do not wash your vehicle in direct sunlight, but rather park in a shady area. Before washing, rinse your vehicle with clean water to remove any surface contamination. Next, wash the vehicle from top to bottom using a soft sponge or wash mitt with a mild vehicle wash soap. Finally, rinse the vehicle thoroughly and wipe it dry with a soft towel or chamois. To complete the job, carefully clean the door jambs

and joints between the doors, hood, and trunk of your vehicle with a damp cloth. Never wipe a dry surface, as fine scratches in your paint will result.

ROUSH® recommends hand washing your vehicle. Please be aware that automatic car washes can damage the vehicle in a number of ways; often the tire tracks used are too high and could damage the body components, or are too narrow for the ROUSH® wheels; the washing elements and rotating brushes can snag or catch on body components or accessories (such as window louvers) and pull them off, or scratch the paint (which is especially visible on darker paint colors). If your Mustang is equipped with decals, such as stripes, do not use a commercial or high-pressure wand on the striped surfaces or stripe edges. Damage resulting from an automatic car wash or high-pressure wand is not covered under your warranty.

Some Other Suggestions:

Some types of car washes apply both high pressure and high temperatures to the vehicle, which can result in heat distortion and loosening of the body styling components on the vehicle body. Therefore, be sure to observe the following precautions:

- Maintain a minimum distance of approximately 16 inches (40 cm) between the vehicle body and the wash nozzle.
- When washing around the door glass, increase the distance to 40 inches (1m) and spray at right angles to the glass surface.

Waxing

ROUSH® recommends that you wax your vehicle at least twice a year, or when painted surfaces do not shed water well. Make sure your vehicle is clean and dry before waxing. As with washing, do not apply wax in direct sunlight.

Normal wear and tear may result in your vehicle's finish having some minor scratches or chips. Many times minor scratches can be removed with a fine polishing compound available at your local automotive store. Chips can be touched up with paint readily available from your local Ford dealer. Your vehicle's paint color is noted on your driver's door label installed by Ford at the time of manufacture. Use a high-quality wax and hand-apply only if you choose to wax the decals on your vehicle; a wheel could snag or tear the decals. Never apply wax to any matte finish decals as it could cause permanent discoloration and damage.

Body Styling Components

Use a sponge or soft towel with warm, soapy water to clean these parts. As these components are not metal, do not use a scrub brush or rubbing compound on them as it may damage the part and/or finish. Also, be careful not to bring these parts in contact with brake fluids, wheel cleaners, or other such products which can stain, crack, or discolor them. If these substances do come in contact, immediately rinse the affected part(s) with clear, clean water.

Wheel Care

Regular cleaning of your wheels with mild soap and water is recommended to protect your investment in the high-quality ROUSH wheels. Use of chemical cleaners may adversely affect the finish of the wheels, resulting in shorter life span or damaged coatings. Due to the variety of cleaning products available on the market, only mild soap and water is recommended for regular cleanings to maintain the finish of the wheels. Use of cleaners other than soap and water will void your warranty.

Tires

The proper wheel and tire combination is basic to every performance vehicle. Tire pressures should be checked at least once a month and adjusted if needed. Keeping your tires properly inflated will provide you with the best combination of handling, tread life, and ride comfort. Inflation pressures are always a “cold inflation pressure,” which is measured after the vehicle has been sitting for a minimum of three hours. The recommended tire pressure for your ROUSH® Mustang can be found on a sticker on the driver’s side door jamb.

Tire Maintenance

- Check your tire pressure on a regular basis. Under-inflated tires wear unevenly, alter the handling, and are more likely to fail from overheating. Over-inflated tires also wear improperly, contribute to a harsh ride, and are prone to damage from road hazards. The correct tire pressure ratings for your ROUSH® Mustang are located on a label located on the driver’s side door jamb.

Tire Replacement

If you replace your vehicle's tires, make sure the size (aspect ratio) and load rating match the tires supplied with your vehicle because speedometer, odometer, and ABS brake operation are based on these factors. The use of tires larger than originally supplied may interfere with operation of these components and possibly cause vehicle damage. Smaller tires may not properly seat on the wheels, causing a dangerous operating condition. We recommend purchasing replacement tires identical to those on your new vehicle. See your dealer or contact us at **800.59.ROUSH (800-597-6874)**.

- Maintain wheel balance and front end alignment. Balance concerns are usually noted as a general vibration throughout the vehicle, while alignment concerns manifest themselves as the vehicle pulling either to the right or left. If these conditions exist, contact your dealer for service.
- Rotate your tires in accordance with the recommendations in your Ford Owner's Manual to maximize their life. Some of the tires offered on the ROUSH® Mustang are directional and cannot be rotated from side to side, only front to back. If you have any questions regarding tire rotation on your vehicle, contact your dealer.

Spare Tire Usage

If the vehicle is equipped with a spare tire, it can be used as stated in the Ford Owner's Manual.

SECTION 5 - GENERAL INFORMATION ABOUT THE ROUSH® LIMITED WARRANTY

ROUSH® is proud to offer you one of the most comprehensive warranties in the performance business, which is subject to certain limitations and disclaimers further identified below.

This section provides an overview of the ROUSH® Limited Warranty. For specific details, you can refer to the ROUSH® Limited Warranty Section below, the ROUSH® warranty card in your vehicle, or contact your authorized Ford Dealer who sells ROUSH® vehicles. We also offer a toll-free customer service number for any consumer questions. You can reach us between the hours of 8 AM and 5 PM Eastern Standard Time, Monday through Friday, at **800.59.ROUSH (800.597.6874)**.

Maintain Your Vehicle Properly

Your glove box contains a Ford Schedule Maintenance Guide for reference and recording maintenance work performed on your vehicle. Proper vehicle maintenance is the sole responsibility of the vehicle owner. ROUSH® Performance Products and/or Ford Motor Company may deny you warranty coverage if you fail to keep records and receipts that verify vehicle maintenance specified in the Ford Schedule Maintenance Guide has been performed.

When Does Your ROUSH® Warranty Begin?

Your ROUSH® warranty begins either the day you take delivery of your new vehicle or the day it is first put into service (for example, as a dealer demonstrator), whichever occurs first. The vehicle's original in-service date or warranty start date (W.S.D.) is determined by Ford dealer OASIS (On-Line Service Information System) report. Should you ever require warranty repairs to any ROUSH® part on your vehicle, we recommend that you take your vehicle to an authorized Ford Dealer that sells ROUSH® vehicles for service.

Who Pays For ROUSH® Warranty Repairs?

You will not be charged for covered warranty repairs made during the warranty periods identified in the ROUSH® Limited Warranty for those ROUSH® parts installed by ROUSH®. All initial warranty claims are processed through your dealer and the ROUSH® Performance corporate office in Plymouth, Michigan, regardless of where the vehicle was purchased.

Vehicle Service

ROUSH® has authorized specific Ford Dealers to sell and service our vehicles. In case a service need arises, we suggest you contact your selling Ford Dealer for service, who wants to ensure your continued satisfaction. If this is not possible, you may take your vehicle to any authorized Ford Dealer that sells ROUSH® vehicles for service. If you have a warranty claim, please contact your local Ford dealer that sells ROUSH® vehicles or contact ROUSH® Performance Customer Service between 8 AM and 5 PM Eastern Time, Monday through Friday, at **800.59. ROUSH (800.597.6874)**. Please have the vehicle identification number (V.I.N.) available.

Emergency Repairs

If you encounter an emergency where neither an authorized Ford Dealer that sells ROUSH® vehicles, nor any authorized Ford Dealer is available to repair your vehicle and you must have repairs made by someone else, ROUSH® may reimburse you for the cost of repairs (within reason) and with prior approval from ROUSH®. Be sure to obtain the parts that were replaced along with a receipt for the repairs. Present both to your local authorized Ford Dealer that sells ROUSH® vehicles, who will work with ROUSH® to determine if the repair is warrantable and reimbursement is justified.

Customer Service

Customer satisfaction is a primary objective of ROUSH®, and we make every attempt to ensure that our owners are satisfied. We recognize the importance of retaining customer confidence in us after the purchase, and rely on those Ford Dealers that sell ROUSH® vehicles to maintain effective customer relations.

If you have any questions or issues relating to your ROUSH® vehicle, we suggest you follow these steps:

- 1) First, contact your selling Ford Dealership salesperson or service advisor.
- 2) If your concerns remain unresolved after Step 1, please contact the dealership's Sales Manager or Service Manager.
- 3) If you are still unable to resolve your concern, please feel free to contact ROUSH® Performance Customer Service between the hours of 8 AM and 5 PM Eastern Standard Time, Monday through Friday, at **800.59.ROUSH (800.597.6874)**. A ROUSH® representative will assist you in resolving your concern.

Production Changes

ROUSH® and those authorized Ford dealers that sell ROUSH® vehicles reserve the right to make changes in vehicles at any time without incurring any obligation to make the same or similar changes on vehicles previously built or sold.

Does The ROUSH® Warranty Apply In Other Countries?

The ROUSH® Limited Warranty described here applies to your vehicle if:

- It was originally sold or leased by a Ford dealer in the United States or U.S. Federalized Territories that sells ROUSH® Performance Products, and it was originally registered/licensed and operated in the United States, U.S. Federalized Territories, or Canada; or
- It was originally purchased through the Ford Export Operations Military Sales Program.

If you meet either of these two requirements, you have ROUSH® warranty coverage when you travel with your vehicle outside of the United States or Canada. In some cases, you may have to pay the servicing authorized Ford Dealer in a foreign country for a repair that is covered under the ROUSH® warranty. If this occurs, be sure to save the paid repair order or invoice. For refund consideration, you should present your receipt to your U.S. or Canada authorized Ford dealer that sells and services ROUSH® vehicles.

SECTION 6 - ROUSH LIMITED WARRANTY

WHO IS COVERED

The vehicle is covered for the original purchaser of a new, genuine ROUSH® vehicle that has been upfitted by the ROUSH® factory with genuine ROUSH® parts and components (individually and collectively called “ROUSH® Part(s)”) and purchased from an authorized Ford Dealer that sells ROUSH® vehicles. This Limited Warranty is transferable from the original purchaser to subsequent owners within the warranty period. The term “ROUSH® Part(s)” as used in this Limited Warranty includes all ROUSH®-installed parts and components on the vehicle, unless the part is separately called out in this warranty.

WARRANTY PERIOD AND COVERAGE FOR NON-EMISSION ROUSH® PART(S)

The warranty period for ROUSH® Part(s) (other than emissions-related ROUSH® Part(s)) will be the first to occur of **3 years or 36,000 miles**; subject to the limitations of coverage and exclusions identified below. The **Warranty Start Date** is determined by the Ford dealer OASIS (On-Line Service Information System) report (as stated in Section 5 - “When Does Your Warranty Begin”).

When installed, ROUSH® Part(s) will void the Ford warranty as it pertains to that specific part or component (i.e., a ROUSH® suspension package will only void the Ford suspension warranty). The ROUSH® warranty only covers defects in materials and workmanship of ROUSH® Part(s) and their installation, from the date and mileage your vehicle is first put into service. During the warranty period ROUSH® will in its sole discretion repair, replace, or adjust

any defective ROUSH® Part(s) on the vehicle or other substantially damaged areas on the vehicle that arise as a direct result of interaction with the defective ROUSH® Part(s). A replaced ROUSH® Part(s) or component assumes the remaining warranty of the original replaced. ROUSH® reserves the right to improve or modify any ROUSH® Part(s) without assuming any obligation to update or replace any previously manufactured and installed ROUSH® Part(s).

LIMITATION OF COVERAGE

Alignment. ROUSH® will provide reimbursement for one front-end alignment under warranty during the first 12 months or 12,000 miles, whichever occurs first, on vehicles that ROUSH® has installed our suspension system. ROUSH® requires a before-and-after alignment printout to accompany the service invoice.

Wheel Balancing. Wheel and tire assemblies are balanced by ROUSH® and typically will not require adjustment. If balancing is needed, ROUSH® will pay for one wheel balance on each tire during the first 12 months or 12,000 miles, whichever occurs first.

Tires. The tires fitted to your ROUSH® wheels are separately warranted by the tire manufacturer, which is included in the owner literature that came with your vehicle. If the tire warranty information is not in your owner's literature, call the tire manufacturer directly to request information. If a tire is damaged during the warranty period as a result of a ROUSH® Part(s), ROUSH® will replace the tire on a pro-rated mileage basis.

ROUSH® Painted Body Components. Paint concerns that are cosmetic in nature, such as runs, fisheyes, and similar situations are warranted for 12 months or 12,000 miles, whichever occurs first.

ROUSHcharger®. If your new Mustang is equipped with a ROUSHcharger®, the warranty coverage is subject to the following limitations:

ENGINE COMPONENTS COVERED:

All internal lubricated parts, cylinder block, cylinder heads, electric fuel pump, electronic engine control unit, engine mounts, flywheel, manifold (exhaust and intake), manifold bolts, oil pan, oil pump, seals and gaskets, thermostat, thermostat housing, timing chain cover, timing chain (gears or belt), supercharger unit, valve covers, and water pump. If a failure of any of the above parts damages either the engine block or cylinder heads, a remanufactured long block assembly will be provided.

TRANSMISSION COMPONENTS COVERED:

All internal parts, clutch cover, seals and gaskets, transmission case, and transmission mounts.

REAR AXLE COMPONENTS COVERED:

Axle shafts, bearings (front and rear), center support bearing, drive axle housing (including all internal parts), drive shaft, propeller shafts, retainers, supports, seals and gaskets, universal and constant velocity joints.

WHAT IS NOT COVERED?

The following circumstances are intended to parallel standard Ford warranty exclusions and are not covered by this warranty, including but not limited to:

- Abnormal operation, road hazards, misuse, abuse, neglect, accidents, collision, fire, theft, freezing, vandalism, riot, explosion, or objects striking the vehicle;
- Participating in or preparation of the vehicle for racing or other high-performance driving activity (on a track or otherwise), including but not limited to competition driving, participation in timed driving events, and performance driving school training or practice;
- Misusing the vehicle, such as driving over curbs, overloading, racing, or using the vehicle as a stationary power source;
- Altering, disassembling, or modifying the ROUSH® Part(s) after the vehicle leaves the Ford Dealer's or ROUSH®'s control;
- Tampering with the vehicle or with other parts (OEM or ROUSH®) that affect the ROUSH® Part(s) including without limitation, the emissions systems or the other parts that affect these systems;
- Defects caused or induced by failures, breakdowns, or damage by other parts, components, or the vehicle;
- Vehicle recall or service campaign warranty claims negotiable on an incident-by-incident basis;
- Subjecting the ROUSH® Part(s) to excess moisture or water or any motor vehicle fluids (e.g. oil, anti-freeze, battery acid, brake fluid, etc.) or driving through water deep enough to cause water to be ingested into the engine;

- Acts of God, acts of war or terrorism, natural disasters, and other similar causes beyond the reasonable control of ROUSH®;
- Application of chemicals that affect the ROUSH® Part(s) including, without limitation, caustic (acid based) cleaners on chrome, coated, or finished surfaces;
- Lack of maintenance or lack of fluids;
- Failure to follow recommended maintenance of the ROUSH® Part(s) including without limitation periodic cleaning and polishing;
- Damage resulting from a collision (including operation of such an impaired vehicle will void this warranty), owner is responsible for ensuring no further damage occurs once damage has occurred;
- Valve replacement on ROUSH® wheels and using proper weights on ROUSH® chrome wheels;
- Using improperly-sized tires on the ROUSH® wheels that are not in accordance with standards recommended by ROUSH® or the Tire and Rim Association;
- Inflating the tires on the ROUSH® wheels beyond the maximum or below the minimum air pressure as specified by the tire manufacturer;
- Altering, modifying, or subjecting the ROUSH® wheels to processing such as heating, welding, straightening, or machining;
- Brake pads or other items that would be consumed in the course of driving the vehicle; and Installation or modification with aftermarket components including ROUSH® Retail Performance Parts may void the Powertrain Warranty

This warranty does not cover surface deterioration of paint, finish, trim, and appearance items on any ROUSH® Part(s) that result from use and/or exposure to the elements such as stone chips, bird droppings, lightning, hail, windstorm, dings, dents, earthquake, road salt, brake dust, trees (sap, leaves, berries, etc.), water or flood, surface corrosion, damage, chips, dents, scratches, customer neglect, or normal wear and tear.

For vehicles upfitted with a ROUSHcharger®, in addition to the points noted above under “What is Not Covered”, the following are NOT COVERED by this warranty for the ROUSHcharger®:

Engine components specifically not listed as “COVERED” under the ROUSHcharger® section found under “Limitation of Coverage”, including, but not limited to parts, filters, etc., that are required to be replaced as a part of a normal vehicle maintenance schedule.

Failure of related parts external to the transmission that causes a transmission claim including, but not limited to, transmission coolers, levers, controls, etc., will void coverage under this warranty.

Installation or modification with aftermarket components including ROUSH® Retail Parts may void the Powertrain Warranty.

Further, this warranty **DOES NOT COVER** the original equipment manufacturer (OEM) exterior engine components, ignition, fuel system, or damage related to or arising from:

- a) Use of fuel with octane rating less than 91 (r+m)/2 (requires Premium Fuel), or contaminated fuel.
- b) The use of non-ROUSH®-approved accessories, such as, headers, air induction, fuel additives (i.e. Octane booster), camshafts, nitrous oxide systems, rear end modifications, remanufactured components, or engines unauthorized by ROUSH® or OEM, and other aftermarket products.
- c) Damage or abuse related to overloading, PCM recalibration, misuse, negligence, road conditions, and other non-ROUSH® approved modifications.

MAINTENANCE/WEAR

The ROUSH® Limited Warranty does not cover: (1) parts and labor needed to maintain the vehicle; and (2) the replacement of parts due to normal wear and tear. You, as the owner, are responsible for these items. Some examples of maintenance and normal wear are:

- Oil changes
- Oils, lubricants, and other fluids
- Oil/air filters
- Cleaning/polishing
- Clutch linings
- Wiper blades
- Tire rotation/inflation

SECTION 7 - HOW TO GET SERVICE FOR NON- EMISSIONS ROUSH® PART(S)

For warranty service, ROUSH® recommends that you bring your vehicle to an authorized Ford Dealer that sells ROUSH® vehicles, or if one is not available, to any authorized Ford Dealer. The dealer will review and submit all claims for defects in, or damage arising from ROUSH® Part(s) or their faulty installation. ROUSH® will promptly assess the claim and make a determination regarding the claim. To the extent Ford's warranty is involved, the final action will be determined by a combined analysis by the Ford Dealer, Ford Motor Company, and a ROUSH® Performance representative. The Ford Dealer must receive ROUSH®'s written authorization before beginning any work to be billed to ROUSH®.

ROUSH® reserves the right to transport your vehicle to the ROUSH® factory for any repair, replacement, or adjustment of ROUSH® Part(s). However, ROUSH®'s warranty **does not** cover the cost of rental cars or towing during the performance of any such repair, replacement, or adjustment service, whether performed at ROUSH®'s factory or a Ford Dealership.

For further information about ROUSH® Performance vehicles and products, call us between the hours of 8 AM and 5 PM Eastern Standard Time, Monday through Friday, at **800.59.ROUSH (800.597.6874)**, or locate us on the World Wide Web at **www.ROUSHperformance.com**.

SECTION 8 - FEDERAL REQUIREMENTS FOR EMISSIONS WARRANTIES (ROUSHCHARGED® VEHICLES ONLY)

QUICK REFERENCE: EMISSIONS WARRANTY COVERAGE FOR THOSE VEHICLES EQUIPPED WITH A ROUSHCHARGER® INSTALLED BY ROUSH® PERFORMANCE

If your vehicle is equipped with a ROUSHcharger® installed by ROUSH®, the following two warranties apply to your vehicle in accordance with Federal requirements. The warranties are:

- **EMISSIONS DEFECTS WARRANTY**
- **EMISSIONS PERFORMANCE WARRANTY**

EMISSIONS WARRANTIES FOR YOUR VEHICLE

For full details on emissions control coverage, see:

- EMISSIONS DEFECT WARRANTY, Page 38
- EMISSIONS PERFORMANCE WARRANTY, Pages 38-39**
- WHAT IS COVERED? Pages 40-41
- WHAT IS NOT COVERED? Page 42

EMISSIONS DEFECT WARRANTY COVERAGE

During the warranty coverage period, ROUSH® warrants that:

- Your vehicle or engine is designed, built, and equipped to meet, at the time it is sold, the emissions regulations of the U.S. Environmental Protection Agency (EPA)
- Your vehicle or engine is free from emission-related defects in factory-supplied materials or workmanship that could prevent it from conforming to applicable EPA regulations.
- You will not be charged for diagnosis, repair, replacement, or adjustment of parts containing an emissions related defect. Applicable parts are listed under “WHAT IS COVERED?” on pages 40-41.

The warranty coverage period for passenger cars and light duty trucks with a gross vehicle weight rating of 8,500 lbs. or less:

- 8 years or 80,000 miles (whichever occurs first) for catalytic converters, electronic emissions engine control unit (ECU), and onboard emissions diagnostic module;
- 3 years or 36,000 miles (whichever occurs first) for all other covered parts. See WHAT IS COVERED? For list of covered parts on pages 40-41.

EMISSIONS PERFORMANCE WARRANTY COVERAGE

Under Emissions Performance Warranty coverage, ROUSH® will repair, replace, or adjust, with no charge for labor, diagnosis, or parts, any emissions control device or system, if you meet all of the following conditions:

- You have maintained and operated your vehicle according to the instructions on proper care identified in the Ford Owner's Guide, the Ford Schedule Maintenance Guide, and this ROUSH® Owner's Guide Supplement.
- Your vehicle fails to conform, during the warranty coverage period, to the applicable national EPA standards, as determined by an EPA approved inspection and maintenance program.
- You are subject to a penalty or sanction under local, state, or federal law because your vehicle has failed to conform to the emissions standards. (A penalty or sanction can include being denied the right to use your vehicle.)
- Your vehicle has not been tampered with, misused, or abused.

The warranty coverage period for passenger cars and light duty trucks with a gross vehicle weight rating of 8,500 lbs. or less:

- 8 years or 80,000 miles (whichever comes first) for catalytic converters, electronic emissions control unit (ECU), and onboard emissions diagnostic devices;

See **WHAT IS COVERED?** For list of covered parts on pages 40-41.

NOTE: The warranty period begins on the **Warranty Start Date** as specified on page 26 of this booklet.

WHAT IS COVERED?

These parts are covered by both the Emissions Defect Warranty and the Emission Performance Warranty.

LIST OF PARTS COVERED BY EMISSIONS WARRANTIES FOR CARS AND LIGHT DUTY TRUCKS.

- Air Flow Sensor
- Air/Fuel Feedback Control System and Sensors
- Air Induction System
- Catalytic Converters
- Electronic Engine Control Sensors and Switches
- Powertrain Control Module (PCM)
- Evaporative Emissions Control System
- Exhaust Gas Recirculation (EGR System)
- Exhaust Heat Control Valve
- Exhaust Manifold
- Exhaust Pipe (Manifold to Catalyst)
- Fuel Filler and Neck Restrictor
- Fuel Injection System
- Fuel Injector Supply Manifold
- Fuel Tank

- Fuel Tank Pressure Control Valve
- Idle Air Bypass Valve
- Ignition Coil and/or Control Module
- Intake Manifold
- Malfunction Indicator Lamp (MIL) - On-Board Diagnostic (OBD) System
- PCV System and Oil Filler Cap
- Secondary Air Injection System
- Spark Control Components
- Spark Plugs and Ignition Wires
- Thermostat
- Throttle Body Assembly (MFI)
- Transmission Control Module (TCM) and Solenoids
- Vacuum Distribution System

IMPORTANT INFORMATION ABOUT LIST OF PARTS

Also covered by the two emissions warranties are all emissions-related bulbs, hoses, clamps, brackets, tubes, gaskets, seals, belts, connectors, non-diesel fuel lines, sensors, and wiring harnesses that are used with components on the above list of parts.

Concerning parts that should be replaced on a certain maintenance schedule: these parts remain under warranty until: (a) the first replacement time that is specified in your Ford Owner's Guide, the Ford Scheduled Maintenance Guide and this ROUSH® Owners Guide Supplement; or (b) the time or mileage limits of the Federal Defect and Performance Warranties (whichever occurs first). Your authorized Ford Dealer that sells ROUSH® vehicles maintains a complete list of parts covered by emissions warranties. For more detail about the specific parts covered by the Emissions Defect Warranty, contact ROUSH® Performance Customer Service between the hours of 8 AM and 5 PM Eastern Standard Time, Monday through Friday, at **800.59.ROUSH (800.597.6874)**.

WHAT IS NOT COVERED?

ROUSH® may deny you warranty coverage if your vehicle or part has failed because of abuse, neglect, improper maintenance, unapproved modifications, or any items included in WHAT IS NOT COVERED? on pages 32-35.

If you require more information about getting service under the Federal Emissions Performance Warranty, or if you want to report what you believe to be a violation of the terms of this warranty, you may contact:

Manager, Certification and Compliance Division (6405J)
Warranty Claims Environmental Protection Agency
Ariel Rios Building
1200 Pennsylvania Avenue, N.W.
Washington, D.C. 20460

SECTION 9 - CALIFORNIA REQUIREMENTS FOR EMISSIONS WARRANTIES (ROUSHCHARGED® VEHICLES ONLY)

VEHICLES ELIGIBLE FOR CALIFORNIA EMISSION WARRANTY COVERAGE

California emission warranty coverage applies if your vehicle meets the following two requirements:

- 1) Your vehicle is registered in California or other states* adopting California emission and warranty regulations,
- 2) Your vehicle is certified for sale in California as indicated on the vehicle emission control information label.

* Other states adopting California emissions and warranty regulation (Passenger Car & Light Trucks up to 8500 lbs GVWR) may include but subject to change – California, Connecticut, Delaware, Maine, Maryland, Massachusetts, New Jersey, New York, Oregon, Pennsylvania, Rhode Island, Vermont, and Washington. (NOTE: New York adopted California emissions standards, but not the California Emissions Warranty; the Federal Emission Control Warranty applies to all non-PZEV vehicles in New York).

EMISSIONS WARRANTIES FOR CALIFORNIA CERTIFIED VEHICLES

For full details about coverage under California requirements for emissions control, see:

- Defects Warranties (Page 44**)
- Performance Warranty (Page 44**)
- What Is Covered? (Pages 47-48)
- What Is Not Covered? (Page 50**)

EXPLANATION OF CALIFORNIA EMISSIONS WARRANTIES

YOUR WARRANTY RIGHTS AND OBLIGATIONS

The California Air Resources Board and ROUSH® Performance Products, Inc. are pleased to explain the emission control system warranty on your new vehicle. In California, new motor vehicles must be designated, built, and equipped to meet the State's stringent anti-smog standards. ROUSH® must warrant the emission control system on your vehicle for the periods of time listed on page 43**, provided there has been no abuse, neglect, or improper maintenance of your vehicle.

Your emission control system may include parts such as the carburetor or fuel injection system, the ignition system, catalytic converter, and the engine computer. Also included may be hoses, belts, connectors, and other emissions-related assemblies.

Where a warrantable condition exists, ROUSH® or its suppliers will repair your vehicle at no cost to you including diagnosis, parts, and labor.

ROUSH'S WARRANTY COVERAGE

For 3 years or 50,000 miles (whichever occurs first)

1. If your vehicle fails a Smog Check inspection, all necessary repairs and adjustments will be made by ROUSH® or its suppliers to ensure that your vehicle passes the inspection. This is your emission control system PERFORMANCE WARRANTY.
2. If any emissions-related part on your vehicle is defective, the part will be repaired or replaced by ROUSH® or its suppliers. This is your short-term emission control system DEFECTS WARRANTY.

For 7 years or 70,000 miles (whichever occurs first)

1. If an emissions-related part listed on pages 40-41** with coverage for 7 years or 70,000 miles is defective, the part will be repaired or replaced by ROUSH® or its suppliers. This is your long-term emission control system DEFECTS WARRANTY.

OWNER'S WARRANTY RESPONSIBILITIES

As the vehicle owner, you are responsible for the performance of the required maintenance identified in the Ford

Schedule Maintenance Guide and this ROUSH® Owner's Guide Supplement provided with your vehicle. ROUSH® recommends that you retain all receipts covering maintenance on your vehicle, but ROUSH® cannot deny warranty coverage solely for lack of receipts or for your failure to ensure the performance of all scheduled maintenance.

You are responsible for presenting your vehicle to an authorized Ford Dealer that sells ROUSH® vehicles as soon as a problem exists. The warranty repairs should be completed within a reasonable amount of time, not to exceed 30 days.

As the vehicle owner, you should also be aware that ROUSH® may deny you warranty coverage if your vehicle or a part has failed due to abuse, neglect, improper maintenance, or unapproved modifications.

If you have any questions regarding your warranty rights and responsibilities, or if you want to report what you believe to be a violation of the terms of this warranty, you may contact ROUSH® Performance Customer Service between the hours of 8 AM and 5 PM Eastern Standard Time, Monday through Friday, at **800.59.ROUSH (800.597.6874)** or the California Air Resources Board at:

State of California Air Resources Board Mobile Source Operations Division
P.O. Box 8001
El Monte, California 91731-2990

WHAT IS COVERED?

If the parts on the following list contain a defect that affects emissions, they are covered by the DEFECTS WARRANTIES.

- Air Flow Sensor
- Air/Fuel Feedback Control System and Sensors
- Air Induction System
- Catalytic Converters
- Electronic Engine Control Sensors and Switches
- Powertrain Control Module (PCM)/Engine Control Module (ECM)
- Evaporative Emission Control System
- Electronic Ignition System
- Exhaust Gas Recirculation (EGR) System
- Exhaust Manifold
- Exhaust Pipe (Manifold to Catalyst)
- Fuel Filler Tube and Seal (non-diesel only)
- Fuel Injection System
- Fuel Injector Supply Manifold
- Fuel Tank

- Fuel Tank Pressure Control Valve
- Idle Air Bypass Valve
- Ignition Coil and/or Control Module
- Intake Manifold
- Intercooler Assembly – Engine Charger
- Malfunction Indicator Lamp (MIL)/On-Board Diagnostic (OBD) System
- PCV System and Oil Filler Cap
- Secondary Air Injection System
- Spark Control Components
- Spark Plugs and Ignition Wires
- Thermostat
- Throttle Body Assembly (MFI)
- Transmission Control Module (TCM) and Solenoids
- Turbocharger Assembly
- Vacuum Distribution System

****COVERAGE FOR VEHICLES HAVING A GROSS VEHICLE RATE RATING OF 14,000 LBS. OR LESS.**

(Coverage for Up to 7 years/70,000 miles, whichever first occurs)

Cam Timing Assembly Catalytic Converter Fuel Tank

Intake Manifold Exhaust Manifolds

Powertrain Engine Control Unit (ECU) Powertrain Control Wiring Harness

Dash Panel and Headlamp Junction Wiring Assembly (1)

(1) For MIL illumination only

IMPORTANT INFORMATION ABOUT LIST OF PARTS

Also covered by this warranty are all emissions-related bulbs, hoses, clamps, brackets, tubes, gaskets, seals, belts, connectors, non-diesel fuel lines, and wiring harnesses that are used with components on the above list of parts.

Concerning parts that should be replaced on a certain maintenance schedule, these parts remain under warranty until the first replacement time that is specified in your Ford Owner's Guide, the Ford Scheduled Maintenance Guide, and this ROUSH® Owner's Guide Supplement.

NOTE: If the diagnosis does not reveal a defect, the Defects Warranty does not apply.

Your authorized Ford Dealer that sells ROUSH® vehicles maintains a complete list of covered parts. For more detail about the specific parts covered by the Defects Warranty, contact ROUSH® Performance Customer Service between the hours of 8 AM and 5 PM Eastern Standard Time, Monday through Friday, at **800.59.ROUSH (800.597.6874)**.

WHAT IS NOT COVERED?

ROUSH® may deny you warranty coverage if your vehicle or part has failed because of abuse, neglect, improper maintenance, unapproved modifications, or any items included in WHAT IS NOT COVERED? on pages 32-35.

SECTION 10 - ADDITIONAL INFORMATION ABOUT YOUR EMISSIONS WARRANTY COVERAGE, UNDER FEDERAL AND CALIFORNIA REQUIREMENTS

HOW DO I GET WARRANTY SERVICE?

To get service under your emissions warranties, we recommend that you take your vehicle to an authorized Ford Dealer that sells ROUSH® vehicles or, if none is available, any authorized Ford Dealer as soon as possible after illumination of the Malfunction Indicator Light or it has failed an EPA-Approved test or a California Smog Check inspection. You must provide the dealer the document that says your vehicle has failed the test.

The Ford Dealer will determine whether the repair is covered by the warranty. If the dealer has a question about Emissions Performance Warranty coverage, it will forward the question to ROUSH®, which must make a final decision within 30 days after you bring your vehicle in for repair (the decision will be made within a shorter time if state, local, or federal law requires you to have the vehicle repaired more quickly in order to avoid additional penalties). The deadline for a determination about Emission Performance Warranty coverage does not need to be met if you request a delay, agree to a delay in writing or if the delay is caused by an event for which neither the Ford Dealer nor ROUSH® is responsible. If a question about Emissions Performance Warranty coverage is referred to ROUSH®, you will be notified by ROUSH® in writing if your claim for warranty coverage is denied. The notice will explain the basis for denying your claim. If you fail to receive this notice within a timely manner, as determined above, ROUSH® will perform the warranty repair for you free of charge.

HOW DO I HANDLE EMERGENCY REPAIRS?

If your vehicle needs an emergency warrantable repair and an authorized Ford Dealer that sells ROUSH® vehicles or any other Ford Dealer is not available, or if the Ford Dealer cannot perform warrantable repair(s) within 30 days of you bringing your vehicle to the dealership, repairs may be performed at any service establishment or by you using Ford or ROUSH® equivalent replacement parts.

ROUSH® will reimburse you for the cost of these warranty repairs including diagnosis, if you take the part(s) that are replaced and the repair receipt(s) to any authorized Ford Dealer that sells ROUSH® vehicles. The reimbursement will not exceed ROUSH® Performance's or Ford Motor Company's suggested retail price for the warranted parts that are replaced and labor charges based on Ford's or ROUSH®'s recommended time allowance for the warranty repair and the geographically appropriate standard labor rate.

WHAT REPLACEMENT PARTS SHOULD I USE?

ROUSH® recommends that you use genuine Ford and ROUSH® replacement parts. However, when you are having non-warranty work performed on your vehicle, you may choose to use non-Ford or non-ROUSH® Part(s). If you decide to use non-Ford or non-ROUSH® Part(s), be sure they are equivalent to the Ford or ROUSH® Part(s) in performance, quality, and durability. If you use replacement parts that are not equivalent to Ford parts or ROUSH® Part(s), your vehicle's emissions control system may not work as effectively, and you may jeopardize your emissions warranty coverage.

For vehicles within the warranty period, ROUSH® will repair at no cost to the owner, under the Federal Emissions Warranty, covered emissions failures caused by properly installed Ford or ROUSH® Part(s) or non-Ford or non-ROUSH® Part(s) that have been certified by the U.S. Environmental Protection Agency (EPA). ROUSH® is not responsible for the cost of repairing any emission failures caused by non-Ford or non-ROUSH® Part(s) that have not been certified by the EPA.

The maintenance, replacement, or repair of emissions control devices or systems can be performed by any automotive repair establishment or individual using Ford or ROUSH® replacement parts or EPA certified parts without voiding your federal warranty coverage for future repairs during the warranty period.

If you do not maintain your vehicle properly, ROUSH® may have the right to deny you warranty coverage.

To have repairs made under this warranty, you may have to show that you have followed Ford's and ROUSH®'s instructions on properly maintaining and using your vehicle. You will find these instructions in your Ford Owner Guide and Scheduled Maintenance Guide and this ROUSH® Owner's Guide Supplement. Be sure to save your service receipts and to keep accurate records of all maintenance work.

SECTION 11 - ROUSH®'S WARRANTY COVERAGE AND AFTERMARKET PARTS/RACING

ROUSH® vehicles are engineered for street performance and are not intended or warranted for racing on a track or otherwise. ROUSH® does not recommend modifying or racing ROUSH® vehicles, as they are designed to be driven as built and delivered from ROUSH®.

Although the installation of aftermarket parts by itself will not void the ROUSH® Limited Warranty, failures that result from these parts or modifications may result in a denial of warranty coverage by ROUSH® for such damage. The best rule of thumb is to consider whether any modification you do may cause any component to fail, and if it does, recognize that ROUSH® will likely deny warranty coverage for any subsequent damage.

If you intend to race the ROUSH® vehicle on track or otherwise, and the loss of warranty coverage is not a concern, ROUSH® recommends that you make those modifications necessary to ensure that the vehicle can be driven safely under such conditions. Again, subjecting the vehicle to racing, track preparation and participation, and competition conditions will void the ROUSH® Limited Warranty; therefore, all repairs to the vehicle will be non-reimbursable.

SECTION 12 - WARRANTY DISCLAIMER AND LIMITATION OF LIABILITY

The ROUSH® limited warranty and its remedies described in this ROUSH® owner's guide supplement are exclusive and in lieu of all other warranties, remedies, and conditions, whether oral or written, statutory, expressed or implied, as permitted by applicable law. ROUSH® specifically disclaims all express, statutory, or implied warranties, including, without limitation, the warranties of merchantability, fitness for a particular purpose, and warranties against hidden or latent defects. If ROUSH® cannot lawfully disclaim any statutory or implied warranties then to the extent permitted by law, all such warranties shall be limited in duration to the warranty period and the warranty coverage described herein. Except as provided in this warranty and to the extent permitted by law, ROUSH® is not responsible for special, indirect, consequential, incidental, or punitive damages resulting from any breach of warranty or condition, or under any other legal theory including, without limitation, loss of earnings, personal damages, personal injury (including death), personal expenses (food, room, medical, dental), or rental vehicle expenses. ROUSH®'s maximum liability to you for any and all loss or damage, whether as a result of breach of contract, warranty, tort (including negligence and strict liability), or otherwise, shall be limited to the actual price paid by you for the ROUSH® package of ROUSH® part(s) installed on the ROUSH® vehicle that gave rise to the claim.

SECTION 13 - CUSTOMER ASSISTANCE AND HOW STATE LAW APPLIES

If you are not satisfied with the handling of a warranty matter, please contact ROUSH® Performance Customer Service between the hours of 8 AM and 5 PM Eastern Standard Time, Monday through Friday, at **800.59.ROUSH (800.597.6874)**.

This ROUSH® Limited Warranty gives you specific legal rights, and you may have other rights which vary from state to state.

SECTION 14 – CALIFORNIA PROPOSITION 65 WARNING STATEMENT

WARNING: Some constituents of engine exhaust, certain vehicle components, certain fluids contained in vehicles, and certain products of component wear contain or emit chemicals known to the State of California to cause cancer and birth defects or other reproductive harm.

Appendix A – Vacuum Schematic

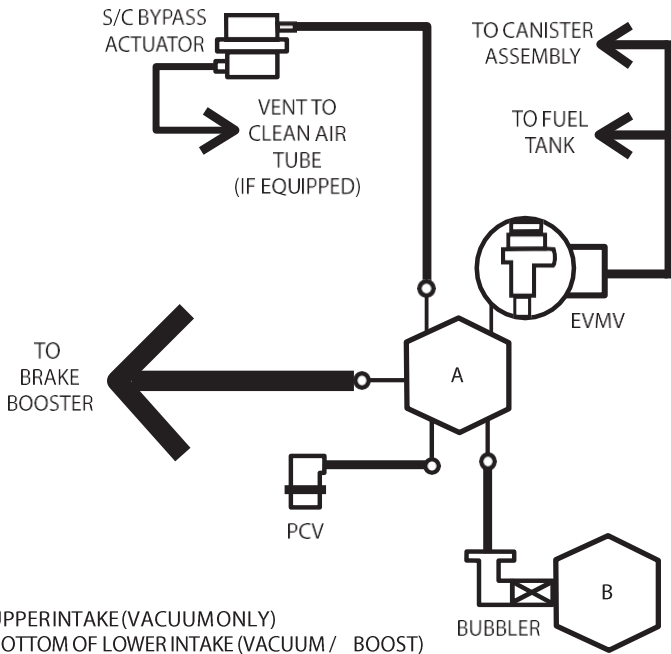

A - UPPER INTAKE (VACUUM ONLY)
B - BOTTOM OF LOWER INTAKE (VACUUM / BOOST)

Appendix B – Supercharger Accessory Belt Routing Diagram

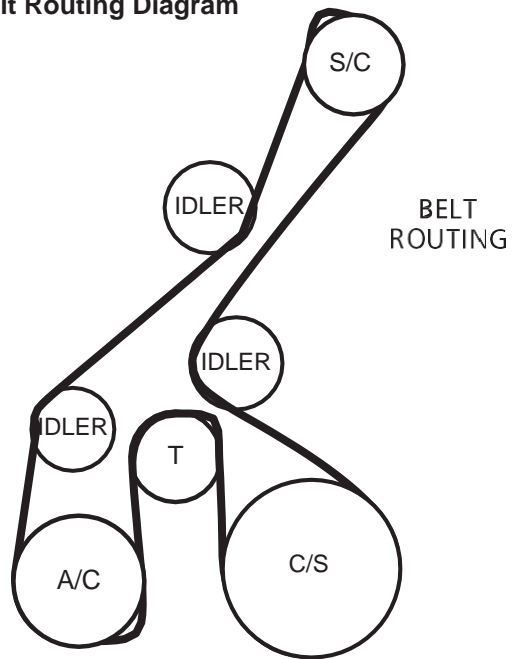

Appendix C – Summary Table

Component	Part Number*	Recommended Interval
Oil Filter	Motorcraft FL-500-S	6 months / 3,000 miles
Oil	Refer to Ford Owner's Manual: Motorcraft SAE 5W-20 Full Synthetic or Motorcraft SAE 5W-50 Full Synthetic	6 months / 3,000 miles
Spark Plugs	Contact ROUSH Customer Service for P/N	As Needed
Accessory Drive Belt	Contact ROUSH Customer Service for P/N	As Needed
Coolant	Motorcraft Specialty Orange Coolant	3 Years / 50,000 miles
*Consult your Ford Owner's Manual for all other specifications		

ROUSH® VEHICLE OWNER REGISTRATION

(Please Print)

First Name _____ Middle Name _____ Last Name _____

Street Address _____

City _____ State _____ Zip _____

Daytime Phone _____ e-mail address _____

ROUSH® VIN: _____ Serial #: _____ (found in passenger door jamb)

Purchase Date: _____ Dealership: _____ ROUSH® Model Purchased: _____

How did you learn about ROUSH®? Newspaper/Magazine Dealer Recommendation Referral
 Other _____

Have you previously purchased ROUSH® Performance products? Vehicles Parts

Where do you buy aftermarket parts? _____

Are you a member of the **ROUSH® Road Crew™**, official ROUSH® Club? Yes No

FREE first year membership in the ROUSH® Road Crew with the purchase of a new serialized ROUSH® vehicle.
\$35 value, new members only.

Yes, sign me up! Learn more at www.ROUSHroadcrew.com

Place
Stamp
Here

ROUSH Registration
39555 Schoolcraft Rd.
Plymouth Twp., MI 48170