

**MODEL: RSL-2701
RSL-2701U
RSL-380**

ROLL LAMINATOR SERVICE MANUAL



Table of Content

1.Safety Precautions	3 ~ 3
2.Troubleshooting	4 ~ 10
2.1) Rollers Not Heating	4 ~ 6
2.2) Rollers Over Heating	6 ~ 7
2.3) Rollers Not Running	8 ~ 9
2.4) No Main Power	9 ~ 10
2.5) Poor Lamination Quality	11 ~ 11
3.Replacing Parts	12 ~ 18
3.1) Right Cover	12 ~ 12
3.2) Left Cover	13 ~ 13
3.3) Rear Cover	13 ~ 14
3.4) Main PCB	14 ~ 14
3.5) Sub PCB	15 ~ 15
3.6) Heaters	15 ~ 16
3.7) Cross Cutter	16 ~ 17
3.8) Replacement of Motor.....	17 ~ 18
4.Adjustments	19 ~ 19
5. Parts List	20 ~ 23
6.Exploded Drawings	24 ~ 34
7.Wire Diagram	35 ~ 38

1. Safety Precautions

Failure to comply any of the following safety procedures could result in serious injury. Please read the instructions carefully and keep for future reference.

1. Only a licensed electrician should install wiring and outlet for the laminator.
2. Ensure the unit is plugged into a properly grounded outlet with the correct voltage.
3. Keep hands and clothing (ie. Neckties) away from rollers. The rollers are pinch points that can trap body parts or clothing and cause serious injury .
4. Keep flammable and wet objects away from the machine .
5. Place machine on a level surface.
6. Avoid excessive sunlight, humidity and extreme temperatures.
7. Ensure the unit is turned off, cooled ,and unplugged from the outlet prior to moving and/or repairing.
8. Keep out of reach of children.
9. Only Royal Sovereign authorized maintenance and service technicians should make repairs.
10. Do not attempt to laminate items that exceed total recommended material thickness for the unit.
11. When cleaning the machine, don't use flammable sprays or materials.
12. Do not touch the rollers when they are hot or place foreign objects inside the machine.
13. Do not cover the surface of the machine until the machine has completely cooled.

2. Troubleshooting

2.1 Rollers Not Heating

CAUSES

1. The wire connector from the heater is disconnected with MAIN PCB.(except RSL-380)
2. The Wire-Temp Fuse is disconnected.
3. The Main Fuse is defective.(except RSL-380)
4. The Bi-metal is defective.
5. The heater in the roller is defective.
6. Main PCB is defective.

MEASURES

- Before troubleshooting, be sure to disassemble the Right cover , the Left cover and the Frame Rear.
- Refer to how to replace each component for the disassembly of them.

1. The wire connector from the heater is

disconnected with MAIN PCB.(except RSL-380)

- 1) Test if the connector wire is disconnected with Multi-tester.
- 2) If disconnected, replace it with new one.

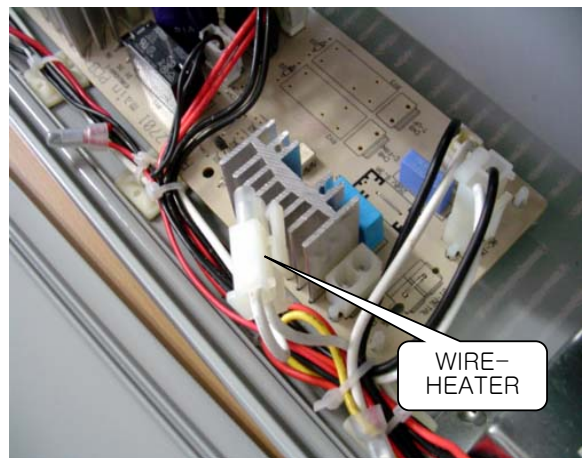

2 The Wire-Temp Fuse is disconnected

- 1) Test if the Wire-Temp Fuse is disconnected with Multi-tester.
- 2) If disconnected, replace it with new one.

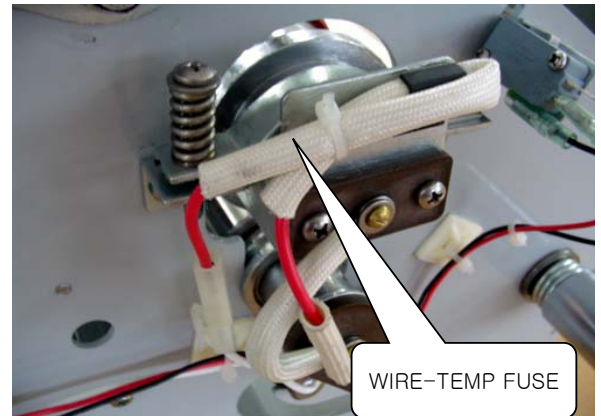

3. MAIN FUSE is disconnected.(except RSL-380)

- 1) Test if the Main Fuse is disconnected with Multi-tester.
- 2) If disconnected, replace it with new one.

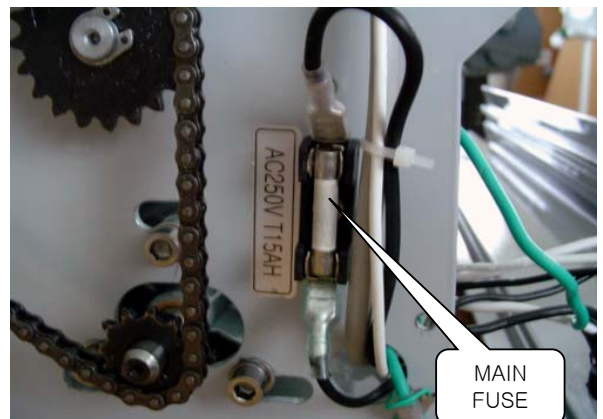

4. The Bi-metal is defective.

- 1) Disconnect the heater wire from the Bi-metal.
- 2) Unfasten 2 screws holding the Bi-metal.
- 3) Replace it with new one.

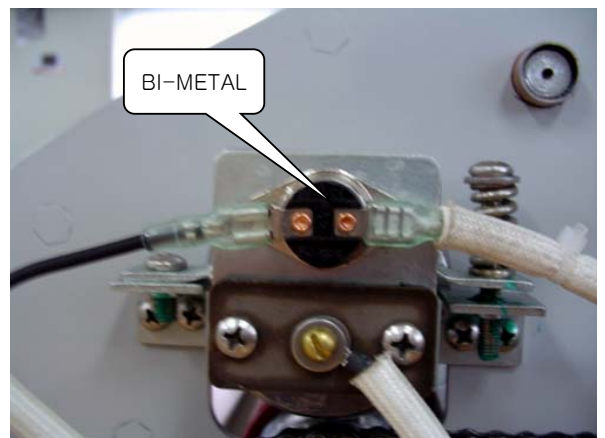

5. The heater in the roller is defective.

- 1) Test if the heater is disconnected with Multi-tester.
- 2) If disconnected, replace it with new one.



6. Main PCB is defective.

Replace Main PCB with new one according to How to replace Main PCB only when all of the above mentioned heater wire, wire thermal fuse, heater and Bi-metal are normal.

2.2 Rollers Not Heating

CAUSES

1. The Temperature Sensor is not work.
2. The wire thermal fuse is defective.
3. The heater in the roller is defective.
4. Main PCB is defective.

MEASURES

- Before trouble shooting, be sure to disassemble the Right cover , the Left cover and the Frame Rear.
- Refer to how to replace each component for the disassembly of them.

1. The Temperature Sensor is not work.

- 1) Disassemble the Right cover. (Refer to how to replace Cover-R.)
- 2) Disassemble the Bracket-Sensor with Sensor ass'y.
Test if the Sensor ass'y is disconnected with Multi-tester.
Again, Attach The Bracket-Sensor as the proper position.

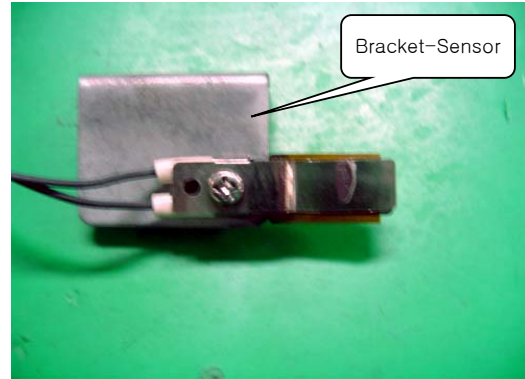
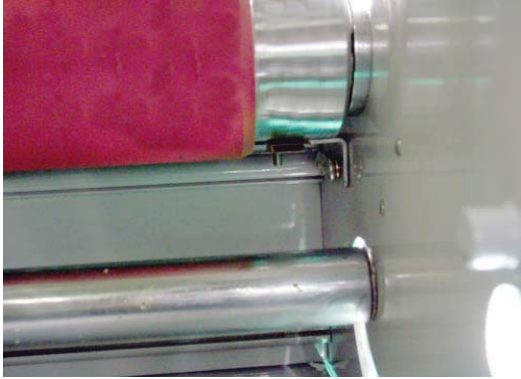

<Sensor Ass'y position>

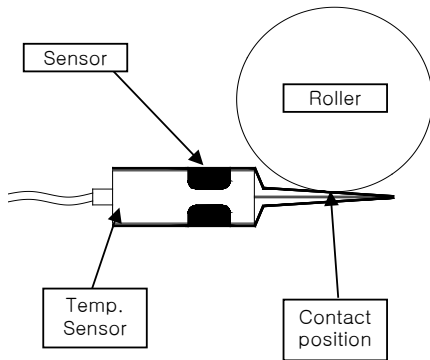

<The Proper position>

<Sensor Ass'y>

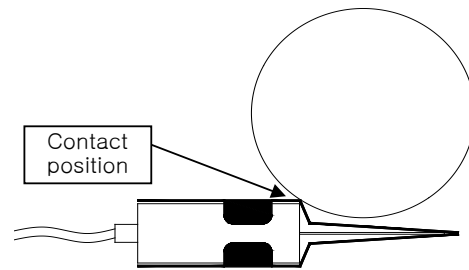

<The wrong position>

2. The wire thermal fuse is defective.

- 1) Test if the wire thermal fuse is disconnected with Multi-tester.
- 2) If disconnected, replace it with new one.

3. The heater in the roller is defective.

- 1) Test if the heater is disconnected with Multi-tester.
- 2) If disconnected, replace it with new one.

4. Main PCB is defective.

- 1) Replace Main PCB with new one according to How to replace Main PCB only when all of the above mentioned heater wire, wire thermal fuse, heater and Bi-metal are normal.

1. The Temperature Sensor is not work.

- 1) Disassemble the Right and the Left cover. (Refer to how to replace Cover.)
- 2) Disassemble the Bracket-Sensor with Sensor ass'y.
Test if the Sensor ass'y is disconnected with Multi-tester.

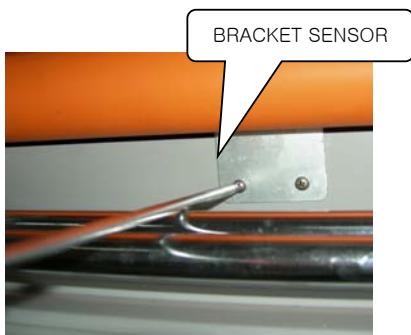

<Sensor Ass'y position>

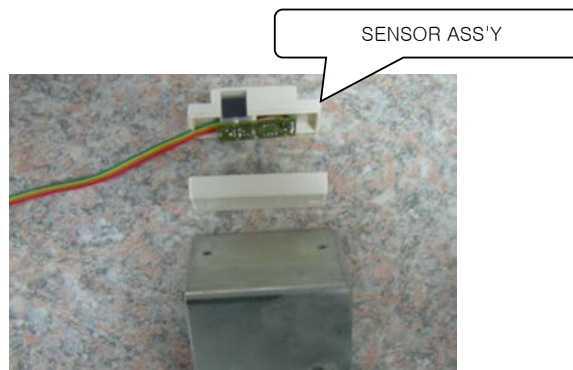

<Sensor Ass'y>

2. The wire thermal fuse is defective.

- 1) Test if the wire thermal fuse is disconnected with Multi-tester.
- 2) If disconnected, replace it with new one.

3. The heater in the roller is defective.

- 1) Test if the heater is disconnected with Multi-tester.
- 2) If disconnected, replace it with new one.

4. Main PCB is defective.

- 1) Replace Main PCB with new one according to How to replace Main PCB only when all of the above mentioned heater wire, wire thermal fuse, heater and Bi-metal are normal.

2.3 Rollers Not Running

CAUSES

1. Safety cover is not in proper position.
2. Wire-Motor's connector is disconnected.
3. Film is jammed on the rollers.
4. Main PCB is defective.
5. Main motor is defective.

MEASURES

- Before troubleshooting, be sure to disassemble the Right cover ,the Left cover and the Rear cover.
- Refer to how to replace each component for the disassembly of them.

1. Safety cover is not in proper position.

- 1) Make the edge of Safety Cover to press the lever of Micro Switch completely.

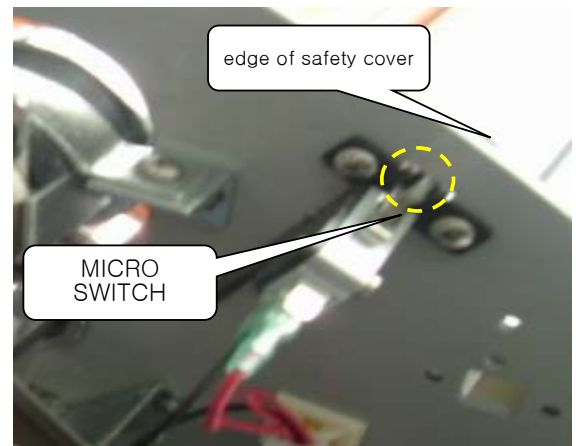

2. Motor wire connectors are disconnected.

- Check if the Motor wire connectors are connected correctly.

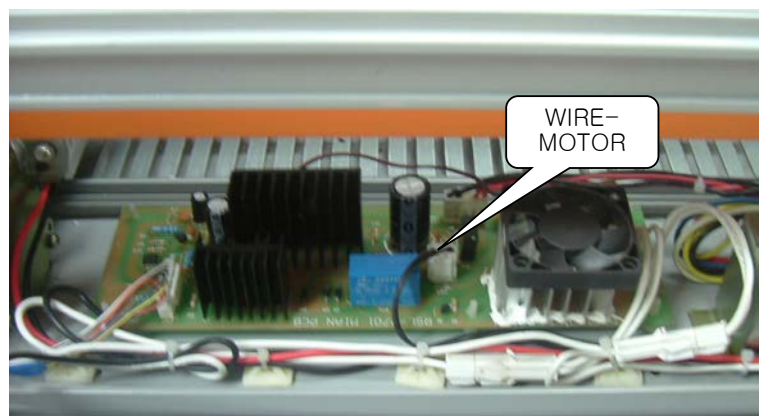

3. Film is jammed on the rollers.

- 1) First press reverse button.
- 2) Pull jammed film slowly to the back of the machine.
- 3) If you feel film is jammed again, stop pressing reverse button.
- 4) press run button, and then pull jammed film to the back of the machine.

4. Main PCB is defective

Replace Main PCB with new one according to How to replace Main PCB only when all of the above mentioned Emergency switch, Frame paper guide, Safety cover switch, motor wire connectors, main motor and film are normal.

5. Replace Motor with new one according to How to replace the Motor.

2.4 No Main Power

CAUSES

1. Main power wire is not connected with Main Switch
2. Main fuse is disconnected.(except RSL-380)
3. Wire-AC IN is not connected with Main PCB.(except RSL-380)
4. Transformer is defective.

MEASURES

- Before troubleshooting, be sure to disassemble the Right cover , the Left cover and the FRAME Rear.
- Refer to how to replace each component for the disassembly of them.

1. Main power wire is not connected with Main Switch.

- 1) Check if the Main power wires are connected correctly.

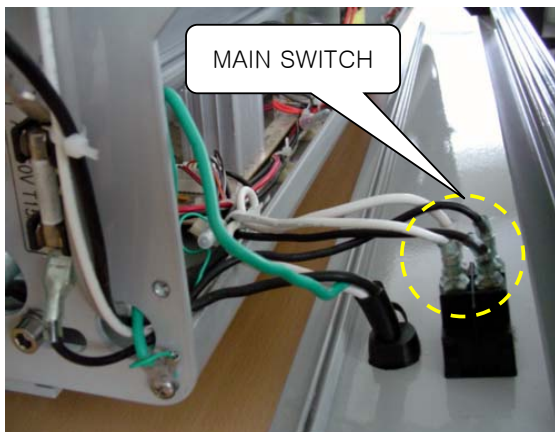

<RSL-2701/2701U>

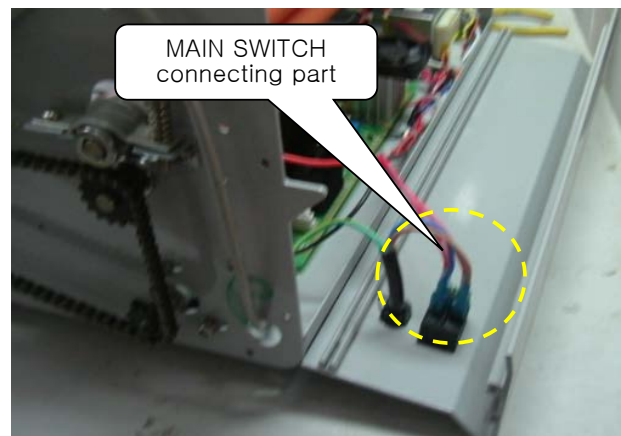

<RSL-380>

2. Main fuse is disconnected.(except RSL-380)

- 1) Test if the main fuse is disconnected with Multi-tester.
- 2) If disconnected, replace it with new one.

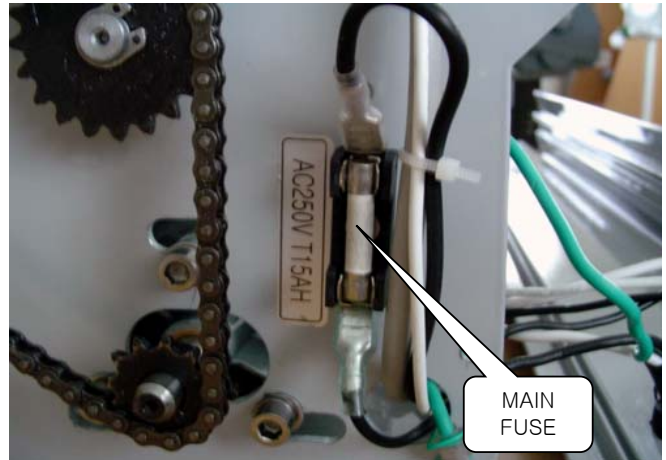

3. Wire-AC IN is not connected with Main PCB.(except RSL-380)

- 1) Check if the Wire-AC IN are connected correctly.



4. Transformer is defective.

- 1) Unfasten two screws.
- 2) Separate 2 connectors.
- 3) Detach transformer.
- 4) Replace it with new one.

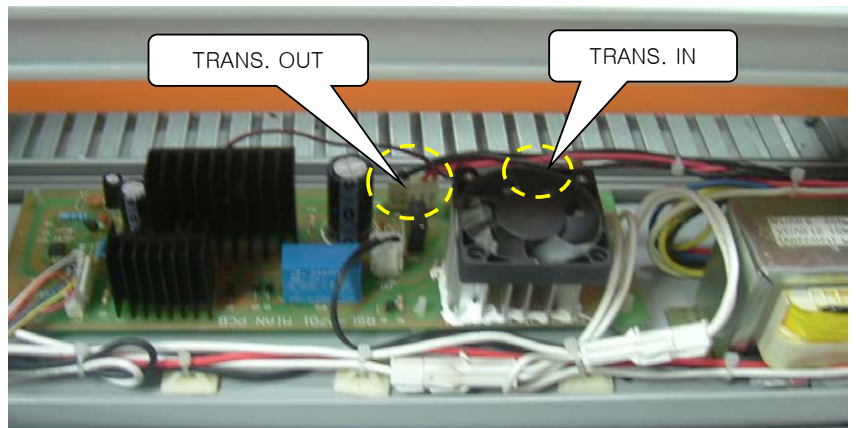

2.5 Poor Lamination Quality

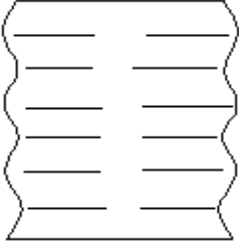
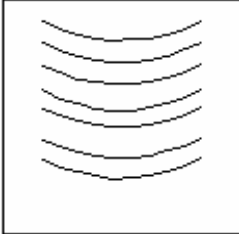
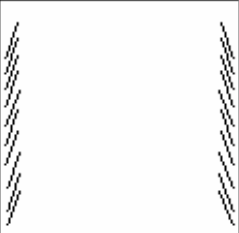
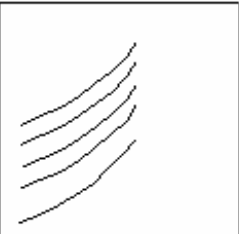
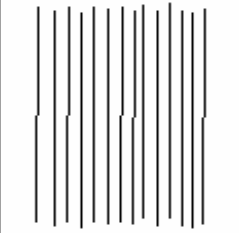
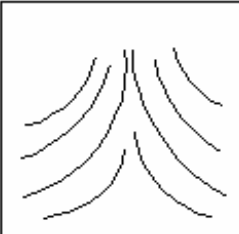
<p>Problem: Straight wave lines across the output.</p> <p>Cause: Excessive front roller pressure.</p> <p>Measure: Loosen the front roller pressure.</p>	
<p>Problem: Concave waves in the lamination.</p> <p>Cause: Excessive rear (pulling) roller pressure.</p> <p>Measure: Loosen the rear back roller pressure.</p>	
<p>Problem: Angled waves on both sides of the output.</p> <p>Cause: Insufficient rear roller pressure.</p> <p>Measure: Tighten the rear roller pressure.</p>	
<p>Problem: Angled waves on one side of the output.</p> <p>Cause: Insufficient rear left (or right) side roller pressure.</p> <p>Measure: Tighten the rear left (or right) side roller pressure.</p>	
<p>Problem: Straight waves in the output.</p> <p>Cause: Excessive heat at the nip rollers.</p> <p>Measure: Lower the roller temperature.</p>	
<p>Problem: Wake waves.</p> <p>Cause: Insufficient heat at the nip rollers.</p> <p>Measure: Raise the roller temperature.</p>	

3. Replacing Parts



Caution :

Turn off the switch of the machine and then pull out the power cord plug from the electrical outlet.

3.1. Right Cover

- 1) Unfasten 4 screws holding the Right cover and disassemble the Right cover.



<RSL-2701/2701U>

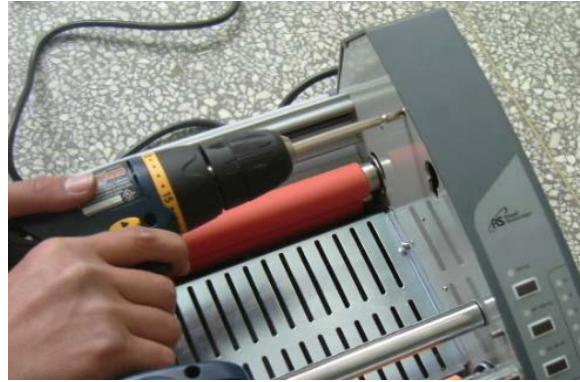

<RSL-380>

- 2) Pull out the male connector from the Sub-PCB .



- 3) Unfasten 4 screws holding the Sub-PCB and detach the Sub-PCB.



- 4) How to assemble is the reverse order of how to disassemble , 3)→2)→1).

3.2. Left Cover

1) Unfasten 2 nuts holding the Knob Tension

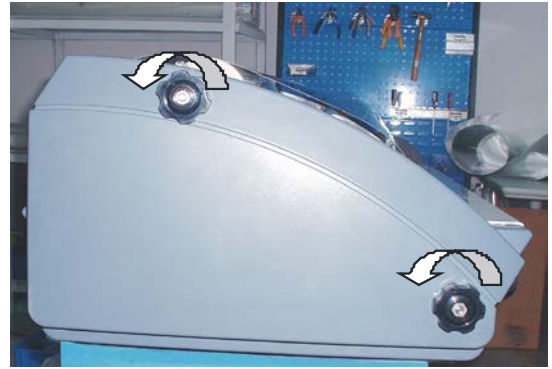

2) disassemble the Knob-Tension.



3) Unfasten 4 screws holding the Left cover and disassemble the Left cover .

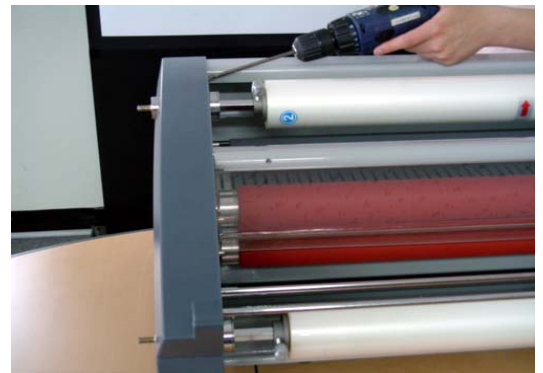

4) How to assemble is the reverse order of how to disassemble . 3)→2)→1).

3.3. Rear Cover

1) Disassemble both the Right cover and the Left cover.

2) Unfasten 4 screws holding the Rear cover (right and left) .

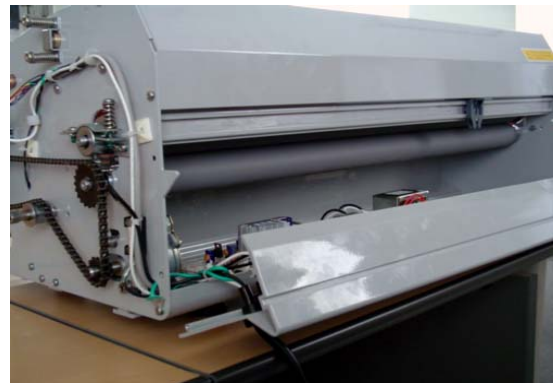

- 3) Disassemble Wire connect to MAIN S/W,
POWER CORD.



- 4) Disassemble MAIN S/W and POWER CORD.
- 5) How to assemble is the reverse order of how to disassemble , 4)→3)→2)→1).

3.4. Main PCB

- 1) Pull out all the connectors from the main PCB.



- 2) Detach the main PCB from
4 white plastic supporters.

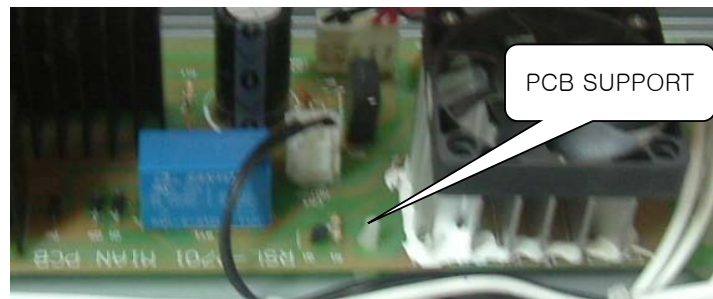

- 3) How to assemble is the reverse
order of how to disassemble ,2)→1).

3.5. Sub PCB

- 1) Refer to No 1.(Replacement of cover-R)



3.6. Heaters

- 1) Disassemble both the Right cover and the Left cover (Refer to No.1, No.2) .

- 2) Unfasten 2 screws holding the heater and disassemble the wire.

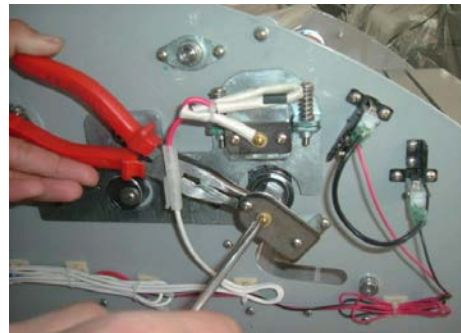
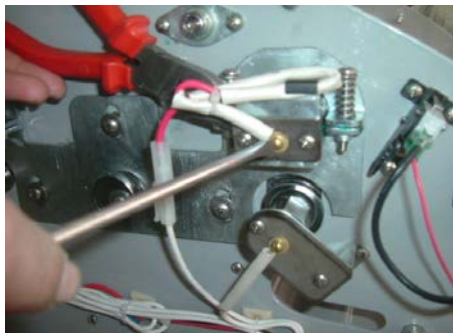

< Detachment 2 screws holding the heater>

- 3) Unfasten 2 screws and disassemble the bracket holding the lower heater.

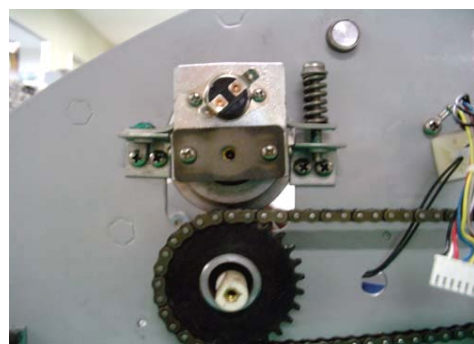
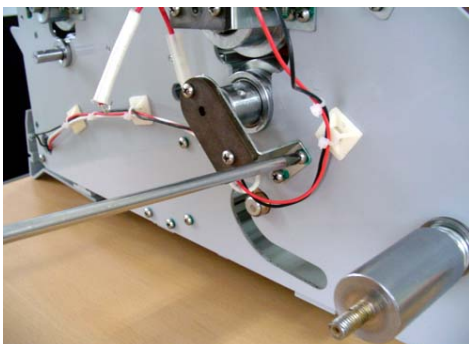

< Detachment of Bracket-Heater>

4) Disassemble the Bush-Roller, Up holding the upper heater.

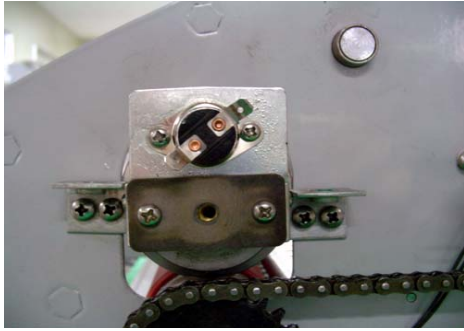

< Take off Bush-Roller, Up from Laminating Roller >

5) Disassemble the lower and upper heater from the roller cautiously



6) How to assemble is the reverse order of how to disassemble , 5)→4)→3)→2)→1).

When inserting the heater into the roller, rotate the heater slightly and the heater enter the roller smoothly.

3.7. Cross Cutter

1) Disassemble both the Right cover and the Left cover (Refer to No.1, No.2) .

2)a. Unfasten 6 screws holding the Frame-Upper.(RSL-2701/2701U)

b. Unfasten 1 screw on the Frame-cutter.(RSL-380)

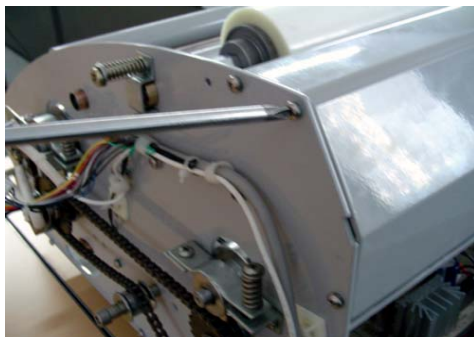

<RSL-2701/2701U>



<RSL-380>

3)a. Disassemble Frame upper with Cross Cutter.(RSL-2701/2701U)

b. Disassemble Cross Cutter from the Frame-Cutter.(RSL-380)



<RSL-380>

4) Disassemble the Cross Cutter from the Frame-Upper.(RSL-2701/2701U)



<RSL-2701/2701U>

5)a. How to assemble is the reverse order of how to disassemble , 4)→3)→2)→1).(RSL-2701/2701U)

b. How to assemble is the reverse order of how to disassemble , 3)→2)→1).(RSL-380)

3.8. Replacement of MOTOR

1) Disassemble the Right cover , the Left cover and the frame rear

2) unfasten the screw (PULLEY-CHAIN)

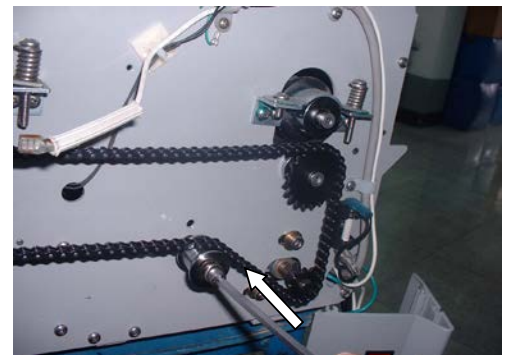

3) unfasten the set screw (sprocket motor)

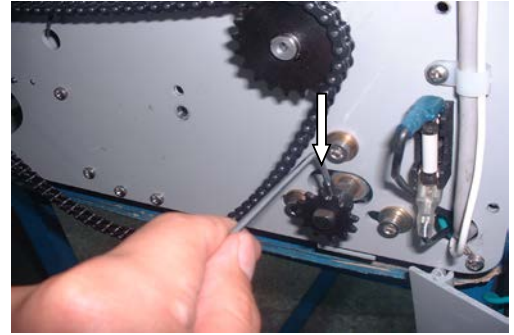

4) take out the sprocket motor from the motor

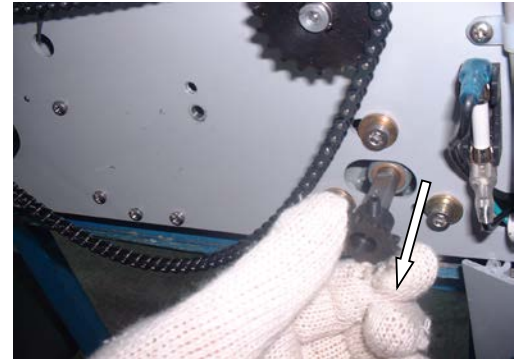

5) unfasten the three screws from the motor

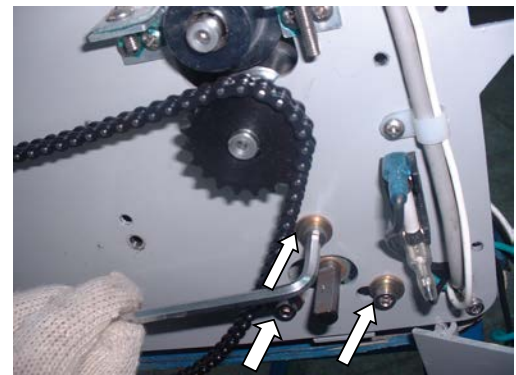

6) detach the connector and change the motor

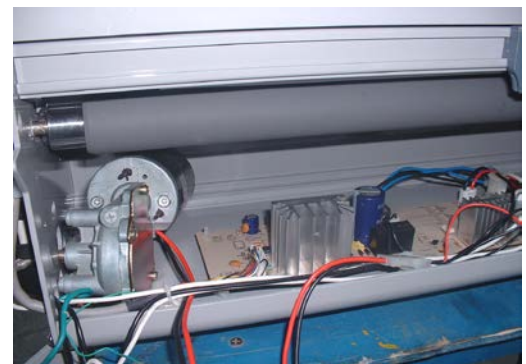

7) How to assemble is the reverse order of how to disassemble , 6)→5)→4)→3)→2)→1).

4. Adjustments

Adjusting Front and Rear Roller

Pressure

- *Use Screwdriver* to adjust the roller pressure:
C.W – Increase pressure.
C.C.W – Decrease pressure.

1. *Using Push-Pull Scale*, measure 5 spots as shown on Figure B & C: Front roller should be 2~3 and back rollers should be 5~7.

2. *Checking for over all tension* – when the machine is running, check that the top and the bottom films are fed in without any wrinkles.

3. *Pressure mark checking (Heat Line)* – stop the machine for 30 seconds to create a heat line. Then check to see if you have two even parallel lines from one end to other. Note: A narrow parallel lines indicate that it has less pressure at that point.

4. *Laminating Test* – Laminate samples with different thickness of substrates.

5. *Check above steps 2 through 4* with 3mil & 5mil films.

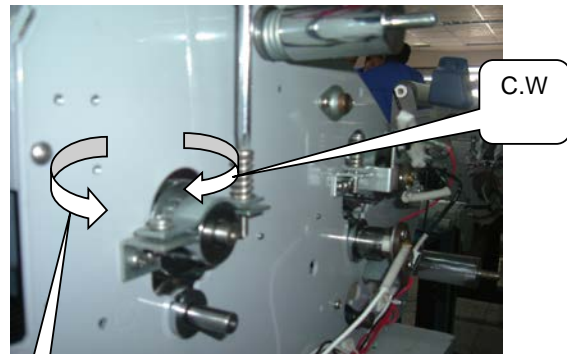

Figure A

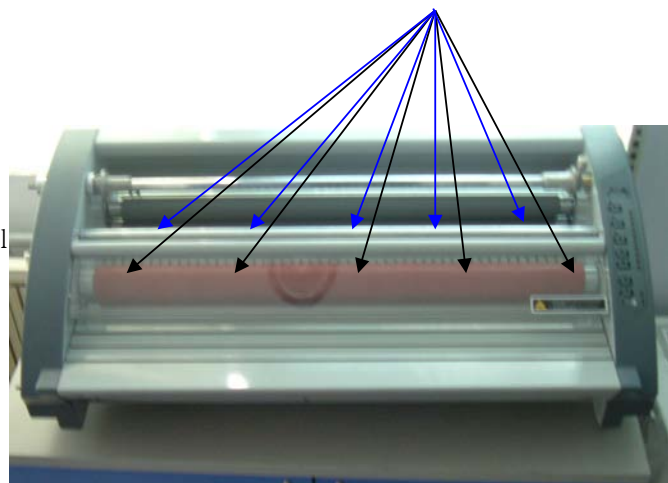

Figure B



Figure C

SVC Parts List

RSL-2701/2701U

No.	Part No.	Part Name	Spec.	CHANGING REMARK	
				P NO.	DATE
1	013LR2026A	BASE-FRONT	AL6063		
				013LR2033A	20050317
				013LR3075A	20060710
2	026004005A	FOOT	NATURAL RUBBER		
3	013LR2027A	BASE-REAR	AL6063		
				013LR2032A	20050317
				013LR3076A	20060710
4	350LR3008A	PCB-MAIN ASS'Y	FR-4		
			Chang the AC IN and Heater's connector		20050423
5	34000S009B	POWER TRANSFORMER-OTHERS	220-240V 50/60Hz		
5-1	34000S009C	POWER TRANSFORMER-CUL JAP	100-120V 50/60Hz		
6	23200X001A	SUPPORT PCB	NYLON 66		
7	013LR2030A	FRAME-UPPER	AL6063		
				013LR3002K	20101013
8	021CR3001A	KNOB CUTTER C	ABS PA-765 431C		
9	140LR3001A	HOLDER-CUTTER,C	ABS PA-765 431C		
10	213LR4001A	CUTTER-CROSS	STS420 J2 1T		
11	013LR3019A	FRAME-CENTER	AL6063		20050317
12	013LR3021A	PLATE-MIDDLE	SPCC 1.6T		
13	013LR2024B	FRAME-L	SPCC 3.0T		
				013LR2034A	20050427
14	141LR4017A	BRACKET-PRESSURE	SPCC 2.0T		
15	141LR4035A	PLATE-DU BUSH	SPCC 2.0T		
16	141LR4054A	BRACKET-MICRO S/W	SPCC 1.2T		
17	36400X014A	MICRO S/W	DECO VP-531A-2H		
18	013LR2025B	FRAME-R	SPCC 3.0T		
				013LR2035A	20050427
19	134LR4003A	BUSH-PULLEY	S45C Φ10		
20	134LR4001A	PULLEY-CHAIN	S45C		
21	141LR4021A	BRACKET-SHAFT FILM	SPCC 1.6T		20070305
22	141LR4018A	BRACKET-SENSOR	SPCC 2.0T		
				141LR4059A	20061221
					20070420
23	31300S004A	SENSOR-CAS AOM A/B 300V FT1	SENSOR		
		ASM-SENSOR		ASMLR1640A	20061221
					20070420
24	033LR4016A	MICA-WASHER	PL		20060205
25	133LR2021B	ROLLER-LAMI,UP	STPG ORG		
26	122LR4014A	BUSH-ROLLER LAMI,UP	S45C Cu+Ni+Cr		
				122LR4044A	20060607
27	12200X028A	DU BUSH	Φ25*20 FLANGE		
28	133LR2021A	ROLLER-LAMI,LO	STPG SILICONE		
29	122LR4015A	BUSH-ROLLER LAMI,LO	S45C Cu+Ni+Cr		
				122LR4045A	20060607
				122LR4050A	20060828
30	12200X027A	DU BUSH	Φ25*10 FLANGE		
31	133LR2022B	ROLLER-PULL,UP	S45C GRY		
32	122LR4046A	BUSH-ROLLER PULL,UP	FTG70Cu3-35 BLK		
33	12200X030A	DU BUSH	Φ10*20 FLANGE		
34	133LR2022A	ROLLER-PULL,LO	S45C GRY		
35	122LR4047A	BUSH-ROLLER PULL,LO	FTG70Cu3-35 BLK		
36	12200X029A	DU BUSH	Φ10*10 FLANGE		
37	120LR3012A	SHAFT-FILM	S45C		
39	023LR4004A	KNOB-TENSION	SKN2 403 BRAMA		

40	120LR4006A	SHAFT-TENSION	S45C		
41	141LR4025A	PLATE-HOLDER SHAFT	SPCC 2.0T		20091201
42	140LR4008A	HOLDER-SHAFT FILM	S45C		
				140LR4039A	20091201
43	12200X033A	BEARING-RADIAL TRUST	NTB1730 17*30		
44	147LR4008A	PAD-TENSION	LEATHER 1.5T		
45	124LR4003A	CORE-24	AL6063		
46	015LR2001B	IDLE BAR	S45C Φ 20		
47	12200X032A	DU BUSH	Φ 12*10 FLANGE		
48	210004002A	MOTOR-MAIN	DC24V		
				21000S038A	20100419
49	131LR4021A	SPROCKET-MOTOR	S45C 12Z		
				131LR4034A	20070317
50	223LR2007A	HEATER ASS'Y-EU UNIB AU KR DE	FCHW1 17.5 Ω (230V)		
50-1	223LR2007B	HEATER ASS'Y -CUL	FCHW1 19.5 Ω (120V)		
50-2	223LR2007C	HEATER ASS'Y -JAP	FCHW1 15 Ω (100V)		
51	141LR4019A	BRACKET-HEATER,UP	SPCC 1.6T		
52	141LR4027A	STOPPER-HEATER,UP	PPS		
				147LR4013A	20070702
53	141LR4020A	BRACKET-HEATER,LO	SPCC 1.6T		
54	141LR4028A	STOPPER-HEATER,LO	PPS		20070702
55	141LR4032A	BRACKET-PRESSURE,LAMI	SPCC 1.6T		
56	141LR4033A	BRACKET-PRESSURE,PULL	SPCC 1.6T		
57	363LR4001D	BI-METAL	110 $^{\circ}$ C 15A		
				363LR4001E	20031201
				363LR4001F	20070420
58	131LR4017A	SPROCKET-LAMI	FRG70Cu3-35 28Z		
59	131LR4018A	SPROCKET-PULL	FRG70Cu3-35 20Z		
60	136LR4006A	CHAIN	RS #25 P=6.35		
				136LR4001C	20060801
61	014LR3001A	TABLE-FRONT	AL6063		
62	145LR3002A	GUIDE-DOCUMENT	ABS PA-765 431C		
63	023LR4002A	KNOB-BOLT GUIDE M4	S45C		
64	111LR4006A	BOLT-GUIDE	S45C		
65	013LR3016A	FRAME-SAFETY COVER	AL6063		
				013LR4004A	20060617
66	021LR3007A	COVER-SAFETY	PC 3T		
				021LR3024B	20060617
67	120LR4009A	SHAFT-COVER SAFETY	S45C		
				111LR4018A	20060617
68	381LR4052A	WIRE-MOTOR	UL1007 AWG#20, BLK, RED		
69	381LR4050B	WIRE-HEATER, EU,AU,UK;	UL1015 AWG#16, WHT		
69-1	381LR4062B	WIRE-HEATER, USA;	UL1015 AWG#18, WHT		
70	381LR4061B	WIRE-AC IN	UL1015 AWG#18, WHT/BLK		
71	381LR4049B	WIRE-BIMETAL	UL1015 AWG#14, BLK		
72	381LR4063A	WIRE-TEMP FUSE	UL1015 AWG#14, RED 15A 133C		
73	381LR4064A	WIRE-FUSE	UL1015 AWG#18, BLK		
74	381LR4053A	WIRE-MAIN	UL2464 AWG#24, BLK		
75	32500X0005	FUSE-OTHERS	65TS AC250V 20A		
75-1	32500X0007	FUSE-EU UNIB AU KR UK DE	65TS AC250V 10A		
76	36600X001A	FUSE-HOLDER	FB66 LITTLE FUSE TRIAD INC.		
77	013LR3009A	FRAME-REAR	AL6063		
78	36400X002A	SWITCH-MAIN	8216 B/R I/O SIGNAL-LUX SPA		
				36400X002B	20080620
79	380LR4001A	POWER CORD	EU UNIB DE AC250V,15A,1.8M		
79-1	380CR4004A	POWER CORD	CUL AC125V,15A,1.8M		
79-2	380CR4003A	POWER CORD	JAP AC125V,15A,1.8M		
79-3	380LR4003B	POWER CORD	AU AC250V,15A,1.8M		
79-4	380CR4007A	POWER CORD	UK AC250V,15A,1.8M		
79-5	380LR4001B	POWER CORD	KR AC250V,15A,1.8M		
80	23300X001A	BUSHING-CORD	7NR32 DONG-A		

81	120LR4008A	SHAFT-TABLE	S45C ϕ 5		
82	021LR0002A	COVER-R	ABS PA-765 431C		
83	350LR3009A	PCB-CONTROL ASS'Y	FR-4		
				350LR3037A	20061221
					20070420
84	021LR2006A	KNOB-CONTROL	ABS PA-765 431C		
85	032LR3003A	INLAY-CONTROL	EU,AU,UK PC T=0.25		
85-1	032LR3003B	INLAY-CONTROL	JAP,CUL PC T=0.25		
85-2	032LR3003C	INLAY-CONTROL	EU-N,JAP-N,AU-N PC T=0.25		
85-3	032LR3003D	INLAY-CONTROL	CUL-N PC T=0.25		
85-4	032LR3003E	INLAY-CONTROL	UNIB PC LEXAN T=0.25		
85-5	032LR3007A	INLAY-CONTROL	CUL2 PC LEXAN T=0.25		
86	021LR0001A	COVER-L	ABS PA-765 431C		
90	138LR4001A	SPRING-CUTTER CROSS	SWRH ϕ 0.3		
91	138LR4012A	SPRING-TENSION	SWP ϕ 3.2		
92	138LR4015A	SPRING-PRESSURE	SWP ϕ 2.0		
93	110LP4009B	SCREW-CLAMP;M5	SWRH		
94	111LR4004A	BOLT-CORE	S45C SNC3		
95	138LR40123	SPRING-SHAFT FILM	SUS304-WPB ϕ 0.9		20070305
97	381LR4051A	WIRE-HEATER LINK;	UL1015 AWG#18 BLK		
98	141LR4043A	FRONT TABLE SAFETY LEVER	SPCC		20060617

SVC Parts List

RSL-380

No.	Part No.	Part Name	Spec.	CHANGING REMARK	
				P NO.	DATE
1	013LR3069A	BASE-FRONT	SPCC 1.5T		
2	026004005A	FOOT	NATURAL RUBBER		
3	013LR3070A	BASE-REAR	SPCC 1.5T		
4	350LR3008C	PCB-MAIN ASS'Y EU,AU,KR,CH,UK	FR-4		
4-1	350LR3008D	PCB-MAIN ASS'Y CUL,JAP	FR-4		
5	34000S009B	POWER TRANSFORMER(EU,AU,KR,CH,UK)	220~240V/50~60Hz		
5-1	34000S009C	POWER TRANSFORMER(JAP,CUL)	100-120V/50~60Hz		
6	23200X001A	SUPPORT-PCB	NYLON 66		
7	021CR3001A	KNOB-CUTTER,C	ABS PA-765 UL94 V-0 PANTON 431C		
8	140LR3001A	HOLDER-CUTTER,C	ABS PA-765 UL94 V-0 PANTON 431C		
9	213LR4001A	CUTTER-CROSS	STS420 J2 1T		
10	013LR3035A	PLATE-MIDDLE	SPCC 1.0T		
11	013LR3067A	FRAME-L	SPCC 3.0T		
12	141LR4017A	BRACKET-PRESSURE	SPCC 2.0T		
13	141LR4035A	PLATE-DU BUSH	SPCC 2.0T		
14	141LR4054A	BRACKET LIMIT SWITCH	SPCC2.0		
15	36400X014B	MICRO S/W	DECO VP-531A-2H		
16	021LR4001A	LIMIT SWITCH COVER	PP		
17	013LR3068A	FRAME-R	SPCC 3.0T		
18	133LR3001A	ROLLER-LAMI	STPG ORANGE		
19	122LR4044A	BUSH-ROLLER LAMI,UP	FTG70Cu3-35		
20	12200X028A	DU BUSH	Φ25*20 FLANGE		
21	122LR4050A	BUSH-ROLLER LAMI,LO ASS'Y	FTG70Cu3-35		
1)	12200X027A	DU BUSH	Φ25*10 FLANGE		
23	133LR3004A	ROLLER-PULL, LOW	S45C ORANGE		
23-1	133LR3005A	ROLLER-PULL, UP	S45C ORANGE		
24	122LR4043A	BUSH-ROLLER PULL,UP	S45C Cu+Ni+Cr		
25	12200X030A	DU BUSH	Φ10*20 FLANGE		
26	122LR4047A	BUSH-ROLLER PULL,LO	FTG70Cu3-35		
27	12200X029A	DU BUSH	Φ10*10 FLANGE		
28	120LR3020A	SHAFT-FILM	S45C Cu+Ni+Cr		
29	12200X002A	DU BUSH	Φ10*10 FLANGE		
30	023LR4004A	KNOB-TENSION	SIXN2 (PF+BRASS) 403 BRAMA		
31	120LR4006A	SHAFT-TENSION	S45C Cu+Ni+Cr		
32	141LR4025A	PLATE-HOLDER SHAFT	SPCC 2.0T		20081013
33	140LR4008A	HOLDER-SHAFT FILM	S45C Cu+Ni+Cr		
				140LR4039A	20081013
34	12200X033A	BEARING-RADIAL TRUST	NTB 17*30		
35	147LR4008A	PAD-TENSION	LEATHER 1.5T		
36	124LR4003A	CORE-24	AL6063		
37	015LR2002A	IDLE BAR	S45C Cu+Ni+Cr		
				015LR2010A	20080618
38	12200X032A	DU BUSH	Φ12*10 FLANGE		
39	210004002A	MOTOR-MAIN	DC24V		
				21000S038A	20100419
40	131LR4021A	SPROCKET-MOTOR	FTG70Cu3-35 15Z		
				131LR4034A	20080728
41	223LR3001D	HEATER ASS'Y	FCHW1 20.2Ω EU,AU,CH,KR		

SVC Parts List

RSL-380

No.	Part No.	Part Name	Spec.	CHANGING REMARK	
				P NO.	DATE
41-1	223LR3001E	HEATER ASS'Y	FCHW1 24Ω CUL,UK		
41-2	223LR3001F	HEATER ASS'Y	FCHW1 16.7Ω JAP		
42	141LR4019A	BRACKET-HEATER,UP	SPCC 1.6T		
43	141LR4027A	STOPPER-HEATER,UP	PPS		
				147LR4013A	20070702
44	141LR4020A	BRACKET-HEATER,LO	SPCC 1.6T		
22					
45	141LR4028A	STOPPER-HEATER,LO	PPS		20070702
46	141LR4032A	BRACKET-PRESSURE,LAMI	SPCC 1.6T		
47	141LR4033A	BRACKET-PRESSURE,PULL	SPCC 1.6T		
48	363LR4001E	BI-METAL	15A 110°C KSD020-1		
49	131LR4017A	SPROCKET-LAMI	FTG70Cu3-35 28Z		
				131LR4037A	20060922
50	131LR4033A	SPROCKET-PULL	S45C Z15		
51	136LR4012A	CHAIN	RS#25 P=6.35		
				136LR4001F	20060509
52	014LR3001B	TABLE-FRONT	AL6063		
53	145LR3002A	GUIDE-DOCUMENT	ABS PA-765 UL94 V-0 PANTON 431C		
54	023LR4002A	KNOB-BOLT GUIDE	M4		
55	111LR4006A	BOLT-GUIDE	S45C Cu+Ni+Cr		
56	013LR4004A	FRAME-COVER SAFETY	SPCC 2.5T		
57	021LR3024A	COVER-SAFETY	PC 3T		
58	141LR4043A	FRONT TABLE SAFETY LEVER	SPCC 1.5T		
59	111LR4018A	SCREW-H	SWRH MFZn-Y		
60	381LR4049A	WIRE-BIMETAL	UL1015 AWG#18, BLK		
61	31300S004A	SENSOR	CSA AOM A/B 300V FT1		
62	381LR4063A	WIRE-TEMP FUSE	UL 1015AWG#14 ,133°C 15A		
63	381LR4053A	WIRE-MAIN	UL2464 AWG#24, BLK		
64	013LR3036A	FRAME-REAR	AL6063		
65	36400X002B	SWITCH-MAIN	8216 B/R 1/0 SIGNAL-LUX SPA		
66	380CR4004A	POWER CORD	CUL AC125V 15A 1.8M		
66-1	380LR4001A	POWER CORD	EU AC250V 15A 1.8M		
66-2	380CR4003A	POWER CORD	JAP AC125V 15A 1.8M		
66-3	380LR4003B	POWER CORD	AU AC250V 10A 1.8M		
			AU AC250V 15A 1.8M	380LR4003A	20070928
66-4	380CR4007A	POWER CORD	UK AC250V 13A 1.8M		
67	23300X001A	BUSHING-CORD	EU 7NR32 DONG-A		
68	013LR3002H	FRAME-CUTTER	AL6063		
69	021LR0002A	COVER-R	ABS PA-765 UL94 V-0 PANTON 431C		
70	350LR3009A	PCB-CONTROL ASS'Y	FR-4		
71	021LR2006A	KNOB-CONTROL	ABS PA-765 UL94 V-0 PANTON 431C		
72	032LR3003F	INLAY-CONTROL	PC LEXAN T=0.25		
72-1	032LR3003G	INLAY-CONTROL(CUL)	PC LEXAN T=0.25		
73	021LR0001A	COVER-L	ABS PA-765 UL94 V-0 PANTON 431C		
74	138LR4001A	SPRING-CUTTER CROSS	SWRH Φ0.3		
75	138LR4012A	SPRING-TENSION	SWP Φ3.2		
76	138LR4015A	SPRING-PRESSURE	SWP Φ2.0		
77	111LR4004A	BOLT-CORE	S45C SNC3		

SVC Parts List

RSL-380

No.	Part No.	Part Name	Spec.	CHANGING REMARK	
				P NO.	DATE
78	381LR4051A	WIRE-HEATER, LINK	UL1015 AWG#18, BLK		
79	141LR4018A	BRACKET-SENSOR	SPCC 1.6T		
80	141LR4037A	PLATE-SENSOR	SUS		

6. Explode View

6.1 RSL-2701 Explode View

Frame L

Frame R

Frame, Roller and Other View

Wire, Front Table ,Film Shaft and Control PCB

6.2 RSL-380 Explode View

Frame L

Frame R

Frame, Roller and Other View

Wire, Front Table and Safety Cover

6.1 RSL-2701/2701U Expolde View

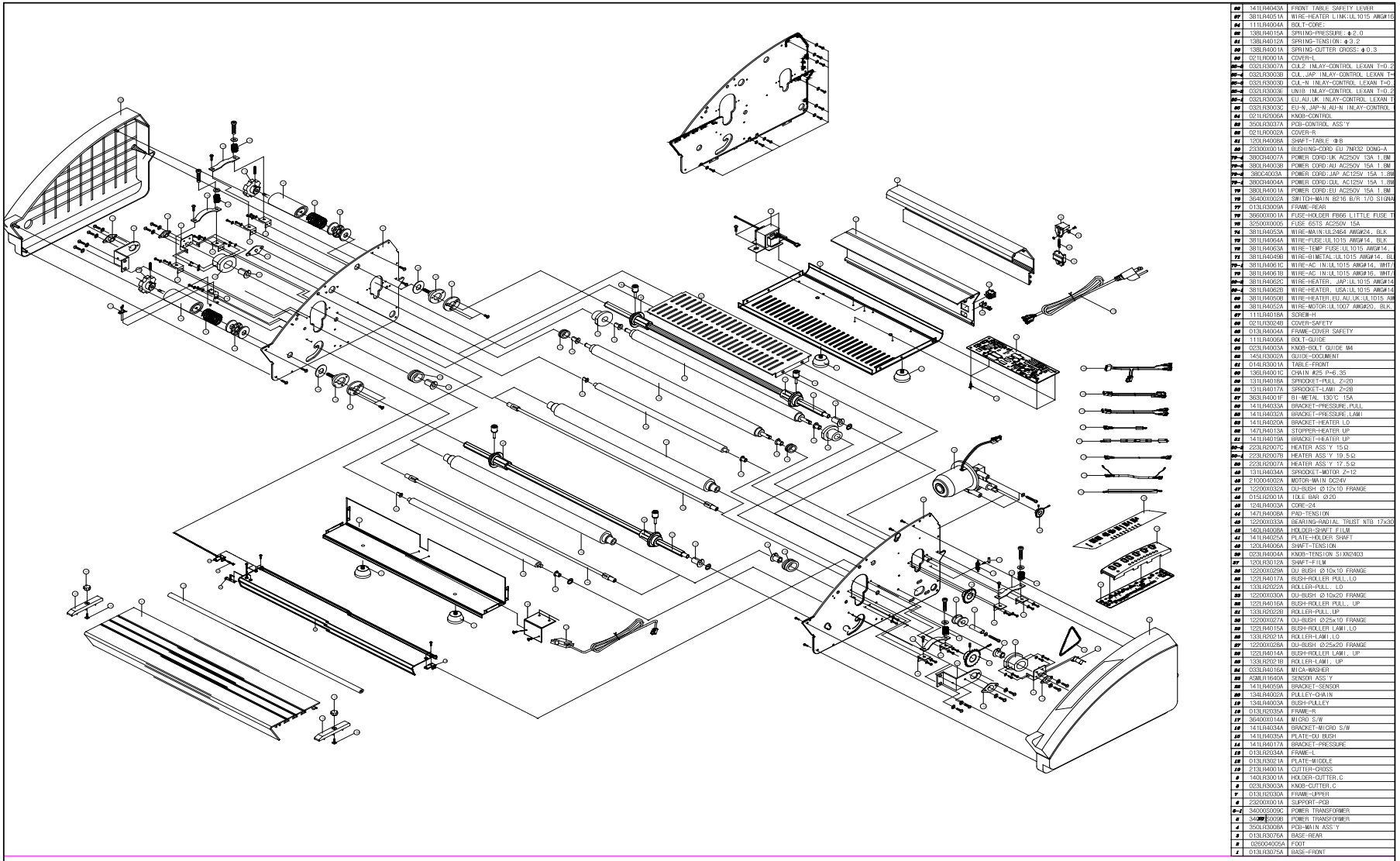

Frame - L

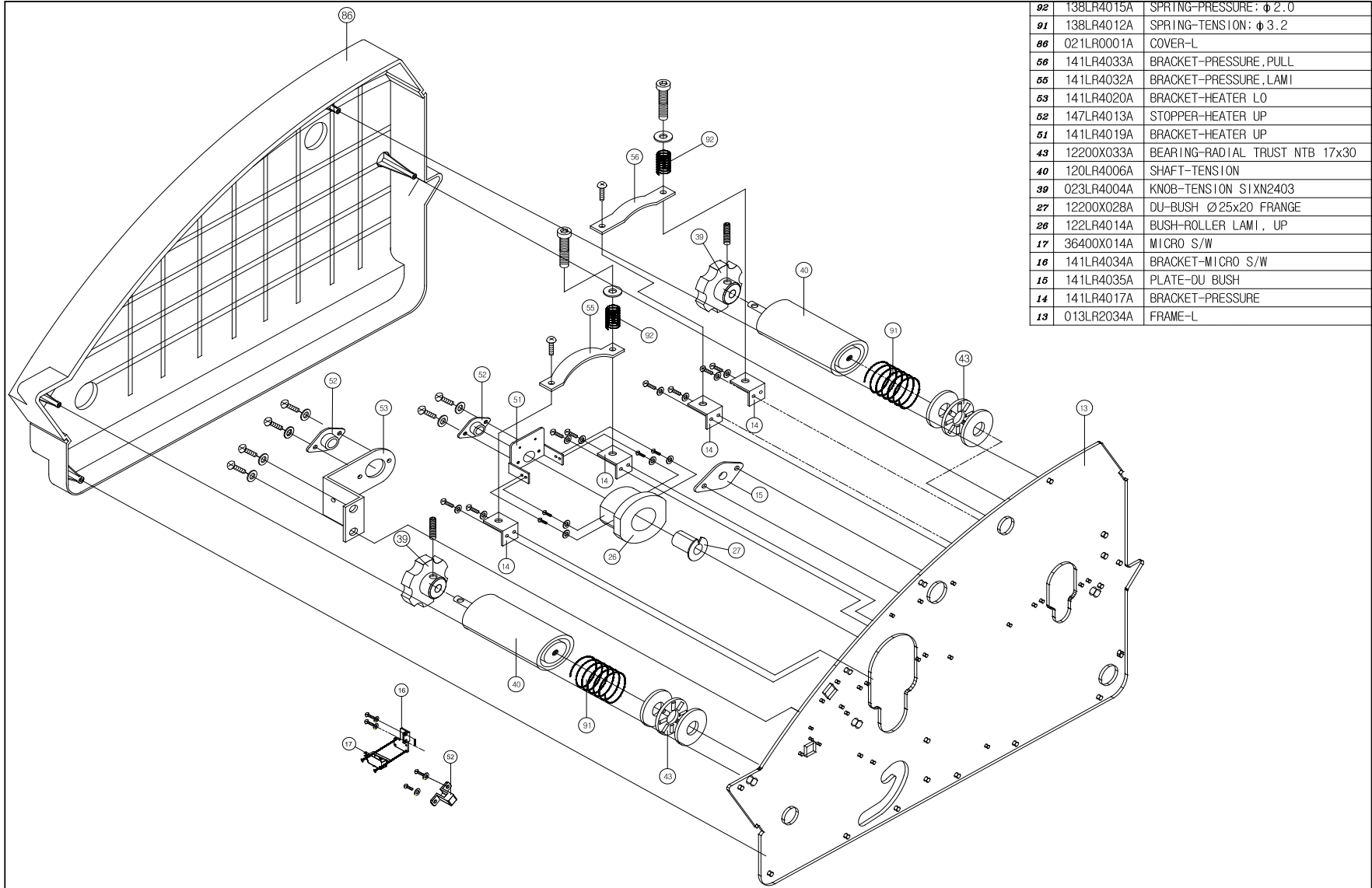

92	138LR4015A	SPRING-PRESSURE: ϕ 2.0
91	138LR4012A	SPRING-TENSION: ϕ 3.2
86	021LR0001A	COVER-L
56	141LR4033A	BRACKET-PRESSURE, PULL
55	141LR4032A	BRACKET-PRESSURE, LAMI
53	141LR4020A	BRACKET-HEATER LO
52	147LR4013A	STOPPER-HEATER UP
51	141LR4019A	BRACKET-HEATER UP
43	12200X033A	BEARING-RADIAL TRUST NTB 17x30
40	120LR4006A	SHAFT-TENSION
39	023LR4004A	KNOB-TENSION SIXN2403
27	12200X028A	DU-BUSH ϕ 25x20 FRANGE
26	122LR4014A	BUSH-ROLLER LAMI, UP
17	36400X014A	MICRO S/W
18	141LR4034A	BRACKET-MICRO S/W
16	141LR4035A	PLATE-DU BUSH
14	141LR4017A	BRACKET-PRESSURE
13	013LR2034A	FRAME-L

Frame - R

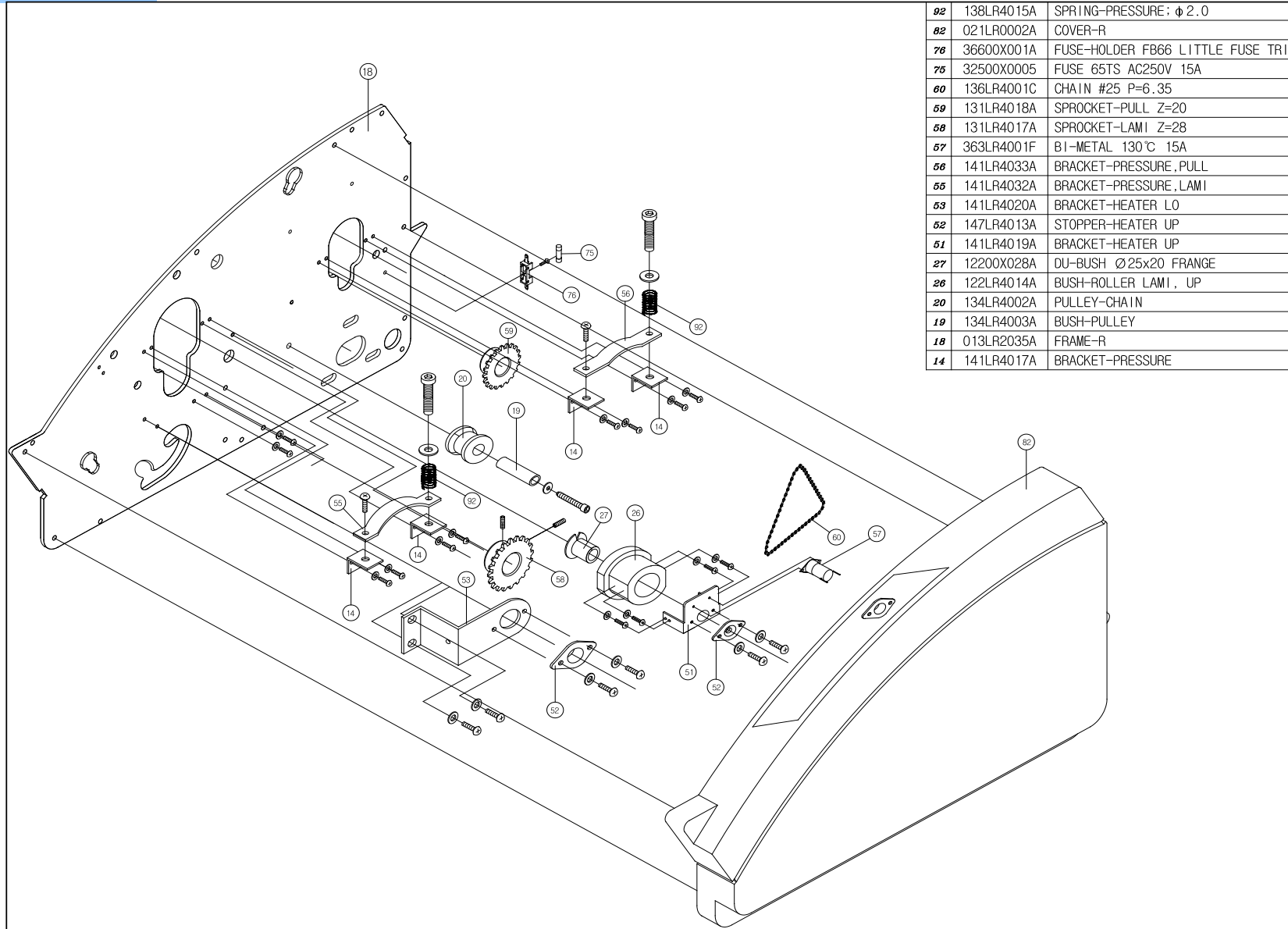

Frame, Roller and Other View

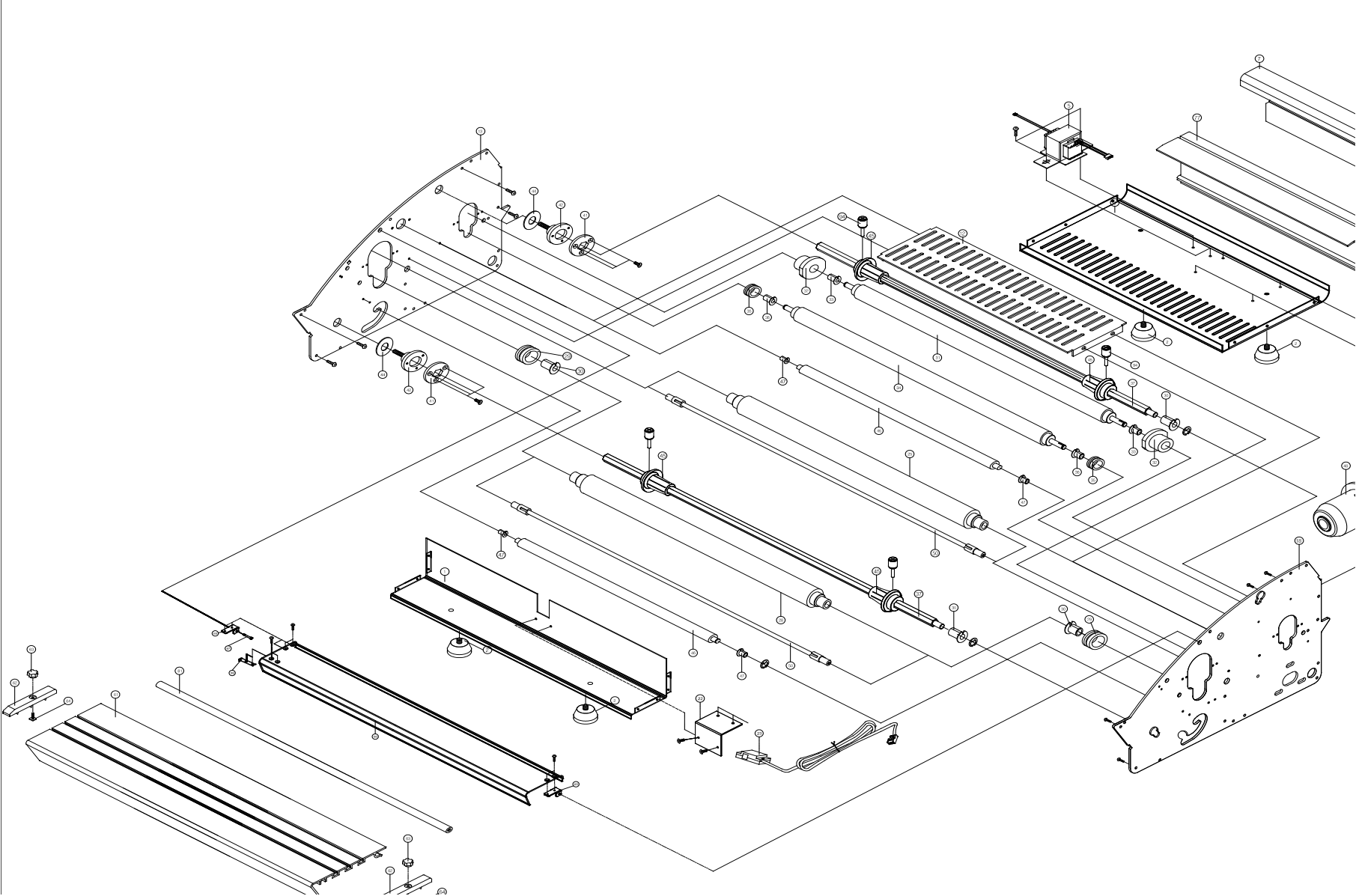

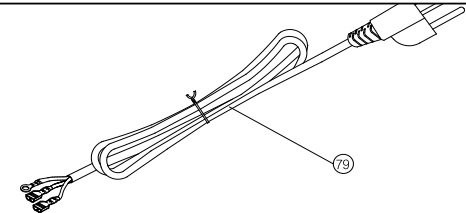
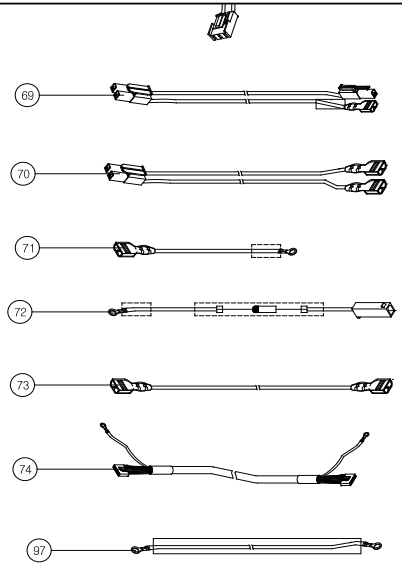
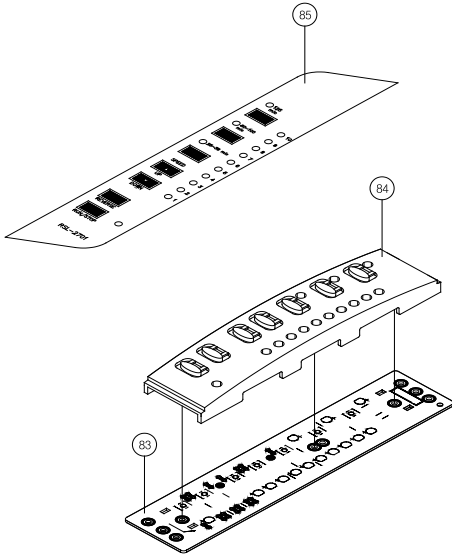

97	381LR4051A	WIRE-HEATER LINK:UL1015 AWG#16	BLK	2
85-6	032LR3007A	CUL2 INLAY-CONTROL LEXAN T=0.2	PC	1
85-4	032LR3003B	CUL, JAP INLAY-CONTROL LEXAN T=0.2	PC	1
85-3	032LR3003D	CUL-N INLAY-CONTROL LEXAN T=0.2	PC	1
85-2	032LR3003E	UN1B INLAY-CONTROL LEXAN T=0.2	PC	1
85-1	032LR3003A	EU, AU, UK INLAY-CONTROL LEXAN T=0.2	PC	1
85	032LR3003C	EU-N, JAP-N, AU-N INLAY-CONTROL LEXAN T=0.2	PC	1
84	021LR2006A	KNOB-CONTROL	AF-912	1
83	350LR3037A	PCB-CONTROL ASS'Y	FR-4	1
79-4	380CR4007A	POWER CORD:UK AC250V 13A 1.8M	-	1
79-3	380LR4003B	POWER CORD:AU AC250V 15A 1.8M	-	1
79-2	380C4003A	POWER CORD:JAP AC125V 15A 1.8M	-	1
79-1	380CR4004A	POWER CORD:CUL AC125V 15A 1.8M	-	1
79	380LR4001A	POWER CORD:EU AC250V 15A 1.8M	-	1
74	381LR4053A	WIRE-MAIN:UL2464 AWG#24, BLK	-	1
73	381LR4064A	WIRE-FUSE:UL1015 AWG#14, BLK	-	1
72	381LR4063A	WIRE-TEMP FUSE:UL1015 AWG#14, RED	-	1
71	381LR4049B	WIRE-BIMETAL:UL1015 AWG#14, BLK	-	1
70-1	381LR4061C	WIRE-AC IN:UL1015 AWG#14, WHT/BLK	-	1
70	381LR4061B	WIRE-AC IN:UL1015 AWG#16, WHT/BLK	-	1
69-2	381LR4062C	WIRE-HEATER, JAP:UL1015 AWG#14, WHT	-	1
69-1	381LR4062B	WIRE-HEATER, USA:UL1015 AWG#14, WHT	-	1
69	381LR4050B	WIRE-HEATER, EU, AU, UK:UL1015 AWG#14, WHT	-	1
68	381LR4052A	WIRE-MOTOR:UL1007 AWG#20, BLK, RED	-	1

6.2 RSL-380 Explode View

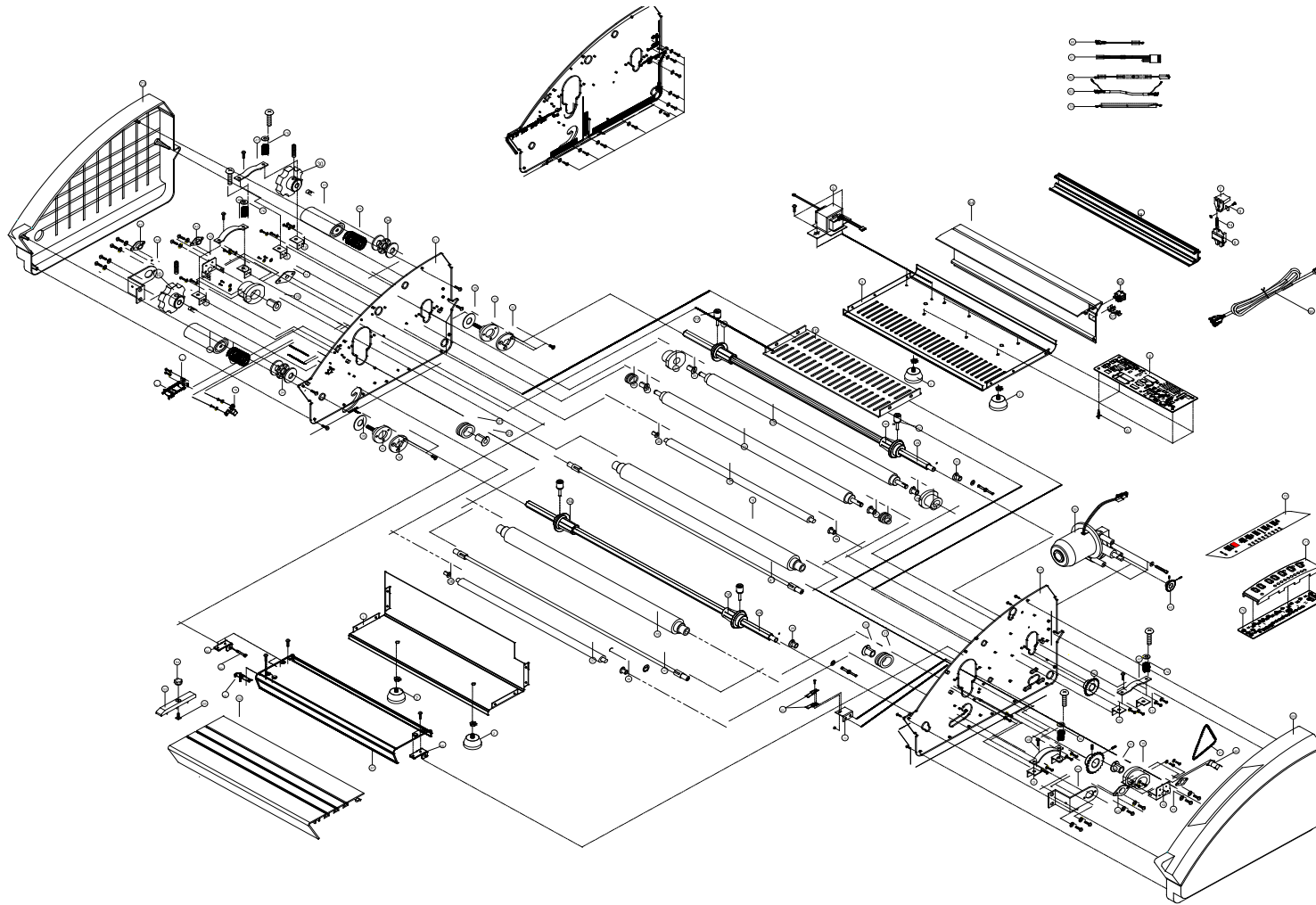

80	141LR4037A	PLATE-SENSOR
79	141LR4016A	BRACKET-SENSOR
78	381LR4051A	WIRE-HEATER LINK
77	111LR4004A	BOLT-CORE
76	138LR4015A	SPRING-PRESSURE
75	138LR4012A	SPRING-TENSION
74	138LR4001A	SPRING-CUTTER CROSS
73	021LR0001A	COVER-L
2	032LR3003G	CUL INLAY-CONTROL
72	032LR3003F	INLAY-CONTROL
71	021LR2006A	KNOB-CONTROL
70	350LR3009A	PCB-CONTROL ASSY
69	021LR0002A	COVER-R
68	013LR3002H	FRAME-CUTTER
67	2330X001A	BUSHING-CORD
6	380CR4007A	POWER CORD
6	380LR4003B	POWER CORD
6	380CR4003A	POWER CORD
6	380LR4001A	POWER CORD
6	380CR4004A	POWER CORD
6	380LR4002B	POWER CORD
65	3640X002B	SWITCH-MAIN
64	013LR3036A	FRAME-REAR
63	381LR4053A	WIRE-MAIN
62	381LR4063A	WIRE-TEMP FUSE
61	313005004A	SIN90GR
60	381LR4045A	WIRE-BIMETAL
59	111LR4018A	SCREEN4H
58	141LR4043A	FRONT TABLE SAFETY LEVER
57	021LR3024A	COVER-SAFETY
56	013LR4004A	FRAME-COVER SAFETY
55	111LR4006A	KNOB-GUIDE
54	023LR4002A	KNOB-BOLT GUIDE
53	145LR3002A	GUIDE-DOCUMENT
52	014LR3001B	TABLE-FRONT
51	138LR4001F	CHAIN
50	131LR4033A	SPROCKET-PULL
49	131LR4017A	SPROCKET-LAMI
48	363LR4001E	BI-METAL
47	141LR4033A	BRACKET-PRESSURE.PULL
46	141LR4032A	BRACKET-PRESSURE.LAMI
44	141LR4020A	BRACKET-HEATER LO
43	141LR4013A	STOPPER-HEATER UP
42	141LR4019A	BRACKET-HEATER UP
1	223LR3001F	HEATER ASSY 16.70 JAP
1	223LR3001E	HEATER ASSY 24Q CUL.UK
41	223LR3001D	HEATER ASSY 20.20 EU.AU.CH.KR
40	131LR4021A	SPROCKET-MOTOR
39	210004002A	MOTOR-MAIN
38	12200X032A	DU-BUSH
37	015LR2002A	IDLE BAR
36	124LR4003A	CORE-2H
35	147LR4008A	PAD-TENSION
34	12200X033A	BEARING-RADIAL TRUST
33	140LR4008A	HOLDER-SHAFT FILM
32	141LR4025A	PLATE-HOLDER SHAFT
31	120LR4006A	SHAFT-TENSION
30	023LR4004A	KNOB-TENSION
29	12200X002A	DU BUSH
28	120LR3020A	SHAFT-FILM
27	12200X029A	DU BUSH
26	122LR4047A	BUSH-ROLLER PULL.LO
25	12200X030A	DU-BUSH
24	122LR4043A	BUSH-ROLLER PULL. UP
3	133LR3005A	ROLLER-PULL UP
23	133LR3004A	ROLLER-PULL
22	12200X027A	DU-BUSH
21	122LR4045A	BUSH-ROLLER LAMI.LO
20	12200X028A	DU-BUSH
19	122LR4044A	BUSH-ROLLER LAMI. UP
18	133LR3001A	ROLLER-LAMI
17	013LR3068A	FRAME-R
16	021LR4001A	LIMIT SWITCH COVER
15	3640X014B	MICRO SW
14	141LR4050A	BRACKET-LIMIT SWITCH
13	141LR4035A	PLATE-DU BUSH
12	141LR4017A	BRACKET-PRESSURE
11	013LR3067A	FRAME-L
10	013LR3035A	PLATE-MIDDLE
9	213LR4001A	CUTTER-CROSS
8	140LR3001A	HOLDER-CUTTER.C
7	021CR3001A	KNOB-CUTTER.C
6	23200X001A	SUPPORT-PCB
5	340005009C	POWER TRANSFORMER JAP
5	340005009B	POWER TRANSFORMER
4	350LR3008C	PCB-MAIN ASS'Y EU AU KR SH UK
4	350LR3008D	PCB-MAIN ASS'Y CUL JAP
3	013LR3070A	BASE-REAR
2	026004005A	FOOT
1	013LR3069A	BASE-FRONT
NO	PART NO	DESCRIPTION

Frame - L

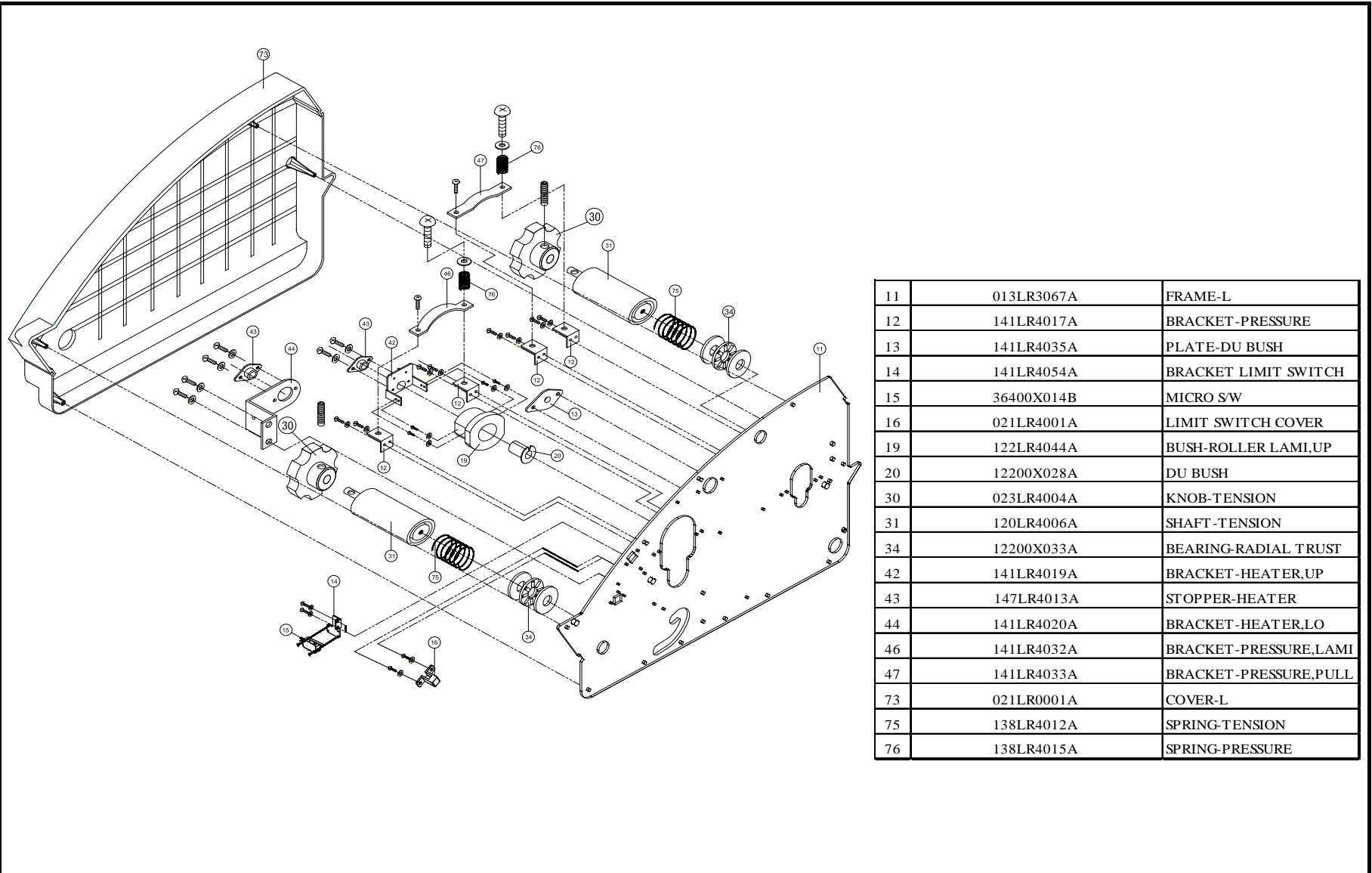

11	013LR3067A	FRAME-L
12	141LR4017A	BRACKET-PRESSURE
13	141LR4035A	PLATE-DU BUSH
14	141LR4054A	BRACKET LIMIT SWITCH
15	36400X014B	MICRO S/W
16	021LR4001A	LIMIT SWITCH COVER
19	122LR4044A	BUSH-ROLLER LAMI,UP
20	12200X028A	DU BUSH
30	023LR4004A	KNOB-TENSION
31	120LR4006A	SHAFT-TENSION
34	12200X033A	BEARING-RADIAL TRUST
42	141LR4019A	BRACKET-HEATER,UP
43	147LR4013A	STOPPER-HEATER
44	141LR4020A	BRACKET-HEATER,LO
46	141LR4032A	BRACKET-PRESSURE,LAMI
47	141LR4033A	BRACKET-PRESSURE,PULL
73	021LR0001A	COVER-L
75	138LR4012A	SPRING-TENSION
76	138LR4015A	SPRING-PRESSURE

Frame - R

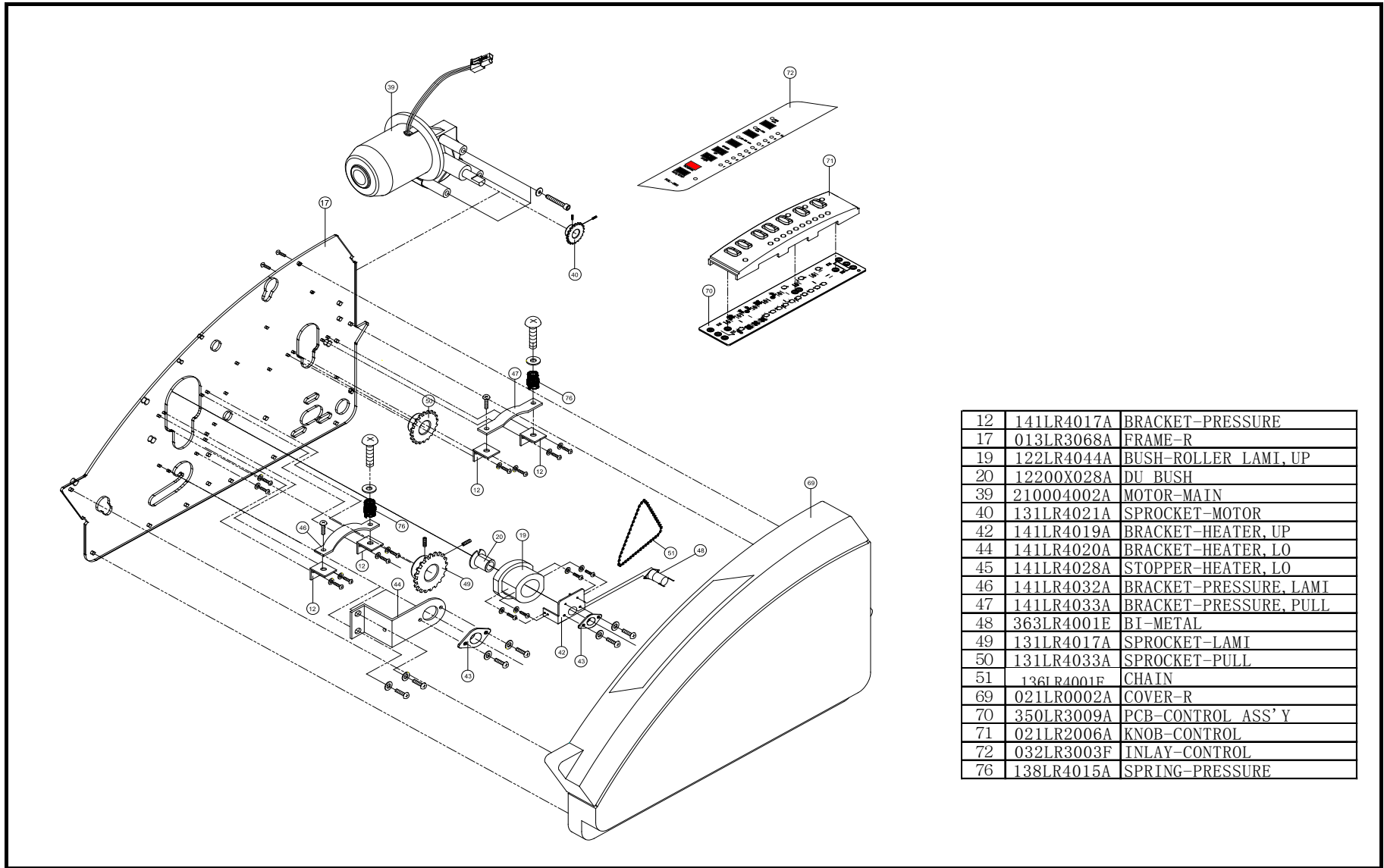

12	141LR4017A	BRACKET-PRESSURE
17	013LR3068A	FRAME-R
19	122LR4044A	BUSH-ROLLER LAMI, UP
20	12200X028A	DU BUSH
39	210004002A	MOTOR-MAIN
40	131LR4021A	SPROCKET-MOTOR
42	141LR4019A	BRACKET-HEATER, UP
44	141LR4020A	BRACKET-HEATER, LO
45	141LR4028A	STOPPER-HEATER, LO
46	141LR4032A	BRACKET-PRESSURE, LAMI
47	141LR4033A	BRACKET-PRESSURE, PULL
48	363LR4001E	BI-METAL
49	131LR4017A	SPROCKET-LAMI
50	131LR4033A	SPROCKET-PULL
51	136LR4001E	CHAIN
69	021LR0002A	COVER-R
70	350LR3009A	PCB-CONTROL ASS'Y
71	021LR2006A	KNOB-CONTROL
72	032LR3003F	INLAY-CONTROL
76	138LR4015A	SPRING-PRESSURE

Frame, Roller and Other View

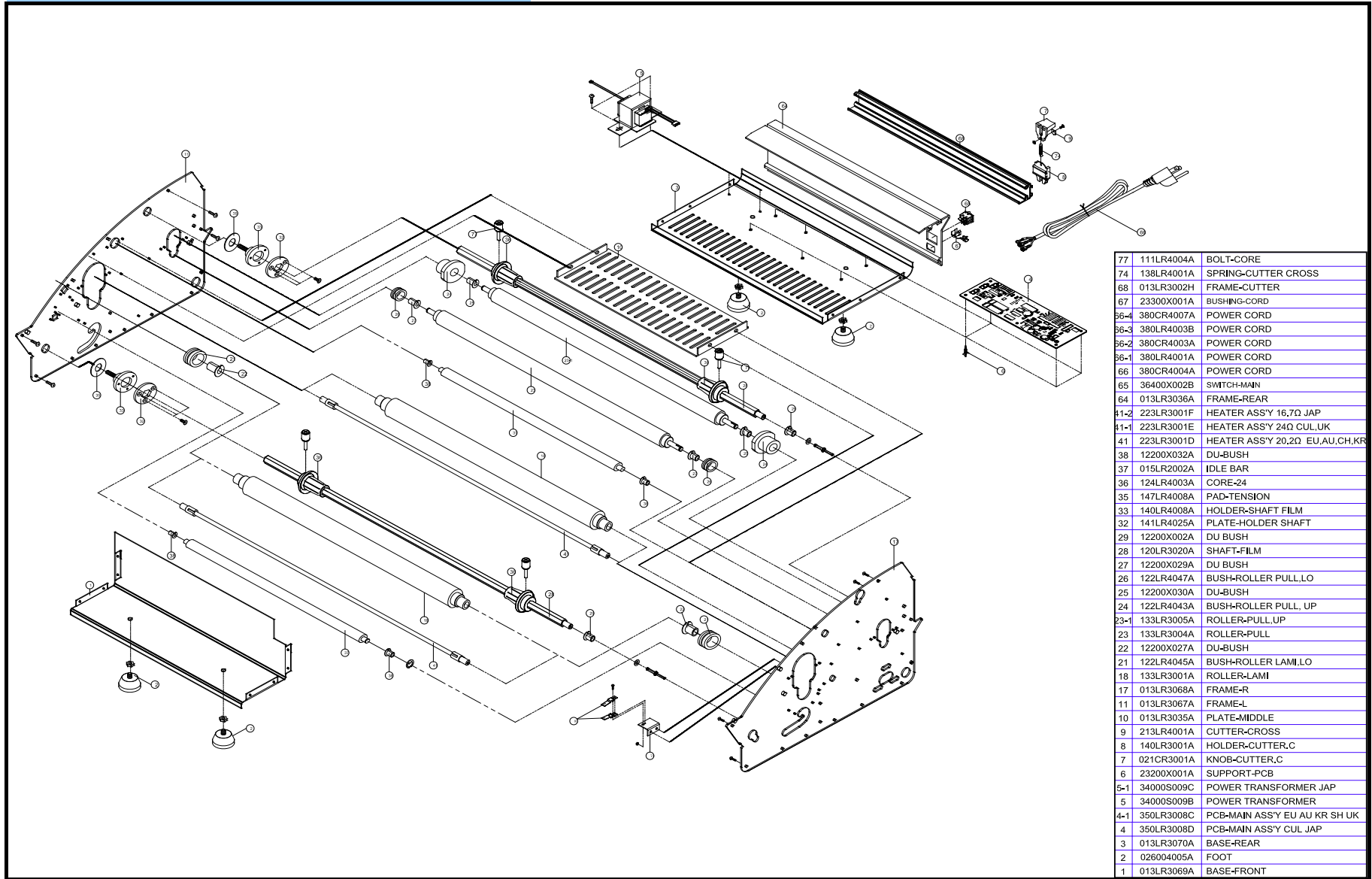

Wire, Front Table and Safety Cover

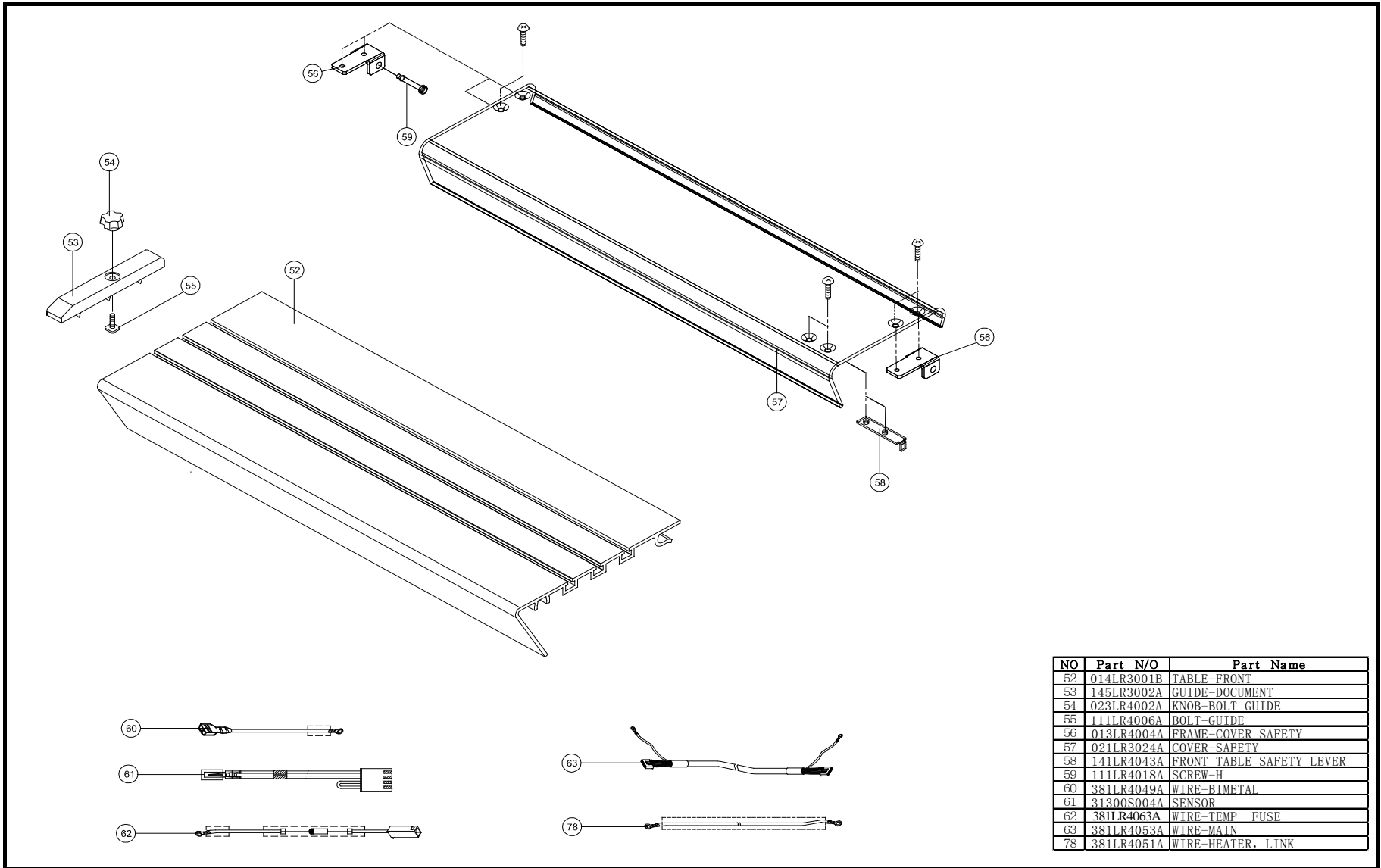

NO	Part N/O	Part Name
52	014LR3001B	TABLE-FRONT
53	145LR3002A	GUIDE-DOCUMENT
54	023LR4002A	KNOB-BOLT GUIDE
55	111LR4006A	BOLT-GUIDE
56	013LR4004A	FRAME-COVER SAFETY
57	021LR3024A	COVER-SAFETY
58	141LR4043A	FRONT TABLE SAFETY LEVER
59	111LR4018A	SCREW-H
60	381LR4049A	WIRE-BIMETAL
61	31300S004A	SENSOR
62	381LR4063A	WIRE-TEMP FUSE
63	381LR4053A	WIRE-MAIN
78	381LR4051A	WIRE-HEATER. LINK

7. RSL-2701/2701U/380 Wire Diagram

AC 100 ~ 120V WIRE DIAGRAM

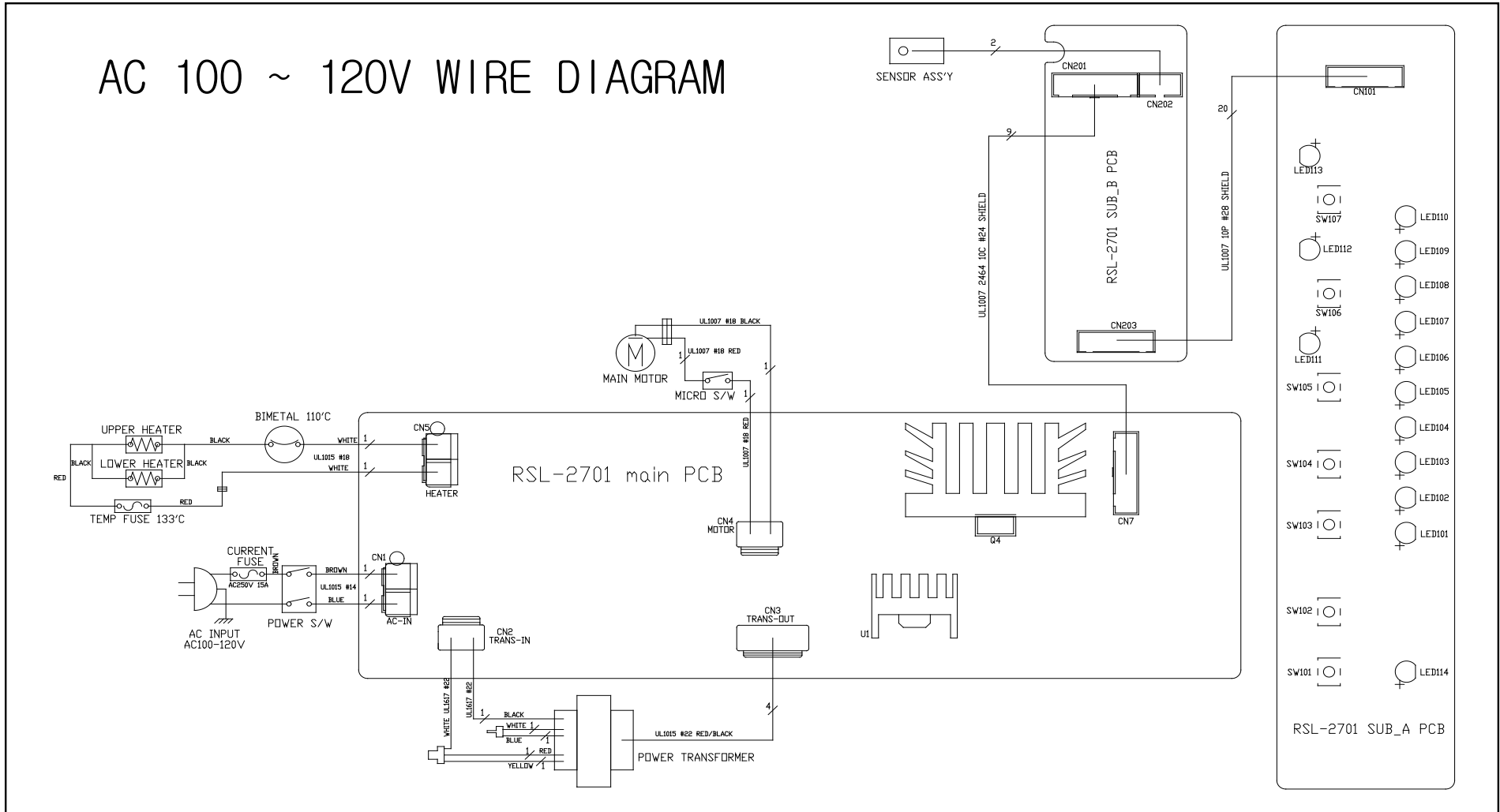

AC 220 ~ 240V WIRE DIAGRAM

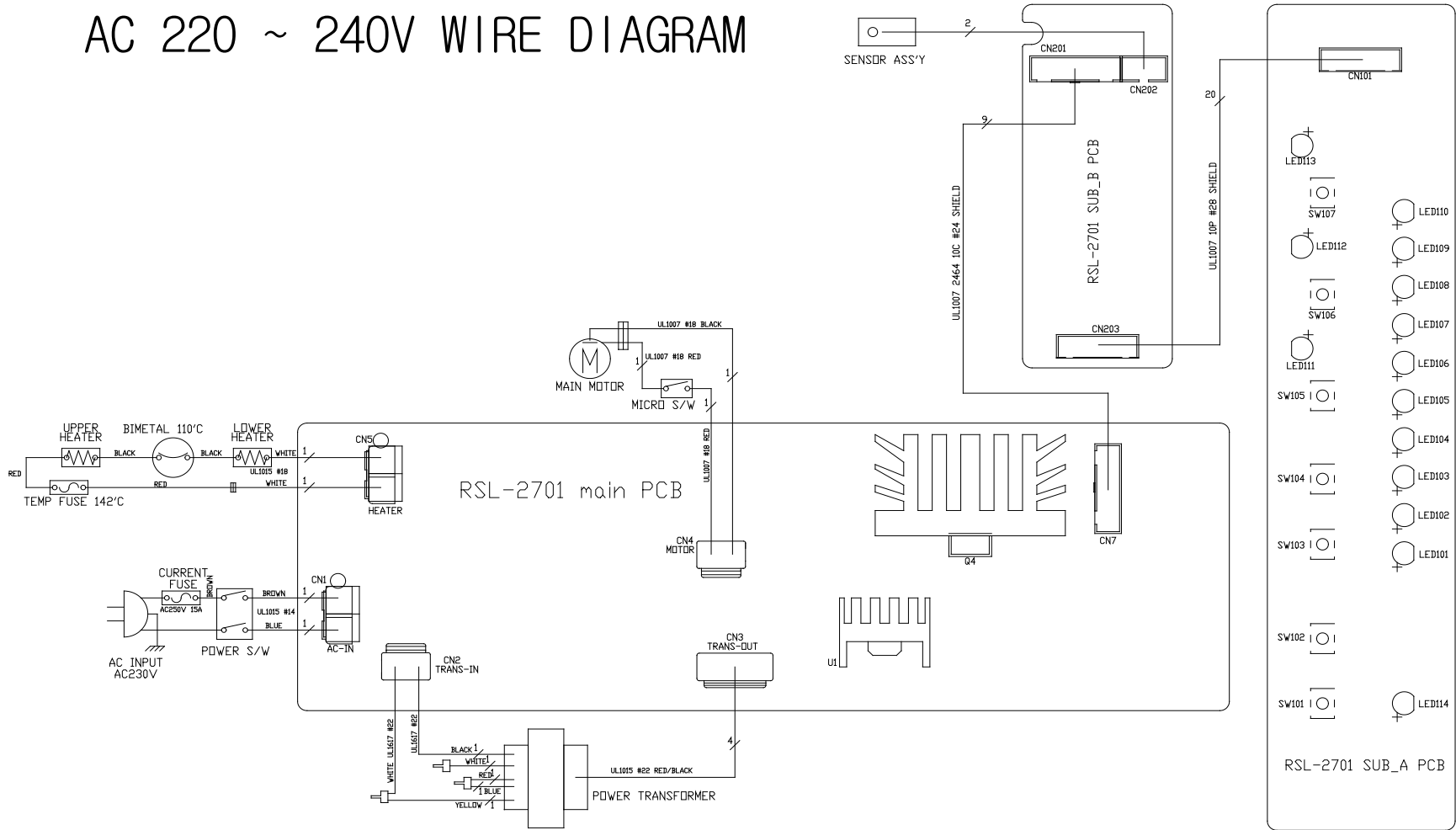

< MAIN PCB Layout >

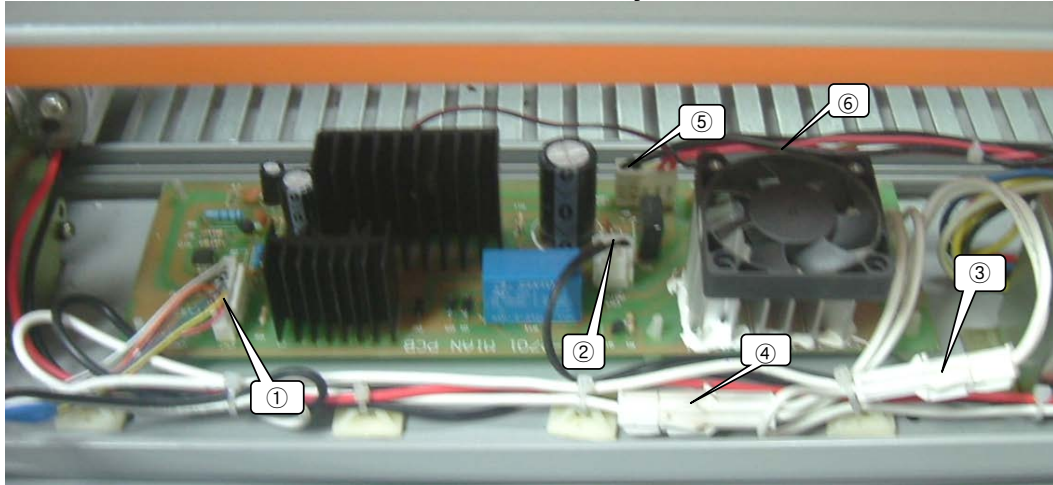

<Connect part>

1. WIRE-MAIN : above photo① →connect SUB PCB.
2. WIRE-MOTOR: above photo ② →connect the motor main.
3. WIRE-HEATER : above photo③ → connect HEATER ASS'Y.
4. WIRE-AC IN : above photo④ → connect MAIN SWITCH.
5. POWER TRANSFORMER. WIRE : above photo⑤, ⑥ → connect POWER TRANSFORMER.

<SUB PCB Layout >

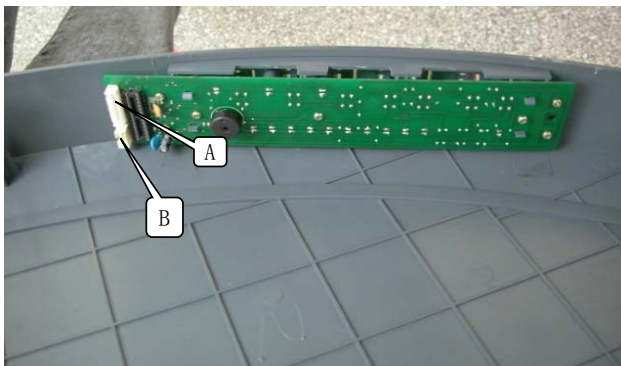

<connect part>

1. WIRE MAIN : above photo "<MAIN PCB Layout>" ① → connect above photo "<SUB-PCB Layout>" A.
2. WIRE SENSOR: above photo " B " with sensor Ass'y.

<POWER CORD Layout >

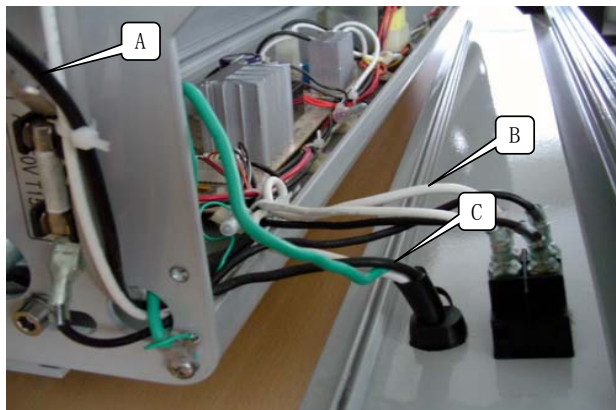

<connect part>

1. Connect above photo "A" with Main S/W, connect above photo "C" with Main Fuse, connect above photo "B" with Frame-R (Earth).

<FRAME-R Layout> ; 100 ~ 120V

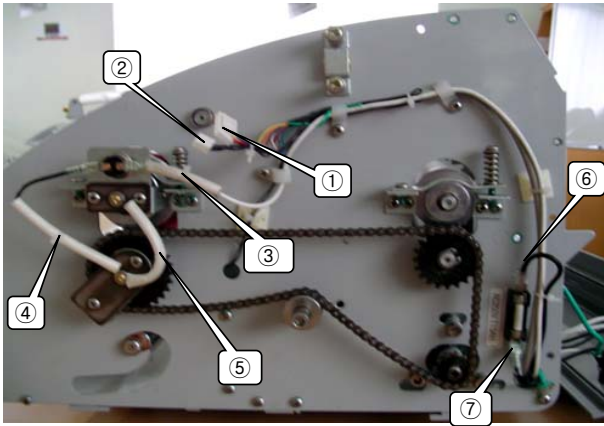

1. WIRE-MAIN : above photo ① → connect above photo "<SUB-PCB Layout>" ①
2. SENSOR WIRE : above photo ② → connect above photo "<SUB PCB Layout>" ②
3. WIRE-HEATER : above photo ③ → connect above photo BI-METAL.
4. WIRE-BI METAL : above photo ④ → connect BI-METAL with HEATER.
5. WIRE-HEATER LINK : above photo ⑤ → connect upper HEATER with lower HEATER
6. POWER CORD : above photo ⑥ → connect MAIN FUSE
7. WIRE-FUSE : above photo ⑦ → connect MAIN FUSE with MAIN S/W

<FRAME-R Layout> ; 220 ~ 240V

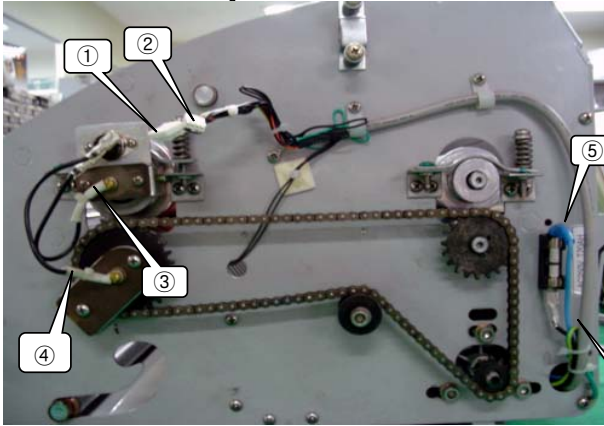

1. WIRE-MAIN : above photo ① → connect above photo "<SUB-PCB Layout>" ①
2. SENSOR WIRE : above photo ② → connect above photo "<SUB PCB Layout>" ②
3. WIRE-BI METAL : above photo ③ → connect BI-METAL with Heater.
4. WIRE-BI METAL : above photo ④ → connect BI-METAL with Heater.
5. POWER CORD : above photo ⑤ → connect Main Fuse
6. WIRE-FUSE : above photo ⑥ → connect Main Fuse with Main S/W

<FRAME-L Layout>;100~120V

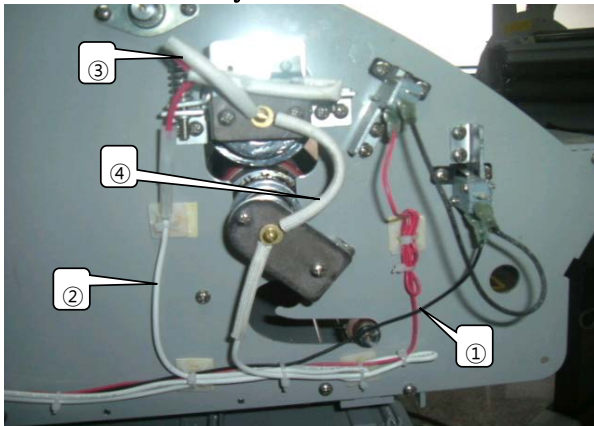

<connect part>

1. WIRE-MOTOR : above photo ① → connect Micro S/W
2. WIRE-HEATER : above photo ② → connect above photo ③ with Wire-Temp Fuse
3. WIRE-TEMP FUSE : above photo ③ → connect lower Heater
4. WIRE-HEATER LINK : above photo ④ → connect lower Heater with upper Heater

<FRAME-L Layout>;220~240V

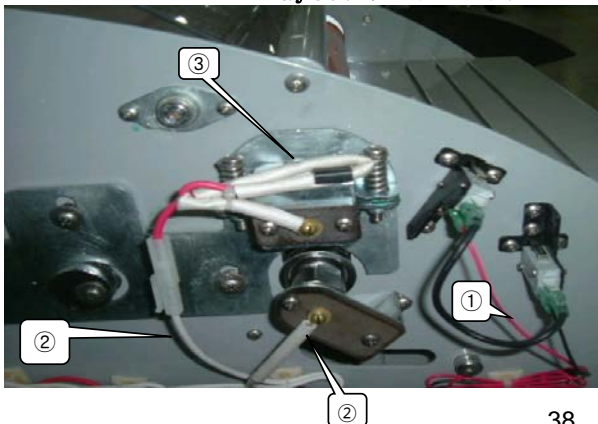

<connect part>

1. WIRE-MOTOR : above photo ① → connect Micro S/W
2. WIRE-HEATER : above photo ② → connect Wire-Temp Fuse and lower Heater
3. WIRE-TEMP FUSE : above photo ③ → connect upper Heater