



T310c Access Point Quick Setup Guide

NOTE: The minimum software revision for the T310c is ZoneDirector (ZD) 10.1 or later, or SmartZone (SZ) 3.6 or later, or standalone AP firmware 108.0 or later.

This Quick Setup Guide provides step-by-step instructions on how to field-install the Ruckus Wireless T310c access point (AP). For detailed information on planning the installation, performing a site survey, and operating the T310c, refer to the *Ruckus Wireless Outdoor Access Point User Guide*, available at <https://support.ruckuswireless.com>.

WARNING! Only trained and qualified personnel should be allowed to install, replace, or service this equipment.

WARNING! Installation of this equipment must comply with local and national electrical codes.

CAUTION! Make sure that you form a 80mm - 130mm (3"-5") drip loop in any cable that is attached to the AP or the building. This will prevent water from running along the cable and entering the AP or the building where the cable terminates.

CAUTION! Be sure that grounding is available and that it meets local and national electrical codes. For additional lightning protection, use lightning rods and lightning arrestors.

CAUTION! Make sure that proper lightning surge protection precautions are taken according to local electrical code.

WARNING! Ruckus Wireless strongly recommends that you wear eye protection before mounting the T310c.

This Guide in Other Languages

- 从以下网站得指南的体中文版 <https://support.ruckuswireless.com>.
- Vous trouverez la version française de ce guide à l'adresse suivante <https://support.ruckuswireless.com>.

- このガイドの日本語版は <https://support.ruckuswireless.com> でご覧ください。
- 이 가이드의 한국어 버전은 웹 사이트 (<https://support.ruckuswireless.com>) 에서 확인하시기 바랍니다.
- Veja a versão em português (Brasil) deste guia em <https://support.ruckuswireless.com>.
- Puede ver la versión en español (América Latina) de esta guía en <https://support.ruckuswireless.com>.

Before You Begin

Before deploying Ruckus Wireless products, please check for the latest software and the release documentation.

- Release Notes and other user documentation are available at <http://support.ruckuswireless.com/documents>.
- Software upgrades are available at <http://support.ruckuswireless.com/software>.
- Open source information is available at <http://opensource.ruckuswireless.com>.
- Software license and limited warranty information are available at <http://support.ruckuswireless.com/warranty>.

Before deploying your Ruckus Wireless Access Point, verify that all items listed in *Package Contents* are included in the package. If any item is damaged or missing, notify your authorized Ruckus Wireless sales representative. Also, make sure that you have the required hardware and tools.

Required Hardware and Tools

- No. 2 Phillips screwdriver
- Small flat-blade screwdriver
- Torque wrench or torque screwdriver with sockets
- Long-nose pliers
- Electrical wire stripping and terminal crimping pliers
- Pipe or pole --OR-- a sturdy flat surface
- Electric drill with drill bits and customer-supplied wall anchors, flat washers, and hex nuts for flat-surface mount

Package Contents

A complete T310c field installation package includes all of the items listed below (see Figure below for illustrations):

- T310c Access Point (A)
- M25 data cable gland (B)
- Ground wire with lug (C)
- Pole/Wall Mount Bracket Kit (D)
- Four steel pipe clamps
- Service Level Agreement/Limited Warranty Statement

- Declaration of Conformity
- Regulatory Statement
- Ruckus Wireless AP Getting Started Guide
- This Quick Setup Guide

FIGURE 1 T310c Package Contents

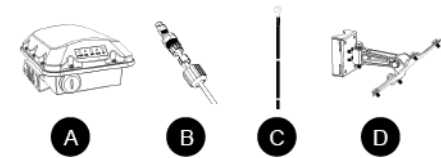

Mounting Instructions

Connecting And Sealing the RJ-45 Cables

Connect and seal the RJ-45 cable(s) using the M25 data cable glands shown in the Figure below.

WARNING! Do not use any PoE injector not tested and approved by Ruckus Wireless to power the T310c Access Point.

FIGURE 2 T310c LEDs and Ports

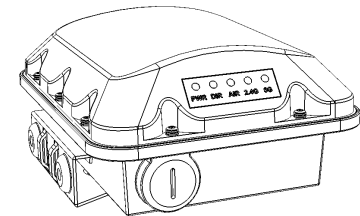

1. Feed the end of the cable through the sealing nut, rubber O-ring, clamping ring assembly and cable gland base as shown.

NOTE: Do not seat the clamping ring and rubber O-ring into the gland body until the gland body has been torqued to spec.

FIGURE 3 RJ-45 cable and cable gland assembly

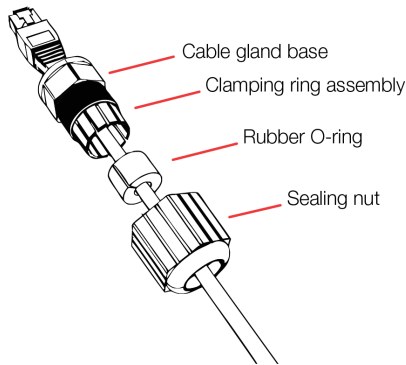

2. Use a wide flat-blade screwdriver to remove the required (PoE IN) blanking cap from the AP.
3. Connect the cable to the Ethernet port on the AP.
4. Tighten the cable gland base into the AP chassis to 7 N.m or 62 in-lbs.
5. Wrap the clamping ring assembly around the rubber O-ring. Make sure that the clamping ring assembly fully encloses the rubber O-ring.
6. Seat the clamping ring assembly and rubber O-ring in the cable gland base.
7. Hand-tighten the sealing nut.

Attaching the Mounting Bracket To A Flat Surface

1. The AP mounting bracket attaches to the AP using a captive screw. Use a medium flat-blade or No. 2 Phillips screwdriver to loosen the captive screw (A in the Figure below) and pull up on the end of the bracket to remove the bracket from the AP (B in the Figure below).

FIGURE 4 Removing the mounting bracket

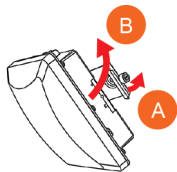

2. Using either of the two options shown in Figure 5, hold the mounting bracket at the location on the mounting surface where you want to mount the AP. Use the holes

on the mounting bracket as a template to mark the locations of the mounting holes.

NOTE: The mounting bracket can be mounted to a vertical or horizontal surface to support the AP in the required orientation.

FIGURE 5 Mounting bracket on a flat surface



3. Remove the mounting bracket from the mounting surface.
4. Drill holes required for the customer-supplied mounting hardware.
5. Attach the mounting bracket to the flat surface using the mounting hardware.
6. Using the mounting hardware instructions, tighten the hardware to secure the mounting bracket.
7. Continue with Mounting the AP.

Attaching the Mounting Bracket to a Pole

1. The AP mounting bracket attaches to the AP using a captive screw. Loosen the screw (A in Figure 4) and pull up on the end of the bracket to remove the bracket from the AP (B in the Figure above).
2. Insert the open end of one steel clamp (D in the Figure above) into two of the slots on the mounting bracket.

NOTE: The mounting bracket can be mounted to a vertical or horizontal pole to support the AP in the required orientation.

3. Using either of the two options shown, use the clamp(s) to attach the mounting bracket to the pole. Tighten the clamps to 3 N.m or 27 in-lbs, or per manufacturer's specifications if the factory-supplied clamps are not used.
4. If necessary, daisy-chain the other steel clamps to accommodate larger poles.

FIGURE 6 Mounting bracket on a pole



5. Continue with Mounting the AP.

Mounting the AP

1. Snap the AP back onto the mounting bracket (A in the Figure below), and use a medium flat-blade or No. 2 Phillips screwdriver to tighten the captive screw to 1.1 N.m or 10 in-lbs to secure the bracket to the AP (B).

FIGURE 7 Attaching the mounting bracket to the AP

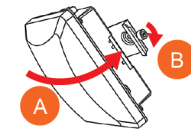

2. Optional Step: If you also need to lock the mounting bracket to the AP, then use a matching security screwdriver to screw the customer-supplied locking stainless steel 6mm M3 panhead security screw through the mounting bracket and into the AP chassis.

CAUTION! Make sure that the customer-supplied locking stainless steel M3 panhead security screw is no longer than 6mm. If the security screw is longer than 6mm, it can damage the AP chassis.

FIGURE 8 Locking the mounting bracket to the AP

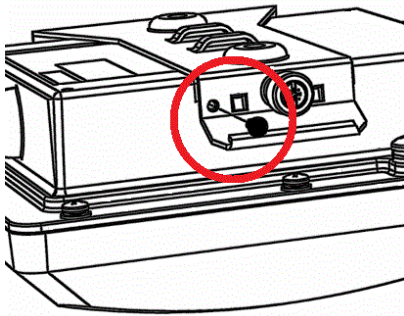

You have completed mounting the AP to the mounting bracket.

Earth Grounding the AP

CAUTION! Make sure that earth grounding is available and that it meets local and national electrical codes. For additional lightning protection, use lightning rods and lightning arrestors.

NOTE: The color coding of ground wires varies by region. Before completing this step, check your local wiring standards for guidance.

Using the factory-supplied ground wire and ground screw/washer set, connect a good earth ground to the AP chassis ground point.

CAUTION! The T310c AP includes one 9mm stainless steel M6x1 earth ground screw with split lock and flat washers. Make sure that any replacement screw is no longer than 9mm. If a screw is longer than 9mm, it can damage the AP chassis.

FIGURE 9 Connect good earth ground to AP here

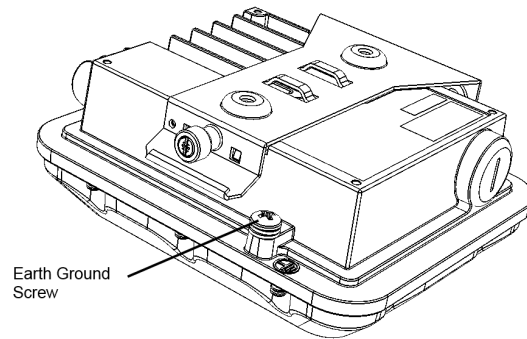

Congratulations! You have mounted your T310c access point.

Troubleshooting

CAUTION! If required, you can reset the AP to its factory default settings by pressing the reset button located inside the PoE IN port. **DO NOT DO THIS UNLESS SO INSTRUCTED.** (Doing this resets the AP IP address to 192.168.0.1.)

NOTE: After a reset, you can access the internal AP web interface using <https://192.168.0.1>. Your device must use any other address from 192.168.0.2 through 192.168.0.254, with subnet mask 255.255.255.0. The username is super, and the password is sp-admin. Refer to the *Outdoor Access Point User Guide* for information on configuring and operating the AP. This document is available at <https://support.ruckuswireless.com>.

For More Information

For information on how to configure and manage the AP, refer to the *Ruckus Wireless Outdoor Access Point User Guide*, available from <https://support.ruckuswireless.com>.