



# T504 Strand Mount Concurrent AP with Integrated Cable Modem

## Installation Guide

DRAFT

Part Number 800-70610-001 Rev A  
Draft Published December 2, 2014

[www.ruckuswireless.com](http://www.ruckuswireless.com)

## Copyright Notice and Proprietary Information

Copyright 2014. Ruckus Wireless, Inc. All rights reserved.

No part of this documentation may be used, reproduced, transmitted, or translated, in any form or by any means, electronic, mechanical, manual, optical, or otherwise, without prior written permission of Ruckus Wireless, Inc. ("Ruckus"), or as expressly provided by under license from Ruckus.

### Destination Control Statement

Technical data contained in this publication may be subject to the export control laws of the United States of America. Disclosure to nationals of other countries contrary to United States law is prohibited. It is the reader's responsibility to determine the applicable regulations and to comply with them.

### Disclaimer

THIS DOCUMENTATION AND ALL INFORMATION CONTAINED HEREIN ("MATERIAL") IS PROVIDED FOR GENERAL INFORMATION PURPOSES ONLY. RUCKUS AND ITS LICENSORS MAKE NO WARRANTY OF ANY KIND, EXPRESS OR IMPLIED, WITH REGARD TO THE MATERIAL, INCLUDING, BUT NOT LIMITED TO, THE IMPLIED WARRANTIES OF MERCHANTABILITY, NON-INFRINGEMENT AND FITNESS FOR A PARTICULAR PURPOSE, OR THAT THE MATERIAL IS ERROR-FREE, ACCURATE OR RELIABLE. RUCKUS RESERVES THE RIGHT TO MAKE CHANGES OR UPDATES TO THE MATERIAL AT ANY TIME.

### Limitation of Liability

IN NO EVENT SHALL RUCKUS BE LIABLE FOR ANY DIRECT, INDIRECT, INCIDENTAL, SPECIAL OR CONSEQUENTIAL DAMAGES, OR DAMAGES FOR LOSS OF PROFITS, REVENUE, DATA OR USE, INCURRED BY YOU OR ANY THIRD PARTY, WHETHER IN AN ACTION IN CONTRACT OR TORT, ARISING FROM YOUR ACCESS TO, OR USE OF, THE MATERIAL.

### Trademarks

Ruckus Wireless, Ruckus, Bark Logo, Simply Better Wireless are trademarks of Ruckus Wireless, Inc. in the United States and other countries. All other product or company names may be trademarks of their respective owners.

# Contents

## 1 About This Installation Guide

Using this Installation Guide . . . . .	7
Terms Used in This Guide . . . . .	9
Related Documentation . . . . .	9
Documentation Feedback . . . . .	10

## 2 Planning the T504 Installation

T504 Omni Antenna Coverage . . . . .	12
Powering Options . . . . .	13
Performing a Site Survey . . . . .	13

## 3 Installing the T504

Safety Information . . . . .	16
Unpacking the T504 . . . . .	17
Package Contents . . . . .	17
Finding the AP and CM MAC Addresses . . . . .	17
Connectors and Ground Point . . . . .	18
LEDs and Reset Button/Diagnostic Ethernet Port . . . . .	19
Dimensions . . . . .	20
Deploying the T504 . . . . .	21
Mounting the T504 . . . . .	21
Earth Grounding the T504 . . . . .	21
Installing the Cable Power Tap . . . . .	22
Powering the T504 with POC . . . . .	22
Checking the Signal Level with an RF Power Meter (Optional) . . . . .	24
Configuring the T504 for the First Time (Optional) . . . . .	25
Preparing the Administrative Computer . . . . .	25
Operating the CM . . . . .	27
Configuring the AP for Standalone Operation . . . . .	34
Verifying CM and AP Operation . . . . .	37

## 4 Operating and Troubleshooting the T504

Retrieving the CM's MAC Address . . . . .	38
Retrieving the CM's MAC Address . . . . .	38

Retrieving the CM's MAC Address using the CM CLI . . . . .	38
Retrieving the CM's MAC Address using the AP CLI . . . . .	39
Rebooting and Resetting the T504 . . . . .	39
How Radio Frequency Scanning Works . . . . .	40

## 5 What to Do Next

Changing the Administrative Password . . . . .	41
Configuring the Security Settings . . . . .	41
Configuring Advanced Settings and Features . . . . .	41
Reading Related Documentation. . . . .	41

## Appendix A: Ruckus Wireless Factory- and Customer-Supplied Parts

### Appendix B: Rebooting and Resetting the T504

Rebooting and Resetting the AP and CM . . . . .	43
Using the Reset Button Inside the AP. . . . .	43
Remotely Rebooting the AP . . . . .	44
Resetting the CM to Factory Default Settings . . . . .	45

### Appendix C: T504 Mounting Dimensions and Weight

Dimensions. . . . .	46
Weight . . . . .	48

DRAFT

# About This Installation Guide

# 1

This *Installation Guide* provides information on how to set up the Ruckus Wireless Strand Mount Concurrent Access Point with Integrated Cable Modem (T504) on your network. Topics covered in this guide include basic configuration, operation and mounting. The rest of this document refers to the Strand Mount Concurrent Access Point with Integrated Cable Modem as the **T504**.

This guide is intended for use by those installing and configuring network equipment. Consequently, it assumes a basic working knowledge of local area networking, cable modem setup and configuration, wireless networking, and wireless devices.

Figure 1. Typical T504 mounted on a strand



## Using this Installation Guide

The T504 installation is completed with five main steps. Each step includes some substeps. [Figure 2](#) shows the main steps, and [Table 1](#) includes the substeps.

Figure 2. Adding a T504 to an existing Ruckus Wireless network flowchart

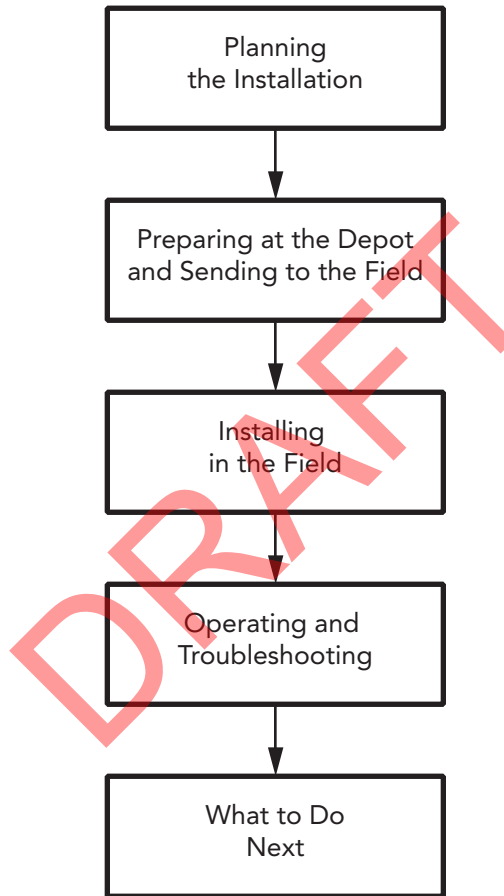

Table 1. Adding a T504 to an Existing Ruckus Wireless network

Section	Heading
2	<a href="#">Planning the T504 Installation</a> <ul style="list-style-type: none"> <li>• T504 Omni Antenna Coverage</li> <li>• Powering Options</li> <li>• Performing a Site Survey</li> </ul>
3	<a href="#">Installing the T504</a> <ul style="list-style-type: none"> <li>• Safety Information</li> <li>• Unpacking the T504</li> <li>• Finding the AP and CM MAC Addresses</li> <li>• Connectors and Ground Point</li> <li>• LEDs and Reset Button/Diagnostic Ethernet Port</li> <li>• Dimensions</li> <li>• Deploying the T504</li> <li>• Verifying CM and AP Operation</li> </ul>
4	<a href="#">Operating and Troubleshooting the T504</a> <ul style="list-style-type: none"> <li>• Retrieving the CM's MAC Address</li> <li>• Rebooting and Resetting the T504</li> <li>• How Radio Frequency Scanning Works</li> </ul>
5	<a href="#">What to Do Next</a> <ul style="list-style-type: none"> <li>• Changing the Administrative Password</li> <li>• Configuring the Security Settings</li> <li>• Configuring Advanced Settings and Features</li> <li>• Reading Related Documentation</li> </ul>

**NOTE** The AP part of the T504 can be managed using an AP web browser interface, an AP command line interface (CLI), and a simple network management protocol (SNMP) interface.

## Terms Used in This Guide

Before continuing, Ruckus Wireless recommends that you become familiar with the following terms:

- *T504*: T504 Cable Modem Access Point, which includes the CM and AP and the cable strand interface.
- *AP*: The Wi-Fi Access Point part of the T504 Cable Modem Access Point.
- *CM*: The Cable Modem part of the T504 Cable Modem Access Point.
- *CMTS*: Cable modem termination system high speed data services equipment.
- *HFC*: Hybrid fiber coax broadband network.
- *MSO*: Multiple system operator.

## Related Documentation

In addition to this guide, each Cable Modem Access Point documentation set includes the following:

- *User Guide*: Provides detailed information on how to configure the functions of the unit. The User Guide is available for download on the Ruckus Wireless Support Web site at <http://support.ruckuswireless.com/documents>
- *Release Notes*: Provides late-breaking information about the current software release, including new features, enhancements, and known issues. If the information in the Release Notes differs from the information in this guide, follow the instructions in the Release Notes.
- *Online Help*: Accessible from the T504's Web interface, the Online Help provides information that helps you configure the device from the Web interface.



# Documentation Feedback

Ruckus Wireless is interested in improving its documentation and welcomes your comments and suggestions. You can email your comments to Ruckus Wireless at [docs@ruckuswireless.com](mailto:docs@ruckuswireless.com)

When contacting us, please include the following information:

- Document title
- Document part number (on the cover page)
- Page number (if appropriate)

For example:

- T504 Strand Mount Concurrent AP with Integrated CM Installation Guide
- Part number: 800-70610-001 Rev A
- Page 11

DRAFT

# Planning the T504 Installation

# 2

Before installing the T504, verify the version and plan the AP installation. In this chapter:

- [T504 Omni Antenna Coverage](#)
- [Powering Options](#)
- [Performing a Site Survey](#)

DRAFT

## T504 Omni Antenna Coverage

The T504 (ordering part number 975-T504-US31) includes internal 5GHz and 2.4GHz omnidirectional antennas, and is equipped with a DOCSIS 3.0 cable modem.

The T504s are best deployed where internal-antenna lateral beamforming can provide the greatest reach and throughput to a wide coverage area, and provide the greatest distance between APs in a connecting device. See [Figure 3](#) for internal-antenna coverage patterns.

Figure 3. Omni 5GHz and 2.4GHz coverage

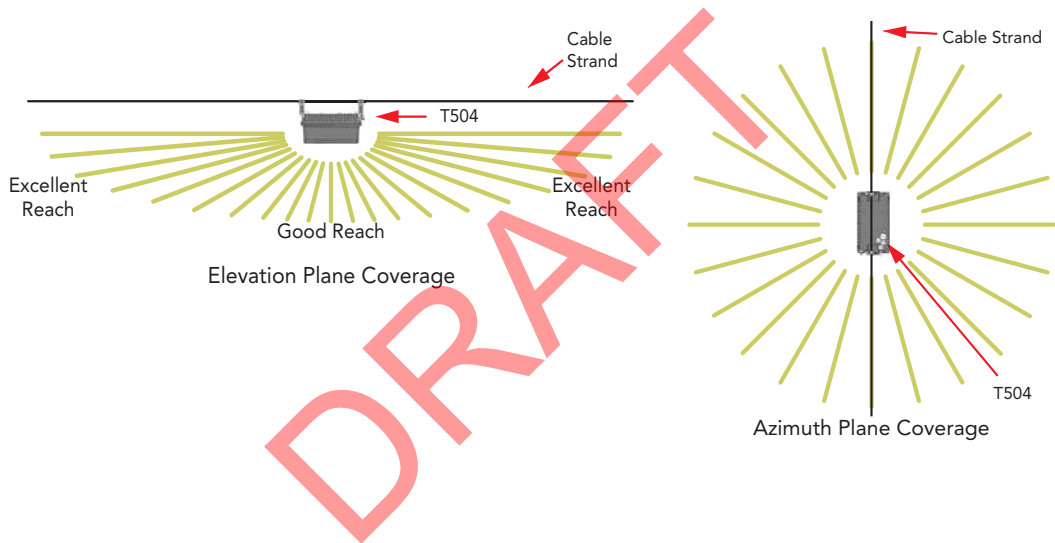

## Powering Options

The T504 supports AC power over cable (POC). 40 to 90 VAC POC is used when the T504 is mounted on a cable strand and powered via an F-type coaxial cable connected to the HFC cable plant.

## Performing a Site Survey

Perform a site survey to determine the optimal T504 placement for maximum range, coverage, and network performance. Ruckus Wireless Support can supply Site Survey best practices information.

The location and orientation that you choose for the T504 play a critical role in the performance of your wireless network. In general, Ruckus Wireless recommends installing the T504 away from obstructions and sources of interference and ensuring that the AP's best coverage zone is pointing in the general direction of its wireless clients or associated bridge units as described in [T504 Omni Antenna Coverage](#).

When performing a site survey, consider the following factors:

- *Data rates:* Range is generally inversely proportional to data rates. The maximum radio range is achieved at the lowest workable data rate. Higher data rates are generally achieved at closer distances.
- *Antenna type and placement:* Proper antenna configuration is a critical factor in maximizing radio range. As a general rule, radio range is increased by mounting the radio higher off of the ground with the AP oriented so that the dome is tilted down. (For recommended orientation examples, refer to [T504 Omni Antenna Coverage](#).)
- *Physical environment:* Clear or open areas provide better radio range than crowded or filled areas. The less cluttered the operating environment, the greater the wireless range.
- *Obstructions, building materials, and sources of interference:* Physical obstructions, such as concrete pillars, steel beams, buildings and trees, can block or hinder wireless communication. Avoid installing the T504 in an environment where there is an obstruction between sending and receiving devices. A number of machines and electronic devices that emit radio waves – cranes, wireless phones, microwave ovens, satellite dishes – interfere with and block wireless signals. Building materials used in construction also influence radio signal penetration. For example, drywall construction permits greater range than concrete blocks.

- *Mounting:* The T504 is designed to clamp onto a 1/4" to 3/8" (6.35mm to 10mm) support wire. The hangers allow a 2" bundle of cables between the support wire and the T504.
- *Power and backhaul connections:* The T504 needs a backhaul connection to the CMTS and it needs to be close enough to an AC power inserter on the CATV cable to assure that it is able to pull 20 watts at greater than 40 VAC. If not, then another power inserter must be installed closer to the T504.

When you are done planning the T504 installation, continue with [Installing the T504](#).

DRAFT

# Installing the T504

# 3

Before installing the T504, Ruckus Wireless recommends that you first complete the procedures described in [Planning the T504 Installation](#).

In this chapter:

- [Safety Information](#)
- [Unpacking the T504](#)
- [Finding the AP and CM MAC Addresses](#)
- [Connectors and Ground Point](#)
- [LEDs and Reset Button/Diagnostic Ethernet Port](#)
- [Dimensions](#)
- [Deploying the T504](#)
- [Verifying CM and AP Operation](#)

DRAFT

## Safety Information

---

**WARNING!** Only trained and qualified installers should be allowed to install, replace, or service this equipment.

The professional installer is responsible for the proper installation and configuration of this AP. The AP installation must comply with local regulatory requirements, especially with those regulating operation near military and/or weather radar systems.

---

**WARNING!** Installation of this equipment must comply with local and national electrical codes.

---

**WARNING!** Ruckus Wireless strongly recommends that you wear eye protection before mounting the AP.

---

**CAUTION!** Make sure that you form a 80mm - 130mm (3" - 5") drip loop in any cable that is attached to the AP or other equipment. This will prevent water from running along the cable and entering the AP or other equipment.

---

**CAUTION!** Be sure that grounding is available and that it meets local and national electrical codes. For additional lightning protection, use lightning rods and lightning arrestors.

---

**CAUTION!** Make sure that proper lightning surge protection precautions are taken according to local electrical code.

---

## Unpacking the T504

- 1 Open the T504 package, and then carefully remove the contents.
- 2 Return all packing materials to the shipping box, and put the box away in a dry location.
- 3 Verify that all items listed in [Package Contents](#) are included in the package. Check each item for damage. If any item is damaged or missing, notify your authorized Ruckus Wireless sales representative.

---

**NOTE** [Appendix A: Ruckus Wireless Factory- and Customer-Supplied Parts](#) includes illustrations and descriptions of these and other factory-orderable and customer-supplied parts.

---

### Package Contents

A Ruckus Wireless T504 package contains the items listed below:

- Ruckus Wireless T504 unit with cable strand hangers, includes one 12mm stainless steel M6x1 earth ground panhead screw with split lock and flat washers
- One green/yellow earth ground wire with ring terminal
- Service Level Agreement/Limited Warranty Statement
- Regulatory Statement
- Declaration of Conformity, if required
- This *Installation Guide*

### Finding the AP and CM MAC Addresses

The T504 has separate MAC addresses for the internal AP and cable modem (CM), mounted on the end of the T504 with the F-type connector and the ground screw (see [Figure 4](#)).

Continue with [Connectors and Ground Point](#).



## Connectors and Ground Point

Figure 4 identifies the connector and external ground point on the T504. Table 2 describes this connector and the ground point.

Figure 4. T504 connectors and ground point

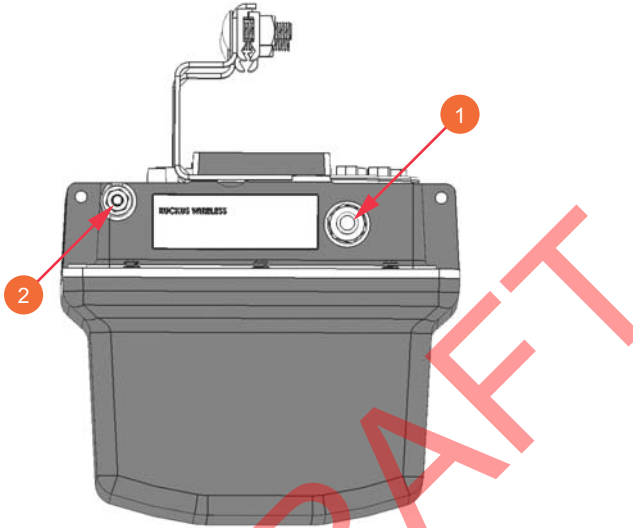

Table 2. Connectors and ground point on the T504

No.	Label	Description
1	Coaxial Cable Connector	Connects to the CMTS at the headend using a tap on the plant, and provides AC POC to the T504. For more information, refer to <a href="#">Powering Options</a> .
2	Optional External Earth Ground Point	The T504 is normally earth-grounded by the cable strand. However, if the cable strand is not earth grounded, then connect an external earth ground to the T504 using this screw-and-washer set.

## LEDs and Reset Button/Diagnostic Ethernet Port

Use the eight LEDs to check the status of the access point and cable modem. [Figure 5](#) shows the LEDs on the T504, and [Table 3](#) describes the LEDs and the reset button/diagnostic Ethernet port.

Figure 5. T504 LEDs and reset button/diagnostic Ethernet port when the dome is pointing downwards

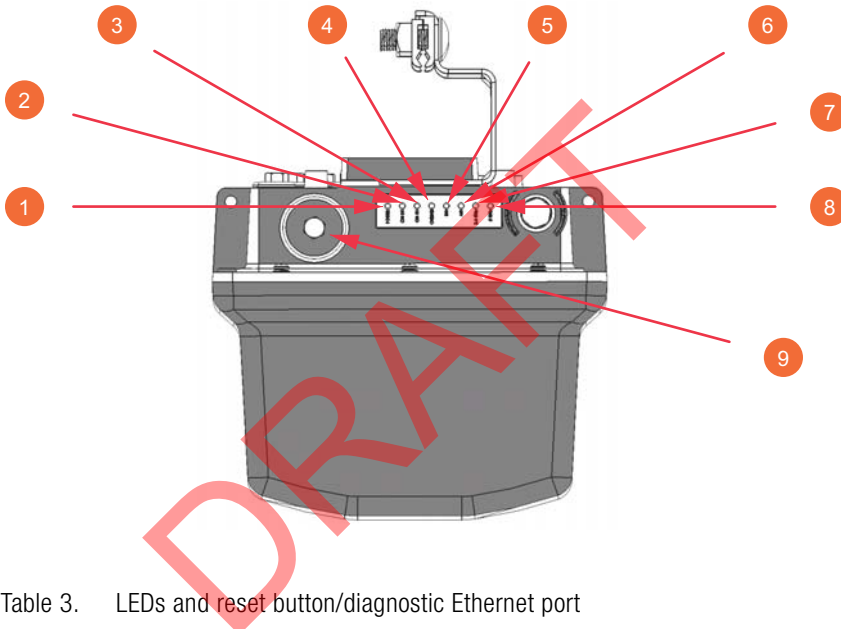

Table 3. LEDs and reset button/diagnostic Ethernet port

No.	Label	Description
1	POWER	<ul style="list-style-type: none"><li>• <i>Dark</i>: Off.</li><li>• <i>Red</i>: Boot up in process.</li><li>• <i>Green</i>: On.</li></ul>
2	CM DS	<ul style="list-style-type: none"><li>• Blinks when searching for downstream (DS), then solid when DS is locked. Also blinks during CM boot when power is applied.</li></ul>
3	CM US	<ul style="list-style-type: none"><li>• Off when DS is searching, and then blinks as upstream power is increased/ranged and then solid when upstream ranging is complete. Also blinks during CM boot when power is applied.</li></ul>

Table 3. LEDs and reset button/diagnostic Ethernet port (Continued)

No.	Label	Description
4	ONLINE	<ul style="list-style-type: none"> <li>Off until CM DS and CM US are solid ON, then blinks as the CM obtains an IP address and a configuration file, and then comes online and LED is solid. Also blinks during CM boot when power is applied.</li> </ul>
5	DIR	<ul style="list-style-type: none"> <li><i>Always Off:</i> The Access Point is not being managed by a Ruckus Wireless controller.</li> </ul>
6	AIR	<ul style="list-style-type: none"> <li><i>Off:</i> The Access Point is operating in standalone mode.</li> <li><i>Green:</i> The wireless signal to its uplink AP is good.</li> </ul>
7	2.4 GHz	<ul style="list-style-type: none"> <li><i>Off:</i> The WLAN service is down.</li> <li><i>Green:</i> The WLAN is up and at least one client is associated.</li> <li><i>Amber:</i> The WLAN is up. No clients are associated.</li> </ul>
8	5 GHz	<ul style="list-style-type: none"> <li><i>Off:</i> The WLAN service is down.</li> <li><i>Amber:</i> The WLAN is up, but no clients are associated/connected.</li> <li><i>Green:</i> The WLAN is up and at least one client is associated.</li> </ul>
9	--	<p>Reset button and diagnostic Ethernet port -- Use a 7/16" (11mm) wrench to remove the screw-in plug.</p> <ul style="list-style-type: none"> <li>After removing the plug, press the reset button for ten seconds to reset the AP part of the T504 to factory default.</li> </ul> <p><b>CAUTION: DO NOT DO THIS UNLESS SO INSTRUCTED.</b>  <i>Doing this resets the AP IP address to 192.168.100.2.</i></p> <ul style="list-style-type: none"> <li>After removing the plug, you can see the diagnostic Ethernet port. This port is used for diagnostics and/or initial configuration.</li> </ul>

## Dimensions

[“Appendix C: T504 Mounting Dimensions and Weight”](#) on page 46 contains the dimensions for the T504.

# Deploying the T504

In this section, you will mount the T504 in its final mounting location. Perform the following:

- [Mounting the T504](#)
- [Earth Grounding the T504](#)
- [Installing the Cable Power Tap](#)
- [Powering the T504 with POC](#)
- [Checking the Signal Level with an RF Power Meter \(Optional\)](#)
- [Configuring the T504 for the First Time \(Optional\)](#)

## Mounting the T504

To mount the T504 assembly on a cable strand, you need to secure the cable clamps that are attached to the strand interface to the cable strand.

- 1 Slightly loosen the nuts that fasten the two cable clamps to the strand interface, enough for the strand support cable to fit into the cable clamps.
- 2 Place the cable clamps on the strand support cable.
- 3 Tighten the two cable clamp nuts to 22 to 27 N.m (16 to 20 ft-lbs) to secure the mounting.

You have mounted the T504. Continue with [Earth Grounding the T504](#).

## Earth Grounding the T504

The cable strand is usually earth-grounded, and mounting the T504 on the cable strand earth grounds the T504 chassis as well; if this is the case, skip this procedure and continue with [Installing the Cable Power Tap](#).

---

**CAUTION!** Be sure that earth grounding is available and that it meets local and national electrical codes. For additional lightning protection, use lightning rods and lightning arrestors.

---

If the cable strand is not earth-grounded, then continue with the following:

- 1 The color coding of ground wires varies by region. Before completing this step, check your local wiring standards for guidance.
- 2 Using the factory-supplied ground screw and washers, use the factory-supplied earth ground wire with ring terminal to connect a good earth ground to the T504 using the chassis ground screw shown in [Figure 4](#).

**CAUTION!** The T504 includes one 12mm stainless steel M6x1 earth ground screw with split lock and flat washers. Make sure that any replacement screw is no longer than 12mm. If a screw is longer than 12mm, it can damage the T504 chassis.

You have earth-grounded the T504. Continue with [Installing the Cable Power Tap](#).

## Installing the Cable Power Tap

The CATV coaxial cable used in the field deployment must have 40 to 90 VAC power multiplexed with the RF signal on the coaxial cable, since the T504 Connector B is used for both electrical power and the RF signal.

Ruckus Wireless recommends installing a cable power tap (Antronix MGT2000-SDPE tap, or equivalent) close to the T504. Refer to the manufacturer's instructions to mount the cable power tap on the coaxial cable. [Figure 6](#) shows a typical cable power tap and connection to the CM using an RG6 quad shield cable.

Figure 6. Cable Power Tap Connection to the T504 Cable Modem

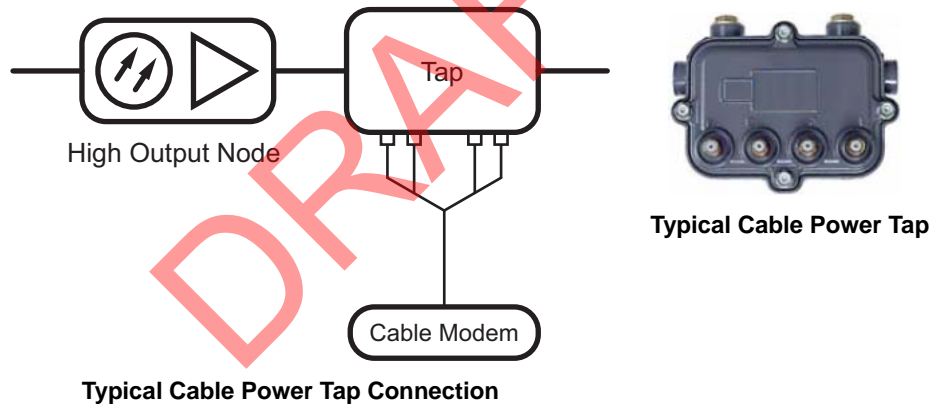

Continue with [Powering the T504 with POC](#).

## Powering the T504 with POC

40 to 90 VAC POC is used when the T504 is mounted on a cable strand and powered via an F-type coaxial cable connected to the HFC cable plant.

- 1 Remove the power jumper from the power tap to remove AC power out of the power tap.

- 2 Insert the F-type coaxial cable that is connected to the HFC cable plant to the F-type connector on the T504. Power is supplied through a power passing tap on the CATV coax. The tap is connected to F-type connector on the T504 as shown in [Figure 4](#).
- 3 Finger tighten the coaxial cable connector and then tighten to 3.4 N.m (30 in-lbs).
- 4 Plug the power jumper back into the power tap to restore AC power out of the power tap.
- 5 When the T504 receives power, its LEDs flash on and off as it goes through a power-on self test and then receives its AP and CM configurations from the cable operator.

---

**NOTE** Normally, the T504 receives its AP and CM configurations from the cable operator. This means that the installer does not need to manually configure either the AP or the CM part of the T504.

---

- 6 Wait until the T504 **PWR**, **CM DS**, **CM US**, and **ONLINE** LEDs stop flashing and then remain on.

You have verified that the T504 is powered. Continue with [Checking the Signal Level with an RF Power Meter \(Optional\)](#).

## Checking the Signal Level with an RF Power Meter (Optional)

The CMAP cable modem is just like the standard DOCSIS 3.0 modem installed at home.

Connect an RF power meter to the cable from the cable power tap.

Select a CATV power passing tap that supplies a signal level between -12 and +16dBmV at its output (prefer 0 to 6dBmV).

[Table 4](#) lists the signal level specifications to coaxial cable connector on the CMAP.

Table 4. Coaxial cable connector signal level specifications

Downstream	Upstream
-12 to +16dBmV/64 QAM --or-- -12 to +16dBmV/256 QAM	TDMA: (1xUpstream) <ul style="list-style-type: none"> <li>• Pmin to +57dBmV (32 QAM, 64 QAM)</li> <li>• Pmin to +58dBmV (8 QAM, 16 QAM)</li> <li>• Pmin to +58dBmV (QPSK)</li> </ul> S-CDMA: (1xUpstream) <ul style="list-style-type: none"> <li>• Pmin to +56dBmV (all modulations), where:</li> <li>• Pmin = +17dBmV, 1280kHz modulation rate</li> <li>• Pmin = +20dBmV, 2560kHz modulation rate</li> <li>• Pmin = +23dBmV, 5120kHz modulation rate</li> </ul> TDMA: (4xUpstream) <ul style="list-style-type: none"> <li>• Pmin to +51dBmV (32 QAM, 64 QAM)</li> <li>• Pmin to +52dBmV (8 QAM, 16 QAM)</li> <li>• Pmin to +55dBmV (QPSK)</li> </ul> S-CDMA: (4xUpstream) <ul style="list-style-type: none"> <li>• Pmin to +53dBmV (all modulations), where:</li> <li>• Pmin = +17dBmV, 1280kHz modulation rate</li> <li>• Pmin = +20dBmV, 2560kHz modulation rate</li> <li>• Pmin = +23dBmV, 5120kHz modulation rate</li> </ul>

Continue with [Configuring the T504 for the First Time \(Optional\)](#).

## Configuring the T504 for the First Time (Optional)

---

**NOTE** The T504 normally receives its latest AP and CM firmware downloads and initial configurations from the cable modem termination system high speed data services (CMTS) equipment when it powers up; if this is the case, then skip this section and continue with [Verifying CM and AP Operation](#).

---

If the T504 AP and CM do not receive their latest firmware downloads and initial configurations from the CMTS equipment when the T504 powers up, then continue with this procedure:

- [Preparing the Administrative Computer](#)
- [Operating the CM](#)
- [Configuring the AP for Standalone Operation](#)

### Preparing the Administrative Computer

Use an administrative computer to configure basic operational parameters for the T504 access point and cable modem parts.

---

**NOTE** The following procedure is applicable if the administrative computer is running Windows 7 or Windows XP. If you are using a different operating system, refer to the documentation that was shipped with your operating system for information on how to modify the computer's IP address settings.

---

- 1 Collect required equipment and information:
  - An administrative computer (notebook computer) running Windows 7/Vista/XP/2000 with one wireless 802.11b/g/n network card and one Ethernet card installed.
  - Mozilla Firefox 2.0 (or later) or Microsoft Internet Explorer 6.0 (or later) installed on the administrative computer.
  - A Telnet or SSH (secure shell) client program installed on the administrative computer.
- 2 On your Windows computer, open the **Network Connections** (or **Network and Dial-up Connections**) control panel according to how the *Start* menu is set up:
  - On Windows 7, click **Start > Control Panel > Network and Sharing Center > Change Adapter Settings**.
  - On Windows XP, click **Start > Control Panel > Network Connections**.
- 3 When the *Network Connections* window appears, right-click the icon for *Local Area Connection*, and then click **Properties**.



**NOTE** Make sure that you configure the *Local Area Connection* properties, not the *Wireless Network Connection* properties.

- 4 When the *Local Area Connection Properties* dialog box appears, select **Internet Protocol (TCP/IP)** or **TCP/IPv4** in Windows 7 from the scrolling list, and then click **Properties**. The *Internet Protocol (TCP/IP) Properties* dialog box appears.
- 5 Write down all of the currently active network settings. You will need this information later when you restore your computer to its current network configuration.
- 6 Click **Obtain an IP address automatically**, and then configure the IP address settings with the values listed in [Table 5](#). For a sample configuration, refer to [Figure 7](#).

Table 5. Configure your computer's IP address settings

IP address	<b>Obtain an IP address automatically.</b> (Avoid 192.168.100.1, which is the default IP address assigned to the CM, and 192.168.100.2, which is the default IP address assigned to the AP.)
Subnet mask	<b>255.255.255.0</b>

**Note 1:** The administrative computer needs to be able to connect with 192.168.100.2, the IP address for the AP. The administrative computer also needs to connect with the CM, which has probably been assigned a new IP address by the network DHCP server.

**Note 2:** You can leave the *Default Gateway* and *DNS server* fields blank.

Figure 7. Sample configuration in the Internet Protocol Version 4 (TCP/IPv4) Properties dialog box

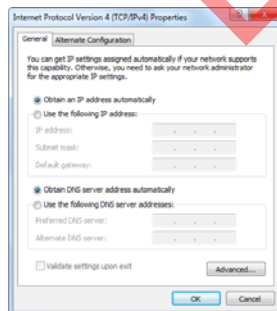

- 7 Click **OK** to save your changes and close the *TCP/IP Properties* dialog box.
- 8 Click **OK** again to close the *Local Area Connection Properties* dialog box.

Windows saves the IP address settings that you have configured.

## Operating the CM

In addition to the T504 AP command line interface (CLI) and web interface, the CM part of the T504 also has web and CLI interfaces. With these interfaces, you can operate the CM part. Refer to the following sections:

---

**NOTE** The cable modem and access point each has its own independent firmware load that is updated independently.

---

- [About the CM Command Line and Web Interfaces](#)
- [Logging Into the CM Web Interface from the T504 Ethernet Port](#)
- [Logging Into the CM Web Interface using a Dynamic IP Address](#)
- [Viewing the Software Status](#)
- [Viewing the Connection Status](#)
- [Configuring the Downstream Frequency](#)
- [Administering Cable Modem Passwords](#)
- [Viewing the SNMP Event Log](#)

### ***About the CM Command Line and Web Interfaces***

The CM command line interface is similar to the AP CLI, and is used for CM-specific operations. You can perform most CM operating tasks from the CM web interface.

### ***Logging Into the CM Web Interface from the T504 Ethernet Port***

- 1 Collect required equipment and information:
  - The IP address assigned to the CM by the CMTS DHCP server.
  - An administrative computer as configured as described in [Preparing the Administrative Computer](#).
  - One Cat5e or better Ethernet cable.
- 2 Use a 7/16" (11mm) wrench to remove the reset button and diagnostic Ethernet port screw-in plug (see [Figure 5](#)).
- 3 Connect one end of an Ethernet cable to the Ethernet port on the T504, and then connect the other end to the administrative computer's Ethernet port.
- 4 On the administrative computer, open a web browser window.

- 5 In the address or location bar, type the CM IP address, for instance:

**192.168.100.1**

--OR--

**<DHCP-assigned CM IP address>**

The cable modem web interface displays a login prompt.

- 6 Leave *User Name* blank.
- 7 In *Password*, type **ADMIN**.
- 8 Click **Log In**. The *Connection Status* page appears, indicating that you have successfully logged on to the cable modem web interface.

Continue with [Viewing the Software Status](#).

### ***Logging Into the CM Web Interface using a Dynamic IP Address***

- 1 Collect required equipment and information:
  - An administrative computer as configured as described in [Preparing the Administrative Computer](#).
  - The IP address assigned to the cable modem by the DHCP server at the CMTS.
- 2 Use a 7/16" (11mm) wrench to remove the reset button and diagnostic Ethernet port screw-in plug (see [Figure 5](#)).
- 3 Connect the administrative computer to the same subnet as the T504.
- 4 On the administrative computer, start a Web browser.
- 5 In the address bar, enter the IP address that is assigned to the cable modem. The cable modem web interface displays a login prompt.
- 6 Leave *User Name* blank.
- 7 In *Password*, type **ADMIN**.
- 8 Click **Log In**. The *Connection Status* page appears, indicating that you have successfully logged on to the cable modem web interface.

Continue with [Viewing the Software Status](#).

### ***Viewing the Software Status***

The *Software Status* page displays information about the current software version installed on the cable modem and the CM system status.

- 1 Log into to the *Status* page as described in [Logging Into the CM Web Interface from the T504 Ethernet Port](#) or [Logging Into the CM Web Interface using a Dynamic IP Address](#).
- 2 In the left sidebar, click **Software**. The *Software Status* page appears, as shown in [Figure 8](#).

Figure 8. Software Status page



There are two tables on the *Software Status* page – *Information* and *Status*. [Table 6](#) and [Table 7](#) describe the information that these tables display.

Table 6. Information (software) table

Item	Description
Standard Specification Compliant	The standard with which the device is compliant.
Hardware Version	The version of the cable modem hardware.
Software Version	The version of the cable modem software.
Cable Modem MAC Address	The MAC address of the cable modem.
Cable Modem Serial Number	The serial number of the cable modem.
CM Certificate	Indicates whether a security certificate is installed.

Table 7. Status table

Item	Description
System Up Time	Indicates the time that has elapsed since the cable modem was last rebooted.
Network Access	Indicates whether or not the cable modem is connected to the network.
Cable Modem IP Address	The IP address assigned to the CM.

## Viewing the Connection Status

The *Connection Status* page displays information about the cable modem's Hybrid Fiber Coax (HFC) and IP network connectivity, including its downstream and upstream channels and the IP address that is currently assigned to the cable modem.

- 1 Log into to the *Status* page as described in [Logging Into the CM Web Interface from the T504 Ethernet Port](#) or [Logging Into the CM Web Interface using a Dynamic IP Address](#).
- 2 Click **Connection** in the left sidebar. The CM web interface displays the *Connection Status* page.

**NOTE** The Downstream Power indicated in the Power column is accurate to +/-3dB.

Figure 9. Connection Status page - Page 1 of 2

**Status**

**Connection**

This page displays information on the status of the cable modem's HFC and IP network connectivity.

Startup Procedure	Status	Comment
Acquire Downstream Channel	825000000 Hz Locked	
Connectivity State	OK	Operational
Boot State	OK	Operational
Configuration File	OK	Jan_25_2013_Modified_Basic_config_file_ASKEY_CVC.cfg
Security	Disabled	Disabled

Channel	Lock Status	Modulation	Channel ID	Frequency	Power	SNR	Correctables	Uncorrectables
1	Locked	QAM256	1	525000000 Hz	-2.5 dBmV	43.9 dBmV	0	0
2	Locked	QAM256	2	531000000 Hz	-3.1 dBmV	41.8 dBmV	0	0
3	Locked	QAM256	3	537000000 Hz	-3.4 dBmV	41.8 dBmV	0	0
4	Locked	QAM256	4	543000000 Hz	-3.4 dBmV	41.7 dBmV	11	0
5	Locked	QAM256	5	549000000 Hz	-3.0 dBmV	41.7 dBmV	11	0
6	Locked	QAM256	6	555000000 Hz	-3.7 dBmV	42.9 dBmV	0	0
7	Locked	QAM256	7	561000000 Hz	-3.5 dBmV	43.9 dBmV	0	0
8	Locked	QAM256	8	567000000 Hz	-3.3 dBmV	44.6 dBmV	0	0

Figure 10. Connection Status page - Page 2 of 2

Channel	Lock Status	Modulation	Channel ID	Frequency	Power	SNR	Correctables	Uncorrectables
1	Locked	QAM256	1	525000000 Hz	-2.5 dBmV	43.9 dBmV	0	0
2	Locked	QAM256	2	531000000 Hz	-3.1 dBmV	41.8 dBmV	0	0
3	Locked	QAM256	3	537000000 Hz	-3.4 dBmV	41.8 dBmV	0	0
4	Locked	QAM256	4	543000000 Hz	-3.4 dBmV	41.7 dBmV	11	0
5	Locked	QAM256	5	549000000 Hz	-3.0 dBmV	41.7 dBmV	11	0
6	Locked	QAM256	6	555000000 Hz	-3.7 dBmV	42.9 dBmV	0	0
7	Locked	QAM256	7	561000000 Hz	-3.5 dBmV	43.9 dBmV	0	0
8	Locked	QAM256	8	567000000 Hz	-3.3 dBmV	44.6 dBmV	0	0

Correctables	Uncorrectables
0	0

Channel	Lock Status	US Channel Type	Channel ID	Symbol Rate	Frequency	Power
1	Locked	ATDMA	4	5120 Ksym/sec	38400000 Hz	46.3 dBmV
2	Locked	ATDMA	3	5120 Ksym/sec	12800000 Hz	46.0 dBmV
3	Locked	ATDMA	2	5120 Ksym/sec	25600000 Hz	45.7 dBmV
4	Locked	ATDMA	1	5120 Ksym/sec	32000000 Hz	47.2 dBmV

CM IP Address	Duration	Expires
20.20.20.108	D: 30 H: 01 M: 00 S: 00	Fri Sep 26 17:37:11 2014

Current System Time: Wed Aug 27 18:36:19 2014

## Configuring the Downstream Frequency

The *Configure Status* page allows you to set the downstream frequency for the cable modem. Configuring the downstream frequency enables the device to quickly obtain a direct frequency lock with the CMTS upon bootup and helps to save several minutes of scanning for an available downstream frequency from the CMTS.

- 1 Log into the *Status* page as described in [Logging Into the CM Web Interface from the T504 Ethernet Port](#) or [Logging Into the CM Web Interface using a Dynamic IP Address](#).
- 2 Click **Configure** in the left sidebar. The CM web interface displays the *Configure Status* page. See [Figure 11](#).

Figure 11. Configure Status page

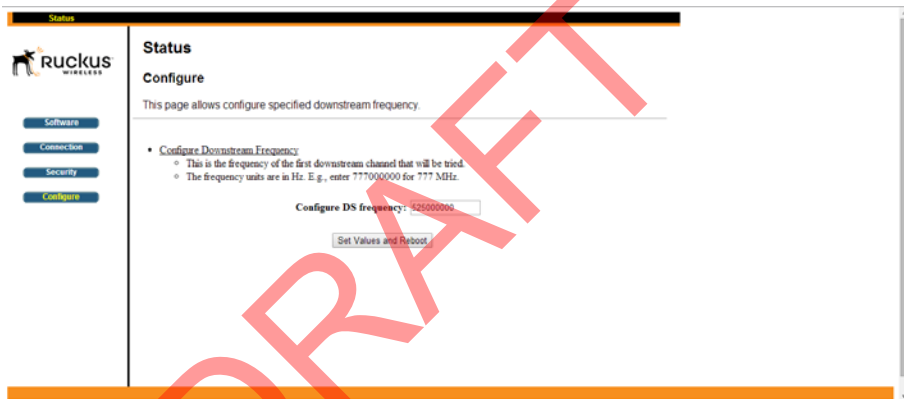

- 3 In the *Configure DS Frequency* text box, enter the downstream frequency (in Hertz) that you want the cable modem to use to connect to the CMTS when it boots up.
- 4 Click **Set Values and Reboot** to have the cable modem save your changes and reboot.

## Administering Cable Modem Passwords

The parameters on the *Security Status* page allow you to change the CM login and password, and/or restore the factory defaults.

- 1 Log into to the *Status* page as described in [Logging Into the CM Web Interface from the T504 Ethernet Port](#) or [Logging Into the CM Web Interface using a Dynamic IP Address](#).
- 2 Click **Security** in the left sidebar. The CM web interface displays the *Security Status* page.

Figure 12. Security Status page

The screenshot shows the Ruckus Wireless web interface. On the left is a sidebar with navigation links: Software, Connection, Security (highlighted), and Configure. The main content area is titled 'Status' and 'Security'. It contains a descriptive paragraph and four text input fields for password management. At the bottom, there are radio buttons for 'Restore Factory Defaults' (Yes/No) and an 'Apply' button.

- 3 Ruckus Wireless recommends that you change the login and/or password as follows:
  - a Enter a new CM user ID in *Password Change User ID*.
  - b Enter a new CM user password in *New Password*.
  - c If you are changing the password, then re-enter the new CM user password in *Re-Enter New Password*.
  - d Enter the existing (before change) CM user password in *Current User ID Password*.
- 4 Restore the factory defaults as follows:
  - Select the *Restore Factory Defaults Yes* button to reset all the CM parameters to the factory default settings after the next reboot.
  - Select the *Restore Factory Defaults No* button to prevent a reset all CM parameters to the factory defaults after the next reboot.
- 5 If you have made any changes on the *Security Status* page, then click **Apply**.
  - If you have selected the *Restore Factory Defaults Yes*, then the CM reboots and resets all CM parameters to the factory defaults.

- If you have selected the *Restore Factory Defaults* **No**, then the CM web interface saves your changes and returns you to the *Security Status* page.

### ***Viewing the SNMP Event Log***

- 1 Log into to the *Status* page as described in [Logging Into the CM Web Interface from the T504 Ethernet Port](#) or [Logging Into the CM Web Interface using a Dynamic IP Address](#).
- 2 Click **Event Log** on the menu on the left sidebar. The CM web interface displays the *SNMP Event Log Status* page.
- 3 View the SNMP events in the SNMP event log.

Figure 13. SNMP Event Log Status page

(To be determined)

- 4 If you would like to delete the SNMP events in the SNMP event log, then click **Clear Log** at the bottom of the page.

Continue with [Configuring the AP for Standalone Operation](#).



## Configuring the AP for Standalone Operation

**NOTE** If the T504 is going to be managed by an AP controller or manager, then skip this section and continue with [Verifying CM and AP Operation](#).

### *Logging Into the AP's Web Interface*

- 1 Collect required equipment and information:
  - The IP address assigned to the AP by the CMTS DHCP server.
  - An administrative computer as configured as described in [Preparing the Administrative Computer](#).
  - One Cat5e or better Ethernet cable.
  - AP MAC address (12 alphanumeric digits) from the outside of the AP case.
- 2 Verify that the AP is powered on as described in [Powering the T504 with POC](#).
- 3 Use a 7/16" (11mm) wrench to remove the reset button and diagnostic Ethernet port screw-in plug (see [Figure 5](#)).
- 4 Connect one end of the Ethernet cable to the administrative computer's Ethernet port, and then connect the other end to the T504's Ethernet port.
- 5 In an administrative computer address or location bar, type the following address:  
**https://192.168.100.2**  
--OR--  
the IP address assigned to the AP by the CMTS DHCP server
- 6 Press <Enter>. A security alert message appears.
- 7 Click **Yes** or **OK** or **Proceed anyway** (depending on the browser) to continue. The AP's login page appears.

Figure 14. The Ruckus Wireless Access Point login page



- 8 In *User name*, type **super**.
- 9 In *Password*, type **sp-admin**.
- 10 Click **Login**. The web interface displays the *Status > Device* page.
- 11 Continue with [Configuring Common Wireless Settings](#).

## Configuring Common Wireless Settings

The settings on the **Common** page are required to enable wireless devices to associate with the AP.

**NOTE** The AP has one 2.4GHz radio and one 5GHz radio. The wireless settings for each radio need to be configured separately on the Web interface. To configure the 2.4GHz radio settings, click **Configuration > Radio 2.4G**. To configure the 5GHz radio settings, click **Configuration > Radio 5G**.

- 1 On the left menu of the Web interface, click **Configuration > Radio {2.4G/5G}**. The *Common* page appears ([Figure 15](#)).

Figure 15. The Configuration > Radio 2.4 > Common Page

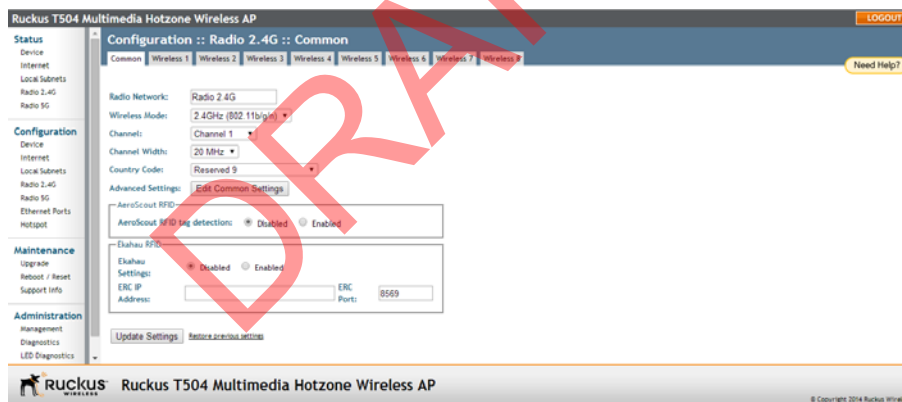

- 2 Verify that the common wireless settings are configured as listed in [Table 8](#).

Table 8. Common wireless configuration

Setting	Recommended Value
Wireless Mode	<ul style="list-style-type: none"> <li>• 2.4GHz (802.11b/g/n) for <i>Configuration &gt; Radio 2.4G &gt; Common</i>.</li> <li>• 5GHz (802.11ac/a/n) for <i>Configuration &gt; Radio 5G &gt; Common</i>.</li> </ul>

Table 8. Common wireless configuration (Continued)

Setting	Recommended Value
Channel	<i>SmartSelect.</i>
Channel Width	<i>20 MHz.</i>
Country Code	<ul style="list-style-type: none"> <li>If you purchased the AP in the United States of America, this value is fixed to <b>United States</b> at the factory and is not user configurable.</li> <li>If you purchased the AP outside the United States of America, verify that the value is set to your country or region. Selecting the correct country code ensures that the AP uses only the radio channels allowed in your country or region.</li> </ul> <p><b>NOTE:</b> <i>The two radios on the Ruckus Wireless AP are always configured with the same country code setting. If you change the country code for Radio 2.4G, for example, the same change is automatically applied to Radio 5G.</i></p>

3 If you made any changes to the *Common* page, then click **Update Settings**.

4 Repeat [Step 1](#) through [Step 3](#) for **Configuration > Radio 5G**.

Continue with [Configuring Wireless LAN Settings](#).

### **Configuring Wireless LAN Settings**

The settings on at least one **Wireless #** (Wireless LAN Number) page are required to enable wireless devices to associate with the AP. The default wireless settings are listed in [Table 9](#).

Table 9. Default wireless settings

Setting	Default Value
SSID (network name)	Wireless 1 to Wireless 8 (8 WLANs)
Encryption Method (security)	Disabled on all WLANs

1 Click one of the **Wireless #** tabs. The selected *Wireless #* page appears ([Figure 16](#)).

Figure 16. The Configuration > Radio 2.4 > Wireless 1 Page

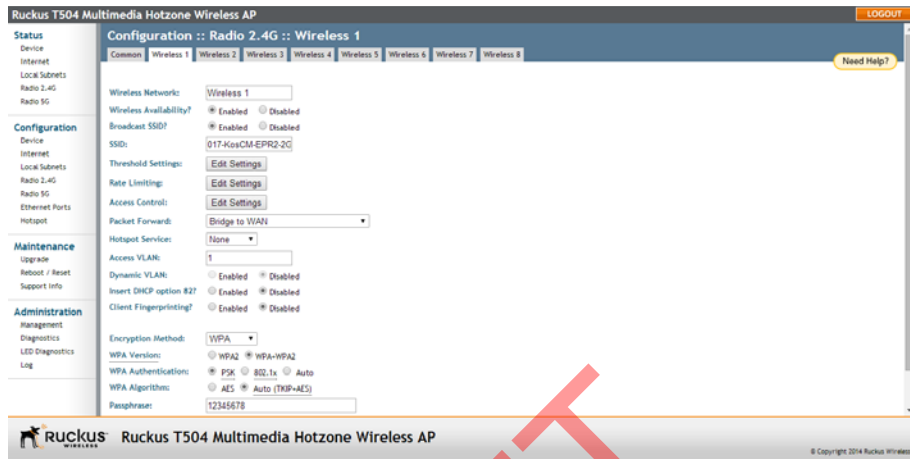

- 2 In *Wireless Availability*, click **Enabled**.
- 3 In *Broadcast SSID*, click **Enabled**.
- 4 Clear the **SSID** box, and then type a unique and descriptive name that you want to call this wireless network.

For example, you can type *Ruckus Wireless AP*. This SSID is the name that helps users identify this wireless network in their wireless network connection application.

---

**NOTE** You can also configure other wireless settings on this and other **Wireless #** pages (in addition to the settings described above), although it is not necessary for completing the AP installation.

- 5 Click **Update Settings**. You have completed configuring the basic wireless settings of the AP.
- 6 Continue with [Verifying CM and AP Operation](#).

## Verifying CM and AP Operation

The cable operator has their own CM and AP acceptance tests. Make sure you verify the T504 operation as defined in the acceptance tests before leaving the installation site.

# Operating and Troubleshooting the T504

# 4

This section lists some information that may be useful in operating and troubleshooting the T504. Topics discussed include:

- [Retrieving the CM's MAC Address](#)
- [Rebooting and Resetting the T504](#)
- [How Radio Frequency Scanning Works](#)

## Retrieving the CM's MAC Address

There are some configuration operations that require you to enter the CM's MAC address. The CM and AP MAC addresses are printed on labels on the outside of the T504, as described in [Finding the AP and CM MAC Addresses](#).

### Retrieving the CM's MAC Address

There are some configuration operations that require you to enter the CM's MAC address. The CM and AP MAC addresses are printed on labels on the outside of the T504, as described in [Finding the AP and CM MAC Addresses](#).

If you cannot find the CM's MAC address on the T504, you can retrieve it via the CMTS using the AP and CM command line interfaces:

- [Retrieving the CM's MAC Address using the CM CLI](#)
- [Retrieving the CM's MAC Address using the AP CLI](#)

### Retrieving the CM's MAC Address using the CM CLI

Use CM command line interface via the CMTS to retrieve the CM's MAC address.

- 1 Obtain the IP address assigned to the CM. You can obtain this information from the DHCP server at the CMTS.
- 2 Connect an administrative computer to the same subnet as the T504.
- 3 Start the Telnet or SSH client program on the administrative computer.
- 4 Log onto the CM using Telnet or SSH with the following logon details:
  - User name: **super**

- Password: **mso-admin**
- 5 When the command prompt appears, enter the following command:

```
cd n
cd hal
mac_address 1
```

The CLI displays the CM's MAC address.

## Retrieving the CM's MAC Address using the AP CLI

Use AP command line interface via the CMTS to retrieve the CM's MAC address.

- 1 Obtain the IP address assigned to the AP. You can obtain this information from the DHCP server at the CMTS.
- 2 Connect an administrative computer to the same subnet as the T504.
- 3 On the administrative computer, start the Telnet or SSH (secure shell) client program.
- 4 Log onto to the AP using Telnet or SSH with the following logon details:
  - User names: **super**
  - Password: **sp-admin**
- 5 When command prompt appears, enter the following command:

```
get cm supportinfo

### Basic Info ###
MAC Address: C0 xx xx xx xx xx
Software Version: V9xxxxx
WAN IP Address: 10.225.xxx.xxx
```

The command prompt displays the CM's MAC address.

## Rebooting and Resetting the T504

Refer to [Rebooting and Resetting the AP and CM](#) for instructions on rebooting and resetting the AP and CM parts of the T504.

## How Radio Frequency Scanning Works

The following steps describe how a DOCSIS-compliant T504 performs radio frequency scanning:

- 1 Looks at the last “known good channel” (repeat this every 64 channel checks).
- 2 Checks the sixteen last known frequencies (repeat this every 32 channel checks).
- 3 Scans STD standard channels (where the center of the channel is an integer spaced by 6MHz), first [from 93MHz to 999MHz - 152 channels].
- 4 Scans the harmonically related carrier (HRC) channels, which moves the channels 1.25MHz off the standard frequencies so the video carriers are all related by 6MHz [from 91.75 to 997.5MHz--152 channels].

A complete frequency scan requires approximately 469 channel checks. Since each channel takes about 0.6 seconds, a full scan is done every 281 seconds (a little under 5 minutes).

---

**NOTE** The scanning of generic DOCSIS channels is required the first time the T504 connects to an MSO. After the initial scan, the T504 is able to retrieve the local country frequency plan without a complete scan during its normal operation.

---

The following are some of the post-installation tasks that Ruckus Wireless recommends. Refer to the *Ruckus Wireless Outdoor Access Point User Guide* for more information on configuring and managing the AP.

## Changing the Administrative Password

Management access to the Web interface of the AP is controlled through administrative user name and password. As soon as you complete the AP setup, make sure you log on to the AP's Web interface and change the default administrative user name and password. This will help prevent unauthorized users from logging in to the AP's Web interface and changing the AP settings to compromise your network.

## Configuring the Security Settings

Unlike wired networks, anyone with a compatible wireless adapter can receive wireless data transmissions from your network. To prevent unauthorized users from entering your wireless network and accessing your computers and files, Ruckus Wireless strongly recommends enabling and configuring wireless security on the AP. The AP supports several types of encryption and authentication methods to help prevent unauthorized access to your wireless network.

## Configuring Advanced Settings and Features

The AP has been configured for basic operation. However, the Ruckus Wireless AP supports many advanced settings and features. Refer to the *Ruckus Wireless Outdoor Access Point User Guide* for instructions on how to configure the advanced setting and feature parameters.

## Reading Related Documentation



The latest versions of Ruckus Wireless product documentation are available for download on the Ruckus Wireless Support Web site at <http://support.ruckuswireless.com/documents>



# Appendix A: Ruckus Wireless Factory- and Customer-Supplied Parts

# A

Table 10. Factory-supplied and customer-supplied parts

Part		Ruckus Wireless P/N	T504 Kit or Customer Supplied	Notes
1m lugged earth ground wire		741-65006-001	T504 kit	
Cable power tap and connecting cable		--	Customer supplied	Antronix MGT2000-SDPE tap, or equivalent

# Appendix B: Rebooting and Resetting the T504

# B

- [Rebooting and Resetting the AP and CM](#)
- [Resetting the CM to Factory Default Settings](#)

## Rebooting and Resetting the AP and CM

---

**CAUTION!** Performing this procedure resets the AP and CM parts of the T504 to their factory default settings.

If you want to reset only the CM component to its factory default settings, then perform the procedure described in [“Resetting the CM to Factory Default Settings” on page 45](#) instead.

---

**CAUTION!** Resetting the AP and CM to factory default settings erases all the settings that you have previously configured. Also note that resetting and/or rebooting the AP and CM disrupts all wireless network communications through this device.

---

There are different ways to reboot or reset the AP and CM parts of the T504:

- [Using the Reset Button Inside the AP](#)
- [Remotely Rebooting the AP](#)

### Using the Reset Button Inside the AP

You can reset the AP and CM to their factory default settings by pressing the reset button located under the Reset button and diagnostic Ethernet port blanking cap on the T504.

- 1 Make sure that the AP is powered.
- 2 Use a 7/16” (11mm) socket to remove the Reset button and diagnostic Ethernet port cap. See [Figure 5](#) for the location of the Reset button and diagnostic Ethernet port cap.
- 3 Locate the reset button under the Reset button and diagnostic Ethernet port cap. See [Figure 17](#) for the location of the reset button inside the T504.

Figure 17. Location of the reset button

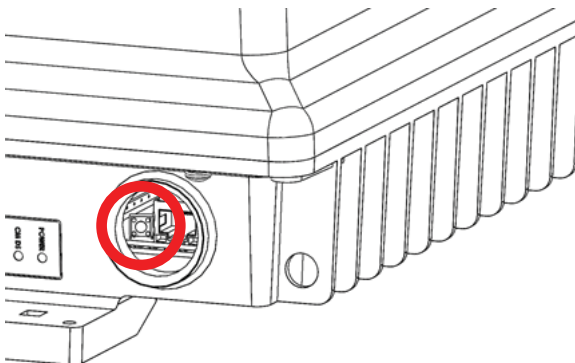

4 Using a pen or a similar pointed object, momentarily press the reset button on the reset adapter assembly to reboot the AP and CM, or hold the reset button for 10 seconds to reset the AP and CM to factory defaults.

5 Replace the Reset button and diagnostic Ethernet port cap.

You have completed resetting the AP and CM to their factory default settings and/or rebooting the AP and CM.

## Remotely Rebooting the AP

**NOTE** Before starting this procedure, you must first obtain the related MIBs from Ruckus Wireless. Contact your authorized Ruckus Wireless sales representative or Ruckus Wireless Support. Visit <http://support.ruckuswireless.com/contacts> for Ruckus Wireless Support contact information (login required).

- 1 Connect the administrative computer to the same network as the T504.
- 2 Start your MIB browser.
- 3 Load the Ruckus Wireless MIBs onto the MIB browser.
- 4 In the MIB browser, specify the IP address of the T504 AP. (You can obtain this information from the DHCP server on the network.)
- 5 Find the OID **1.3.6.1.4.1.25053.3.1.4.7.3** (ruckusZFT504ControlLED).
- 6 Set the value to **14** (powerCycleAP).

You have completed remotely rebooting the access point using SNMP.

## Resetting the CM to Factory Default Settings

---

**CAUTION!** Performing this procedure resets the CM part of the T504 to its factory default settings.

If you want to reset the AP and CM components to their factory default settings, then perform the procedure described in “[Rebooting and Resetting the AP and CM](#)” on page 43 instead.

---

You can use SNMP on either the access point or cable modem to reset the CM to factory default settings. The procedure is the same, regardless whether you perform this operation from the AP or CM.

---

**NOTE** Before starting this procedure, you must first obtain the related MIBs from Ruckus Wireless. Contact your authorized Ruckus Wireless sales representative or Ruckus Wireless Support. Visit <http://support.ruckuswireless.com/contacts> for Ruckus Wireless Support contact information (login required).

---

- 1 Connect the administrative computer to the same network as the T504.
- 2 Start your MIB browser.
- 3 Load the Ruckus Wireless MIBs onto the MIB browser.
- 4 In the MIB browser, specify the IP address of the T504 access point or cable modem. (You can obtain this information from the DHCP server on the network.)
- 5 Find the OID **1.3.6.1.4.1.25053.3.1.4.7.3** (ruckusZFT504ControlLED).
- 6 Set the value to **15** (factoryResetCM).

You have completed resetting the cable modem to factory default settings using SNMP.

# Appendix C: T504 Mounting Dimensions and Weight

# C

## Dimensions

Figure 18. T504 length--all dimensions in millimeters and [inches]

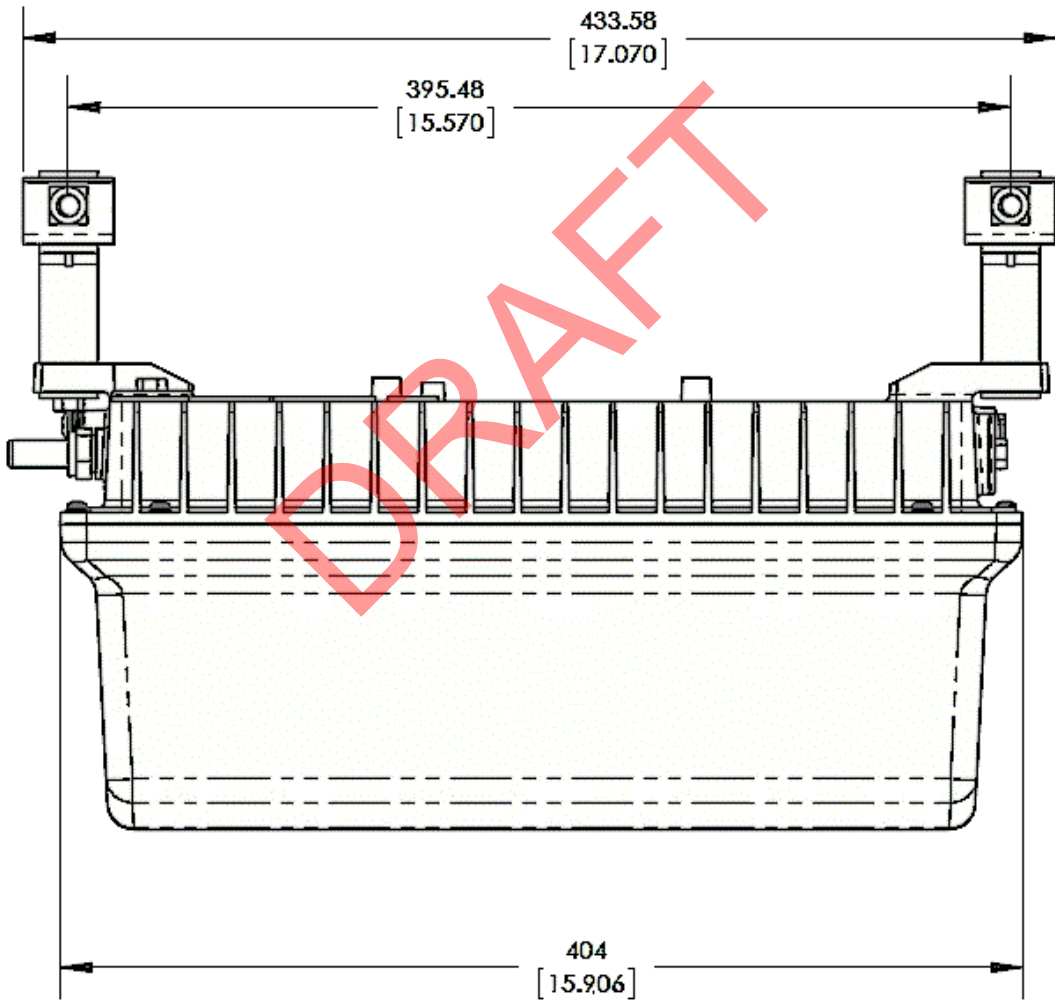
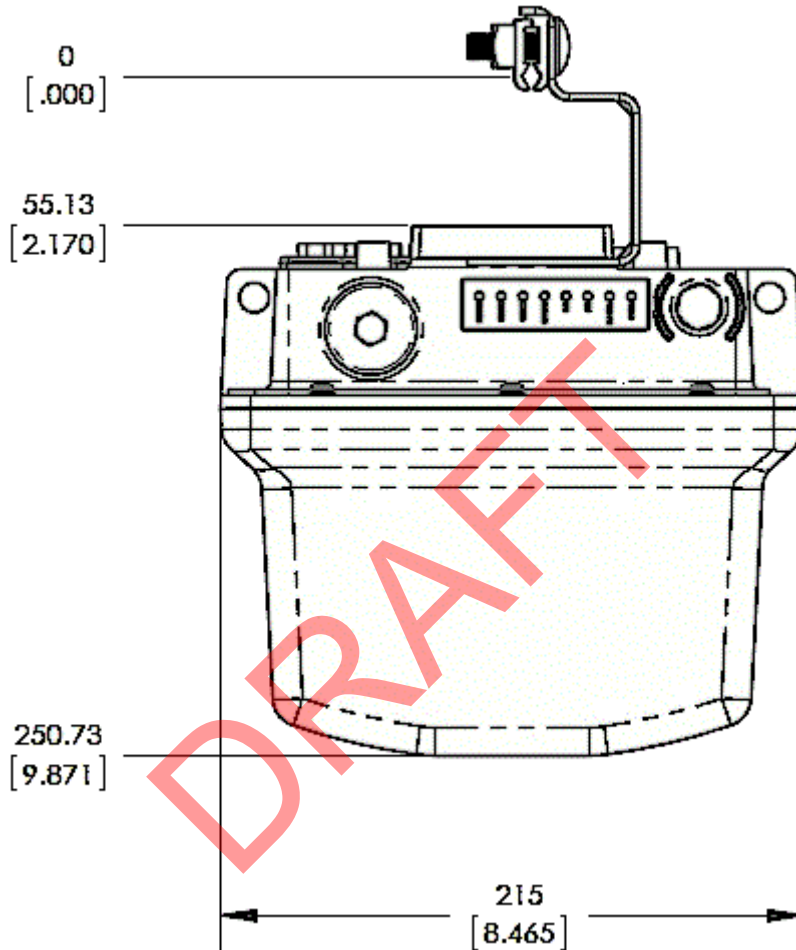

Figure 19. T504 height and width--all dimensions in millimeters and [inches]



## Weight

The T504 weighs 9.5 pounds. For other specifications, refer to the Ruckus Wireless data sheet.

DRAFT

DRAFT



Copyright © 2006-2014. Ruckus Wireless, Inc.  
350 West Java Dr. Sunnyvale, CA 94089. USA  
[www.ruckuswireless.com](http://www.ruckuswireless.com)