



T811-CM Access Point

Installation Guide

Applies to 901-T811-US01

Copyright Notice and Proprietary Information

Copyright 2017. Ruckus Wireless, Inc. All rights reserved.

No part of this documentation may be used, reproduced, transmitted, or translated, in any form or by any means, electronic, mechanical, manual, optical, or otherwise, without prior written permission of Ruckus Wireless, Inc. ("Ruckus"), or as expressly provided by under license from Ruckus.

Destination Control Statement

Technical data contained in this publication may be subject to the export control laws of the United States of America. Disclosure to nationals of other countries contrary to United States law is prohibited. It is the reader's responsibility to determine the applicable regulations and to comply with them.

Disclaimer

THIS DOCUMENTATION AND ALL INFORMATION CONTAINED HEREIN ("MATERIAL") IS PROVIDED FOR GENERAL INFORMATION PURPOSES ONLY. RUCKUS AND ITS LICENSORS MAKE NO WARRANTY OF ANY KIND, EXPRESS OR IMPLIED, WITH REGARD TO THE MATERIAL, INCLUDING, BUT NOT LIMITED TO, THE IMPLIED WARRANTIES OF MERCHANTABILITY, NON-INFRINGEMENT AND FITNESS FOR A PARTICULAR PURPOSE, OR THAT THE MATERIAL IS ERROR-FREE, ACCURATE OR RELIABLE. RUCKUS RESERVES THE RIGHT TO MAKE CHANGES OR UPDATES TO THE MATERIAL AT ANY TIME.

Limitation of Liability

IN NO EVENT SHALL RUCKUS BE LIABLE FOR ANY DIRECT, INDIRECT, INCIDENTAL, SPECIAL OR CONSEQUENTIAL DAMAGES, OR DAMAGES FOR LOSS OF PROFITS, REVENUE, DATA OR USE, INCURRED BY YOU OR ANY THIRD PARTY, WHETHER IN AN ACTION IN CONTRACT OR TORT, ARISING FROM YOUR ACCESS TO, OR USE OF, THE MATERIAL.

Trademarks

Ruckus Wireless, Ruckus, Bark Logo, and ZoneFlex are trademarks of Ruckus Wireless, Inc. in the United States and other countries. All other product or company names may be trademarks of their respective owners.

Contents

1	About This Installation Guide	
	Using this Installation Guide	8
	Terms Used in This Guide.....	10
	Related Documentation	10
	Documentation Feedback.....	10
2	Planning the T811-CM Installation	
	T811-CM Omni Antenna Coverage.....	12
	Powering Options.....	13
	Performing a Site Survey.....	13
3	Installing the T811-CM	
	Safety Information.....	16
	Unpacking the T811-CM.....	17
	Package Contents	17
	AP and CM MAC Addresses, Connectors and Ground Point.....	18
	LEDs and Reset Button/Diagnostic Ethernet Port.....	19
	LED Startup Sequence	20
	Deploying the T811-CM.....	21
	Mounting the T811-CM.....	21
	Earth Grounding the T811-CM.....	22
	Installing the Cable Power Tap.....	23
	Powering the T811-CM with POC.....	24
	Checking the T811-CM Signal Level with an RF Power Meter (Optional)	25
	Configuring the T811-CM for the First Time (Optional)	26
	Re-Installing an Access Plug or Hardline Adapter.....	35
	Verifying CM and AP Operation.....	35
4	Operating and Troubleshooting the T811-CM	
	Retrieving the CM's MAC Address.....	37
	Retrieving the CM's MAC Address	37
	Rebooting and Resetting the T811-CM.....	38
	How Radio Frequency Scanning Works	39
5	What to Do Next	
	Changing the Administrative Password	41
	Configuring the Security Settings	41
	Configuring Advanced Settings and Features	41
	Reading Related Documentation.....	41
	Appendix A: Ruckus Wireless Factory- and Customer-Supplied Parts	
	Appendix B: T811-CM Mounting Dimensions and Weight	
	Dimensions	45
	Weight	47

Appendix C: Replacing the F Connector Adapter

Appendix D: Rebooting and Resetting the T811-CM

Rebooting and Resetting the AP and CM.....	51
Using the Reset Button Inside the AP.....	51
Remotely Rebooting and Factory Resetting the AP.....	52
Rebooting and Factory-Resetting the CM	53

About This Installation Guide

1

This *Installation Guide* provides information on how to set up the Ruckus Wireless T811-CM (model 901-T811-CM-US31) strand mount access point (AP) with integrated cable modem (CM) on your network. Topics covered in this guide include basic configuration, operation and mounting. The rest of this document refers to the strand mount access point with integrated cable modem as the **T811-CM**.

This guide is intended for use by those installing and configuring network equipment. Consequently, it assumes a basic working knowledge of local area networking, cable modem configuration, wireless networking, and wireless devices.

Figure 1. Typical T811-CM mounted on a cable strand

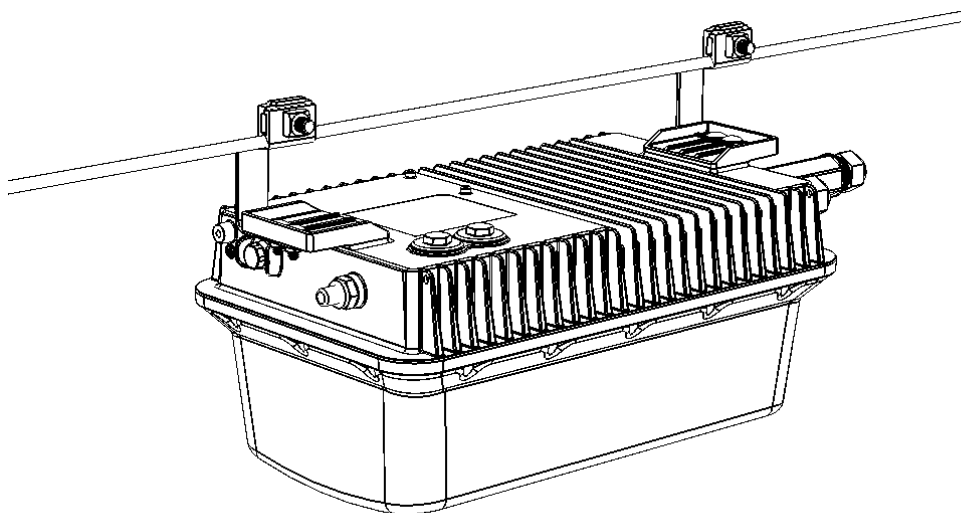

Using this Installation Guide

The T811-CM installation is completed with four main steps. Each step includes some substeps. [Figure 2](#) shows the main steps, and [Table 1](#) includes the substeps.

Figure 2. Adding a T811-CM to an existing Ruckus Wireless network flowchart

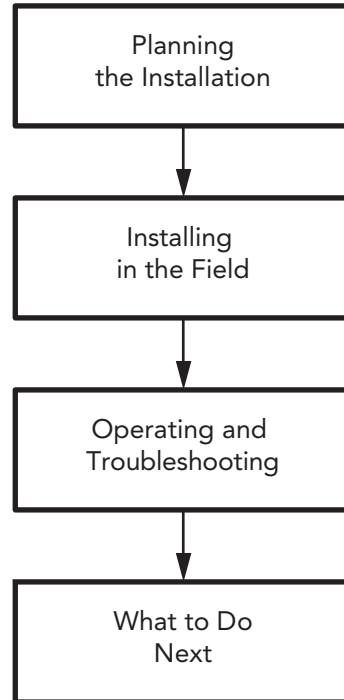

Table 1. Adding a T811-CM to an Existing Ruckus Wireless network

Section	Heading
2	Planning the T811-CM Installation <ul style="list-style-type: none">• T811-CM Omni Antenna Coverage• Powering Options• Performing a Site Survey
3	Installing the T811-CM <ul style="list-style-type: none">• Safety Information• Unpacking the T811-CM• Finding the AP and CM MAC Addresses• Connectors and Ground Point• LEDs and Reset Button/Diagnostic Ethernet Port• Dimensions• Deploying the T811-CM• Verifying CM and AP Operation
4	Operating and Troubleshooting the T811-CM <ul style="list-style-type: none">• Retrieving the CM's MAC Address• Rebooting and Resetting the T811-CM• How Radio Frequency Scanning Works
5	What to Do Next <ul style="list-style-type: none">• Changing the Administrative Password• Configuring the Security Settings• Configuring Advanced Settings and Features• Reading Related Documentation

Terms Used in This Guide

Before continuing, Ruckus Wireless recommends that you become familiar with the following terms:

- *T811-CM*: T811-CM strand mount AP with integrated CM, which includes the AP and CM and the cable strand interface.
- *AP*: The Wi-Fi Access Point part of the T811-CM.
- *CM*: The Cable Modem part of the T811-CM.
- *CMTS*: Cable modem termination system high speed data services equipment.
- *HFC*: Hybrid fiber coax broadband network.
- *MSO*: Multiple system operator.

Related Documentation

In addition to this guide, each T811-CM documentation set includes the following:

- *User Guide*: Provides detailed information on how to configure the functions of the unit. The User Guide is available for download on the Ruckus Wireless Support Web site at <http://support.ruckuswireless.com/documents>
- *Release Notes*: Provides late-breaking information about the current software release, including new features, enhancements, and known issues. If the information in the Release Notes differs from the information in this guide, follow the instructions in the Release Notes.

Documentation Feedback

Ruckus Wireless is interested in improving its documentation and welcomes your comments and suggestions. You can email your comments to Ruckus Wireless at docs@ruckuswireless.com

When contacting us, please include the following information:

- Document title
- Document part number (on the cover page)
- Page number (if appropriate)

For example:

- *T811-CM AP Installation Guide*
- Part number: 800-71436-001 Rev A
- Page 11

Planning the T811-CM Installation

2

Before installing the T811-CM, plan the T811-CM installation. In this chapter:

- [T811-CM Omni Antenna Coverage](#)
- [Powering Options](#)
- [Performing a Site Survey](#)

T811-CM Omni Antenna Coverage

The T811-CM includes internal 5GHz and 2.4GHz omnidirectional antennas, and is equipped with a DOCSIS 3.1 cable modem.

The T811-CMs are best deployed where internal-antenna lateral beamforming can provide the greatest reach and throughput to a wide coverage area, and provide the greatest distance between APs in a connecting device. See [Figure 3](#) for internal-antenna coverage patterns, and see [Figure 4](#) for a typical mesh coverage pattern between a T811-CM root AP and a 7782 non-root AP.

Figure 3. Omni 5GHz and 2.4GHz coverage

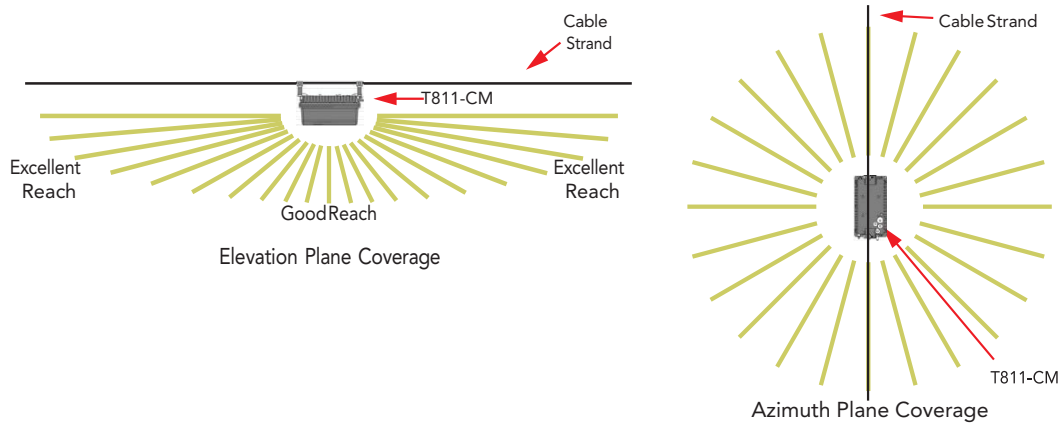
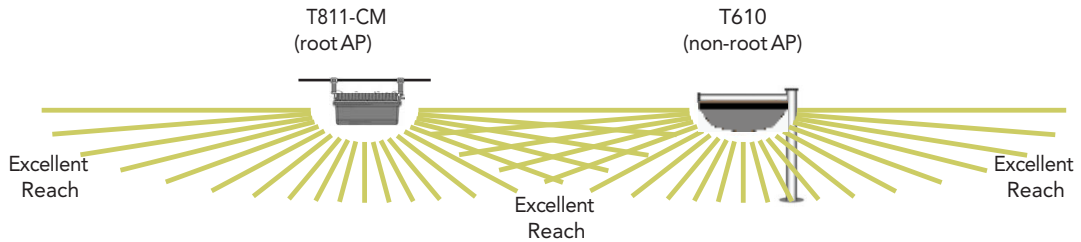

Figure 4. Typical mesh elevation plane coverage, side view



Powering Options

The T811-CM supports AC power over cable (POC). 60 to 90 VAC POC is used when the T811-CM is powered via an F-type coaxial cable connected to the HFC cable plant.

Performing a Site Survey

Perform a site survey to determine the optimal T811-CM placement for maximum range, coverage, and network performance. Ruckus Wireless Support can supply site survey best practices information.

The location and orientation that you choose for the T811-CM play a critical role in the performance of your wireless network. In general, Ruckus Wireless recommends installing the T811-CM away from obstructions and sources of interference and ensuring that the AP's best coverage zone is pointing in the general direction of its wireless clients or associated bridge units as described in [T811-CM Omni Antenna Coverage](#).

When performing a site survey, consider the following factors:

- *Data rates:* Range is generally inversely proportional to data rates. The maximum radio range is achieved at the lowest workable data rate. Higher data rates are generally achieved at closer distances.
- *Antenna type and placement:* Proper antenna configuration is a critical factor in maximizing radio range. As a general rule, radio range is increased by mounting the radio higher off of the ground with the AP oriented so that the dome is tilted down. (For recommended orientation examples, refer to [T811-CM Omni Antenna Coverage](#).)
- *Physical environment:* Clear or open areas provide better radio range than crowded or filled areas. The less cluttered the operating environment, the greater the wireless range.
- *Obstructions, building materials, and sources of interference:* Physical obstructions, such as concrete pillars, steel beams, buildings and trees, can block or hinder wireless communication. Avoid installing the T811-CM in an environment where there is an obstruction between sending and receiving devices. A number of machines and electronic devices that emit radio waves – cranes, wireless phones, microwave ovens, and satellite dishes – interfere with and block wireless signals. Building materials used in construction also influence radio signal penetration. For example, drywall construction permits greater range than concrete blocks.
- *Mounting:* The T811-CM is designed to clamp onto a 1/4" to 3/8" (6.35mm to 10mm) support wire. The hangers allow a 2" bundle of cables between the support wire and the T811-CM.
- *Power and backhaul connections:* The T811-CM needs a backhaul connection to the CMTS and it needs to be close enough to an AC power injector on the CATV cable to assure that it is able to pull 60-90VAC. If not, then another power injector must be installed closer to the T811-CM. If SFP backhaul is used, POC will still be used for delivering power over the cable, even if the data is transmitted over the SFP fiber cable.

When you are finished planning the installation, continue with [Installing the T811-CM](#).

Positioning the GPS Antenna

The T811-CM AP includes an internal GPS antenna. If the AP is to be used with the optional GPS feature enabled, then the GPS antenna must be mounted outdoors and have as clear a view of the sky as possible (as close as possible to 360 degrees, and with no obstructing trees or buildings). The GPS antenna must not be installed where it can be covered with

snow buildup to avoid attenuating the GPS signal. These requirements must be met to ensure that the GPS module can obtain lock and provide accurate GPS time and position. If the GPS antenna has less than a clear 360-degree view of the sky, then the GPS module may experience degraded performance.

Fig. 5 T811-CM mounting GPS considerations

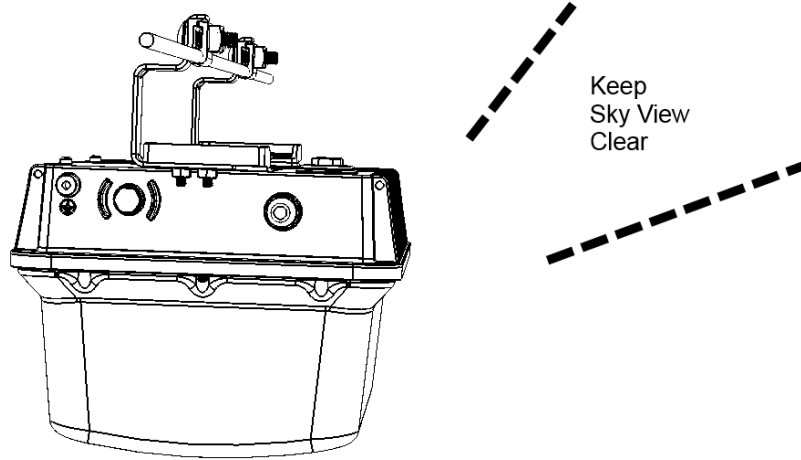

Installing the T811-CM

3

Before installing the T811-CM, Ruckus Wireless recommends that you first complete the procedures described in [Planning the T811-CM Installation](#).

In this chapter:

- [Safety Information](#)
- [Unpacking the T811-CM](#)
- [AP and CM MAC Addresses, Connectors and Ground Point](#)
- [LEDs and Reset Button/Diagnostic Ethernet Port](#)
- [Dimensions](#)
- [Deploying the T811-CM](#)
- [Verifying CM and AP Operation](#)

Safety Information

WARNING! Only trained and qualified installers should be allowed to install, replace, or service this equipment.

The professional installer is responsible for the proper installation and configuration of this AP. The AP installation must comply with local regulatory requirements, especially with those regulating operation near military and/or weather radar systems.

WARNING! Installation of this equipment must comply with local and national electrical codes.

WARNING! Ruckus Wireless strongly recommends that you wear eye protection before mounting the AP.

CAUTION! Make sure that you form a 80mm - 130mm (3"-5") drip loop in any cable that is attached to the AP or other equipment. This will prevent water from running along the cable and entering the AP or other equipment.

CAUTION! Be sure that grounding is available and that it meets local and national electrical codes. For additional lightning protection, use lightning rods and lightning arrestors.

CAUTION! Make sure that proper lightning surge protection precautions are taken according to local electrical code.

Unpacking the T811-CM

- 1 Open the T811-CM package, and then carefully remove the contents.
- 2 Return all packing materials to the shipping box, and put the box away in a dry location.
- 3 Verify that all items listed in [Package Contents](#) are included in the package. Check each item for damage. If any item is damaged or missing, notify your authorized Ruckus Wireless sales representative.

NOTE [Appendix A: Ruckus Wireless Factory- and Customer-Supplied Parts](#) includes illustrations and descriptions of these and other factory-orderable and customer-supplied parts.

Package Contents

A Ruckus Wireless T811-CM package contains the items listed below:

- Ruckus Wireless T811-CM unit with cable strand hangers, includes one 12mm long stainless steel M6x1 earth ground panhead screw with split lock and flat washers
- A one-meter green/yellow earth ground wire with ring terminal
- Safety cable kit
- Cable gland/cable gland extender
- Service Level Agreement/Limited Warranty Statement
- Regulatory Statement
- Declaration of Conformity, if required
- This Installation Guide

AP and CM MAC Addresses, Connectors and Ground Point

The T811-CM MAC address label lists separate addresses for the internal AP and the cable modem (CM). The MAC address label (1 in Figure 5) is mounted on the end of the T811-CM with the F type connector and the ground screw (2 and 3 in Figure 5). Table 2 describes the label, connector and the ground point screw.

Figure 5. T811-CM MAC address label, F type connector and ground point

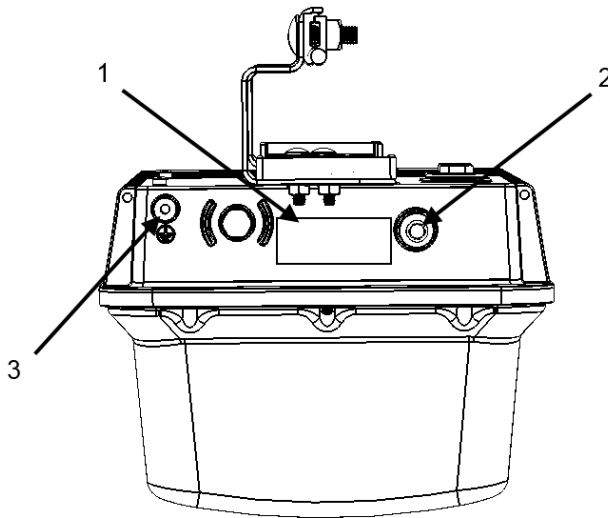

Table 2. Connectors and ground point on the T811-CM

No.	Label	Description
1	MAC Address Label location	Labels include separate addresses for the internal AP and CM.
2	Coaxial Cable Connector	F type, connects to the CMTS at the headend using a tap on the plant, and provides AC POC to the T811-CM. For more information, refer to Powering Options .
3	Optional External Earth Ground Point	The T811-CM is normally earth-grounded by the cable strand. However, if the cable strand is not earth grounded, then connect an external earth ground to the T811-CM using this screw-and-washer set.

LEDs and Reset Button/Diagnostic Ethernet Port

Use the eight LEDs to check the status of the access point and cable modem. [Figure 6](#) shows the LEDs on the T811-CM, and [Table 3](#) describes the LEDs and the reset button/diagnostic Ethernet port.

Figure 6. T811-CM LEDs and reset button/diagnostic Ethernet port when the dome is pointing downwards

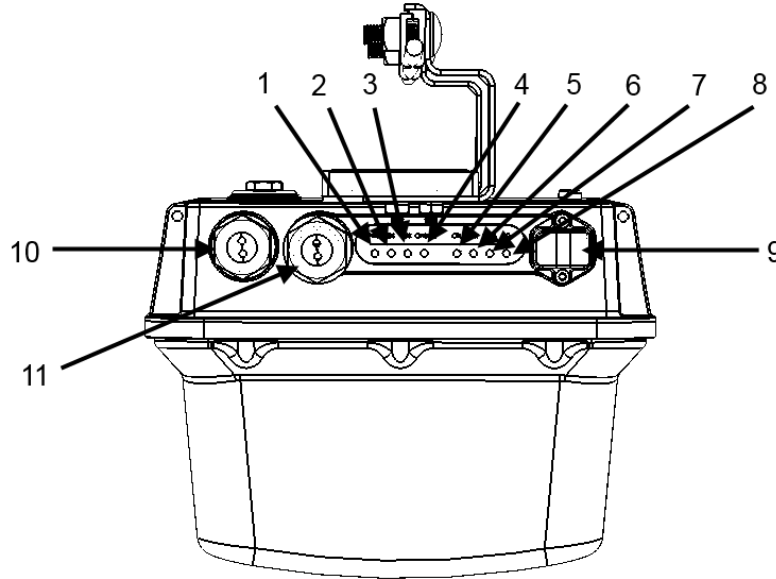

Table 3. LEDs and reset button/diagnostic Ethernet port

No.	Label	Description
1	POWER	<ul style="list-style-type: none"> • <i>Off</i>: AP off. • <i>Blinking red</i>: Boot up in process. • <i>Solid Green</i>: AP on.
2	CM DS	<ul style="list-style-type: none"> • Blinks when searching for downstream (DS), then solid when DS is locked. Also blinks during CM boot when power is applied.
3	CM US	<ul style="list-style-type: none"> • Off when upstream (US) is searching, and then blinks as upstream power is increased/ranged and then solid when upstream ranging is complete. Also blinks during CM boot when power is applied.
4	ONLINE	<ul style="list-style-type: none"> • Off until CM DS and CM US are solid ON, then blinks as the CM obtains an IP address and a configuration file, and then comes online and LED is solid. Also blinks during CM boot when power is applied.
5	CTL	<ul style="list-style-type: none"> • On when the Access Point is being managed by a Ruckus Wireless controller.
6	AIR	<ul style="list-style-type: none"> • <i>Off</i>: The Access Point is operating in standalone mode, or the uplink is through its wired Ethernet interface. The wireless uplink interface is down. • <i>Solid green</i>: The AP is operating as a Mesh AP (MAP), and the wireless signal to its uplink AP is good.
7	2.4 GHz	<ul style="list-style-type: none"> • <i>Off</i>: The 2.4GHz WLAN service is down. • <i>Solid green</i>: The 2.4GHz WLAN service is up and at least one client is associated. • <i>Solid amber</i>: The 2.4GHz WLAN service is up. No clients are associated.

8	5 GHz	<ul style="list-style-type: none"> • <i>Off</i>: The 5GHz WLAN service is down. • <i>Solid amber</i>: The 5GHz WLAN service is up, but no clients are associated/connected. • <i>Solid green</i>: The 5GHz WLAN service is up and at least one client is associated.
9	USB Port	<ul style="list-style-type: none"> • USB port for IoT devices, such as BLE Smart Beacon, Gimbal, Zigbee/Thread dongle, etc. • Max Dimensions: 6cm x 2cm x 1.1 cm • Max Weight: 8 ounces • Max Power: 450 mW (SiLabs EM3578 max current draw at +20 dBm is 80mA over a 3.3V rail) • Interface: USB 2.0 • Connector: USB Type-A plug
10	Eth Port / Reset Button	<ul style="list-style-type: none"> • 1 x 10/100/1000 PoE Out port (802.3at) • Supports PoE PSE (802.3at) 30W • Reset Button: Depress quickly to reboot both the AP and the CM (4 sec or less). Press and hold for 5-10 seconds to perform a full reset to factory default settings.
11	SFP Fiber interface	<ul style="list-style-type: none"> • Supports hot swappable SFP module • Supports the following SFP modules: <ul style="list-style-type: none"> • Finisar GPON FTGN2117P2TUN • Finisar EPON FTEN2217P1CUN-BC • Finisar 1000BaseLX FLTF1318P3BLT • Xavi XO-3901 GPON ONT (***) need to verify)
		<ul style="list-style-type: none"> • (***) add SFP LED behavior)

LED Startup Sequence (CM Backhaul)

The startup sequence from factory default state to operational state is as follows:

1. At power on, the **Power** LED is red, then blinking green during bootup.
2. **CM DS** LED blinks while finding CM downstream link, then solid once complete.
3. **CM US** LED blinks while finding CM upstream link, then solid once complete.
4. **Online** LED blinks while getting new config from CMTS, and solid once configuration is complete.
5. **Power** LED is solid green once an IP address is received.
6. Once the AP is approved on the controller, the **DIR** LED starts blinking, indicating firmware downloading.

Note: If the AP was preconfigured at the factory and does not need a firmware upgrade, this step is skipped.

7. Once firmware upgrade is complete, the AP reboots and the **Power** LED turns red, then blinking green, then solid green once reboot is complete.
8. **AIR, 2.4 GHz** and **5 GHz** LEDs are the same as other Ruckus APs: Amber when SSID is up, green when clients connected to the radio. The **AIR** LED indicates Mesh AP upstream connectivity; therefore it will not generally be lit on a cable modem AP, whose backhaul should be the cable modem rather than a mesh link.

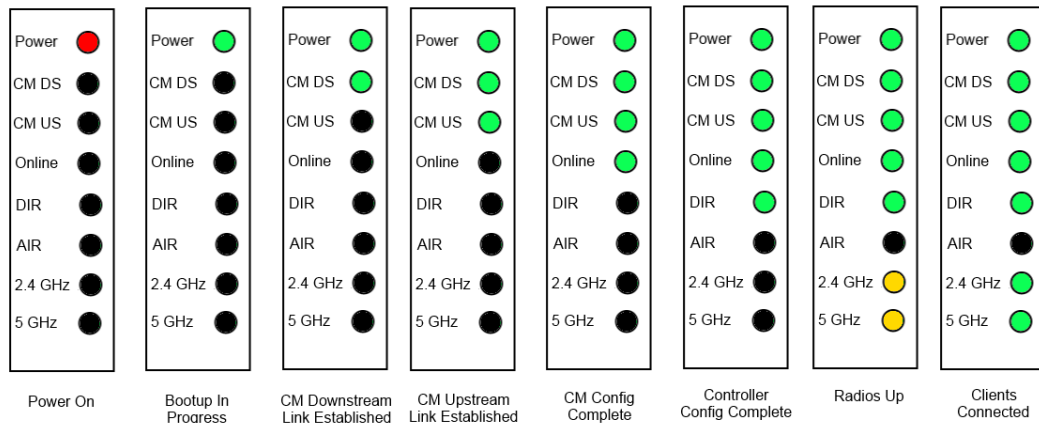

LED Startup Sequence (SFP Backhaul)

(***XXX***)

Deploying the T811-CM

In this section, you will mount the T811-CM in its final mounting location. Perform the following:

- [Mounting the T811-CM](#)
- [Earth Grounding the T811-CM](#)
- [Installing the Cable Power Tap](#)
- [Powering the T811-CM with POC](#)
- [Checking the T811-CM Signal Level with an RF Power Meter \(Optional\)](#)
- [Configuring the T811-CM for the First Time \(Optional\)](#)

Mounting the T811-CM

To mount the T811-CM assembly on a cable strand, you need to secure the cable clamps that are attached to the strand interface to the cable strand.

- 1 Slightly loosen the nuts that fasten the two cable clamps to the strand interface, enough for the strand support cable to fit into the cable clamps.
- 2 Place the cable clamps on the strand support cable.
- 3 Tighten the two cable clamp nuts to 22 to 27N.m (16 to 20 ft-lbs) to secure the mounting.

You have mounted the T811-CM. Continue with [Earth Grounding the T811-CM](#).

Earth Grounding the T811-CM

The cable strand is usually earth-grounded, and mounting the T811-CM on the cable strand earth grounds the T811-CM chassis as well; if this is the case, skip this procedure and continue with [Installing the Cable Power Tap](#).

CAUTION! Be sure that earth grounding is available and that it meets local and national electrical codes. For additional lightning protection, use lightning rods and lightning arrestors.

If the cable strand is not earth-grounded, then continue with the following:

- 1 The color coding of ground wires varies by region. Before completing this step, check your local wiring standards for guidance.
 - 2 Using the factory-supplied ground screw and washers, use the factory-supplied earth ground wire with ring terminal to connect a good earth ground to the T811-CM using the chassis ground screw shown in [Figure 5](#).
-

CAUTION! The T811-CM includes one 12mm stainless steel M6x1 earth ground screw with split lock and flat washers. Make sure that any replacement screw is no longer than 12mm. If a screw is longer than 12mm, it can damage the T811-CM chassis.

You have earth-grounded the T811-CM. Continue with [Installing the Cable Power Tap](#).

Installing the Cable Power Tap

The CATV coaxial cable used in the field deployment must have 60 to 90 VAC power multiplexed with the RF signal on the coaxial cable, since the T811-CM Connector B is used for both electrical power and the RF signal.

Ruckus Wireless recommends installing a cable power tap (Antronix MGT2000-SDPE tap, or equivalent) close to the T811-CM. Refer to the manufacturer's instructions to mount the cable power tap on the coaxial cable. [Figure 7](#) shows a typical cable power tap and connection to the CM using an RG6 quad shield cable. [Table 4](#) describes the elements in [Figure 7](#).

NOTE If the F connector on the T811-CM is damaged, then refer to [Appendix C: Replacing the F Connector Adapter](#).

- 1 Use a customer-supplied cable, connect any port on the cable power tap to the F connector on the T811-CM.
- 2 Using a wrench, tighten the cable F connectors to 3.4N.m or 30in-lbs.

Figure 7. Cable Power Tap Connection to the T811-CM Cable Modem

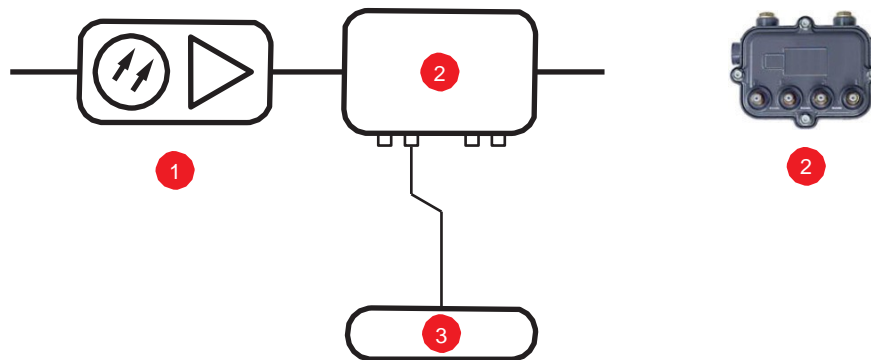

Table 4. Typical cable power tap connections

No.	Description
1	<ul style="list-style-type: none"> • Line amplifier/high output node.
2	<ul style="list-style-type: none"> • Typical cable power tap. <p>Note: Use any connector on the power tap.</p>
3	<ul style="list-style-type: none"> • Cable modem.

Continue with [Powering the T811-CM with POC](#).

Powering the T811-CM with POC

60 to 90 VAC POC is used when the T811-CM is mounted on a cable strand and powered via an F-type coaxial cable connected to the HFC cable plant.

- 1 Remove the power jumper from the power tap to remove AC power out of the power tap.
- 2 Insert the F-type coaxial cable that is connected to the HFC cable plant to the F-type connector on the T811-CM. Power is supplied through a power passing tap on the CATV coax. The tap is connected to F-type connector on the T811-CM as shown in [Figure 5](#).
- 3 Finger tighten the coaxial cable connector and then tighten to 3.4N.m (30in-lbs).
- 4 Plug the power jumper back into the power tap to restore AC power out of the power tap.
- 5 When the T811-CM receives power, its LEDs flash on and off as it goes through a power-on self test and then receives its AP and CM configurations from the cable operator.

NOTE Normally, the T811-CM receives its AP and CM configurations from the cable operator. This means that the installer does not need to manually configure either the AP or the CM part of the T811-CM.

- 6 Wait until the T811-CM **PWR**, **CM DS**, **CM US**, and **ONLINE** LEDs stop flashing and then remain on.

You have verified that the T811-CM is powered. Continue with [Checking the T811-CM Signal Level with an RF Power Meter \(Optional\)](#).

Checking the T811-CM Signal Level with an RF Power Meter (Optional)

The CMAP cable modem is just like a standard DOCSIS 3.1 modem installed at home. Connect an RF power meter to the cable from the cable power tap to measure the downstream power coming from the cable.

The power level should be between +15dBmV and -15dBmV.

Configuring the T811-CM for the First Time (Optional)

NOTE The T811-CM normally receives its latest AP and CM firmware downloads and initial configurations from the cable modem termination system high speed data services (CMTS) equipment when it powers up; if this is the case, then skip this section and continue with [Re-Installing an Access Plug or Hardline Adapter](#).

(*****XXX**** add SFP use case)

If the T811-CM AP and CM do not receive their latest firmware downloads and initial configurations from the CMTS equipment when the T811-CM powers up, then continue with this procedure:

- [Preparing the Administrative Computer](#)
- [Operating the CM](#)

Preparing the Administrative Computer

Use an administrative computer to configure basic operational parameters for the T811-CM access point and cable modem parts.

NOTE The following procedure is applicable if the administrative computer is running Windows 7. Procedures for other operating systems are similar.

- 1 Collect required equipment and information:
 - An administrative computer (notebook computer) with an Ethernet port and a wireless card installed.
 - A Web browser such as Google Chrome, Mozilla Firefox (or later) or Microsoft Internet Explorer installed on the administrative computer.
 - A Telnet or SSH (secure shell) client program installed on the administrative computer.
 - 2 On your Windows computer, open the **Network Connections** (or **Network and Dial-up Connections**) control panel according to how the *Start* menu is set up:
 - On Windows 7, click **Start > Control Panel > Network and Sharing Center > Change Adapter Settings**.
 - 3 When the *Network Connections* window appears, right-click the icon for *Local Area Connection*, and then click **Properties**.
-

NOTE Make sure that you configure the *Local Area Connection* properties, not the *Wireless Network Connection* properties.

- 4 When the *Local Area Connection Properties* dialog box appears, select **Internet Protocol (TCP/IP)** or **TCP/IPv4** in Windows 7 from the scrolling list, and then click **Properties**. The *Internet Protocol (TCP/IP) Properties* dialog box appears.
- 5 Write down all of the currently active network settings. You will need this information later when you restore your computer to its current network configuration.

- 6 Select **IP address automatically**, and then configure the IP address settings with the values listed in [Table 6](#). For a sample configuration, refer to [Figure 8](#).

Table 6. Configure your computer's IP address settings

IP address	192.168.100.22. (Avoid 192.168.100.1, which is the default IP address assigned to the CM, and 192.168.100.2, which is the default IP address assigned to the AP.)
Subnet mask	255.255.255.0

Note 1: The administrative computer needs to be able to connect with 192.168.100.2, the IP address for the AP. The administrative computer also needs to connect with the CM, which has probably been assigned a new IP address by the network DHCP server.

Note 2: You can leave the *Default Gateway* and *DNS server* fields blank.

Figure 8. Sample configuration in the Internet Protocol Version 4 (TCP/IPv4) Properties dialog



- 7 Click **OK** to save your changes and close the *TCP/IP Properties* dialog.

- 8 Click **OK** again to close the *Local Area Connection Properties* dialog.

Continue with [Operating the CM](#).

Operating the CM

In addition to the T811-CM AP command line interface (CLI) and Web interface, the CM part of the T811-CM also has Web and CLI interfaces. With these interfaces, you can operate the CM part. Refer to the following sections:

NOTE The cable modem and access point each has its own independent firmware load that is updated independently.

- [Logging Into the CM Web Interface](#)
- [Viewing the Software Status](#)
- [Viewing the Connection Status](#)
- [Configuring the Downstream Frequency](#)
- [Administering Cable Modem Passwords](#)

Logging Into the CM Web Interface

The CM command line interface is similar to the AP CLI, and is used for CM-specific operations. You can perform most CM operating tasks from the CM Web interface. Log into the CM Web interface as follows:

- 1 Collect required equipment and information:

- The IP address assigned to the CM by the CMTS DHCP server.
 - An administrative computer as configured as described in [Preparing the Administrative Computer](#).
 - One Cat5e or better Ethernet cable.
 - 7/16" (11mm) wrench.
- 2 Use a 7/16" (11mm) wrench to remove the reset button and diagnostic Ethernet port screw-in access plug (see [Figure 6](#)).
 - 3 Connect one end of an Ethernet cable to the Ethernet port on the T811-CM, and then connect the other end to the administrative computer's Ethernet port.
 - 4 On the administrative computer, open a Web browser window.
 - 5 In the address or location bar, enter the IP address that is assigned to the cable modem, for instance:

192.168.100.1

--OR--

<DHCP-assigned CM IP address>

The cable modem Web interface displays a login prompt.

- 6 Leave *User Name* blank.
- 7 In *Password*, type **ADMIN**.
- 8 Click **Log In**. The *Connection Status* page appears, indicating that you have successfully logged on to the cable modem Web interface.

Continue with [Viewing the Software Status](#).

Viewing the Software Status

The *Software Status* page displays information about the current software version installed on the cable modem and the CM system status.

- 1 Log into to the *Status* page as described in [Logging Into the CM Web Interface](#).
- 2 In the left sidebar, click **Software**. The *Software Status* page appears, as shown in [Figure 9](#).

Figure 9. Software Status page

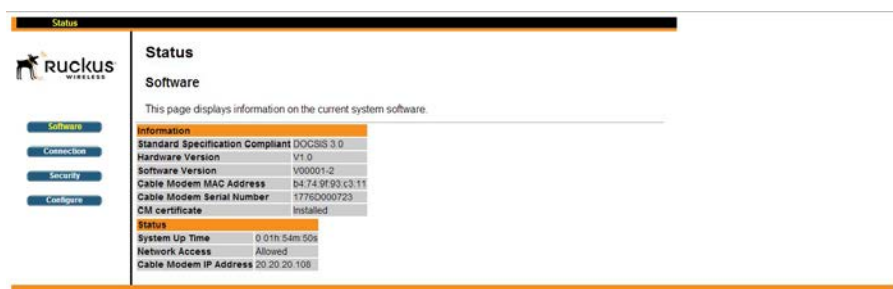

There are two tables on the *Software Status* page – *Information* and *Status*. [Table 7](#) and [Table 8](#) describe the information that these tables display.

Table 7. Information (software) table

Item	Description
Standard Specification Compliant	The standard with which the device is compliant.
Hardware Version	The version of the cable modem hardware.
Software Version	The version of the cable modem software.
Cable Modem MAC Address	The MAC address of the cable modem.
Cable Modem Serial Number	The serial number of the cable modem.
CM Certificate	Indicates whether a security certificate is installed.

Table 8. Status table

Item	Description
System Up Time	(***XXX** table needs updating if more (SFP) info is now available.) Indicates the time that has elapsed since the cable modem was last rebooted.
Network Access	Indicates whether or not the cable modem is connected to the network.
Cable Modem IP Address	The IP address assigned to the CM.

Continue with [Viewing the Connection Status](#).

Viewing the Connection Status

The *Connection Status* page displays information about the cable modem’s Hybrid Fiber Coax (HFC) and IP network connectivity, including its downstream and upstream channels and the IP address that is currently assigned to the cable modem.

- 1 Log into to the *Status* page as described in [Logging Into the CM Web Interface](#).
- 2 Click **Connection** in the left sidebar. The CM Web interface displays the *Connection Status* page.

NOTE The Downstream Power indicated in the Power column is accurate to +/-3dB.

Figure 10. Connection Status page - Page 1 of 2

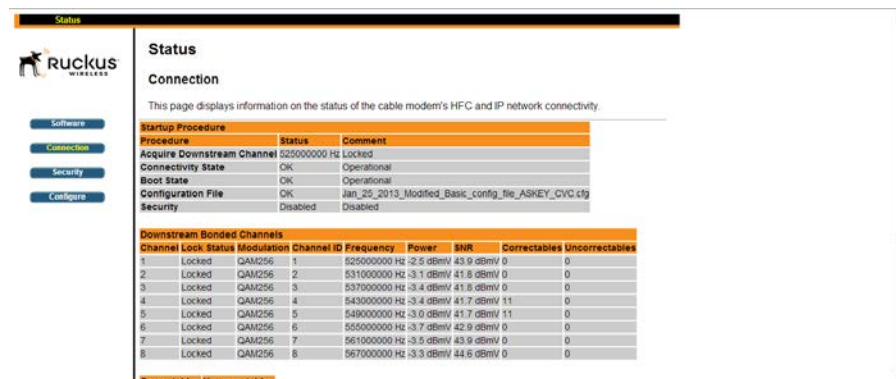

Figure 11. Connection Status page - Page 2 of 2

Downstream Bonded Channels								
Channel	Lock Status	Modulation	Channel ID	Frequency	Power	SNR	Correctables	Uncorrectables
1	Locked	QAM256	1	525000000 Hz	-2.5 dBmV	43.9 dBmV	0	0
2	Locked	QAM256	2	531000000 Hz	-3.1 dBmV	41.8 dBmV	0	0
3	Locked	QAM256	3	537000000 Hz	-3.4 dBmV	41.8 dBmV	0	0
4	Locked	QAM256	4	543000000 Hz	-3.4 dBmV	41.7 dBmV	11	0
5	Locked	QAM256	5	549000000 Hz	-3.0 dBmV	41.7 dBmV	11	0
6	Locked	QAM256	6	555000000 Hz	-3.7 dBmV	42.9 dBmV	0	0
7	Locked	QAM256	7	561000000 Hz	-3.5 dBmV	43.9 dBmV	0	0
8	Locked	QAM256	8	567000000 Hz	-3.3 dBmV	44.6 dBmV	0	0

Correctables		Uncorrectables	
0	0	0	0

Upstream Bonded Channels						
Channel	Lock Status	US Channel Type	Channel ID	Symbol Rate	Frequency	Power
1	Locked	ATDMA	4	5120 Ksym/sec	35400000 Hz	46.3 dBmV
2	Locked	ATDMA	3	5120 Ksym/sec	12800000 Hz	46.0 dBmV
3	Locked	ATDMA	2	5120 Ksym/sec	25600000 Hz	45.7 dBmV
4	Locked	ATDMA	1	5120 Ksym/sec	32000000 Hz	47.2 dBmV

CM IP Address Duration		Expires	
20.20.20.108	D: 30 H: 01 M: 00 S: 00	Fin Sep 26 17:37:11 2014	

Current System Time: Wed Aug 27 18:36:19 2014

Continue with [Configuring the Downstream Frequency](#).

Configuring the Downstream Frequency

The *Configure Status* page allows you to set the downstream frequency for the cable modem. Configuring the downstream frequency enables the device to quickly obtain a direct frequency lock with the CMTS upon bootup and helps to save several minutes of scanning for an available downstream frequency from the CMTS.

- 1 Log into the *Status* page as described in [Logging Into the CM Web Interface](#).
- 2 Click **Configure** in the left sidebar. The CM Web interface displays the *Configure Status* page. See [Figure 12](#).

Figure 12. Configure Status page

The screenshot shows the 'Configure Status' page in the Ruckus Wireless CM Web Interface. The page has a sidebar with navigation options: Software, Connection, Security, and Configure. The main content area is titled 'Status' and 'Configure'. Below the title, it says 'This page allows configure specified downstream frequency.' There is a section for 'Configure Downstream Frequency' with a text box containing '525000000' and a 'Set Values and Reboot' button.

- 3 In the *Configure DS Frequency* text box, enter the downstream frequency (in Hertz) that you want the cable modem to use to connect to the CMTS when it boots up.
- 4 Click **Set Values and Reboot** to have the cable modem save your changes and reboot.

Continue with [Administering Cable Modem Passwords](#).

Administering Cable Modem Passwords

The parameters on the *Security Status* page allow you to change the CM login and password, and/or restore the factory defaults.

- 1 Log into to the *Status* page as described in [Logging Into the CM Web Interface](#).
- 2 Click **Security** in the left sidebar. The CM Web interface displays the *Security Status* page.

Figure 13. Security Status page

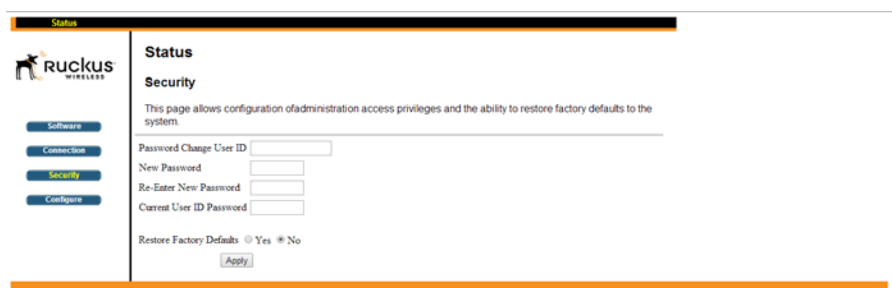

- 3 Ruckus Wireless recommends that you change the login and/or password as follows:
 - a Enter a new CM user ID in *Password Change User ID*.
 - b Enter a new CM user password in *New Password*.
 - c If you are changing the password, then re-enter the new CM user password in *Re-Enter New Password*.
 - d Enter the existing (before change) CM user password in *Current User ID Password*.
- 4 Restore the factory defaults as follows:
 - Select the *Restore Factory Defaults Yes* button to reset all the CM parameters to the factory default settings after the next reboot.
 - Select the *Restore Factory Defaults No* button to prevent a reset all CM parameters to the factory defaults after the next reboot.
- 5 If you have made any changes on the *Security Status* page, then click **Apply**.
 - If you have selected the *Restore Factory Defaults Yes*, then the CM reboots and resets all CM parameters to the factory defaults.
 - If you have selected the *Restore Factory Defaults No*, then the CM Web interface saves your changes and returns you to the *Security Status* page.

Continue with [Re-Installing an Access Plug or Hardline Adapter](#).

Re-Installing an Access Plug or Hardline Adapter

If you have replaced the F connector/stinger/hardline adapter or removed a screw-in access plug (to connect the administrative computer, or use the AP and CM reset button), then re-install the access plug or stinger as follows. If you have not removed any access plug, then continue with [Verifying CM and AP Operation](#).

- 1 Collect required tools and supplies:
 - Torque wrench and/or torque screwdriver with sockets and bits
 - 100% silicon sealant
- 2 If you have connected an administrative computer to the Ethernet cable to the T811-CM Ethernet port, then disconnect the cable.
- 3 Wipe any dirt or other contaminants off the access plug or stinger O-ring, and the O-ring mating surface.
- 4 Apply a thin film of 100% silicon sealant to the O-ring mating surface.
- 5 Using a 3/4" (19mm) socket and a torque screwdriver or wrench, tighten the F connector/stinger/hardline adapter to 1.7N.m or 15in-lbs.

Continue with [Verifying CM and AP Operation](#).

Verifying CM and AP Operation

The cable operator has their own CM and AP acceptance tests. Make sure you verify the T811-CM operation as defined in the acceptance tests before leaving the installation site.

Operating and Troubleshooting the T811-CM

4

This section lists some information that may be useful in operating and troubleshooting the T811-CM. Topics discussed include:

- [Retrieving the CM's MAC Address](#)
- [Rebooting and Resetting the T811-CM](#)
- [How Radio Frequency Scanning Works](#)

Retrieving the CM's MAC Address

There are some configuration operations that require you to enter the CM's MAC address. The CM and AP MAC addresses are printed on labels on the outside of the T811-CM, as described in [AP and CM MAC Addresses, Connectors and Ground Point](#).

Retrieving the CM's MAC Address

There are some configuration operations that require you to enter the CM's MAC address. The CM and AP MAC addresses are printed on labels on the outside of the T811-CM, as described in [AP and CM MAC Addresses, Connectors and Ground Point](#).

If you cannot find the CM's MAC address on the T811-CM, you can retrieve it via the CMTS using the AP and CM command line interfaces:

- [Retrieving the CM's MAC Address using the CM CLI](#)
- [Retrieving the CM's MAC Address using the AP CLI](#)

Retrieving the CM's MAC Address using the CM CLI

Use CM command line interface via the CMTS to retrieve the CM's MAC address.

- 1 Obtain the IP address assigned to the CM. You can obtain this information from the DHCP server at the CMTS.
- 2 Connect an administrative computer to the same subnet as the T811-CM.
- 3 Start the Telnet or SSH client program on the administrative computer.
- 4 Log onto the CM using Telnet or SSH with the following logon details:
 - User name: **super**
 - Password: **mso-admin**
- 5 When the command prompt appears, enter the following command:

```
cd n
cd hal
mac_address 1
```

The CLI displays the CM's MAC address.

Retrieving the CM's MAC Address using the AP CLI

Use AP command line interface via the CMTS to retrieve the CM's MAC address.

- 1 Obtain the IP address assigned to the AP. You can obtain this information from the DHCP server at the CMTS.

- 2 Connect an administrative computer to the same subnet as the T811-CM.
- 3 On the administrative computer, start the Telnet or SSH (secure shell) client program.
- 4 Log onto to the AP using Telnet or SSH with the following logon details:
 - User names: **super**
 - Password: **sp-admin**
- 5 When command prompt appears, enter the following command:

```
get cm supportinfo
```

```
### Basic Info ###  
MAC Address: C0 xx xx xx xx xx  
Software Version: V9xxxxx  
WAN IP Address: 10.225.xxx.xxx
```

The command prompt displays the CM's MAC address.

Rebooting and Resetting the T811-CM

Refer to [Appendix C: Replacing the F Connector Adapter](#) for instructions on rebooting and resetting the AP and CM parts of the T811-CM.

How Radio Frequency Scanning Works

The following steps describe how a DOCSIS-compliant T811-CM performs radio frequency scanning:

- 1 Looks at the last “known good channel” (repeat this every 64 channel checks).
- 2 Checks the sixteen last known frequencies (repeat this every 32 channel checks).
- 3 Scans STD standard channels (where the center of the channel is an integer spaced by 6MHz), first [from 93MHz to 999MHz - 152 channels].
- 4 Scans the harmonically related carrier (HRC) channels, which moves the channels 1.25MHz off the standard frequencies so the video carriers are all related by 6MHz [from 91.75 to 997.5MHz - 152 channels].

A complete frequency scan requires approximately 469 channel checks. Since each channel takes about 0.6 seconds, a full scan is done every 281 seconds (a little under 5 minutes).

NOTE The scanning of generic DOCSIS channels is required the first time the T811-CM connects to an MSO. After the initial scan, the T811-CM is able to retrieve the local country frequency plan without a complete scan during its normal operation.

The following are some of the post-installation tasks that Ruckus Wireless recommends. Refer to the *Ruckus Wireless Outdoor Access Point User Guide* for more information on configuring and managing the AP.

Changing the Administrative Password

Management access to the Web interface of the AP is controlled through administrative user name and password. As soon as you complete the AP setup, make sure you log on to the AP's Web interface and change the default administrative user name and password. This will help prevent unauthorized users from logging in to the AP's Web interface and changing the AP settings to compromise your network.

Configuring the Security Settings

Unlike wired networks, anyone with a compatible wireless adapter can receive wireless data transmissions from your network. To prevent unauthorized users from entering your wireless network and accessing your computers and files, Ruckus Wireless strongly recommends enabling and configuring wireless security on the AP. The AP supports several types of encryption and authentication methods to help prevent unauthorized access to your wireless network.

Configuring Advanced Settings and Features

The AP has been configured for basic operation. However, the Ruckus Wireless AP supports many advanced settings and features. Refer to the *Ruckus Wireless Outdoor Access Point User Guide* for instructions on how to configure the advanced setting and feature parameters.



Reading Related Documentation

The latest versions of Ruckus Wireless product documentation are available for download on the Ruckus Wireless Support Web site at <http://support.ruckuswireless.com/documents>

Appendix A: Ruckus Wireless Factory- and Customer-Supplied Parts

A

Table 9. Factory-supplied and customer-supplied parts

Part		Ruckus Wireless P/N	T811-CM Kit or Customer	Notes
1m lugged earth ground wire		--	T811-CM kit	
Cable power tap and connecting cable		--	Customer supplied	Antronix MGT2000-SDPE tap, or equivalent

Appendix B: T811-CM Mounting Dimensions and Weight

B

Dimensions

Figure 14. T811-CM length--all dimensions in millimeters and [inches] (**XX** need new drawings)

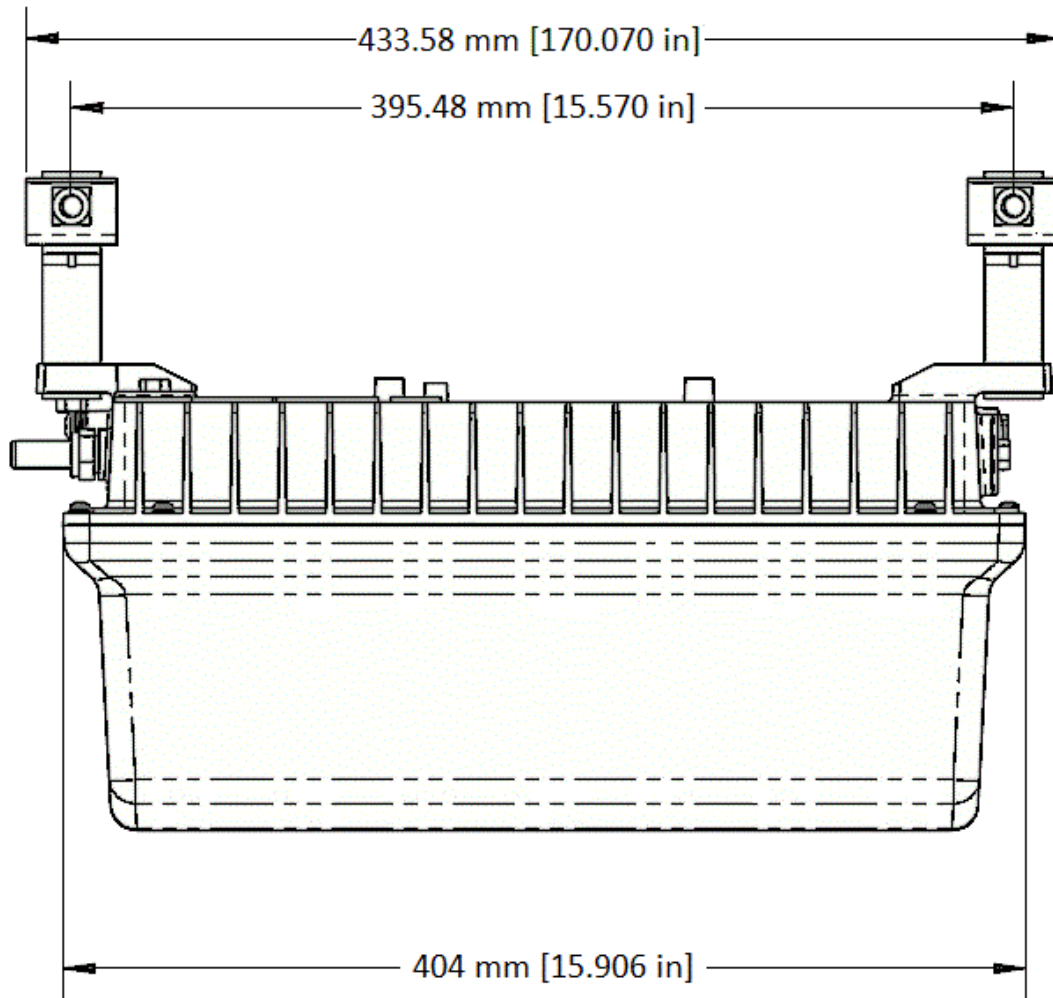
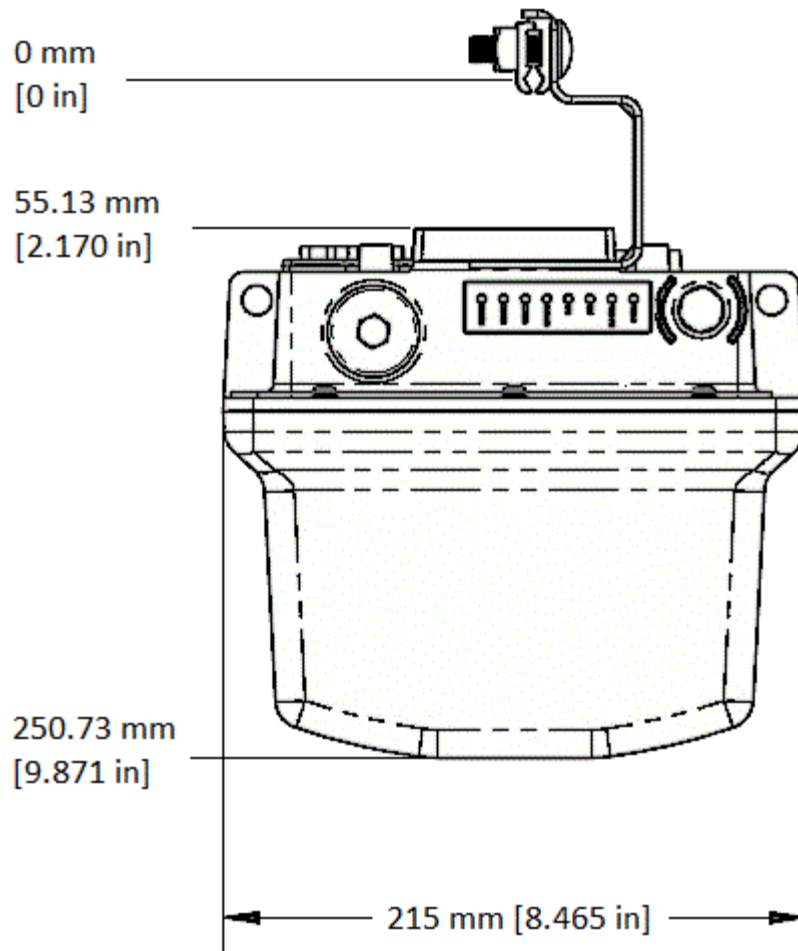

Figure 15. T811-CM height and width--all dimensions in millimeters and [inches] (***) need new drawings



Weight

The T811-CM weighs 9.5 pounds. For other specifications, refer to the Ruckus Wireless data sheet.
(***XX** need new weight specs.)

Appendix C: Replacing the F Connector Adapter

C

(**XXX** need new procedure)If you need to replace the 3/4" KS male to F female port adapter (stinger or hardline adapter), then complete the following:

- 1 Collect the following tools and supplies:
 - Customer-supplied 3/4" KS male to F female port adapter (stinger)
 - 7/16" (11mm) and 3/4" (19mm) open-end wrenches
 - No. 2 Phillips screwdriver
 - Torque wrench and/or torque screwdriver with sockets and bits
 - Wire cutters
 - 100% silicon sealant
- 2 Using a 7/16" wrench, unscrew and remove the stinger screw-in access plug (1 in [Figure 16](#)) next to the stinger F connector (2 in [Figure 16](#)).

Figure 16. F connector and plug

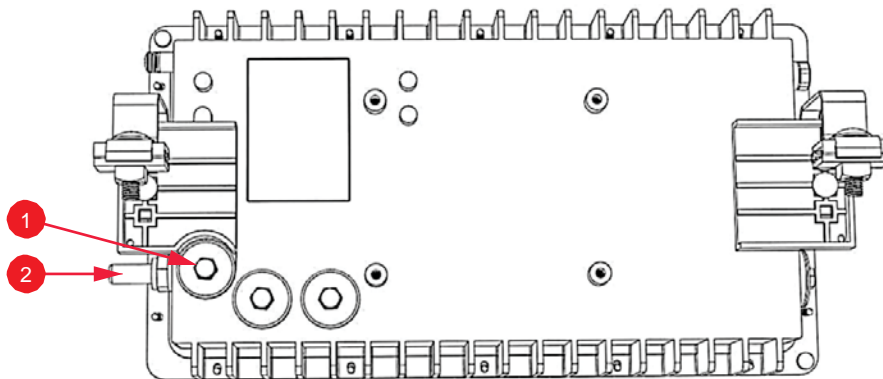

- 3 Using a No. 2 Phillips screwdriver, loosen the Phillips retaining screw holding down the existing stinger pin only enough to release the stinger pin. **DO NOT** remove the Phillips retaining screw, or it could fall down into the chassis of the T811-CM.
- 4 Using the 3/4" wrench, unscrew and remove the stinger (2 in [Figure 16](#)).
- 5 Using the wire cutters, cut the new stinger pin to the same length as the old stinger pin. [Figure 17](#) shows the stinger pin length.

Figure 17. F connector stinger pin length

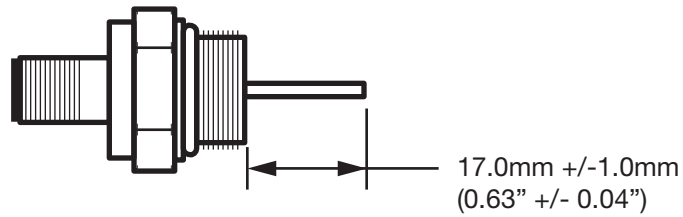

NOTE The Phillips retaining screw (1 in [Figure 18](#)) holding down the stinger pin (2 in [Figure 18](#)) uses a flat washer (3 in [Figure 18](#)) to make good electrical contact with the stinger pin. The flat washer must go between the Phillips retaining screw head and the stinger pin.

- 6 Refer to [Figure 18](#). Gently insert the new stinger so the shortened stinger pin (2 in [Figure 18](#)) slides under the flat washer and the Phillips retaining screw head (3 and 1 in [Figure 18](#)).

Figure 18. F connector replacement detail

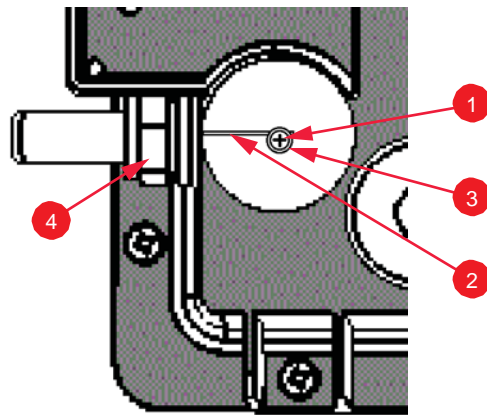

- 7 Using a torque screwdriver or wrench, tighten the stinger adapter (4 in [Figure 18](#)) to 1.7N.m or 15in-lbs as described in [Re-Installing an Access Plug or Hardline Adapter](#).
- 8 Make sure that the flat on the bottom of the stinger 3/4" hexagonal head contacts the T811-CM chassis.
- 9 Using a torque screwdriver with a No. 2 Phillips bit, tighten the Phillips retaining screw to 0.8N.m or 7in-lbs.
- 10 Using a torque screwdriver or wrench, tighten the stinger access plug (1 in [Figure 16](#)) to 1.7N.m or 15in-lbs as described in [Re-Installing an Access Plug or Hardline Adapter](#).

You have completed replacing the stinger/hardline adapter.

Appendix D: Rebooting and Resetting the T811-CM

D

- [Rebooting and Resetting the AP and CM](#)
- [Rebooting and Factory-Resetting the CM](#)

Rebooting and Resetting the AP and CM

CAUTION! Performing this procedure resets the AP and CM parts of the T811-CM to their factory default settings.

If you want to reset only the CM component to its factory default settings, then perform the procedure described in [Rebooting and Factory-Resetting the CM](#) instead.

CAUTION! Resetting the AP and CM to factory default settings erases all the settings that you have previously configured. Also note that resetting and/or rebooting the AP and CM disrupts all wireless network communications through this device.

There are different ways to reboot or reset the AP and CM parts of the T811-CM:

- [Using the Reset Button Inside the AP](#)
- [Remotely Rebooting and Factory Resetting the AP](#)

Using the Reset Button Inside the AP

You can reset the AP and CM to their factory default settings by pressing the reset button located under the screw-in reset button and diagnostic Ethernet port access plug on the T811-CM.

- 1 Make sure that the AP is powered.
- 2 Use a 7/16" (11mm) socket or wrench to remove the screw-in reset button and diagnostic Ethernet port access plug. See [Figure 6](#) for the location of the screw-in reset button and diagnostic Ethernet port plug.
- 3 Locate the reset button under the access plug. See [Figure 23](#) for the location of the reset button inside the T811-CM.

Figure 23. Location of the reset button

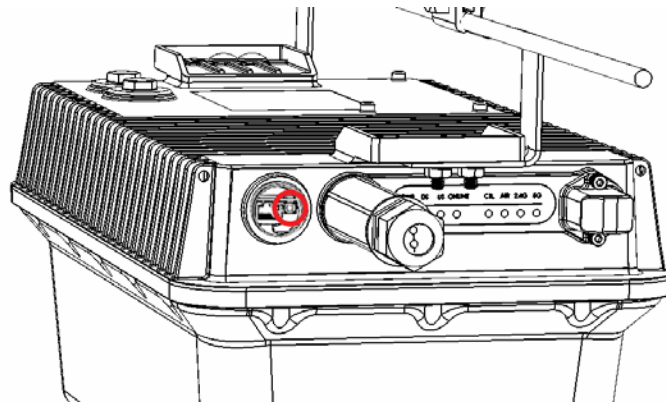

- 4 Using a pen or a similar pointed object, momentarily press the reset button on the reset adapter assembly to reboot the AP and CM, or press and hold the reset button for 1-4 seconds to reboot, or 5-10 seconds to reset the AP and CM to factory defaults.
- 5 Using a torque screwdriver or wrench, tighten the access plug to 1.7N.m or 15in-lbs as described in [Re-Installing an Access Plug or Hardline Adapter](#).

You have completed resetting the AP and CM to their factory default settings and/or rebooting the AP and CM.

Remotely Rebooting and Factory Resetting the AP

NOTE Before starting this procedure, you must first obtain the related MIBs from Ruckus Wireless. Contact your authorized Ruckus Wireless sales representative or Ruckus Wireless Support. Visit <http://support.ruckuswireless.com/contacts> for Ruckus Wireless Support contact information.

- 1 Connect the administrative computer to the same network as the T811-CM.
- 2 Start your MIB browser.
- 3 Load the Ruckus Wireless MIBs onto the MIB browser.
- 4 In the MIB browser, specify the IP address of the T811-CM AP. (You can obtain this information from the DHCP server on the network.)
- 5 Find the OID **1.3.6.1.4.1.25053.3.1.4.7.3** (ruckusZF7761CMControlLED). (**XX** need correct MIB)
- 6 Then do the following:
 - To soft reset the AP, set the value to **10** (softResetAP).
 - To hard set the AP, set the value to **11** (powerCycleAP).
 - To factory-reset the AP, set the value to **12** (factoryResetAP).

You have completed remotely rebooting or factory-resetting the access point using SNMP.

Rebooting and Factory-Resetting the CM

CAUTION! Factory resetting returns the CM part of the T811-CM to its factory default settings.

NOTE Before starting this procedure, you must first obtain the related MIBs from Ruckus Wireless. Contact your authorized Ruckus Wireless sales representative or Ruckus Wireless Support. Visit <http://support.ruckuswireless.com/contacts> for Ruckus Wireless Support contact information (login required).

- 1 Connect the administrative computer to the same network as the T811-CM.
- 2 Start your MIB browser.
- 3 Load the Ruckus Wireless MIBs onto the MIB browser.
- 4 In the MIB browser, specify the IP address of the T811-CM access point or cable modem. (You can obtain this information from the DHCP server on the network.)
- 5 Find the OID **1.3.6.1.4.1.25053.3.1.4.7.3** (ruckusZF7761CMControlLED). (***) need correct MIB)
- 6 Then do the following:
 - To soft reset the CM, set the value to **13** (softResetCM).
 - To hard reset the CM, set the value to **14** (powerCycleCM).
 - To factory-reset the CM, set the value to **15** (factoryResetCM).

You have completed resetting or factory-resetting the cable modem using SNMP.





Copyright © 2006-2017. Ruckus Wireless, Inc.
350 West Java Dr. Sunnyvale, CA 94089. USA
www.ruckuswireless.com