

Ruckus ICX 7150 Switch Hardware Installation Guide

Copyright Notice and Proprietary Information

Copyright 2017 Brocade Communications Systems, Inc. All rights reserved.

No part of this documentation may be used, reproduced, transmitted, or translated, in any form or by any means, electronic, mechanical, manual, optical, or otherwise, without prior written permission of or as expressly provided by under license from Brocade.

Destination Control Statement

Technical data contained in this publication may be subject to the export control laws of the United States of America. Disclosure to nationals of other countries contrary to United States law is prohibited. It is the reader's responsibility to determine the applicable regulations and to comply with them.

Disclaimer

THIS DOCUMENTATION AND ALL INFORMATION CONTAINED HEREIN ("MATERIAL") IS PROVIDED FOR GENERAL INFORMATION PURPOSES ONLY. BROCADE and RUCKUS WIRELESS, INC. AND THEIR LICENSORS MAKE NO WARRANTY OF ANY KIND, EXPRESS OR IMPLIED, WITH REGARD TO THE MATERIAL, INCLUDING, BUT NOT LIMITED TO, THE IMPLIED WARRANTIES OF MERCHANTABILITY, NON-INFRINGEMENT AND FITNESS FOR A PARTICULAR PURPOSE, OR THAT THE MATERIAL IS ERROR-FREE, ACCURATE OR RELIABLE. BROCADE and RUCKUS RESERVE THE RIGHT TO MAKE CHANGES OR UPDATES TO THE MATERIAL AT ANY TIME.

Limitation of Liability

IN NO EVENT SHALL BROCADE or RUCKUS BE LIABLE FOR ANY DIRECT, INDIRECT, INCIDENTAL, SPECIAL OR CONSEQUENTIAL DAMAGES, OR DAMAGES FOR LOSS OF PROFITS, REVENUE, DATA OR USE, INCURRED BY YOU OR ANY THIRD PARTY, WHETHER IN AN ACTION IN CONTRACT OR TORT, ARISING FROM YOUR ACCESS TO, OR USE OF, THE MATERIAL.

Trademarks

Ruckus Wireless, Ruckus, the bark logo, BeamFlex, ChannelFly, Dynamic PSK, FlexMaster, Simply Better Wireless, SmartCell, SmartMesh, SmartZone, Unleashed, ZoneDirector and ZoneFlex are trademarks of Ruckus Wireless, Inc. in the United States and in other countries. Brocade, the B-wing symbol, MyBrocade, and ICX are trademarks of Brocade Communications Systems, Inc. in the United States and in other countries. Other trademarks may belong to third parties.

Contents

Preface	7
Document Conventions.....	7
Notes, Cautions, and Warnings.....	7
Command Syntax Conventions.....	7
Document Feedback.....	8
Ruckus Product Documentation Resources.....	8
Online Training Resources.....	8
Contacting Ruckus Customer Services and Support.....	9
What Support Do I Need?.....	9
Open a Case.....	9
Self-Service Resources.....	9
About This Document	11
Supported hardware and software.....	11
What's new in this document.....	12
Device Overview	13
Hardware features.....	13
License options.....	14
Port-side view.....	15
Nonport-side view.....	17
Device management options.....	19
LRM Adapter support.....	19
Preparing for the Installation	21
Safety precautions.....	21
General precautions.....	21
ESD precautions.....	21
Power precautions.....	22
Lifting and weight-related precautions.....	22
Laser precautions.....	23
Facility requirements.....	23
Quick installation checklist.....	24
Pre-installation tasks.....	24
Installation and initial configuration.....	24
Shipping carton contents.....	26
Mounting the Device	27
Mounting options.....	27
Precautions specific to mounting.....	27
Mounting on a desktop or flat surface.....	28
Mounting the compact device with a magnet.....	30
Attaching the magnet sheet to the device.....	31
Mounting the device on a metal surface or metal wall.....	32
Mounting the device under a metal desk.....	34
Mounting the compact device under a fixed surface.....	36
Mounting the compact device directly on a wall.....	39
Mounting on a wall using the wall mount brackets.....	43

Mounting on a two-post rack.....	48
Installing the 1U, 1.5U, and 2U Universal Kit for Four Post Racks (XBR-R000295).....	53
Time and items required.....	54
Parts list.....	54
Flush-front mounting the device in the rack.....	55
Attaching the front brackets.....	56
Attaching the bracket extensions to the device.....	57
Installing the device in the rack.....	58
Attaching the rear brackets to the extensions.....	59
Attaching the rear brackets to the rack posts.....	61
Flush-rear (recessed) mounting the device in the rack.....	62
Attaching the front brackets to the rear of the device.....	62
Attaching the bracket extensions to the front of the device.....	63
Installing the device in the rack.....	64
Attaching the rear brackets to the bracket extensions at the front of the device.....	65
Attaching the rear brackets to the front rack posts.....	67
Connecting ICX 7150 Devices in a Stack.....	69
Stacking configuration requirements.....	69
ICX 7150 stacking ports.....	69
ICX 7150 stacking topologies.....	71
Initial Setup and Verification.....	75
Items required.....	75
Providing power to the device.....	75
Establishing a first-time connection to the console port.....	76
Recovering from a lost password.....	78
Configuring an IP address for the device.....	79
Customizing the host name and chassis name	79
Setting the date and time.....	80
Establishing a connection to the out-of-band management port.....	80
Getting in-band access.....	81
Verifying the correct operation.....	81
Backing up the running configuration.....	81
Installing Transceivers and Cables.....	83
Time and items required.....	83
Precautions specific to transceivers and cables.....	83
Managing cables.....	84
Installing the Ethernet RJ-45 cables.....	84
Cleaning the fiber-optic connectors.....	86
Installing a new fiber-optic transceiver.....	86
Cabling a fiber-optic transceiver.....	87
Replacing a fiber-optic transceiver.....	88
Monitoring the Device.....	91
Interpreting port-side LEDs.....	91
System LEDs.....	93
OOB LED.....	97
RJ-45 Ethernet port status LED in default mode.....	97
Interpreting nonport-side LEDs.....	98
Pinging an IP address.....	98

Tracing a route.....	98
Digital optical monitoring.....	99
Monitoring power and cooling.....	99
Ruckus ICX 7150 Switch Technical Specifications.....	101
System specifications.....	101
Ethernet.....	102
LEDs.....	102
Other.....	103
Weight and physical dimensions.....	103
Environmental requirements.....	103
Power supply specifications (per PSU).....	104
Power consumption (idle configuration).....	105
Power consumption (typical configuration).....	106
Power consumption (maximum configuration).....	107
Data port specifications (Ethernet).....	108
Serial port specifications (pinout RJ-45).....	109
Serial port specifications (protocol).....	109
Memory specifications.....	109
Regulatory compliance (EMC).....	110
Regulatory compliance (safety).....	110
Regulatory compliance (environmental).....	110
Regulatory Statements.....	111
CE statement.....	111
China ROHS.....	111
BSMI statement (Taiwan).....	111
Canadian requirements.....	112
China CCC statement.....	112
Europe and Australia (CISPR 32 Class A Warning).....	113
FCC warning (US only).....	113
Germany statement.....	113
KCC statement (Republic of Korea).....	113
VCCI statement.....	113
Cautions and Danger Notices.....	115
Cautions.....	115
General cautions.....	115
Electrical cautions.....	117
Danger Notices.....	118
General dangers.....	119
Electrical dangers.....	119
Dangers related to equipment weight.....	121
Laser dangers.....	122

Preface

- Document Conventions..... 7
- Command Syntax Conventions..... 7
- Document Feedback..... 8
- Ruckus Product Documentation Resources..... 8
- Online Training Resources..... 8
- Contacting Ruckus Customer Services and Support..... 9

Document Conventions

The following tables list the text and notice conventions that are used throughout this guide.

TABLE 1 Text conventions

Convention	Description	Example
monospace	Identifies command syntax examples.	<code>device(config)# interface ethernet 1/1/6</code>
bold	User interface (UI) components such as screen or page names, keyboard keys, software buttons, and field names	On the Start menu, click All Programs .
<i>italics</i>	Publication titles	Refer to the <i>Ruckus Small Cell Release Notes</i> for more information

Notes, Cautions, and Warnings

Notes, cautions, and warning statements may be used in this document. They are listed in the order of increasing severity of potential hazards.

NOTE

A NOTE provides a tip, guidance, or advice, emphasizes important information, or provides a reference to related information.



CAUTION

A CAUTION statement alerts you to situations that can be potentially hazardous to you or cause damage to hardware, firmware, software, or data.



DANGER

A DANGER statement indicates conditions or situations that can be potentially lethal or extremely hazardous to you. Safety labels are also attached directly to products to warn of these conditions or situations.

Command Syntax Conventions

Bold and italic text identify command syntax components. Delimiters and operators define groupings of parameters and their logical relationships.

Convention

bold text

Description

Identifies command names, keywords, and command options.

Convention	Description
<i>italic text</i>	Identifies a variable.
[]	Syntax components displayed within square brackets are optional.
{ x y z }	Default responses to system prompts are enclosed in square brackets. A choice of required parameters is enclosed in curly brackets separated by vertical bars. You must select one of the options.
x y	A vertical bar separates mutually exclusive elements.
< >	Nonprinting characters, for example, passwords, are enclosed in angle brackets.
...	Repeat the previous element, for example, <i>member</i> { <i>member</i> ...}.
\	Indicates a “soft” line break in command examples. If a backslash separates two lines of a command input, enter the entire command at the prompt without the backslash.

Document Feedback

Ruckus is interested in improving its documentation and welcomes your comments and suggestions.

You can email your comments to Ruckus at: docs@ruckuswireless.com

When contacting us, please include the following information:

- Document title and release number
- Document part number (on the cover page)
- Page number (if appropriate)
- For example:
 - Ruckus Small Cell Alarms Guide SC Release 1.3
 - Part number: 800-71306-001
 - Page 88

Ruckus Product Documentation Resources

Visit the Ruckus website to locate related documentation for your product and additional Ruckus resources.

Release Notes and other user documentation are available at <https://support.ruckuswireless.com/documents>. You can locate documentation by product or perform a text search. Access to Release Notes requires an active support contract and Ruckus Support Portal user account. Other technical documentation content is available without logging into the Ruckus Support Portal.

White papers, data sheets, and other product documentation are available at <https://www.ruckuswireless.com>.

Online Training Resources

To access a variety of online Ruckus training modules, including free introductory courses to wireless networking essentials, site surveys, and Ruckus products, visit the Ruckus Training Portal at <https://training.ruckuswireless.com>.

Contacting Ruckus Customer Services and Support

The Customer Services and Support (CSS) organization is available to provide assistance to customers with active warranties on their Ruckus Networks products, and customers and partners with active support contracts.

For product support information and details on contacting the Support Team, go directly to the Support Portal using <https://support.ruckuswireless.com>, or go to <https://www.ruckuswireless.com> and select **Support**.

What Support Do I Need?

Technical issues are usually described in terms of priority (or severity). To determine if you need to call and open a case or access the self-service resources use the following criteria:

- Priority 1 (P1)—Critical. Network or service is down and business is impacted. No known workaround. Go to the **Open a Case** section.
- Priority 2 (P2)—High. Network or service is impacted, but not down. Business impact may be high. Workaround may be available. Go to the **Open a Case** section.
- Priority 3 (P3)—Medium. Network or service is moderately impacted, but most business remains functional. Go to the **Self-Service Resources** section.
- Priority 4 (P4)—Low. Request for information, product documentation, or product enhancements. Go to the **Self-Service Resources** section.

Open a Case

When your entire network is down (P1), or severely impacted (P2), call the appropriate telephone number listed below to get help:

- Continental United States: 1-855-782-5871
- Canada: 1-855-782-5871
- Europe, Middle East, Africa, and Asia Pacific, toll-free numbers are available at <https://support.ruckuswireless.com/contact-us> and Live Chat is also available.

Self-Service Resources

The Support Portal at <https://support.ruckuswireless.com/contact-us> offers a number of tools to help you to research and resolve problems with your Ruckus products, including:

- [Technical Documentation](https://support.ruckuswireless.com/documents)—<https://support.ruckuswireless.com/documents>
- [Community Forums](https://forums.ruckuswireless.com/ruckuswireless/categories)—<https://forums.ruckuswireless.com/ruckuswireless/categories>
- [Knowledge Base Articles](https://support.ruckuswireless.com/answers)—<https://support.ruckuswireless.com/answers>
- [Software Downloads and Release Notes](https://support.ruckuswireless.com/software)—<https://support.ruckuswireless.com/software>
- [Security Bulletins](https://support.ruckuswireless.com/security)—<https://support.ruckuswireless.com/security>

Using these resources will help you to resolve some issues, and will provide TAC with additional data from your troubleshooting analysis if you still require assistance through a support case or RMA. If you still require help, open and manage your case at https://support.ruckuswireless.com/case_management

About This Document

- Supported hardware and software..... 11
- What's new in this document..... 12

Supported hardware and software

This document is applicable for the various Ruckus ICX 7150 Ethernet switch models. The following tables list the device models and rack mount kits supported.

TABLE 2 OS-dependent models

Model number	Short description	Introduced (OS)	Currently supported (OS)	Notes
ICX 7150-48ZP	Sixteen 2.5G and thirty-two 1G Copper ports with eight SFP+ 1G/10-GbE ports - four are optical stacking or uplink ports, and four are uplink ports only	FastIron 08.0.61	Yes	hot-swap fan tray (up to 2 per switch) Mountable on a desktop, rack, or wall
ICX 7150-C12P	Twelve GbE (124 W) PoE+ ports with two 1-GbE uplink ports and two SFP+ 10-GbE optical stacking or uplink ports	FastIron 08.0.60	Yes	Fanless Mountable on a desktop, rack, wall, under a fixed surface, under a desk, under a shelf, or using a magnet
ICX 7150-24	Twenty-four GbE non-PoE ports with two 1-GbE uplink ports and four SFP+ 10-GbE optical stacking or uplink ports	FastIron 08.0.60	Yes	Fanless Mountable on a desktop, rack, or wall
ICX 7150-24P	Twenty-four GbE (370 W) PoE+ ports with two 1-GbE uplink ports and four SFP+ 10-GbE optical stacking or uplink ports	FastIron 08.0.60	Yes	Two built-in fans Support fanless mode Mountable on a desktop, rack, or wall
ICX 7150-48	Forty-eight GbE non-PoE ports with two 1-GbE uplink ports and four SFP+ 10-GbE optical stacking or uplink ports	FastIron 08.0.60	Yes	Fanless Mountable on a desktop, rack, or wall
ICX 7150-48P	Forty-eight GbE (370 W) PoE+ ports with two 1-GbE uplink ports and four SFP+ 10-GbE optical stacking or uplink ports	FastIron 08.0.60	Yes	Two built-in fans Support fanless mode Mountable on a desktop, rack, or wall
ICX 7150-48PF	Forty-eight GbE (740 W) PoE+ ports with two 1-GbE uplink ports and four SFP+ 10-GbE optical stacking or uplink ports	FastIron 08.0.60	Yes	Three built-in fans Mountable on a desktop, rack, or wall

About This Document

What's new in this document

NOTE

For ICX 7150-C12P, ICX 7150-24, ICX 7150-24P, ICX 7150-48, ICX 7150-48P, and ICX 7150-48PF, the AC power supply and fans are integrated with the device. The power supply or the fans are not field replaceable units (FRUs).

TABLE 3 Rack mount kits

Part number	Short description	Notes
ICX6400-C12-MGNT	Magnet mount kit for ICX 7150-C12P. This is not a rack mount kit. It is a magnet which could be used on a rack or on any surface that is magnetic such as a metal desk or cabinet	Not included with the device. Optionally orderable.
ICX7000-C12-RMK	Rack mount kit for ICX 7150-C12P on 2-post racks	Not included with the device. Optionally orderable.
ICX7000-C12-WMK	Wall / under desk mount kit for ICX 7150-C12P	Not included with the device. Optionally orderable.
ICX7000-RMK	Rack mount kit for 2-post racks	Included with 24-port and 48-port ICX 7150 models.
XBR-R000295	Universal rack mount kit for 4-post racks	Not included with the device. Optionally orderable.
RMK-LRM-ADP	Rack mount kit for LRM adapters. 1RU shelf can accommodate up to eight LRM adapters.	Not included with the device. Optionally orderable.

TABLE 4 Supported Adapter

Adapter Type	Short description	Notes
10G LRM SFP + Adapter	10GE SFP+ adapter for LRM optics	Not included with the device. Optionally orderable.

What's new in this document

The following table includes descriptions of new information added to this guide for the FastIron 08.0.70 release.

TABLE 5 Summary of enhancements in FastIron release 08.0.70

Feature	Description	Described in
Status Button Support	You must press the status mode selection button to select the status mode to display the corresponding status on the individual port status LED.	Status mode LEDs on page 94
Updates to LED	Several updates to the LED status.	Refer to the topics under Interpreting port-side LEDs on page 91.

Device Overview

- Hardware features..... 13
- License options..... 14
- Port-side view..... 15
- Nonport-side view..... 17
- Device management options..... 19
- LRM Adapter support..... 19

Hardware features

The Ruckus ICX 7150 offers the following hardware features and capabilities:

- ICX 7150 Z-series new for this release have the following features:
 - 16 2.5G+ Copper ports , that support 100M/1G/2.5G operation.
 - 32 1G Copper ports, that support 10M/100M/1G operation.
 - 8 SFP+ Fiber Ports supporting 1G/10G operation , in which the first 4 ports can be configured as stacking ports and the last 4 ports can be used for uplink/user port.
 - The ports 1/2/1 and 1/2/3 comes up in 10G speed by default.
 - The other ports comes up in 1G speed default , enabling 10G on these ports requires a software license. The ports 1/2/1 through 1/2/4 can be configured as stacking port or as user/uplink ports, where as 1/2/5 through 1/2/8 can be configured as user/uplink ports.
 - The first 16 ports complies with the power-over-HDBase T and each port can provide up to 90W.
 - The 32 1G Copper ports complies with the IEEE 802.3af/at standard.
- The table below lists the ICX 7150 switch models with 12, 24, or 48 auto-negotiating 10/100/1000 Mbps full duplex RJ-45 ports that can be used for downlink. These ports reside on slot 1 of the switch and can be non-PoE, PoE/POE+, or PoE+ ports.

TABLE 6 Switch model and corresponding IO port configurations

Switch model	Down Link Ports	PoE Ports	PoE Power	Up Link / Stacking Ports	Stacking Ports
ICX 7150-48	48x1G Copper	NA	NA	2x1G Copper + 4xSFP +	2xSFP+
ICX 7150-48P	48x1G Copper	48	370W	2x1G Copper + 4xSFP+	2xSFP+
ICX 7150-48PF	48x1G Copper	48	740W	2x1G Copper +4xSFP+	2xSFP+
ICX 7150-24	24x1G Copper	NA	NA	2x1G Copper + 4xSFP+	2xSFP+
ICX 7150-24P	24x1G Copper	24	370W	2x1G Copper + 4xSFP+	2xSFP+
ICX 7150-C12P	12x1G Copper	12	124W	2x1G Copper + 2xSFP	2xSFP+
ICX 7150-48ZP	16x2.5G Copper 32x 1G Copper	48	1480W	4xSFP + 8xSFP	4xSFP+

- Two 10/100/1000Base-T full duplex RJ-45 ports that can be used as uplink data ports. These ports reside on slot 2 of the switch.
- Two or four SFP+ optical 10-Gbps full duplex ports that can be used as stacking or uplink data ports. These ports reside on slot 3 of the switch.
- 10-GbE SFP+ dongle for LRM optic (Now supported in this release and onwards).
- Switch Port Extender (PE) mode (not supported currently).
- Maximum two FRUs power supply units.

Device Overview

License options

- Maximum two FRU fans for cooling the system with sides-to-back airflow.
- System LEDs
 - Power status
 - DIAG status
 - Master/Slave status
 - Cloud management status (not enabled currently).
 - Software update status (not enabled currently).
- Status mode LEDs (not enabled currently).
 - Port link status mode
 - Port speed status mode
 - PoE status mode
 - Member ID status mode
 - USB modes
- Management interfaces
 - Mode switch button (not enabled currently)
 - Reset button
 - Out-of-band (OOB) GbE management port
 - USB 2.0 general purpose Type-A port for file transfer with removable media (removable media not included with the device)
 - Type-C USB console port (Type-C USB cable not included with the device)
 - RS-232 console port with RJ-45 form factor (RJ-45 console cable not included with the device)

License options

The following table displays Ruckus ICX 7150 part number and license information available when upgrading to a licensed feature set. The licensed feature set includes the Premium Layer 3 license, and the Ports on Demand license. When upgrading to a licensed feature set, a Certificate of Entitlement (CoE) is shipped to you upon purchase of the license. The CoE is a “proof of purchase” for any features that have been purchased. The CoE is a .PDF certificate that has a unique serial number. One CoE is issued for each feature license that is purchased. Refer to the *Brocade FastIron Software Licensing Guide* for more details.

TABLE 7 Ruckus ICX 7150 SKU and license information

Part Number for Upgrades	License Name	Description
BR-ICX-7150-41U210-P-01	2X10G	CoE license to upgrade any ICX 7150 24-port or 48-port model from 4x1G SFP to a 2x1G SFP and 2x10G SFP+ uplink or stacking ports.
BR-ICX-7150-210U410R-P-01	4X10GR	CoE license to upgrade any ICX 7150 24-port or 48-port model from 2x1G SFP and 2x10G SFP+ to a 4x10G SFP+ uplink or stacking ports. Two default ports are available for stacking. Layer 3 Premium license features (OSPF, VRRP, PIM, PBR) are also included.
BR-ICX-7150-41U410R-P-01	4X10GR	CoE license to upgrade any ICX 7150 24-port or 48-port model from 4x1G SFP to a 4x10G SFP+ uplink or stacking ports. Two default ports are available for stacking. Layer 3 Premium license features (OSPF, VRRP, PIM, PBR) are also included.
BR-ICX-7150C-21U210R-P-01	2X10GR	CoE license to upgrade the ICX 7150-C12P switch from 2x1G SFP to a 2x10G SFP+ uplink or stacking ports. Layer 3 Premium license features (OSPF, VRRP, PIM, PBR) are also included.
BR-ICX-7150Z210U810R-P-01	8X10GR	CoE license to upgrade an ICX 7150-48ZP Z-Series switch from 6x1G SFP & 2x10G SFP+ to 8x10G SFP+ uplink or stacking ports. Layer 3 Premium license features (OSPF, VRRP, PIM, PBR) are also included.

Port-side view

FIGURE 1 Port-side view of ICX 7150-C12P

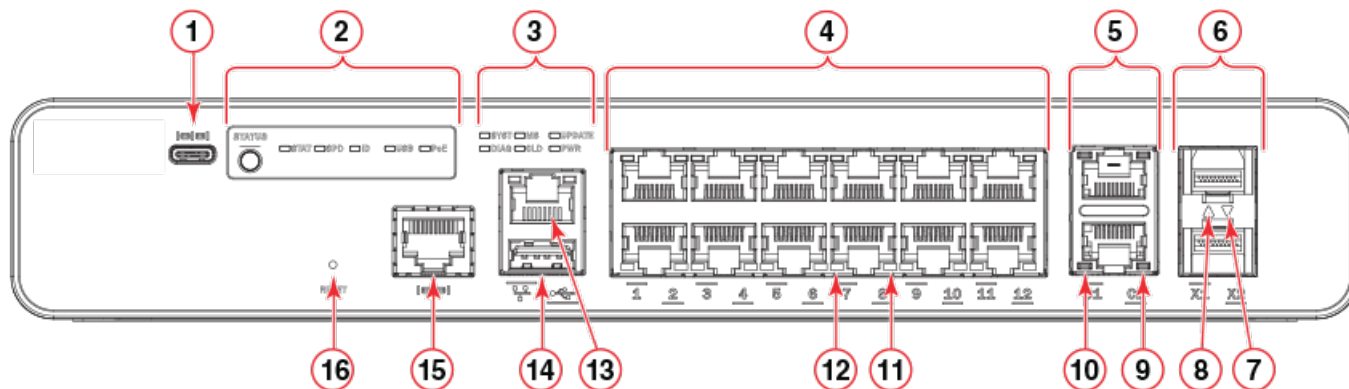

1. Type-C USB console port
2. Port status mode selection button and LEDs
3. System LEDs
4. Slot 1 (10/100/1000 Mbps RJ-45 downlink) ports
5. Slot 2 (10/100/1000 Mbps RJ-45 uplink) ports (half-duplex is not support on these ports)
6. Slot 3 (SFP+ uplink or stacking) ports
7. SFP+ Port X2 status LED
8. SFP+ Port X1 status LED
9. Reserved for future use
10. RJ-45 uplink port C2 RX/TX activity LED
11. Reserved for future use
12. RJ-45 downlink port 8 RX/TX activity LED
13. Out-of-band management port (RJ-45) with 2 LEDs
 - a. Left LED - Off: Link-down, Steady green: Link-up, and Blinking green: when there is RX/TX activity
 - b. Right LED - Off: when offline or linked at 10/100Mbps, Blinking green: when there is RX/TX activity
14. USB port
15. RJ-45 console port
16. Reset button

Device Overview
Port-side view

FIGURE 2 Port-side view of ICX 7150-24 and ICX 7150-24P

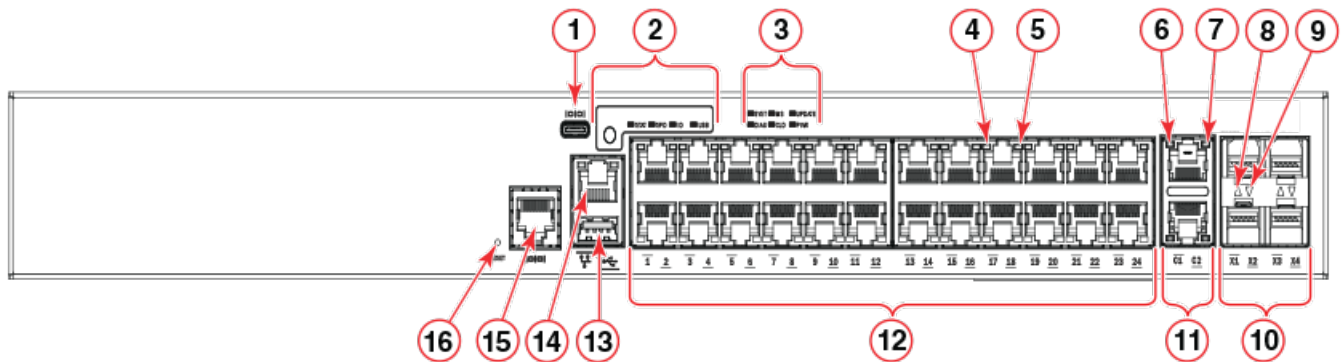

- | | |
|---------------------------------------------------------------------------------------------------------------------------------------------------------------------------------------------------------------------------------------------------------------------------------------------------------------------------------------------------------------------------------------------------------------------------------------------------------------------------------------------|------------------------------------------------------------------------------------------------------------------------------------------------------------------------------------------------------------------------------------------------------------------------------------------------------------------------------------------------------------------------------------------------------------------------------------------------------------------------------------------------------------------------------------------------------------------------------------------------------------------------------------------------|
| <ol style="list-style-type: none"> 1. Type-C USB console port 2. Port status mode selection button and LEDs 3. System LEDs 4. RJ-45 downlink port 17 status LED 5. RJ-45 downlink port 17 RX/TX activity LED 6. RJ-45 uplink port C1 status LED 7. RJ-45 uplink port C1 RX/TX activity LED 8. SFP+ port X1 status LED 9. SFP+ port X2 status LED 10. Slot 3 (SFP+ uplink or stacking) ports | <ol style="list-style-type: none"> 11. Slot 2 (10/100/1000 Mbps RJ-45 uplink) ports (half-duplex is not support on these ports) 12. Slot 1 (10/100/1000 Mbps RJ-45 downlink) ports 13. USB port 14. Out-of-band management port (RJ-45) with 2 LEDs <ol style="list-style-type: none"> a. Left LED - Off: Link-down, Steady green: Link-up, and Blinking green: when there is RX/TX activity b. Right LED - Off: when offline or linked at 10/100Mbps, Blinking green: when there is RX/TX activity 15. RJ-45 console port 16. Reset button |
|---------------------------------------------------------------------------------------------------------------------------------------------------------------------------------------------------------------------------------------------------------------------------------------------------------------------------------------------------------------------------------------------------------------------------------------------------------------------------------------------|------------------------------------------------------------------------------------------------------------------------------------------------------------------------------------------------------------------------------------------------------------------------------------------------------------------------------------------------------------------------------------------------------------------------------------------------------------------------------------------------------------------------------------------------------------------------------------------------------------------------------------------------|

FIGURE 3 Port-side view of ICX 7150-48, ICX 7150-48P, and ICX 7150-48PF

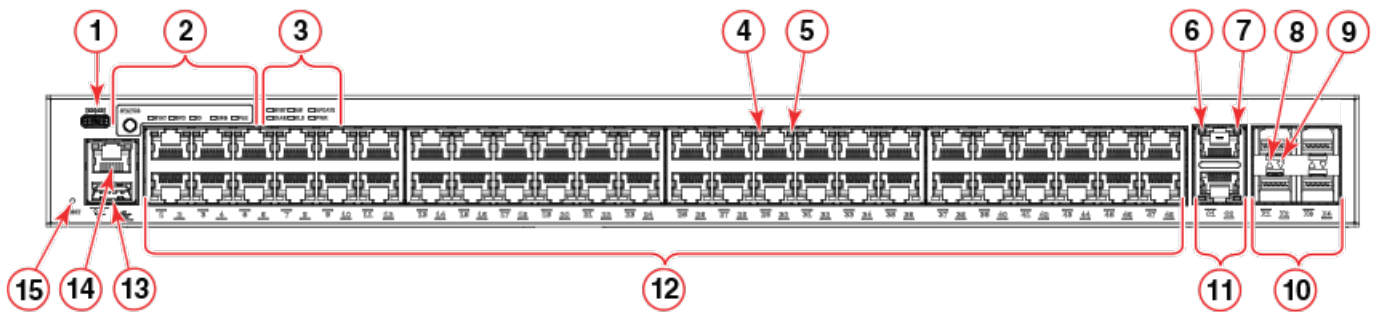

- | | |
|---------------------------------------------------------------------------------------------------------------------------------------------------------------------------------------------------------------------------------------------------------------------------------------------------------------------------------------------------------------------------------------------------------------------------------------------------------------------------------------------|---------------------------------------------------------------------------------------------------------------------------------------------------------------------------------------------------------------------------------------------------------------------------------------------------------------------------------------------------------------------------------------------------------------------------------------------------------------------------------------------------------------------------------------------------------------------------------------------------------------------|
| <ol style="list-style-type: none"> 1. Type-C USB console port 2. Port status mode selection button and LEDs 3. System LEDs 4. RJ-45 downlink port 29 status LED 5. RJ-45 downlink port 29 RX/TX activity LED 6. RJ-45 uplink port C1 status LED 7. RJ-45 uplink port C1 RX/TX activity LED 8. SFP+ port X1 status LED 9. SFP+ port X2 status LED 10. Slot 3 (SFP+ uplink or stacking) ports | <ol style="list-style-type: none"> 11. Slot 2 (10/100/1000 Mbps RJ-45 uplink) ports (half-duplex is not support on these ports) 12. Slot 1 (10/100/1000 Mbps RJ-45 downlink) ports 1-48 13. USB port 14. Out-of-band management port (RJ-45) with 2 LEDs <ol style="list-style-type: none"> a. Left LED - Off: Link-down, Steady green: Link-up, and Blinking green: when there is RX/TX activity b. Right LED - Off: when offline or linked at 10/100Mbps, Blinking green: when there is RX/TX activity 15. Reset button |
|---------------------------------------------------------------------------------------------------------------------------------------------------------------------------------------------------------------------------------------------------------------------------------------------------------------------------------------------------------------------------------------------------------------------------------------------------------------------------------------------|---------------------------------------------------------------------------------------------------------------------------------------------------------------------------------------------------------------------------------------------------------------------------------------------------------------------------------------------------------------------------------------------------------------------------------------------------------------------------------------------------------------------------------------------------------------------------------------------------------------------|

FIGURE 4 Port-side view of ICX 7150-48ZP

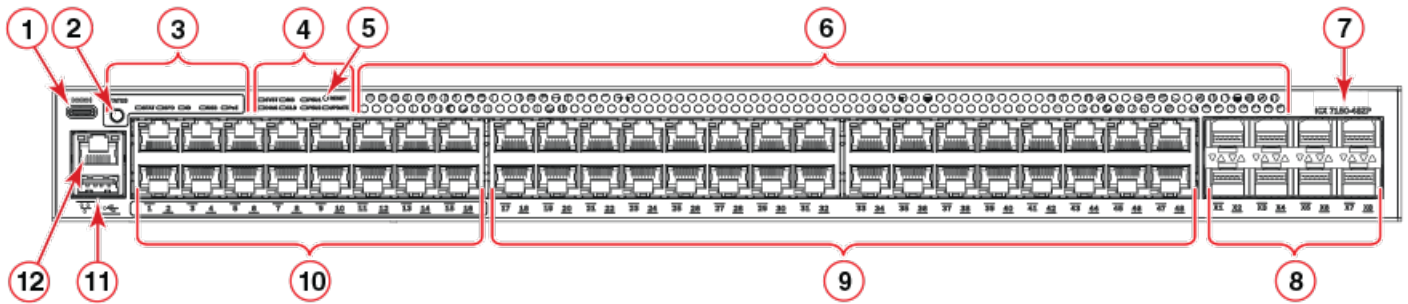

- | | |
|--------------------------------------------------------------------------------------------------------------------------------------------------------------------------------------------------------------------------------------------------------------------------------------------------------------|---------------------------------------------------------------------------------------------------------------------------------------------------------------------------------------------------------------------------------------------------------------------------------------------------------------------------------------------------------------------------------------------------------------------------------------------------------------------------------------------------------------------|
| <ol style="list-style-type: none"> 1. Type-C USB console port 2. Pushbutton to cycle through Mode LEDs 3. Mode LEDs 4. System LEDs 5. Reset Button 6. Venting holes 7. Logo and Model name 8. SFP+ Fiber Stacking/Uplink ports | <ol style="list-style-type: none"> 9. 1G PoE-2 pair user Ports 17 - 48 10. 2.5G PoE-2 pair user Ports 1-16 11. Type-A USB port 12. Out-of-band management port (RJ-45) with 2 LEDs <ol style="list-style-type: none"> a. Left LED - Off: Link-down, Steady green: Link-up, and Blinking green: when there is RX/TX activity b. Right LED - Off: when offline or linked at 10/100Mbps, Blinking green: when there is RX/TX activity |
|--------------------------------------------------------------------------------------------------------------------------------------------------------------------------------------------------------------------------------------------------------------------------------------------------------------|---------------------------------------------------------------------------------------------------------------------------------------------------------------------------------------------------------------------------------------------------------------------------------------------------------------------------------------------------------------------------------------------------------------------------------------------------------------------------------------------------------------------|

Nonport-side view

FIGURE 5 Nonport-side view of ICX 7150-C12P

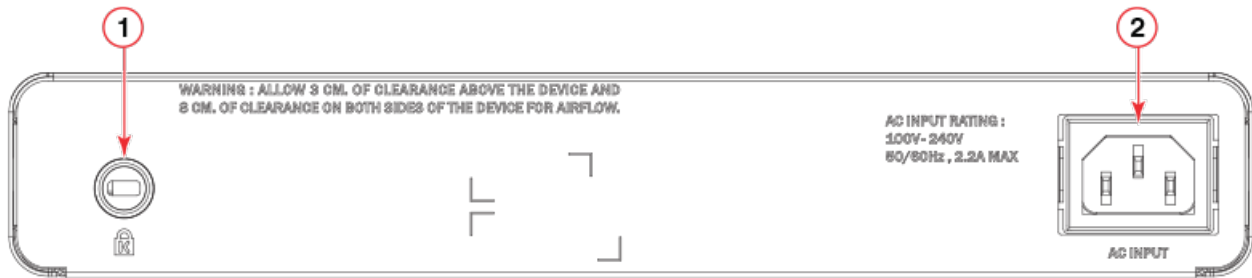

- | | |
|-------------------------------------------------------------------------------|-----------------------------------------------------------------------------|
| <ol style="list-style-type: none"> 1. Kensington security slot | <ol style="list-style-type: none"> 2. AC power supply socket |
|-------------------------------------------------------------------------------|-----------------------------------------------------------------------------|

FIGURE 6 Nonport-side view of ICX 7150-24



- | |
|-----------------------------------------------------------------------------|
| <ol style="list-style-type: none"> 1. AC power supply socket |
|-----------------------------------------------------------------------------|

Device Overview
Nonport-side view

FIGURE 7 Nonport-side view of ICX 7150-48

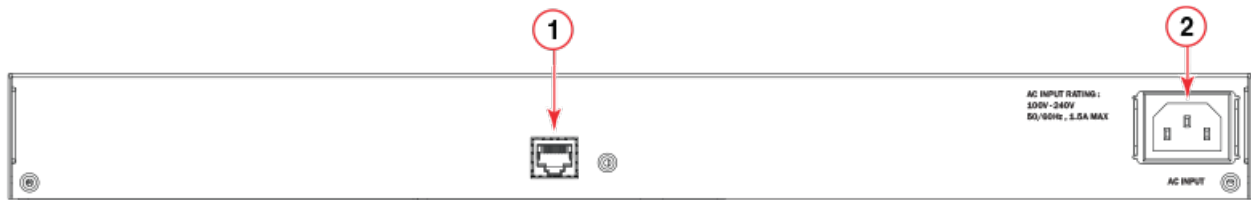

- 1. Management console port - RJ-45
- 2. AC power supply socket

FIGURE 8 Nonport-side view of ICX 7150-24P and ICX 7150-48P

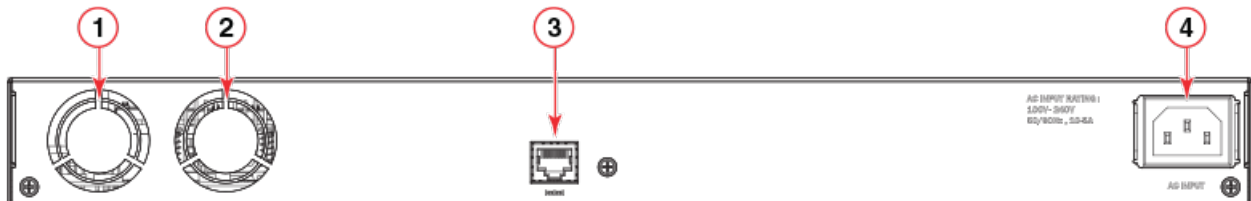

- 1. Fan 1
- 2. Fan 2
- 3. Management console port - RJ-45 (available in the front panel for ICX 7150-24P)
- 4. AC power supply socket

FIGURE 9 Nonport-side view of ICX 7150-48PF

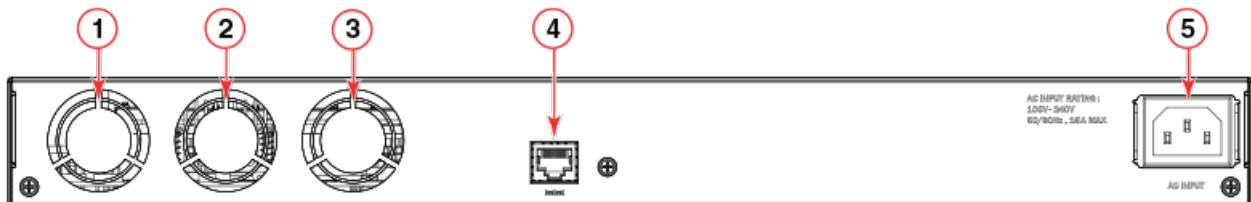

- 1. Fan 1
- 2. Fan 2
- 3. Fan 3
- 4. Management console port - RJ-45
- 5. AC power supply socket

FIGURE 10 Nonport-side view of ICX 7150-48ZP



- 1. Fan 1
- 2. Fan 2
- 3. Management console port - RJ-45
- 4. 920W PSU with 740W of PoE budget
- 5. 920W PSU with 740W of PoE budget

Device management options

You can use the management functions built into the device to monitor the topology, port status, physical status, and other information to help you analyze switch performance and to accelerate system debugging. The device automatically performs power-on self-test (POST) each time it is turned on. Any errors are recorded in the syslog messages.

You can manage the device using any of the management options listed in the following table.

TABLE 8 Management options for the device

Management tool	Out-of-band support	Reference documents
Command line interface (CLI)	Ethernet, serial connection, or USB console	<i>Brocade FastIron Command Reference Guide</i> <i>Feature-based Configuration Guides</i>
Standard SNMP applications	Ethernet or serial connection	<i>Unified IP MIB Reference Guide</i>
Brocade FastIron Web Management Interface	Ethernet or connection via IP address	<i>Brocade FastIron Web Management Interface User Guide</i> NOTE Not all FastIron features are supported via the web management interface.
Brocade Network Advisor (BNA) NOTE BNA must be purchased separately.	Ethernet or serial connection	Brocade Network Advisor documentation set

LRM Adapter support

Some ICX switches do not support Long Reach Module (LRM) optics on 10G fiber ports. LRM adapter can connect to any 10G fiber ports of the ICX switch. It has two 10G fiber ports and both ports can be used at the same time.

The LRM Adapter is supported on all 10G fiber ports for all models of the ICX7150 Family of switches. Below is the front view of the LRM adapter and the SPF+ Optic module with copper pigtail.

FIGURE 11 LRM Adapter front view

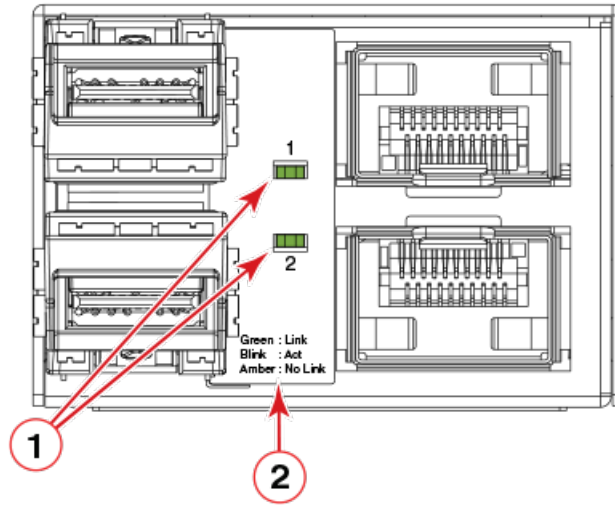

1. Port Status LEDs (see per Port LED status definition below)
 - a. Amber off, Green off : No Power
 - b. Amber on, Green off : Link down
 - c. Amber off, Green on : Link Up
 - d. Amber off, Green Blinking : Link activity
2. Panel Label

FIGURE 12 SPF+ Optic module with copper pigtail



NOTE

The LRM adapter is used to support LRM optics on the ICX7750, ICX7250 and ICX7150 switches. The ICX7450 support LRM optics natively.

Preparing for the Installation

- Safety precautions.....21
- Facility requirements.....23
- Quick installation checklist.....24
- Shipping carton contents.....26

Safety precautions

When using this product, observe all danger, caution, and attention notices in this manual. The safety notices are accompanied by symbols that represent the severity of the safety condition

Refer to Cautions and Danger Notices at the end of this guide for translations of safety notices for this product.

General precautions



DANGER

The procedures in this manual are for qualified service personnel.



DANGER

Before beginning the installation, see the precautions in "Power precautions."



DANGER

The equipment ports are intra-building type and must not be directly connected to metallic outside plant (OSP) cable conductors.



CAUTION

Changes or modifications made to this device that are not expressly approved by the party responsible for compliance could void the user's authority to operate the equipment.



CAUTION

Make sure the airflow around the front, and back of the device is not restricted.



CAUTION

Never leave tools inside the chassis.



CAUTION

To protect the serial port from damage, keep the cover on the port when not in use.



CAUTION

Do not install the device in an environment where the operating ambient temperature might exceed 45°C (113°F).

ESD precautions



DANGER

For safety reasons, the ESD wrist strap should contain a series 1 megaohm resistor.

Preparing for the Installation

Safety precautions



CAUTION

Before plugging a cable into any port, be sure to discharge the voltage stored on the cable by touching the electrical contacts to ground surface.



CAUTION

Static electricity can damage the chassis and other electronic devices. To avoid damage, keep static-sensitive devices in their static-protective packages until you are ready to install them.

NOTE

Wear a wrist grounding strap connected to the chassis ground (if the device is plugged in) or to a bench ground.

Power precautions



DANGER

Make sure that the power source circuits are properly grounded.



DANGER

Make sure you use a power cord displaying the mark of the safety agency that defines the regulations for power cords in your country. The mark is your assurance that the power cord can be used safely with the device.



DANGER

To reduce the risk of electric shock, disconnect all power cords before servicing.



DANGER

Disconnect the power cord from all power sources to completely remove power from the device.



DANGER

To avoid high voltage shock, do not open the device while the power is on.



DANGER

Batteries used for RTC/NVRAM backup are not located in operator-access areas. There is a risk of explosion if a battery is replaced by an incorrect type. Dispose of used components with batteries according to local ordinance and regulations.



CAUTION

Ensure that the device does not overload the power circuits, wiring, and over-current protection. To determine the possibility of overloading the supply circuits, add the ampere (amp) ratings of all devices installed on the same circuit as the device. Compare this total with the rating limit for the circuit. The maximum ampere ratings are usually printed on the devices near the input power connectors.

Lifting and weight-related precautions



DANGER

Use safe lifting practices when moving the product.



DANGER

Mount the devices you install in a rack as low as possible. Place the heaviest device at the bottom and progressively place lighter devices above.



DANGER

Make sure the rack housing the device is adequately secured to prevent it from becoming unstable or falling over.



CAUTION

Do not use the port cover tabs to lift the module. They are not designed to support the weight of the module, which can fall and be damaged.

Laser precautions



DANGER

All fiber-optic interfaces use Class 1 lasers.



DANGER

Use only optical transceivers that are qualified by Brocade Communications Systems, Inc. and comply with the FDA Class 1 radiation performance requirements defined in 21 CFR Subchapter I, and with IEC 60825 and EN60825. Optical products that do not comply with these standards might emit light that is hazardous to the eyes.

Facility requirements

Before installing the device, be sure the following facilities requirements are met.

TABLE 9 Facility requirements

Type	Requirements
General	<ul style="list-style-type: none"> The site should be accessible for installing, cabling, and maintaining the devices. Maintain the operating environment as specified in the Technical Specifications. Allow at least 7.62 cm (3 in.) of space between the front and the back of the device and walls or other obstructions for proper airflow. Allow at least 7.62 cm (3 in.) of space at the front and back of the device for the twisted-pair, fiber-optic, and power cabling. Allow the status LEDs to be clearly visible. Allow for the unit to be connected to a separate grounded power outlet that provides 100 to 240 VAC, 50/60 Hz, within 2 m (6.6 ft) of each device, and is powered from an independent circuit breaker. As with any equipment, a filter or surge suppressor is recommended. Allow for twisted-pair cables to be routed away from power lines, fluorescent lighting fixtures, and other sources of electrical interference, such as radios and transmitters.
Electrical	<ul style="list-style-type: none"> Adequate supply circuit, line fusing, and wire size, as specified by the electrical rating on the switch nameplate Circuit protected by a circuit breaker and grounded in accordance with local electrical codes <p>Refer to the Technical Specifications at the end of this guide for complete power supply specifications.</p>
Thermal	<ul style="list-style-type: none"> A minimum airflow of 39.1 cubic meters/hour (23 cubic ft/min.) available in the immediate vicinity of the switch <p>NOTE Although this airflow may exceed the airflow maximum listed in the device Technical Specifications, the additional airflow is recommended to pressurize the inlet (cool isle) side of rack installations relative to the exhaust side to minimize recirculation of hot air back to the inlet side.</p> <ul style="list-style-type: none"> Ambient air temperature not exceeding 45°C (113°F) while the switch is operating
Rack (when rack-mounted)	<ul style="list-style-type: none"> One rack unit (1U) in a 48.3 cm (19-inch) rack All equipment in the rack grounded through a reliable branch circuit connection

TABLE 9 Facility requirements (continued)

Type	Requirements
	<ul style="list-style-type: none"> • Additional weight of switch not to exceed the rack's weight limits • Temperature: Because the temperature within a rack assembly may be higher than the ambient room temperature, check that the rack-environment temperature is within the specified operating temperature range. • Airflow: Be sure that the airflow direction for all equipment in a rack is the same or consistent. • Mechanical loading: Do not place any equipment on top of a rack-mounted unit. • Rack secured to ensure stability in case of unexpected movement • Circuit overloading: Be sure that the supply circuit to the rack assembly is not overloaded.

Quick installation checklist

The following checklist provides a high-level overview of the basic installation process from the planning stage to the point where the device comes online and is ready to be deployed. Completing all the tasks in the suggested order ensures successful installation. Brocade recommends that you print this checklist and take it to the installation site.

Pre-installation tasks

Review all installation requirements ahead of time as part of your site preparation. Careful planning and site preparation ensures seamless installation, especially when installing multiple devices.

TABLE 10 Installation prerequisites

Task	Task details or additional information	Completed
Unpack the device.	Take an inventory of the hardware components included in your shipment. Refer to Shipping carton contents on page 26.	
Gather necessary components and required tools.	Review the time and items required information at the beginning of each chapter to ensure you have gathered all necessary components required for the following installation tasks: <ul style="list-style-type: none"> • Mounting the Device on page 27. • Installing Transceivers and Cables on page 83. 	
Review the safety precautions.	Refer to Safety precautions on page 21. For translation of these messages, refer to Cautions and Danger Notices on page 115.	
Plan the installation.	Decide whether you want to install the unit on a flat surface or in a rack. For rack installation, obtain the appropriate rack mount kit. Refer to Mounting options on page 27.	
Review and verify installation requirements.	Verify that the following requirements are met. Refer to Facility requirements on page 23. <ul style="list-style-type: none"> • General requirements • Power requirements • Environmental requirements • Clearance for standalone or rack installation 	
Gather network configuration parameters.	<ul style="list-style-type: none"> • IP address: • Subnet mask: • Default gateway: • Time zone: 	

Installation and initial configuration

The initial setup includes mounting the device on a flat surface or in a rack and completing the configuration tasks necessary to bring the device online and verify the operation.

TABLE 11 Installation and basic system configuration

Task	Task details or additional information	Completed
Mount the device.	<p>Choose one of the following mounting options:</p> <ul style="list-style-type: none"> • Mount the device on a desktop or flat surface. Refer to Mounting on a desktop or flat surface on page 28. • Mount the compact device with a magnet. Refer to Mounting the compact device with a magnet on page 30. • Mount the compact device under a fixed surface or desk. Refer to Mounting the compact device under a fixed surface on page 36. • Mount the compact device directly on a wall. Refer to Mounting the compact device directly on a wall on page 39. • Mount the device on a wall using the wall mount brackets. Refer to Mounting on a wall using the wall mount brackets on page 43. • Mount the device on a two-post rack. Refer to Mounting on a two-post rack on page 48. • Mount the device on a universal four-post rack. Refer to Installing the 1U, 1.5U, and 2U Universal Kit for Four Post Racks (XBR-R000295) on page 53. 	
Gather all components required for the initial setup.	Refer to Items required on page 75.	
Provide power to the device.	Refer to Providing power to the device on page 75.	
Attach a management station, establish a console connection, and configure the various levels of passwords.	Refer to Establishing a first-time connection to the console port on page 76. After completing this task, log in to the console port to configure the device.	
Set the IP address, subnet mask, and the default gateway IP address.	Use the ip address command to configure a static device IP address, subnet mask, and gateway IP address, or you can use a DHCP server to obtain the information dynamically. Refer to Configuring an IP address for the device on page 79.	
Set the date and time	<ul style="list-style-type: none"> • Use the clock set command to set the current date and time for the device. Refer to Setting the date and time on page 80 for more information.	
Customize the host name and chassis name.	<ul style="list-style-type: none"> • Use the hostname command to change the default host name and CLI prompt. • Use the chassisname command to change the default chassis name or ID. Refer to Customizing the host name and chassis name on page 79 for more information.	
Establish a connection to the out-of-band management port.	By establishing a connection to the out-of-band management port, you can complete the device configuration using an SSH session, Telnet, or management application, such as Brocade Network Advisor. Refer to Establishing a connection to the out-of-band management port on page 80.	
Verify that the device operates correctly.	<ul style="list-style-type: none"> • Check the LEDs to verify operation of functional parts. Refer to Verifying the correct operation on page 81. • The following commands can be useful to establish an operational baseline for the device. Refer to the <i>Ruckus FastIron Command Reference</i> guide for more information on these commands: <ul style="list-style-type: none"> – show chassis – show version – show cpu – show flash – show files – show run – show boot-preference – show configuration – show running-config – show logging 	
Back up the configuration.	Use the write memory command to replace the startup configuration with the running configuration. Refer to Backing up the running configuration on page 81 for more information.	

Shipping carton contents

When unpacking the device, verify that the contents of the shipping carton is complete. Save the shipping carton and packaging in the event you need to return the shipment.

- The Ruckus ICX 7150 device
- An accessory kit containing the following items:
 - Rack mounting kit containing two L-shaped mounting brackets and two sets of eight sink-head screws (included only with 24-port and 48-port models)
 - Wall mounting kit containing two wall-mount screws and two plastic anchors (included only with ICX 7150-C12P)
 - Two-post rack kit containing four rack-mounting screws and four cage nuts (included only with 24-port and 48-port models)
 - Four rubber feet
 - One AC power cord, shielded (US only)
 - One power cord retainer clip
 - China-RoHS Hazardous/Toxic Substance statement
 - Read Me First document

Mounting the Device

- Mounting options..... 27
- Precautions specific to mounting..... 27
- Mounting on a desktop or flat surface..... 28
- Mounting the compact device with a magnet..... 30
- Mounting the compact device under a fixed surface..... 36
- Mounting the compact device directly on a wall..... 39
- Mounting on a wall using the wall mount brackets..... 43
- Mounting on a two-post rack..... 48
- Installing the 1U, 1.5U, and 2U Universal Kit for Four Post Racks (XBR-R000295)..... 53
- Time and items required..... 54
- Parts list..... 54
- Flush-front mounting the device in the rack..... 55
- Flush-rear (recessed) mounting the device in the rack..... 62

Mounting options

You can install the device in several ways:

- As a standalone unit on a flat surface, for example, a table top. Use the rubber feet included with the shipment to secure the device on the surface. No other equipment is required for desktop installation.
- Only ICX 7150-C12P compact device:
 - As a standalone unit using a magnet (ICX6400-C12-MGNT) on a rack or on any surface that is magnetic such as a metal desk or cabinet.
 - As a standalone unit under a fixed surface, under a desk, or under a shelf using the wall / under desk mount kit (ICX7000-C12-WMK) or two-post rack mount kit (ICX7000-C12-RMK) .
 - As a standalone unit directly on a wall using two screws.
- As a standalone unit on a wall using the wall mounting brackets included with the shipment to secure the device on the wall. No other equipment is required for wall mount installation.
- In a two-post Telco rack: You will need a Universal Two-Post Rack Kit (ICX7000-RMK or ICX7000-C12-RMK) to install in a two-post telecommunications (Telco) rack.
- In a four-post EIA rack: You will need a Universal Four-Post Rack Kit (XBR-R000295) to install devices in EIA racks that are between L-13.7 to 81.28 cm deep (L-5.0 to 32.0 in.), where L is the chassis depth.

Precautions specific to mounting

The following precautions specifically apply to mounting the device.



DANGER

Use safe lifting practices when moving the product.



DANGER

Make sure the rack housing the device is adequately secured to prevent it from becoming unstable or falling over.

Mounting the Device

Mounting on a desktop or flat surface



DANGER

Mount the devices you install in a rack as low as possible. Place the heaviest device at the bottom and progressively place lighter devices above.



DANGER

This equipment is suitable for mounting on concrete or other noncombustible surfaces only.



CAUTION

Make sure the airflow around the front, and back of the device is not restricted.



CAUTION

Never leave tools inside the chassis.



CAUTION

Use the screws specified in the procedure. Using longer screws can damage the device.



CAUTION

The device must be turned off and disconnected from the fabric during this procedure.

Mounting on a desktop or flat surface

Complete the following steps to install the device on a desktop or other flat surface. The device you are installing might look different than the one in the following illustration.

NOTE

The hardware device illustrated in this procedure is only for reference and may not depict the actual device that you are installing.

FIGURE 13 Attaching the adhesive feet on a compact device

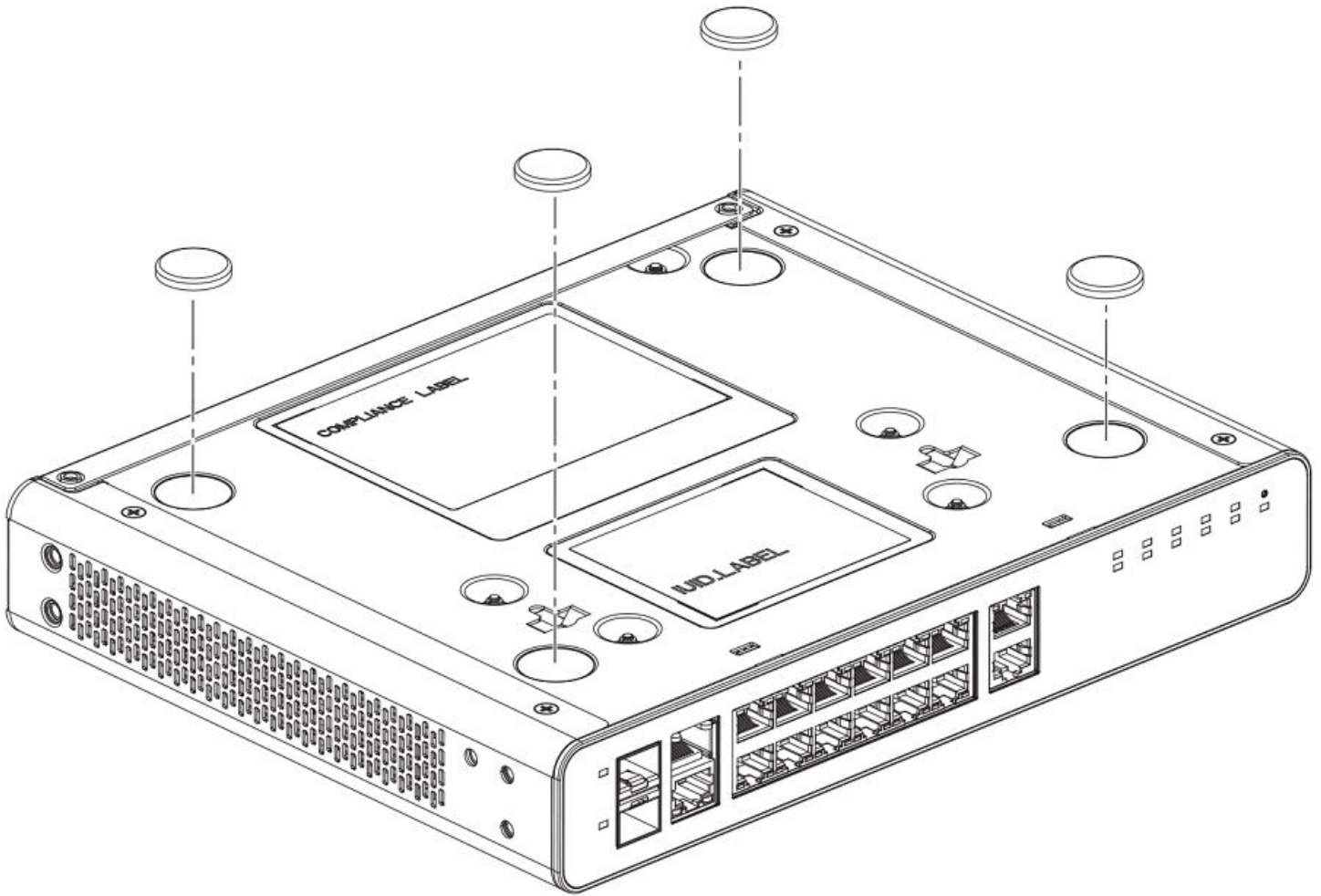

Mounting the Device

Mounting the compact device with a magnet

FIGURE 14 Attaching the adhesive feet on a 24-port or 48-port device

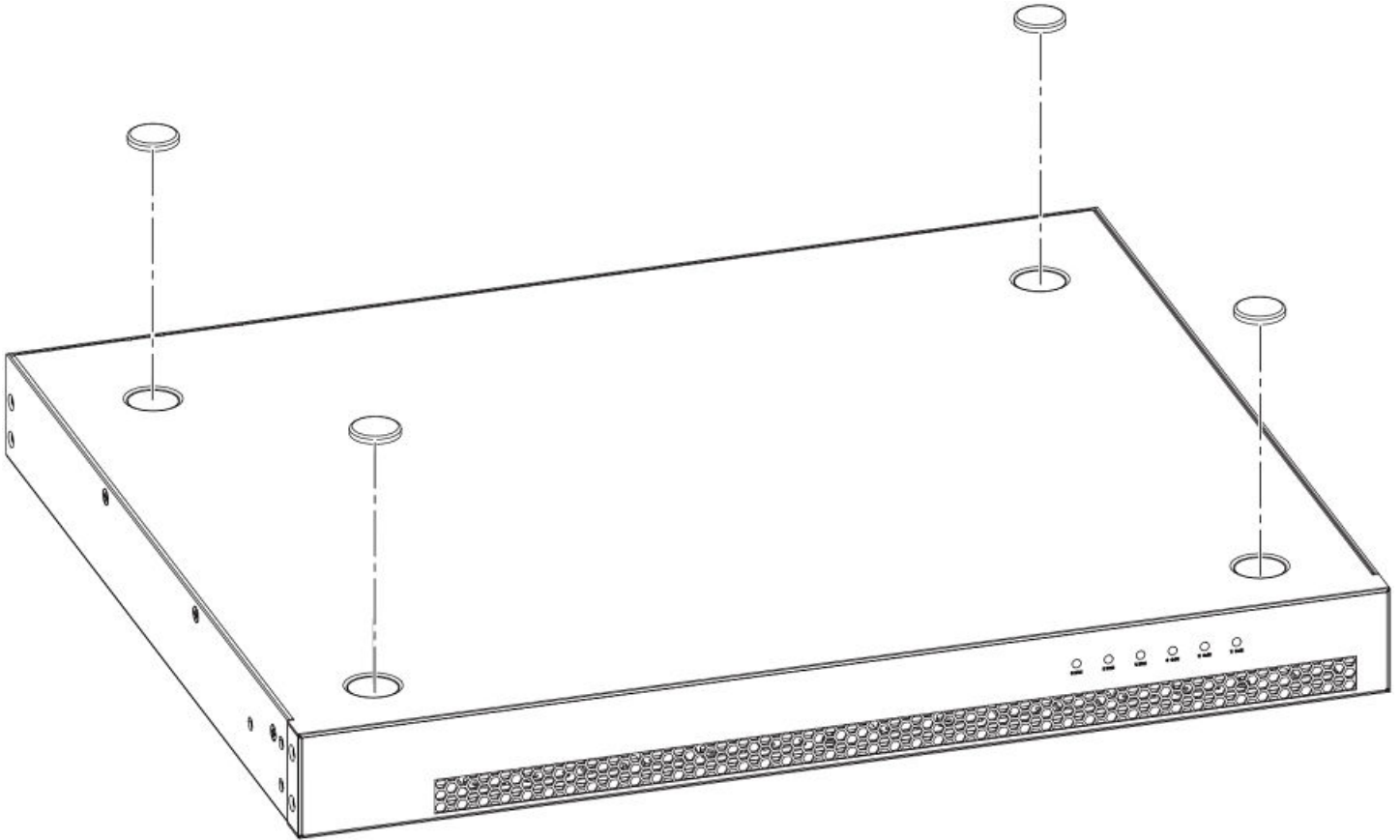

1. Attach the four adhesive feet to the bottom of the device. If installing multiple devices, attach the adhesive feet to each device.
2. Set the device on a flat desktop, table, or shelf near an AC power source. Make sure that adequate ventilation is provided for the system. A 7.62 cm (3 in.) clearance is recommended on each side.
3. If installing multiple devices, place each device squarely on top of the one below. If you have both compact devices and regular devices, place the regular devices at the bottom.
4. Power on the system.

Mounting the compact device with a magnet



CAUTION

Ensure that adequate ventilation is provided for the system. A 3 cm clearance is recommended above the device and 8 cm clearance is recommended on each side.



CAUTION

When magnet mounting a switch, do not install it in a position where it can easily become unstable and fall, causing injury or damage to the switch.

Use the magnet-mount kit to mount the device on a metal wall or a metal surface, including underneath a metal desk. The magnet-mount kit is available for order separately from the device and consists of a single magnet sheet.

Before mounting the device to a metal surface using the magnet sheet, ensure that the following requirements are met:

- The magnet sheet is attached to the bottom panel of the device. Refer to [Attaching the magnet sheet to the device](#) on page 31.
- Ensure that the device is not installed more than 110 mm. above the floor.

Note the following important installation considerations before installing the device on a metal surface using the magnet mount:

- The strength of the magnet will vary depending on the surface it is used on.
- The magnet's force might weaken over time. Check the strength of the magnet regularly for about one year. Move the device up and down and confirm the magnet strength.

When adequate ventilation is provided and the magnet is attached to the device, you can securely mount the device in the following locations:

- A metal wall or metal surface. Refer to [Mounting the device on a metal surface or metal wall](#) on page 32.
- Underneath a metal desktop. Refer to [Mounting the device under a metal desk](#) on page 34.

Attaching the magnet sheet to the device

Before mounting the device to a metal surface, place the logo side of the magnet sheet (displaying the Brocade logo) squarely against the bottom panel of the device to attach the device to the magnet sheet.



CAUTION

The magnet sheet can only be placed against the bottom panel of the device. Do not attempt to attach the magnet sheet to any other panels on the device.



CAUTION

Before mounting the device using the magnet sheet, make sure the rubber feet are not installed on the device to ensure that the magnet sheet holds on to the device strongly and does not detach. If the rubber feet are already installed, remove them first before attaching the magnet sheet.

Mounting the Device

Mounting the compact device with a magnet

FIGURE 15 Attaching the logo side of the magnet sheet to the bottom panel of the compact device

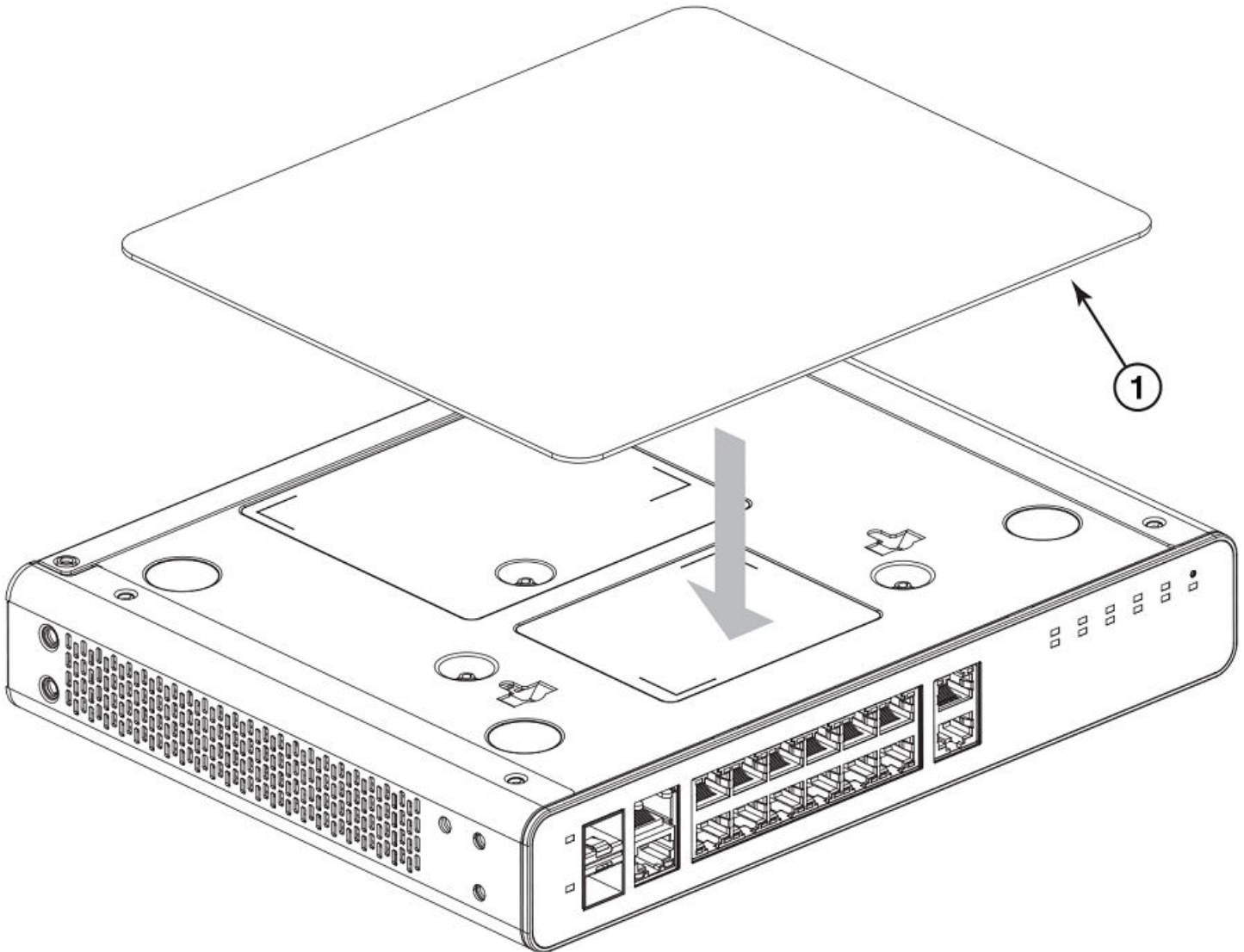

Mounting the device on a metal surface or metal wall



CAUTION

Do not mount the device on a surface with the top panel facing downward. Mount the device only on a vertical metal surface with the front panel port-side facing downward.



CAUTION

Ensure that the metal surface is flat and the texture is smooth to hold the device strongly. Check for other conditions that might impede secure magnetic mount.

Complete the following steps to securely mount a compact device on a metal surface or metal wall:

1. Ensure that the magnet sheet is attached to the bottom panel of the device. Refer to [Attaching the magnet sheet to the device](#) on page 31.

2. Place the magnet sheet (with the logo side now attached to the bottom panel of the device) against the metal surface or metal wall.

FIGURE 16 Mounting a compact device to a metal surface using the magnet mount

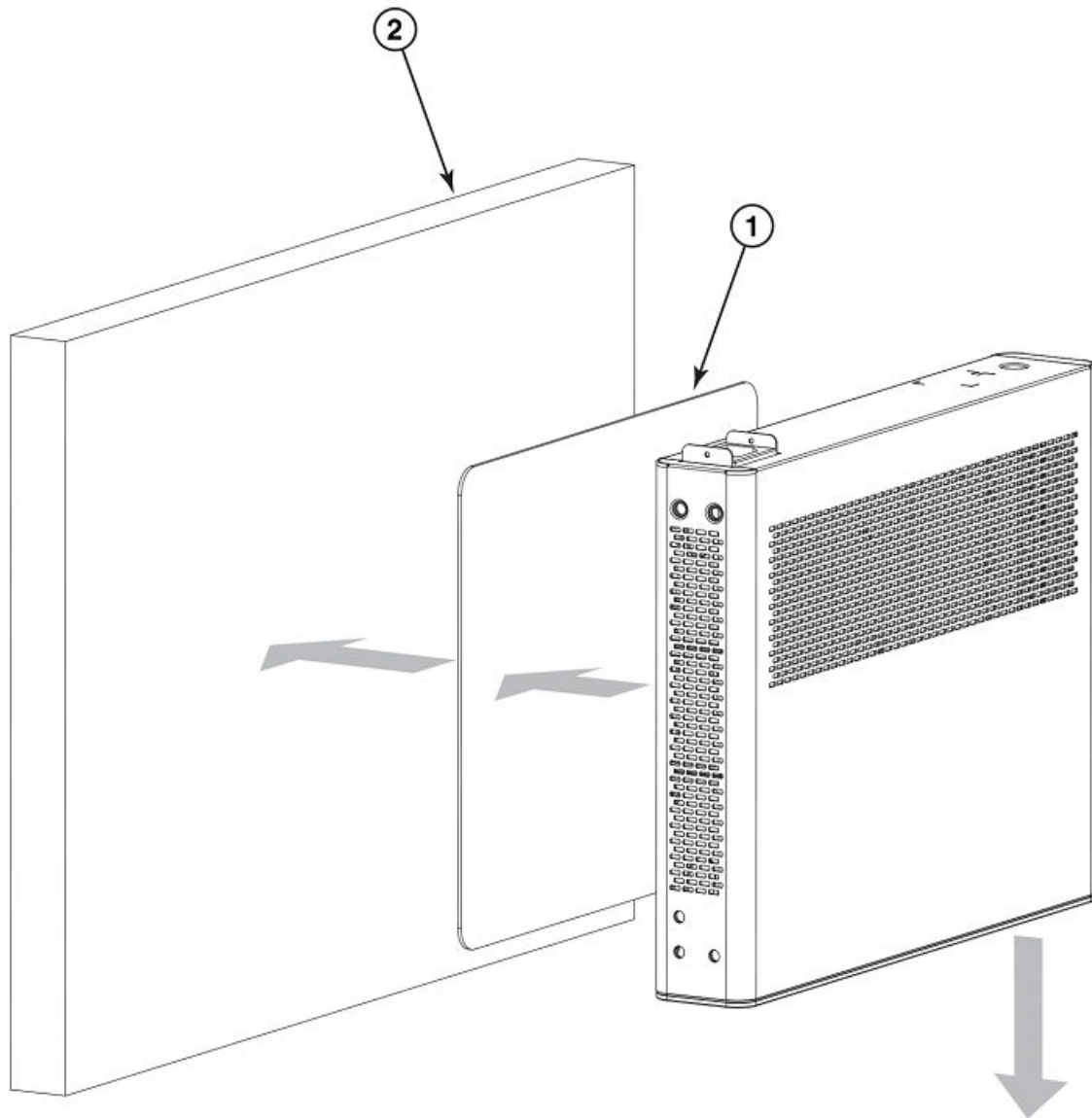

Mounting the Device

Mounting the compact device with a magnet

FIGURE 17 A compact device mounted on a metal surface with ports down

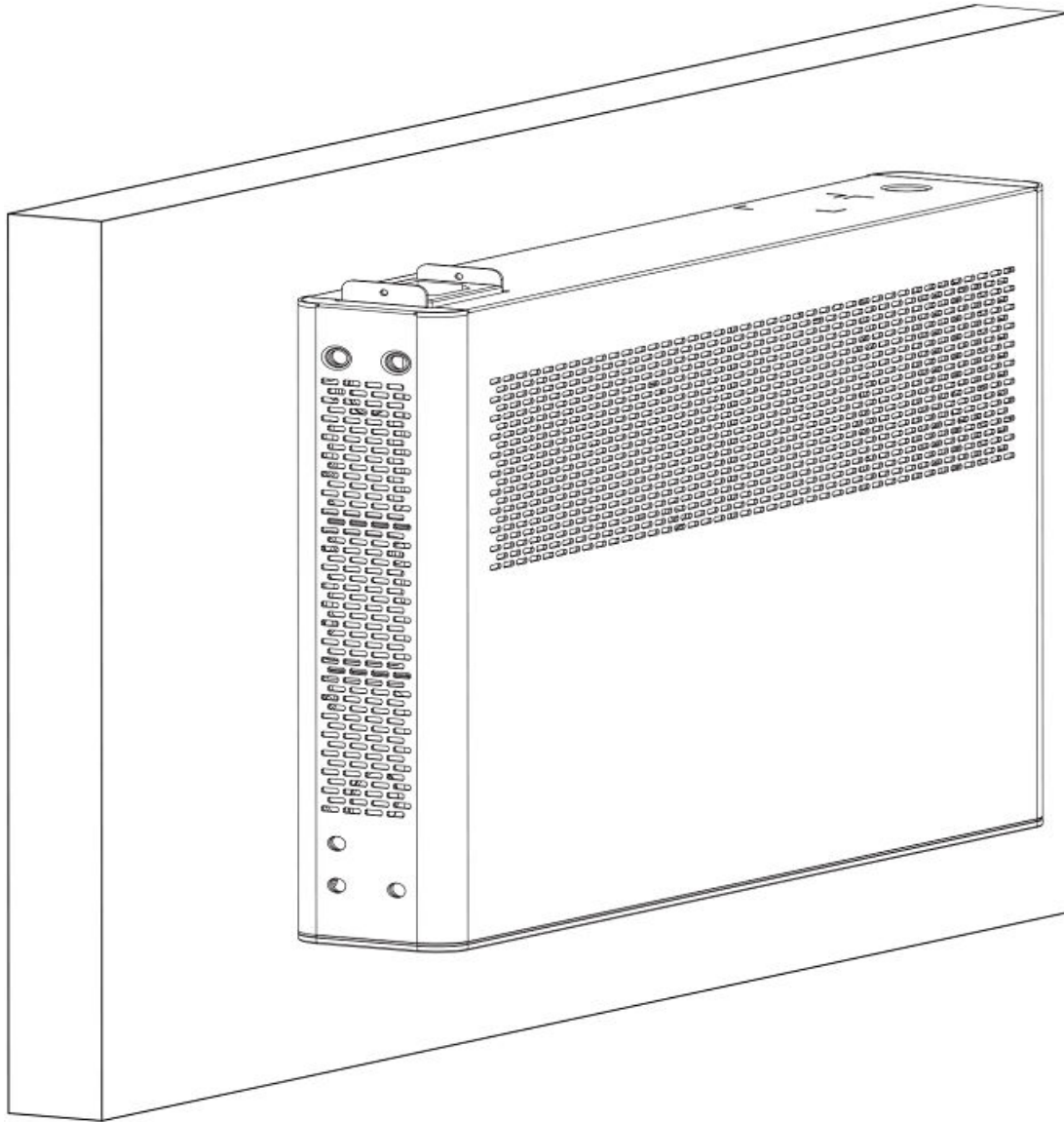

Mounting the device under a metal desk

NOTE

Do not mount the device directly underneath a desktop surface with the top panel facing downward. Mount the device only on the vertical metal surface of the desk with the front panel ports side facing downward.

Complete the following steps to securely mount a compact device under a metal desktop:

1. Ensure that the magnet sheet is attached to the bottom panel of the device. Refer to [Attaching the magnet sheet to the device](#) on page 31.

2. Place the bottom panel of the device with the magnet sheet attached under the metal desk, against the side of the device. Ensure that the front panel (port side) of the device is facing downward.

FIGURE 18 Mounting a compact device underneath a metal desktop using the magnet mount

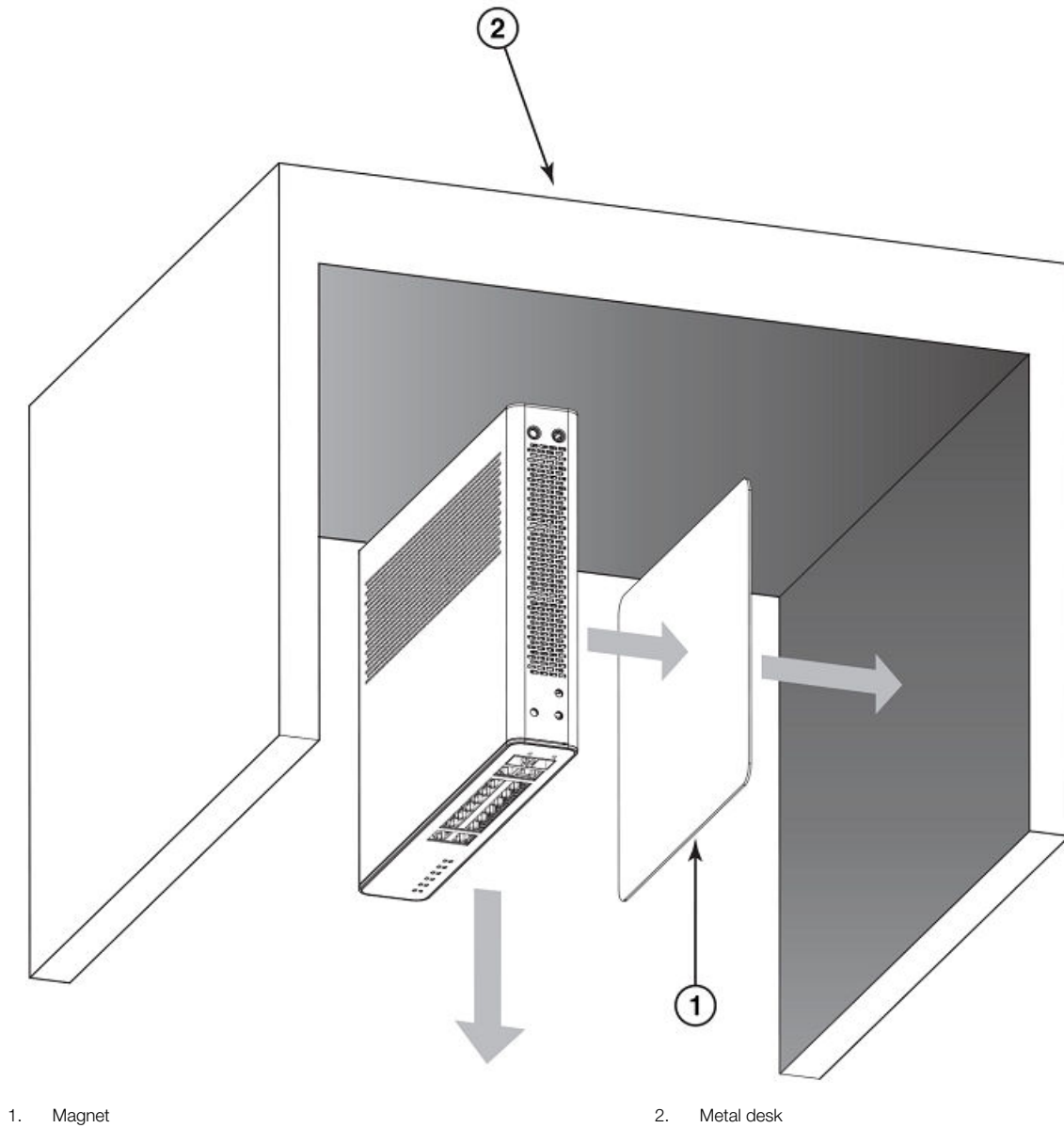

Mounting the Device

Mounting the compact device under a fixed surface

FIGURE 19 A compact device securely mounted underneath a metal desk with the port side facing down

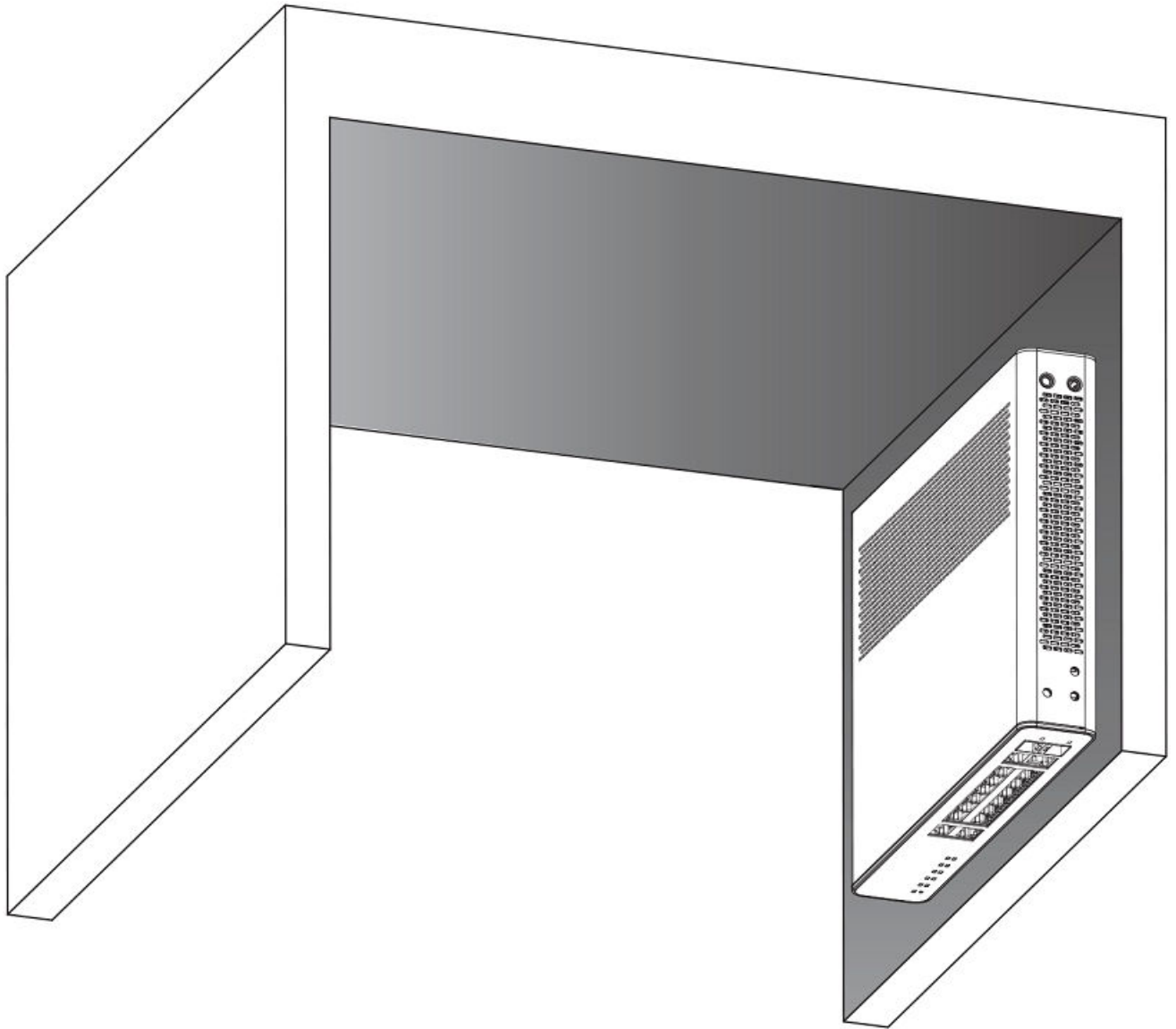

Mounting the compact device under a fixed surface

Use the following items to mount the device under a fixed surface such as under a desk, or under a shelf.

- #2 Phillips screwdriver
- Hammer
- Drill
- Mounting anchors
- Wall / under desk mount kit (ICX7000-C12-WMK - short brackets) or two-post rack mount kit (ICX7000-C12-RMK - long brackets)
- Mounting screws



DANGER

When mounting the device under a fixed surface, under a desk, or under a shelf, mount the device with the bottom panel down and in a place where there is not much foot traffic. The fixed surface must be strong enough to withstand the weight of the device such that the device or the surface does not fall down.



CAUTION

When mounting the device under a fixed surface, under a desk, or under a shelf, use the long brackets to provide adequate ventilation and not exceed the operating temperature.



CAUTION

Do not install the device in an environment where the operating ambient temperature might exceed 35°C (95°F).

Mounting the Device

Mounting the compact device under a fixed surface

Complete the following steps to mount the device under a fixed surface.

1. Using a Phillips screwdriver, attach the mounting brackets to the diagonally opposite sides of the device using two #6-32 sink-head screws on each side.

FIGURE 20 Mounting a compact device under a fixed surface with short brackets (ICX7000-C12-WMK)

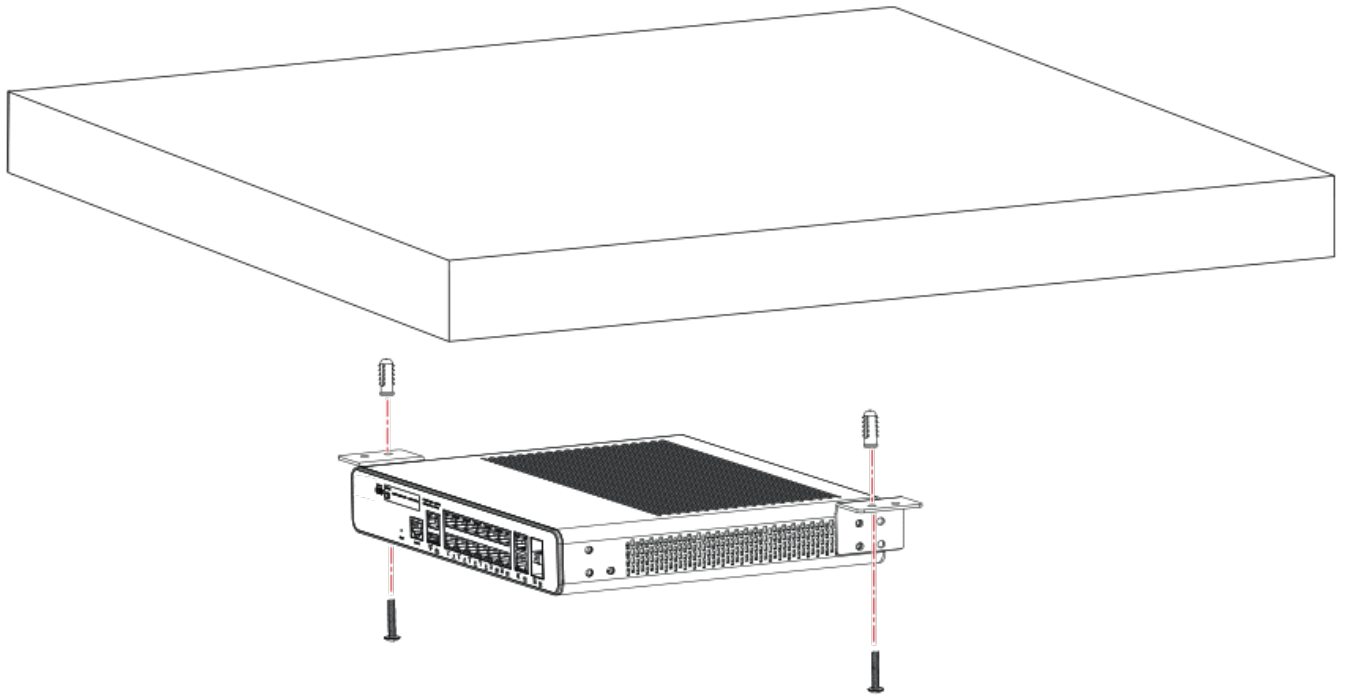
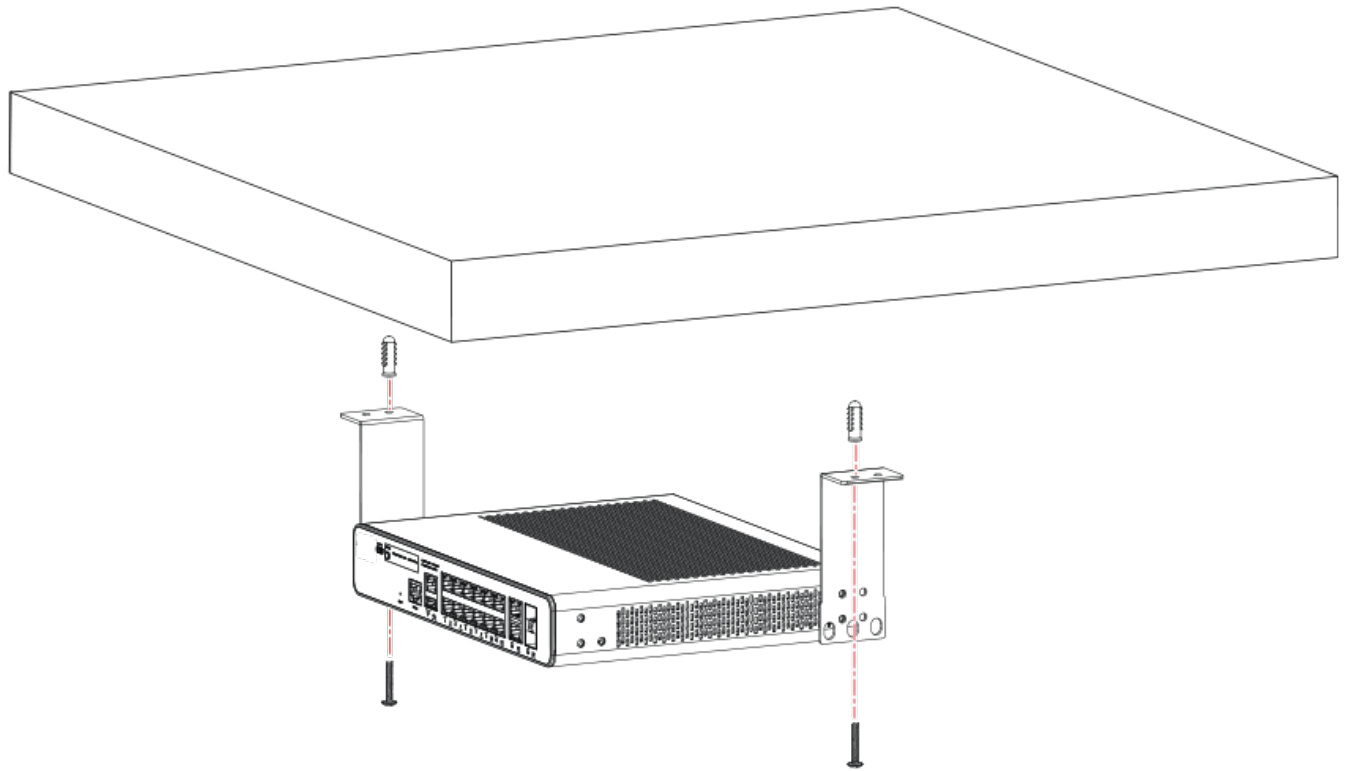

FIGURE 21 Mounting a compact device under a fixed surface with long brackets (ICX7000-C12-RMK)



2. Drill two holes under the fixed surface or desk where you want to mount the device.
3. Hammer the mounting anchors into the two holes.
4. With the bottom panel of the device facing down, use the #2 Phillips screwdriver to secure the two mounting screws into the mounting anchors.

Mounting the compact device directly on a wall

Use the following items to wall mount the device directly to a wall:

- #2 Phillips screwdriver
- Hammer
- Drill
- Wall mount anchors
- Wall mount screws
- Wall Mount Holes Location template
- Tape

NOTE

When mounting the device on a wall, mount the device with the port side down.

Mounting the Device

Mounting the compact device directly on a wall

Complete the following steps to mount the device directly to a wall.

1. Use tape to place the Wall Mount Holes Location template against the wall, in the same position that you plan to place the device against the wall. The Wall Mount Holes Location template serves as a guide to drilling the screws and wall-mount anchors into the correct location on the wall in order to place the device in the desired location.
2. Using the Wall Mount Holes Location template as a guide, drill two holes in the wall where you want to mount the device.
3. Hammer the wall-mount anchors into the two holes.

4. Use the #2 Phillips screwdriver to secure the two wall-mount screws into the wall-mount anchors. Leave a gap of 4.0 to 4.5 mm between the screw head and the wall.

FIGURE 22 Preparing to wall mount the device

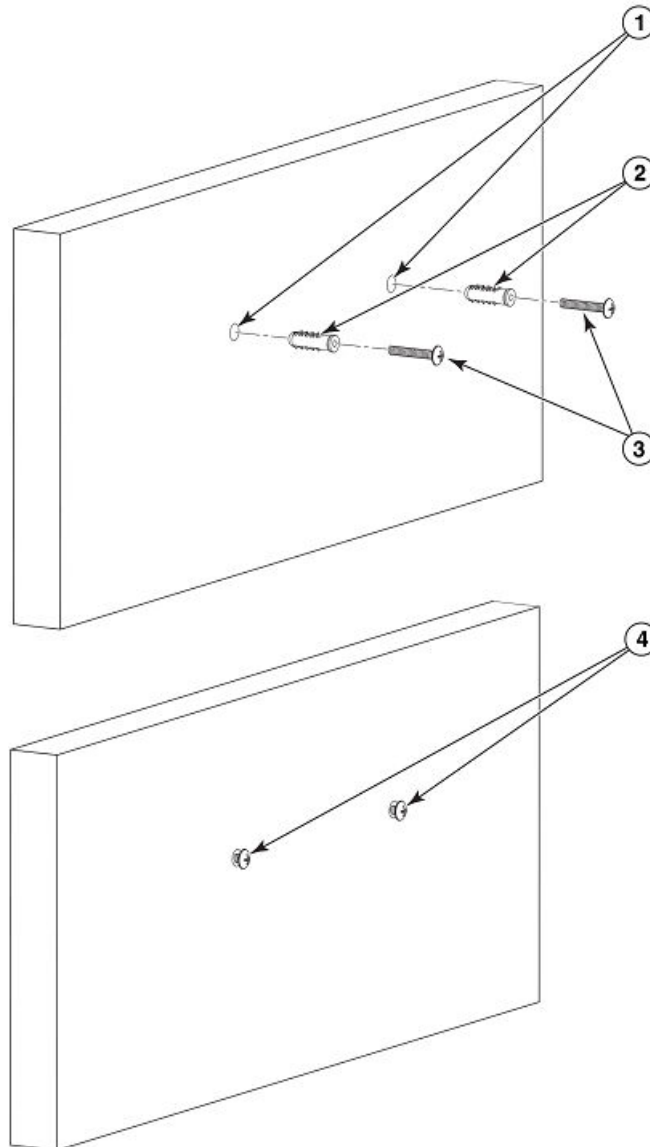

1. Drilled holes in wall
2. Wall-mount anchors
3. Wall-mount screws
4. 4.0-4.5 mm space between screw head and wall

Mounting the Device

Mounting the compact device directly on a wall

5. With the port side of the device facing down, aim the mounting holes on the bottom panel of the device towards the wall-mounting screws on the wall and hang the device securely against the wall, so that the wall-mount screws are inserted into the mounting holes.

FIGURE 23 Wall mounting a compact device - View of rear panel

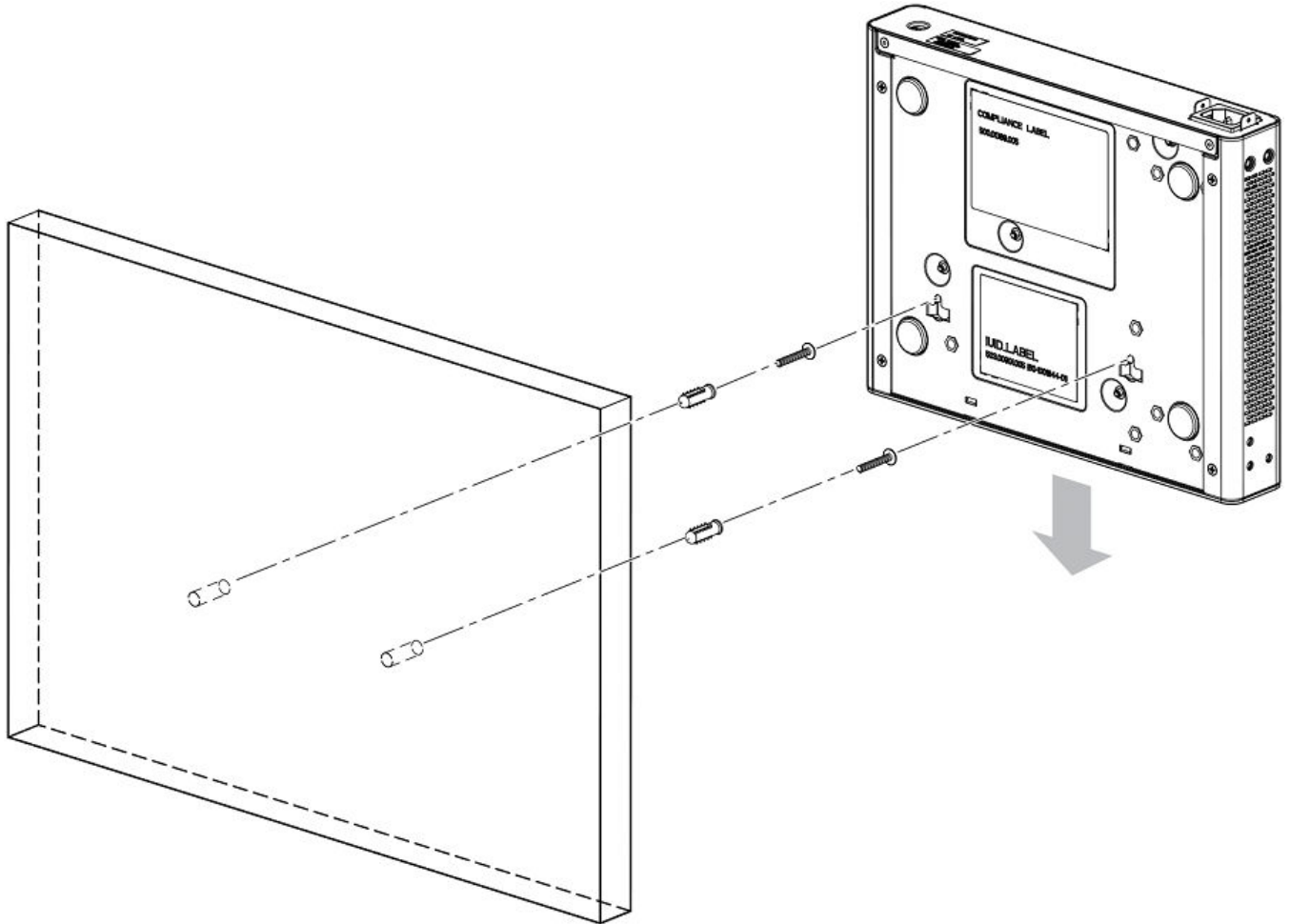
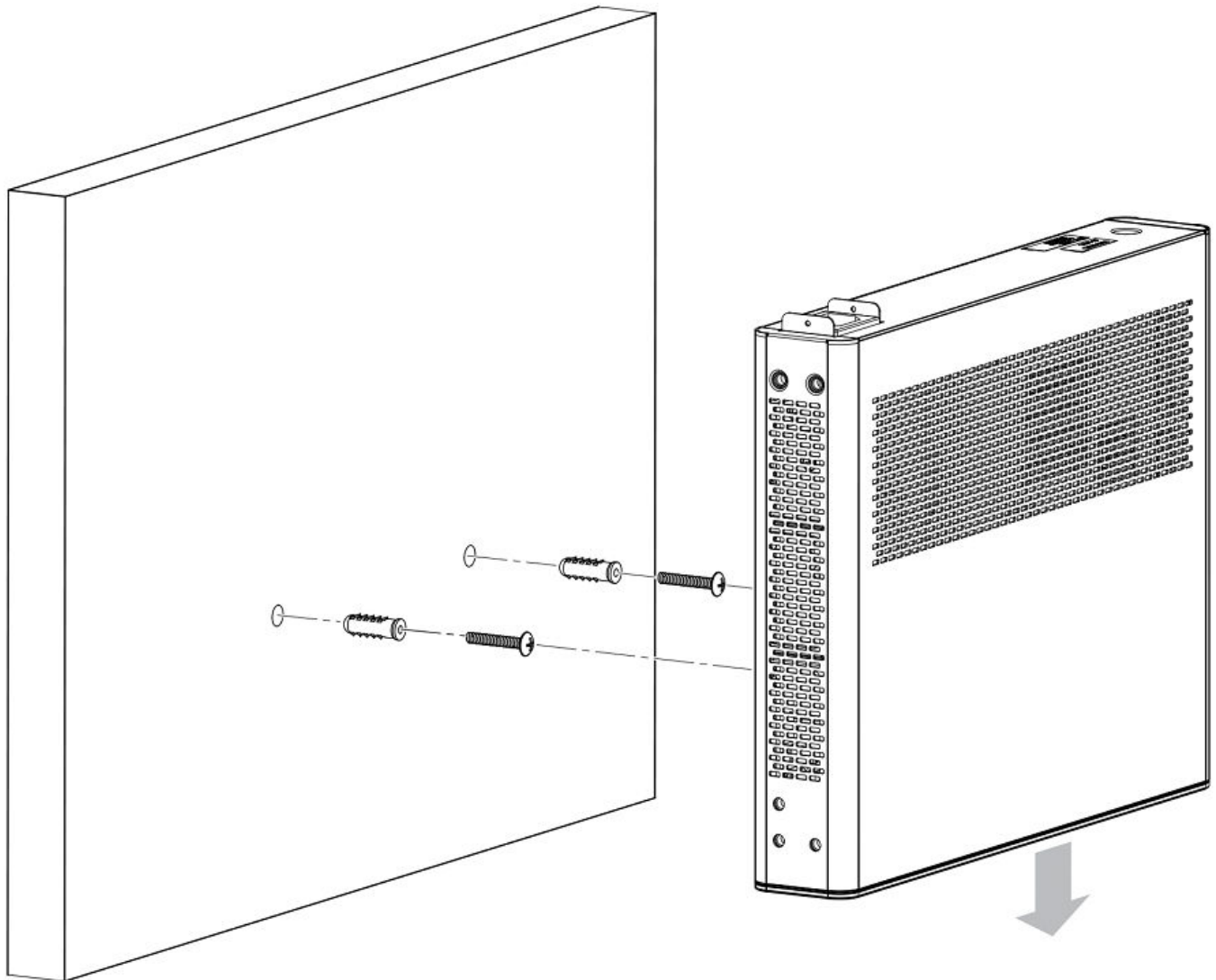

FIGURE 24 Wall mounting a compact device - View of the top panel



Mounting on a wall using the wall mount brackets

NOTE

You need a #2 Phillips screwdriver, a hammer, and a drill for wall mount installation.

NOTE

Mount the devices that have fans such that there is enough space for ventilation on the air-intake and air-exhaust sides to maintain the ambient operating temperature.



DANGER

This equipment is suitable for mounting on concrete or other noncombustible surfaces only.

Mounting the Device

Mounting on a wall using the wall mount brackets

NOTE

The hardware device illustrated in this procedure is only for reference and may not depict the actual device that you are installing.

Complete the following steps to mount the device to a wall.

1. Attach the four adhesive feet to the bottom of the device.

- Using a Phillips screwdriver, attach the wall mount brackets to the sides of the device using four #6-32 sink-head screws on each side.

FIGURE 25 Attaching the wall mount brackets to a 24-port device

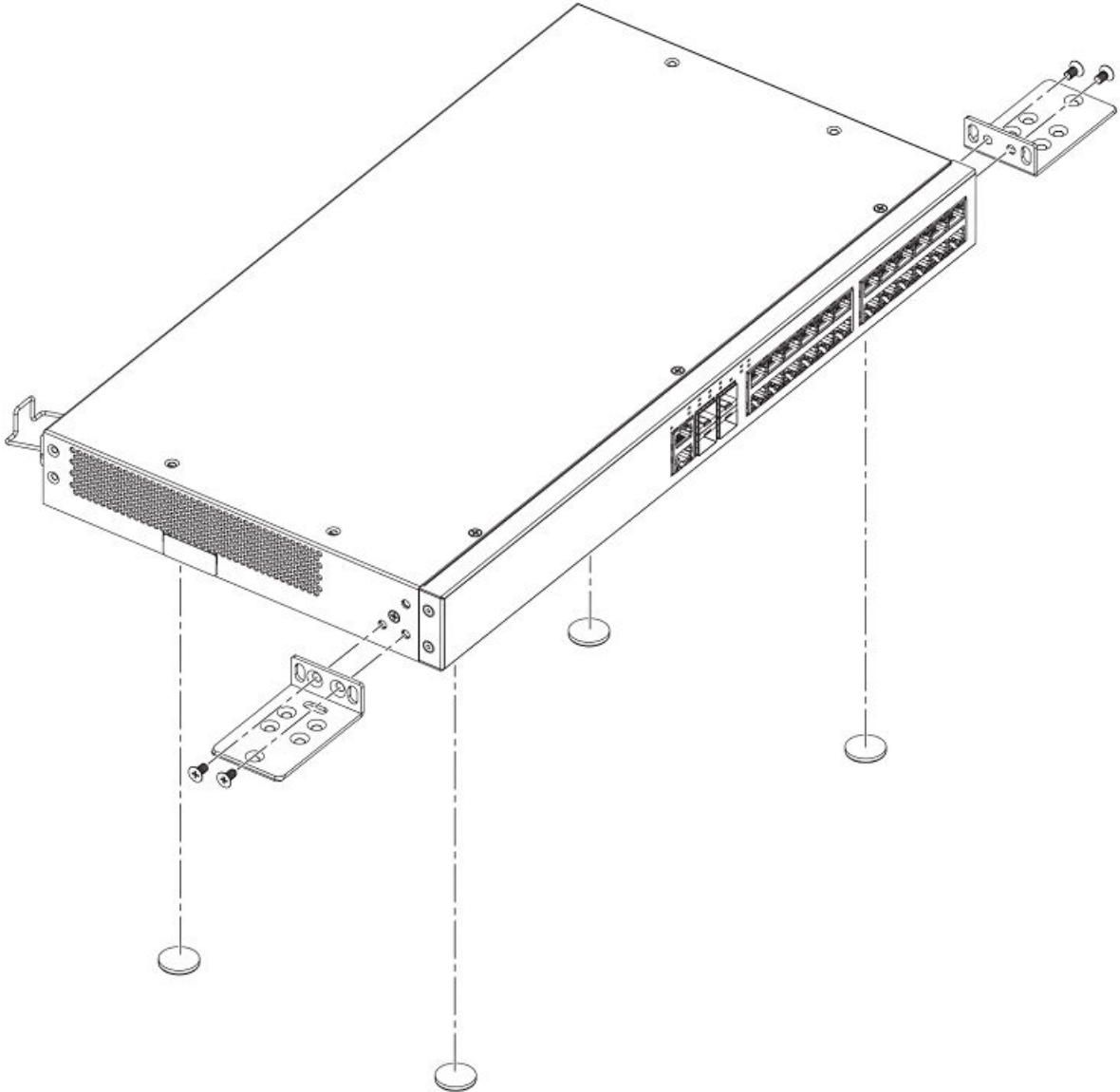

Mounting the Device

Mounting on a wall using the wall mount brackets

FIGURE 26 Attaching the wall mount brackets to a 48-port device

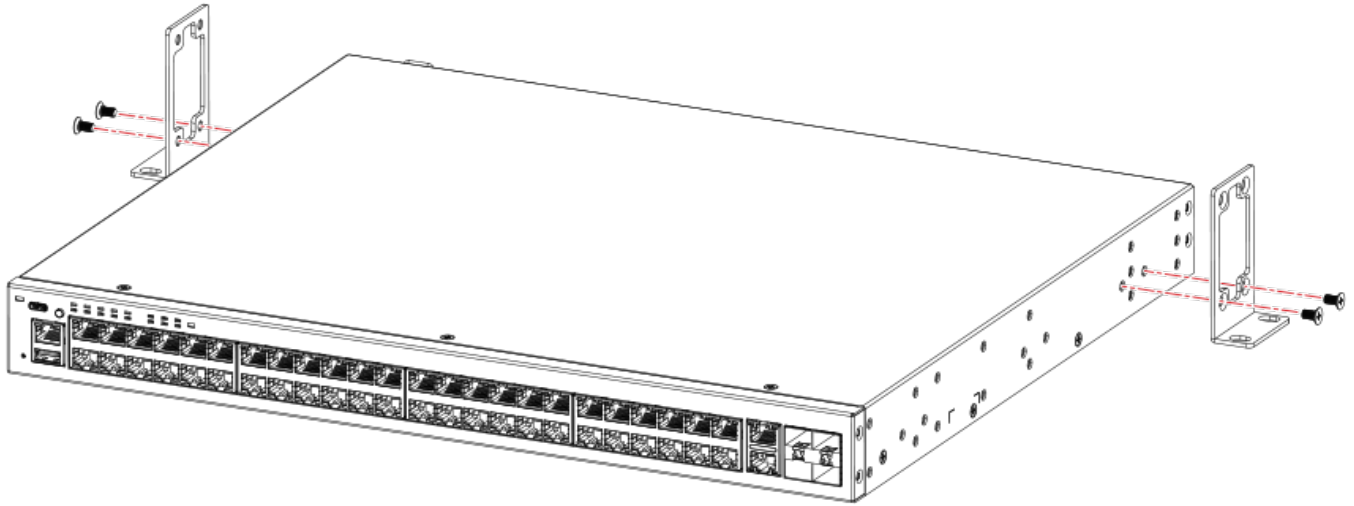

3. Drill two holes on the wall where you want to mount the device.
4. Hammer two wall mount anchors into the holes on the wall.

5. Use the two wall mount screws to fasten the device to the wall mount anchors.

FIGURE 27 Wall mounting a 24-port device with port-side up

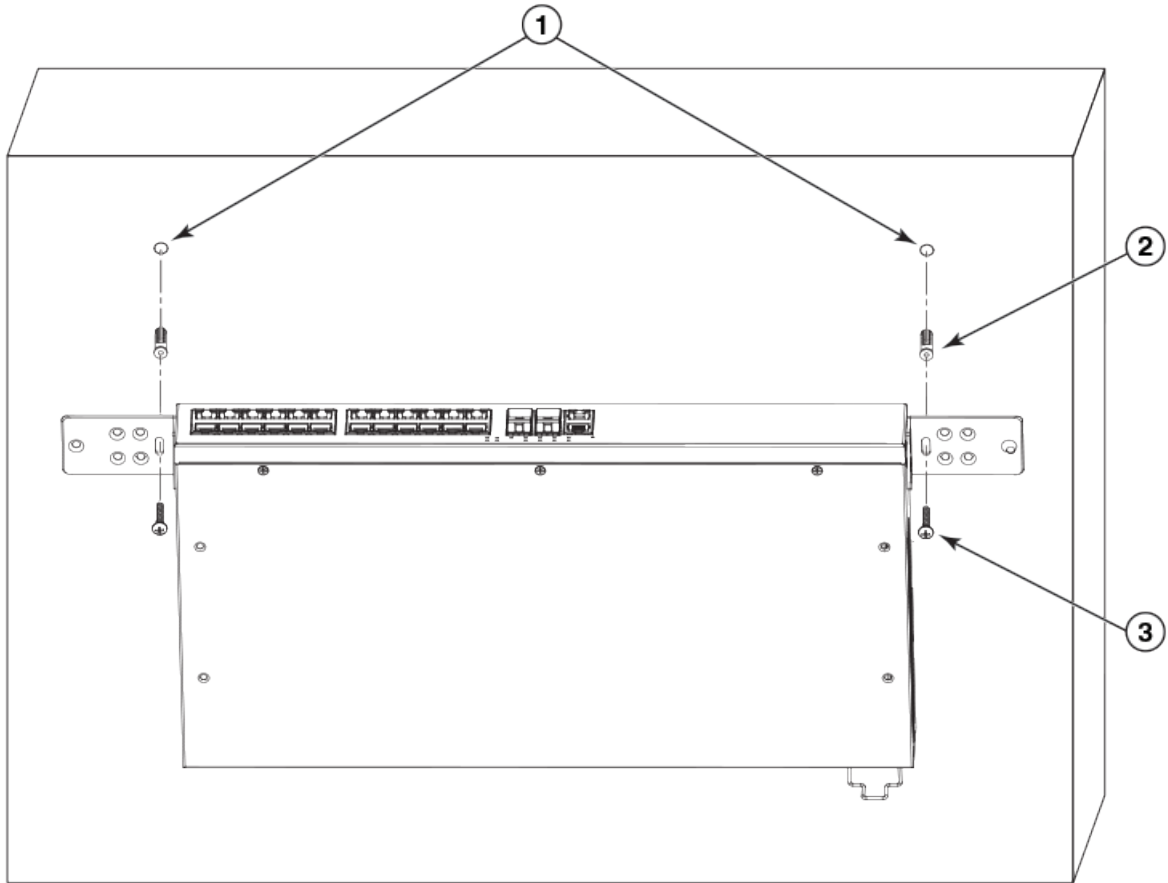

1. Drilled holes
2. Wall mount anchors
3. Wall mount screws

Mounting the Device
Mounting on a two-post rack

FIGURE 28 Wall mounting a 48-port device with port-side down

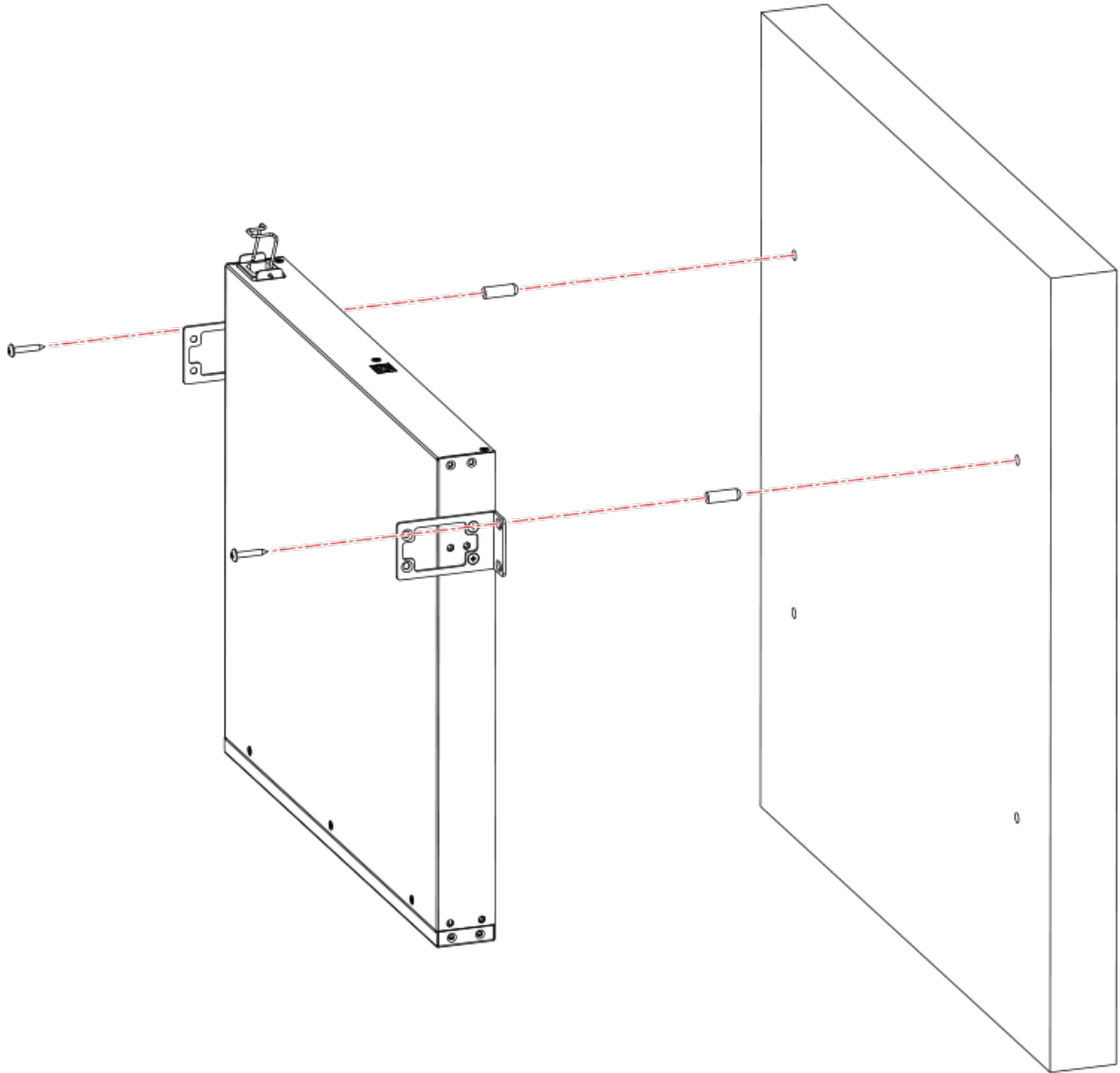

NOTE

Brocade recommends that you install the 24P, 48P, and 48PF models with the port-side down to maintain the ambient temperature.

Mounting on a two-post rack

The devices use stationary mounting when mounted in a rack.



DANGER

Make sure the rack housing the device is adequately secured to prevent it from becoming unstable or falling over.



CAUTION

Ensure that adequate ventilation and airflow is provided for the system. A 4.5 cm (1.77 in) clearance is recommended above and below the device and 8 cm (3.15 in) clearance is recommended on each side.

NOTE

You need a #2 Phillips screwdriver for rack mount installation.

NOTE

The ICX 7150-C12P compact device requires the ICX7000-C12-RMK rack mount kit which is optionally orderable.

Complete the following steps to mount devices in a rack.

1. Remove the rack mounting kit from the shipping carton. The kit contains two L-shaped mounting brackets and six sink-head screws.

Mounting the Device

Mounting on a two-post rack

- Using a Phillips screwdriver, attach the mounting brackets to the sides of the device using six sink-head screws.

FIGURE 29 Attaching the mounting brackets for a compact device

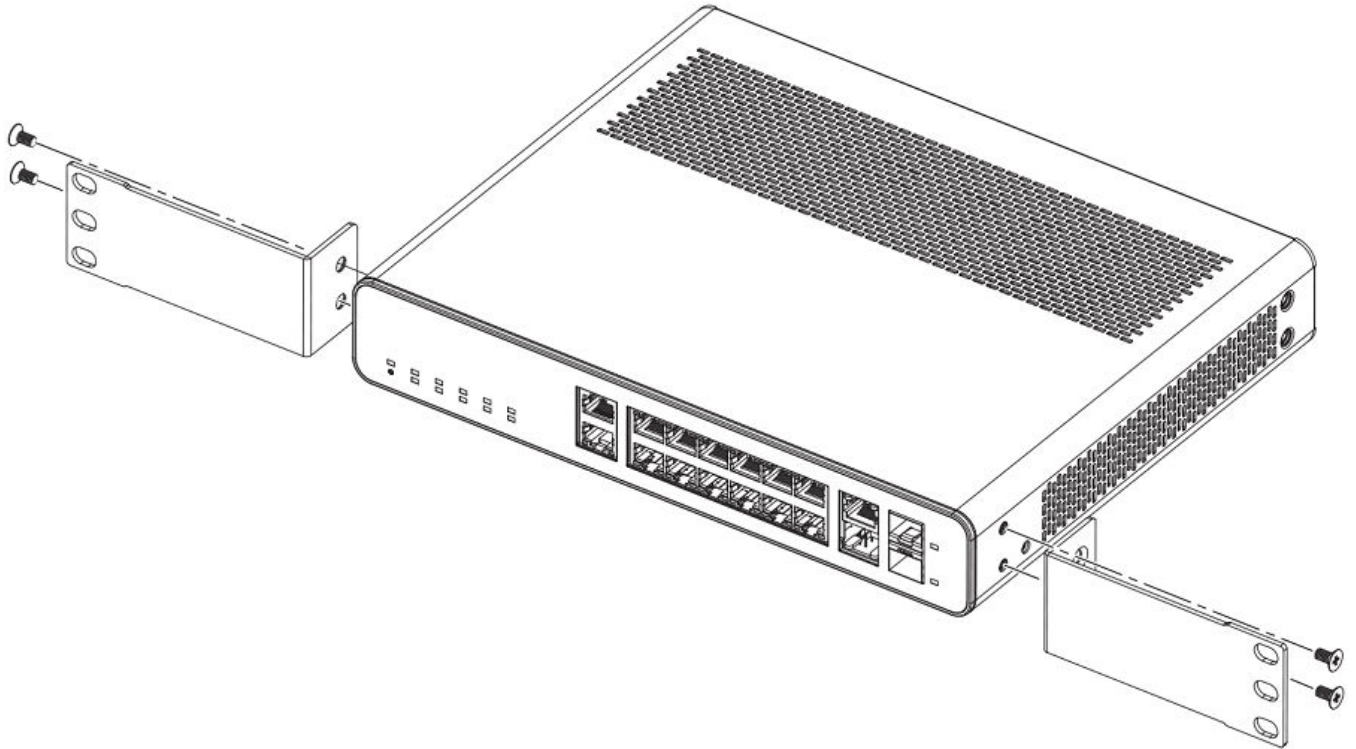
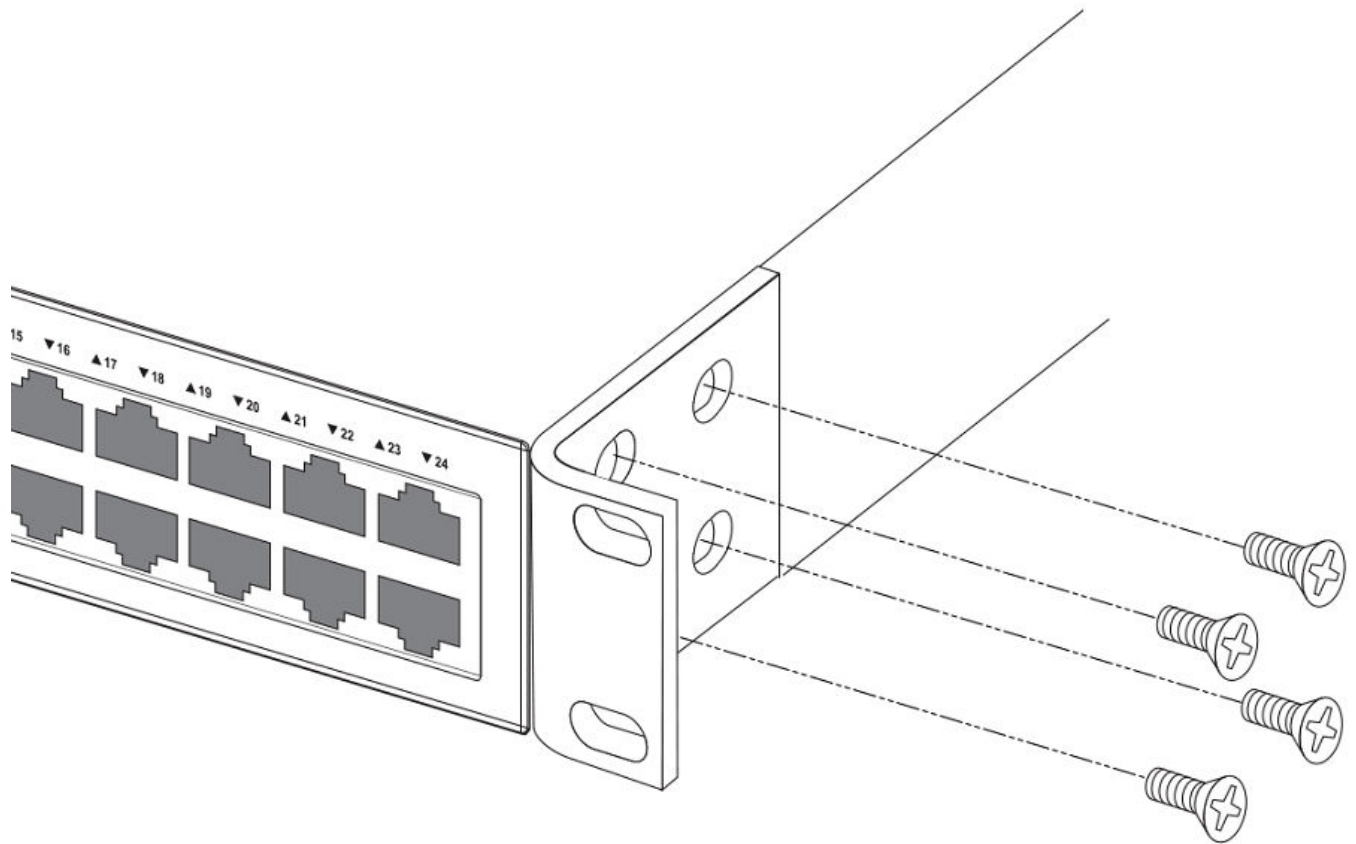

FIGURE 30 Attaching the rack mounting brackets for 24-port and 48-port devices



3. Remove the two-post rack kit from the shipping carton. The kit contains four rack-mounting screws and four cage nuts.
4. Insert the cage nuts in the two-post rack where you want to mount the device.

Mounting the Device

Mounting on a two-post rack

- Using a Phillips screwdriver, mount the device in a two-post rack using four rack-mounting screws.

FIGURE 31 Installing a compact device in a two-post rack

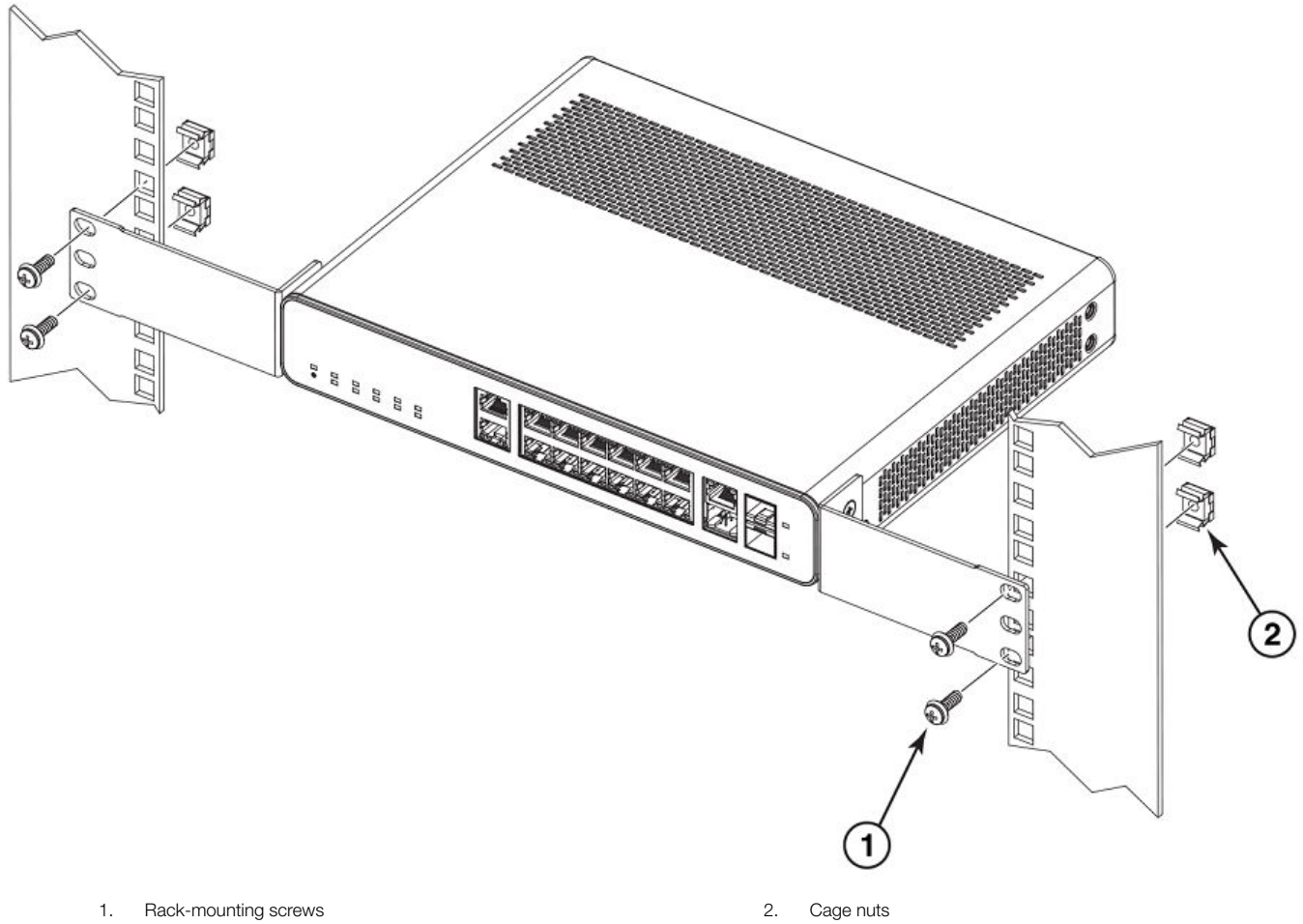
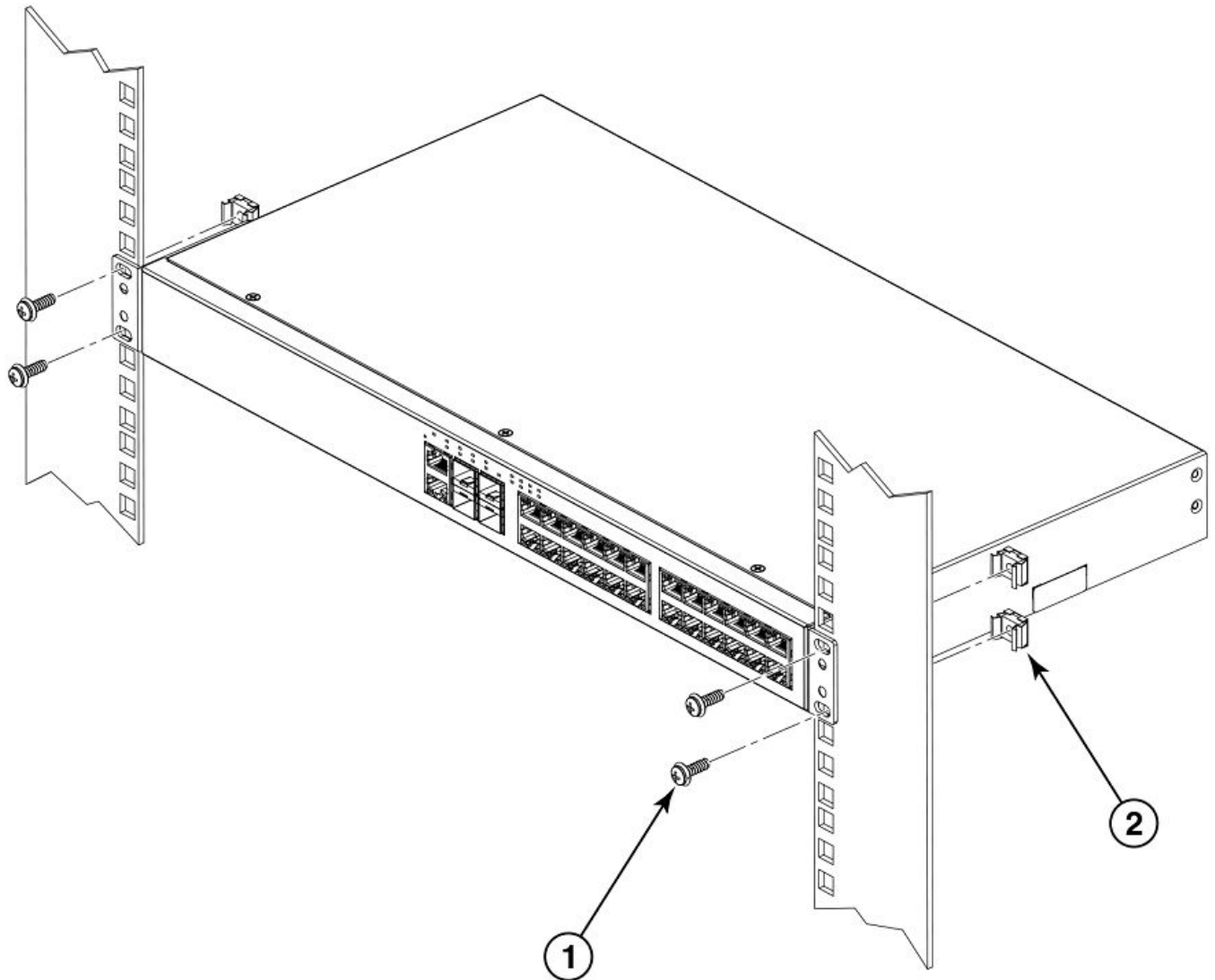

FIGURE 32 Installing a 24-port or 48-port device in a two-post rack

1. Rack-mounting screws
2. Cage nuts
6. If installing multiple devices, mount them in the rack, one below the other with the heaviest device at the bottom and lightest device on the top.

Installing the 1U, 1.5U, and 2U Universal Kit for Four Post Racks (XBR-R000295)

Use the following instructions to install a 1U, 1.5U, or 2U device in a 19-in. (48.3 cm) EIA rack using the 1U, 1.5U, and 2U Universal Kit for Four Post Racks (XBR-R000295). Any updates to these instructions will be added to the hardware installation guide for your product.

Mounting the Device

Time and items required

The device can be installed so that the port side is either flush with the front posts or recessed with the non-port side flush with the rear posts. A recessed position allows a more gradual bend in the fiber-optic cables connected to the device and less interference in the aisle at the front of the rack.

NOTE

Hardware devices illustrated in these procedures are only for reference and may not depict the device you are installing into the rack.

Time and items required

Allow 15 to 30 minutes to complete this procedure. Note the following requirements to ensure correct installation and operation.

The following items are required to install the device using the 1U, 1.5U, and 2U Universal Kit for Four-Post Racks:

- #2 Phillips torque screwdriver
- 1/4-inch slotted-blade torque screwdriver

Parts list

The following parts are provided with the 1U, 1.5U, and 2U Universal Kit for Four Post Racks Installation (XBR-R000295).

FIGURE 33 Rack kit parts

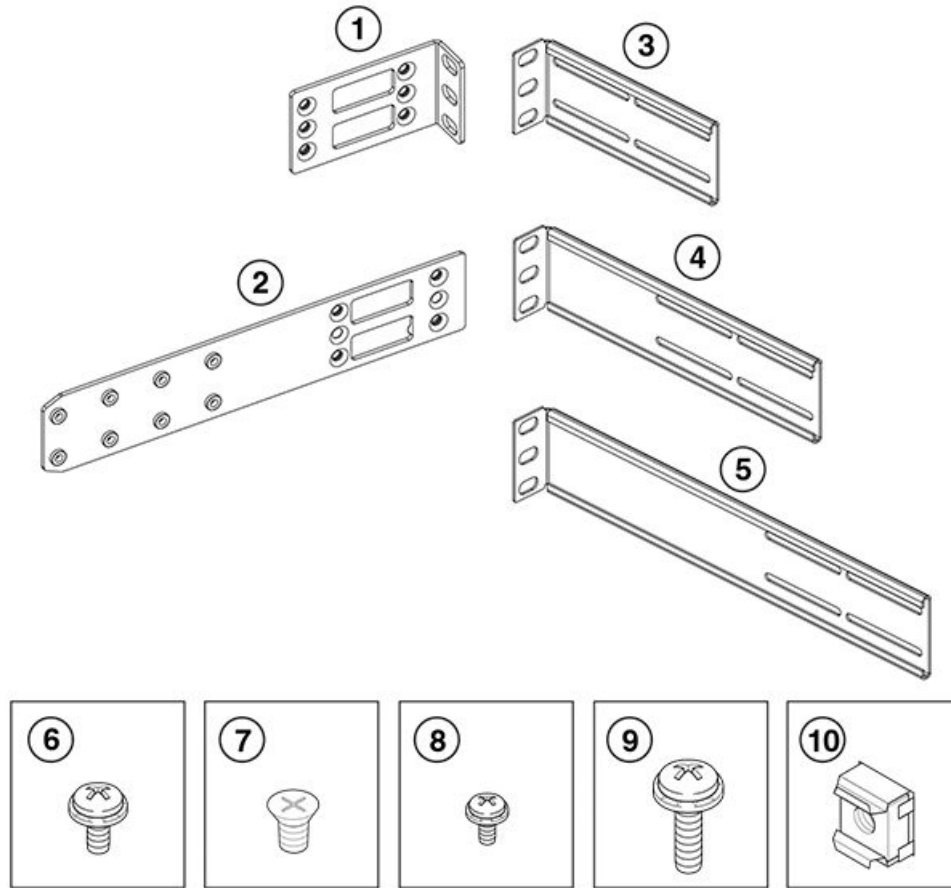

- | | |
|---------------------------------------------------------------------------------------------------------------------------------------------------------------------------------------------------------------------------|--------------------------------------------------------------------------------------------------------------------------------------------------------------------------------------------------------------------------------------------------------------------------------------------------------------------|
| <ul style="list-style-type: none"> 1. Front brackets (2) 2. Bracket extensions (2) 3. Rear brackets, short (2) 4. Rear brackets, medium (2) 5. Rear brackets, long (2) | <ul style="list-style-type: none"> 6. Screw, 8-32 x 5/16-in., panhead Phillips (8) 7. Screw, 8-32 x 5/16-in., flathead Phillips (16) 8. Screw, 6-32 x 1/4-in., panhead Phillips (8) 9. Screw, 10-32 x 5/8-in., panhead Phillips (8) 10. Retainer nut, 10-32 (8) |
|---------------------------------------------------------------------------------------------------------------------------------------------------------------------------------------------------------------------------|--------------------------------------------------------------------------------------------------------------------------------------------------------------------------------------------------------------------------------------------------------------------------------------------------------------------|

Ensure that the items listed and illustrated are included in the kit. Note that not all parts may be used with certain installations depending on the device type.



CAUTION
Use the screws specified in the procedure. Using longer screws can damage the device.

Flush-front mounting the device in the rack



CAUTION
The device must be turned off and disconnected from the fabric during this procedure.

NOTE

Illustrations in these rack installation procedures are for reference only and may not show the actual device that you are installing.

Mounting the Device

Flush-front mounting the device in the rack

Complete the following tasks to install the device in a four-post rack:

1. [Attaching the front brackets](#) on page 56
2. [Attaching the bracket extensions to the device](#) on page 57
3. [Installing the device in the rack](#) on page 58
4. [Attaching the rear brackets to the extensions](#) on page 59
5. [Attaching the rear brackets to the rack posts](#) on page 61

Attaching the front brackets

Complete the following steps to attach the front brackets to the device.

1. Position the right front bracket with the flat side against the right side of the device at the front of the device, as shown in [Figure 34](#).
2. Insert four 8-32 x 5/16-in. flathead screws through the vertically aligned holes in the bracket and then into the holes on the side of the device. Use the upper and lower screw holes, leaving the center holes empty.
3. Repeat [Step 1](#) and [Step 2](#) to attach the left front bracket to the left side of the device.

4. Tighten all the 8-32 x 5/16-in. screws to a torque of 15 in-lb (17 cm-kg).

FIGURE 34 Attaching the front brackets

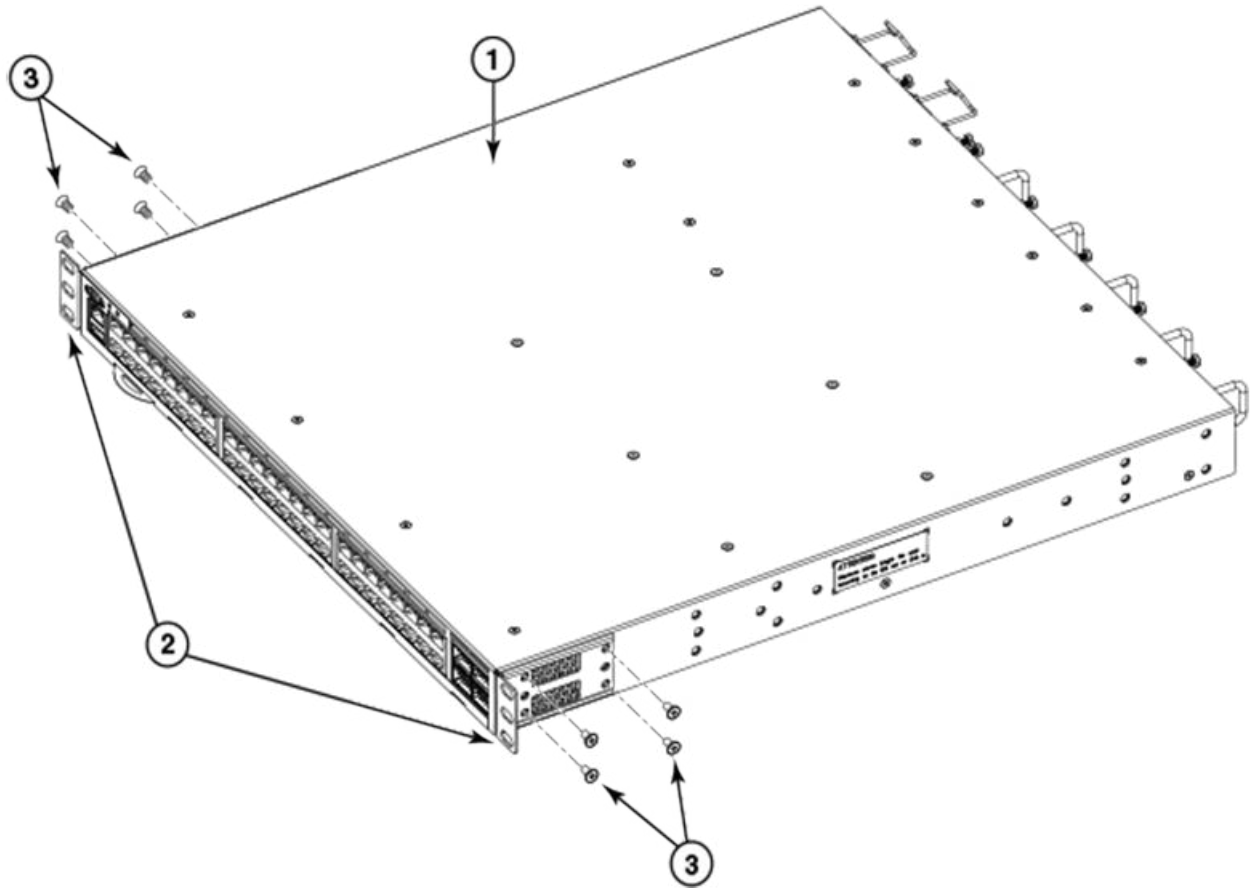

1. Brocade device
2. Front brackets
3. Screws, 8-32 x 5/16-in., flathead Phillips

Attaching the bracket extensions to the device

Complete the following steps to attach the extension brackets to the device.

1. Position the right bracket extension along the side of the device as shown in [Figure 35](#).
2. Insert four 8-32 x 5/16-in. flathead screws through the vertically aligned holes in the bracket extension and then into the holes on the side of the device. Use the upper and lower screw holes, leaving the center holes empty.
3. Repeat step 1 and step 2 to attach the left bracket extension to the left side of the device.

Mounting the Device

Flush-front mounting the device in the rack

4. Tighten all the 8-32 x 5/16-in. screws to a torque of 15 in-lb (17 cm-kg).

FIGURE 35 Attaching the bracket extensions to the device

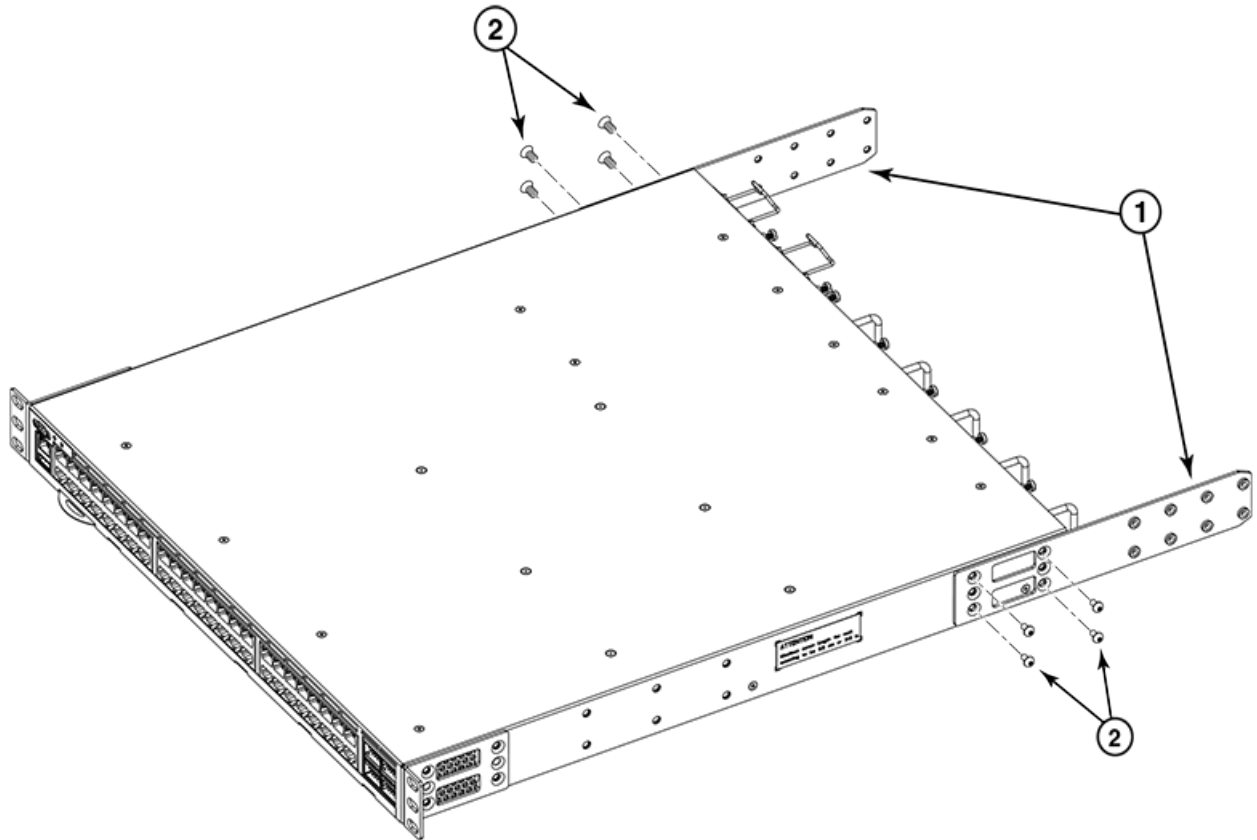

1. Bracket extensions

2. Screws, 8-32 x 5/16-in., flathead Phillips

Installing the device in the rack

Complete the following steps to install the device in the rack.

1. Position the device in the rack, as shown in [Figure 36](#), providing temporary support under the device until the rail kit is secured to the rack.
2. Attach the right front bracket to the right front rack post using two 10-32 x 5/8-in. panhead screws and two retainer nuts. Use the upper and lower holes in the bracket.
3. Attach the left front bracket to the left front rack post using two 10-32 x 5/8-in. panhead screws and two retainer nuts. Use the upper and lower holes in the bracket.

4. Tighten all the 10-32 x 5/8-in. screws to a torque of 25 in-lb (29 cm-kg).

FIGURE 36 Positioning the device in the rack

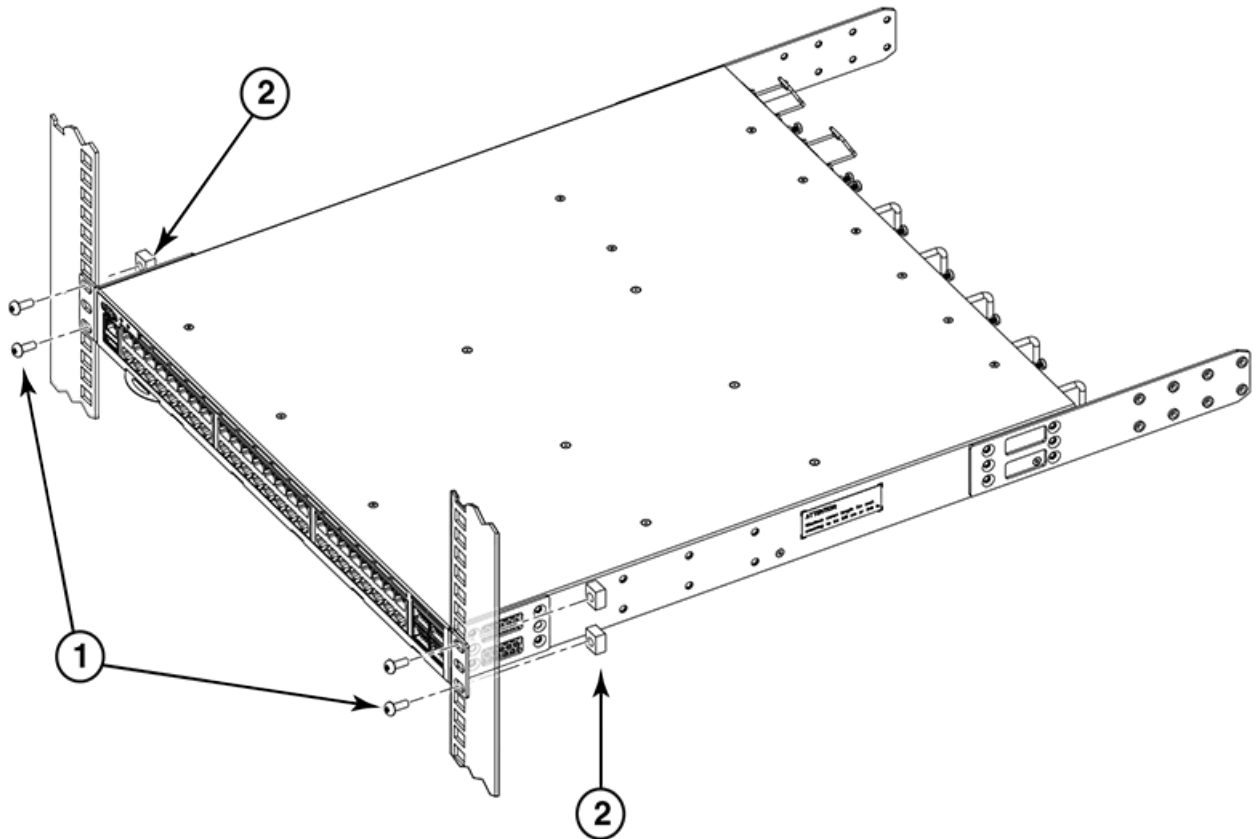

1. Screws, 10-32 x 5/8-in., panhead Phillips

2. Retainer nuts, 10-32

Attaching the rear brackets to the extensions

Complete the following steps to attach the rear brackets to the extensions. There are short, medium, and long rear brackets that you can use for this step. Choose the correct bracket for the depth of your rack.

1. Select the proper length rear bracket for your rack depth.
2. Slide the right rear bracket onto the right extension, as shown in [Figure 37](#).
The short rear brackets are shown. Use the first and third vertical pairs of holes for the screws.
Refer to [Figure 38](#) for the positioning of the medium or long brackets and screws.
3. Attach the brackets using four 6-32 x 1/4-in. panhead screws.
4. Repeat [Step 2](#) and [Step 3](#) to attach the left rear bracket to the left extension.

Mounting the Device

Flush-front mounting the device in the rack

- Adjust the brackets to the rack depth and tighten all the 6-32 x 1/4-in. screws to a torque of 9 in-lb (10 cm-kg).

FIGURE 37 Attaching the short rear brackets to the extensions

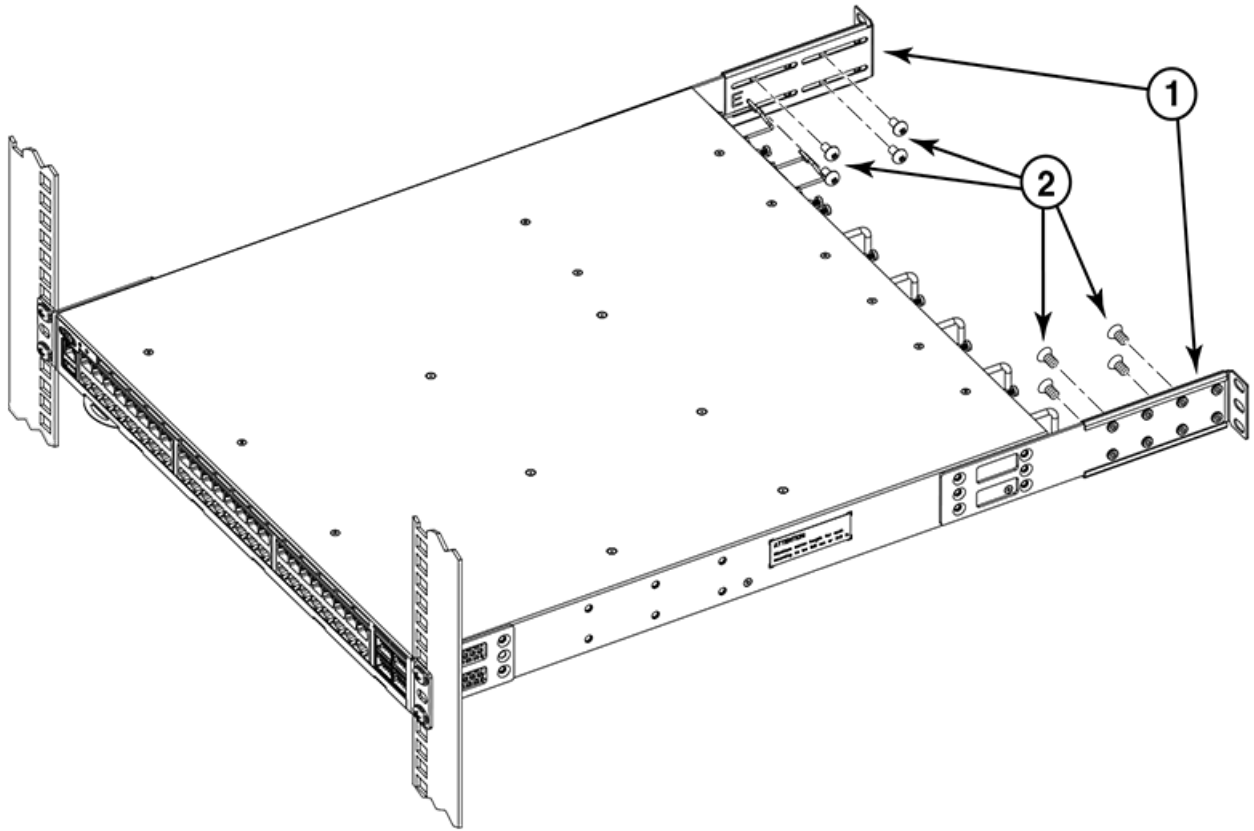

1. Rear brackets

2. Screws, 6-32 x 1/4-in., panhead Phillips

FIGURE 38 Attaching the medium or long rear brackets to the extensions

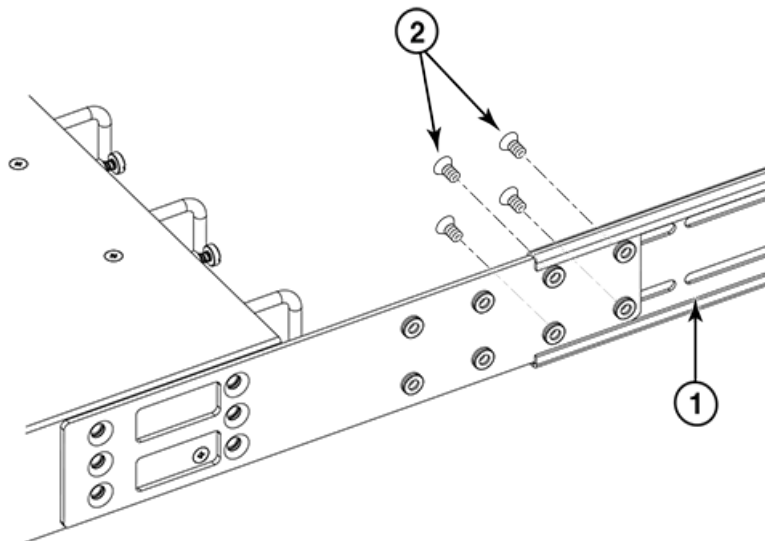

1. Rear bracket, medium or long
2. Screws, 6-32 x 1/4-in., panhead Phillips

Attaching the rear brackets to the rack posts

Complete the following steps to attach the rear brackets to the rack posts.

1. Attach the right rear bracket to the right rear rack post using two 10-32 x 5/8-in. panhead screws and two retainer nuts, as shown in [Figure 39](#). Use the upper and lower holes in the bracket.
2. Attach the left rear bracket to the left rear rack post using two 10-32 x 5/8-in. panhead screws and two retainer nuts. Use the upper and lower holes in the bracket.
3. Tighten all the 10-32 x 5/8-in. screws to a torque of 25 in-lb (29 cm-kg).

FIGURE 39 Attaching the rear brackets to the rack posts

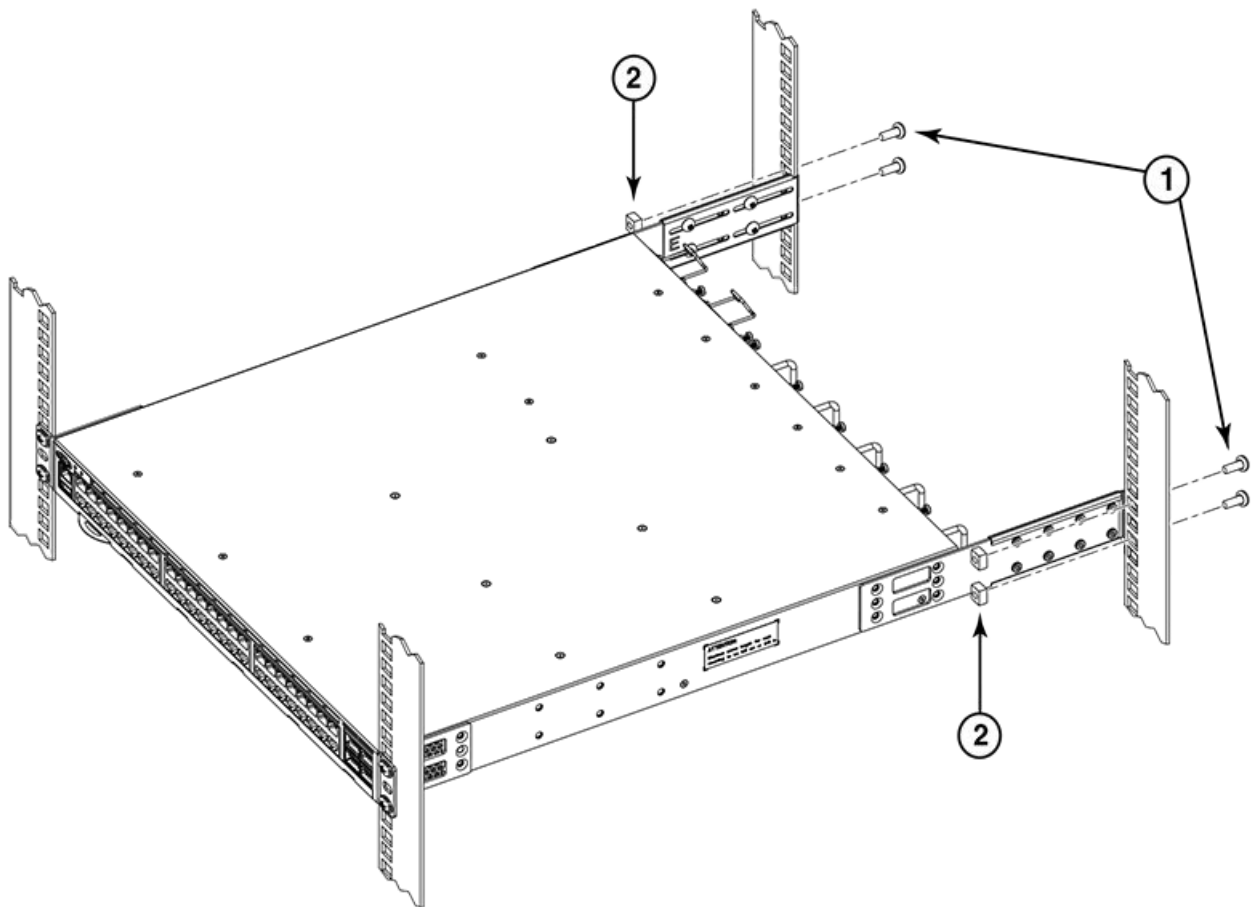

1. Screws, 10-32 x 5/8-in., panhead Phillips

2. Retainer nuts, 10-32

Mounting the Device

Flush-rear (recessed) mounting the device in the rack

Flush-rear (recessed) mounting the device in the rack

The flush-rear (recessed) mounting is similar to the flush-front mounting except that the brackets are reversed on the device.



CAUTION

The device must be turned off and disconnected from the fabric during this procedure.

NOTE

Illustrations used in these rack installation procedures are for reference only and may not show the actual device that you are installing.

Complete the following tasks to install the device in a four-post rack:

1. [Attaching the front brackets to the rear of the device](#) on page 62
2. [Attaching the bracket extensions to the front of the device](#) on page 63
3. [Installing the device in the rack](#) on page 64
4. [Attaching the rear brackets to the bracket extensions at the front of the device](#) on page 65
5. [Attaching the rear brackets to the front rack posts](#) on page 67

Attaching the front brackets to the rear of the device

NOTE

In this installation, the brackets are named as listed in the parts list even though the installation of the brackets is reversed from the flush-front installation.

Complete the following steps to attach the front brackets to the rear of the device.

1. Position the right front bracket with the flat side against the right rear side of the device, as shown in [Figure 40](#).
2. Insert four 8-32 x 5/16-in. flathead screws through the vertically aligned holes in the bracket and then into the holes on the side of the device. Use the upper and lower screw holes, leaving the center holes empty.
3. Repeat [Step 1](#) and [Step 2](#) to attach the left front bracket to the left rear side of the device.

4. Tighten all the 8-32 x 5/16-in. screws to a torque of 15 in-lb (17 cm-kg).

FIGURE 40 Attaching the front brackets to the rear of the device

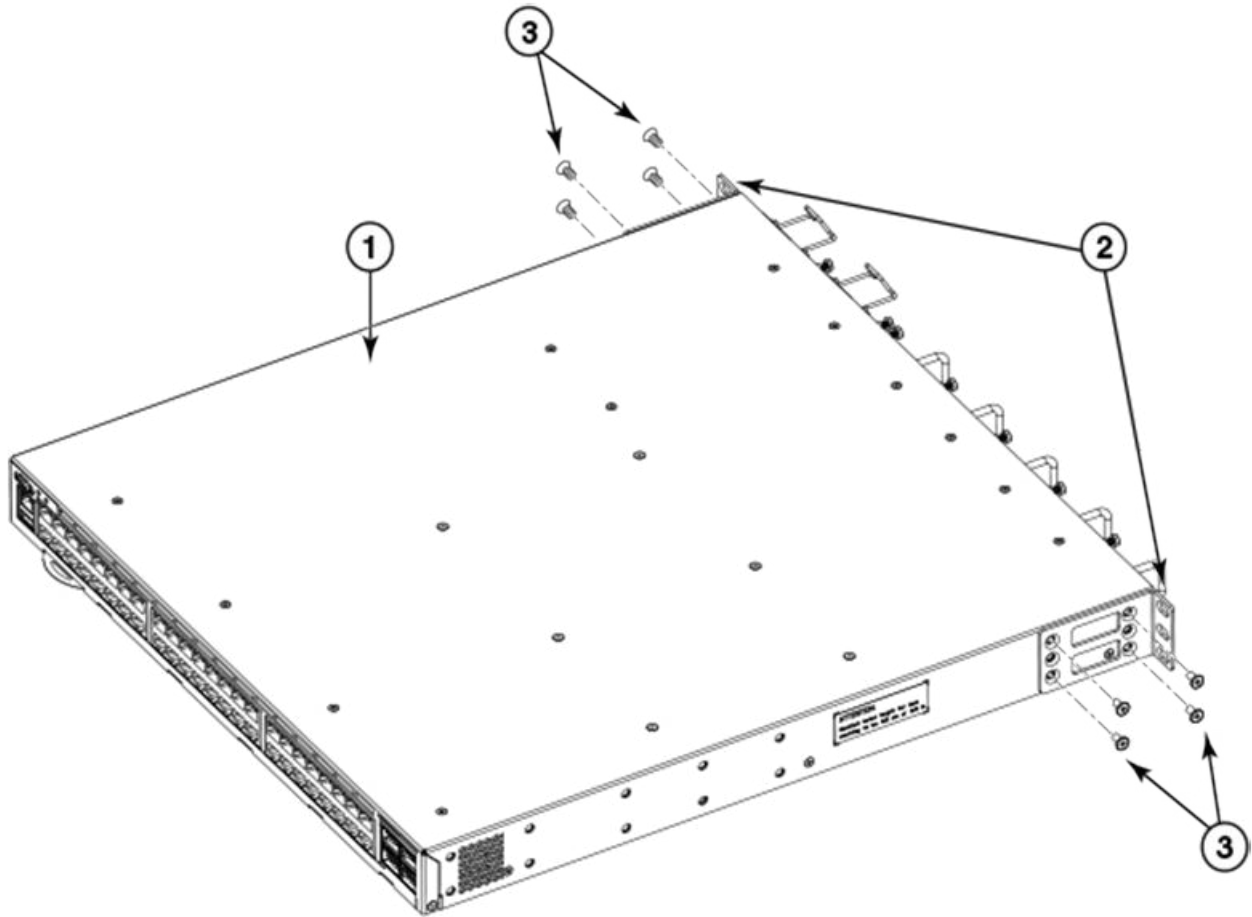

1. Brocade device
2. Front brackets

3. Screws, 8-32 x 5/16-in., flathead Phillips

Attaching the bracket extensions to the front of the device

Complete the following steps to attach the bracket extensions to the front of the device.

1. Position the right bracket extension along the side of the device as shown in [Figure 41](#).
2. Insert four 8-32 x 5/16-in. flathead screws through the vertically aligned holes in the bracket extension and then into the holes on the side of the device. Use the upper and lower screw holes, leaving the center holes empty.
3. Repeat step 1 and step 2 to attach the left front bracket extension to the left side of the device.

Mounting the Device

Flush-rear (recessed) mounting the device in the rack

4. Tighten all the 8-32 x 5/16-in. screws to a torque of 15 in-lb (17 cm-kg).

FIGURE 41 Attaching the bracket extensions to the device

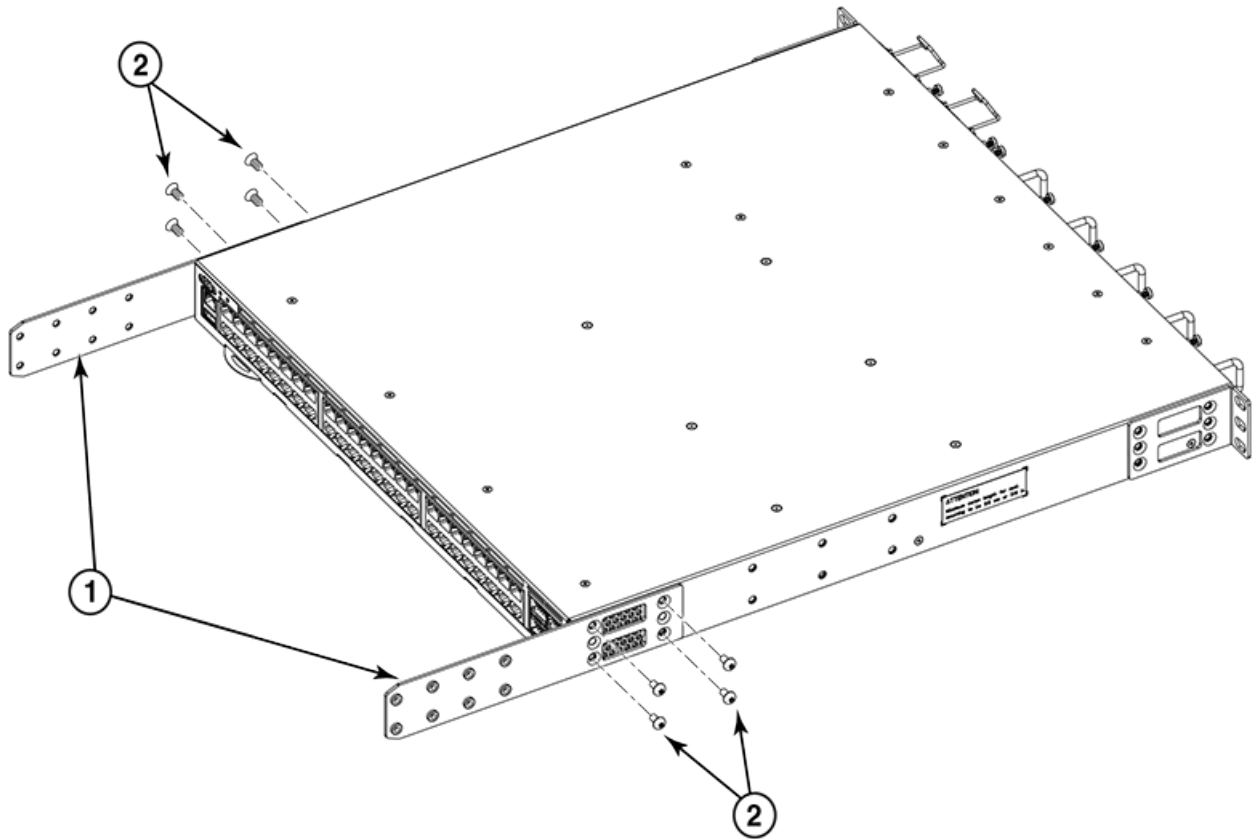

1. Bracket extensions

2. Screws, 8-32 x 5/16-in., flathead Phillips

Installing the device in the rack

Complete the following steps to install the device in the rack.

1. Position the device in the rack, as shown in [Figure 42](#), providing temporary support under the device until the rail kit is secured to the rack.
2. Attach the right front bracket to the right rear rack post using two 10-32 x 5/8-in. panhead screws and two retainer nuts. Use the upper and lower holes in the bracket.
3. Attach the left front bracket to the left rear rack post using two 10-32 x 5/8-in. panhead screws and two retainer nuts. Use the upper and lower holes in the bracket.

4. Tighten all the 10-32 x 5/8-in. screws to a torque of 25 in-lb (29 cm-kg).

FIGURE 42 Positioning the device in the rack

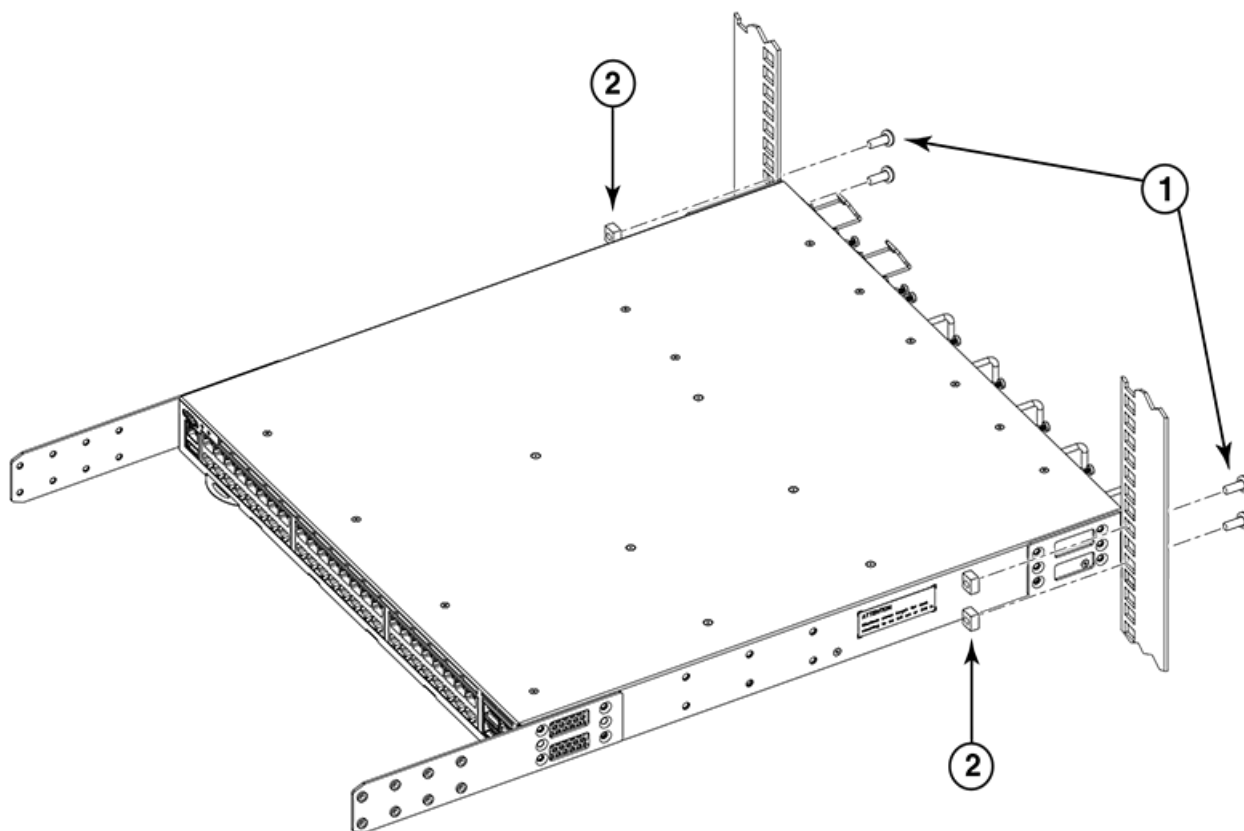

1. Screws, 10-32 x 5/8-in., panhead Phillips

2. Retainer nuts, 10-32

Attaching the rear brackets to the bracket extensions at the front of the device

Complete the following steps to attach the rear brackets to the bracket extensions. There are short, medium, and long front brackets that you can use for this step.

1. Select the proper length rear bracket for your rack depth.
2. Slide the right rear bracket onto the right extension, as shown in [Figure 43](#).

The short rear brackets are shown. Use the first and third vertical pairs of holes for the screws.

Refer to [Figure 44](#) for the positioning of the medium or long brackets and screws.

3. Attach the brackets using four 6-32 x 1/4-in. panhead screws.
4. Repeat [Step 2](#) and [Step 3](#) to attach the left rear bracket to the left extension.

Mounting the Device

Flush-rear (recessed) mounting the device in the rack

- Adjust the brackets to the rack depth and tighten all the 6-32 x 1/4-in. screws to a torque of 9 in-lb (10 cm-kg).

FIGURE 43 Attaching the short rear brackets to the extensions at the front of the device

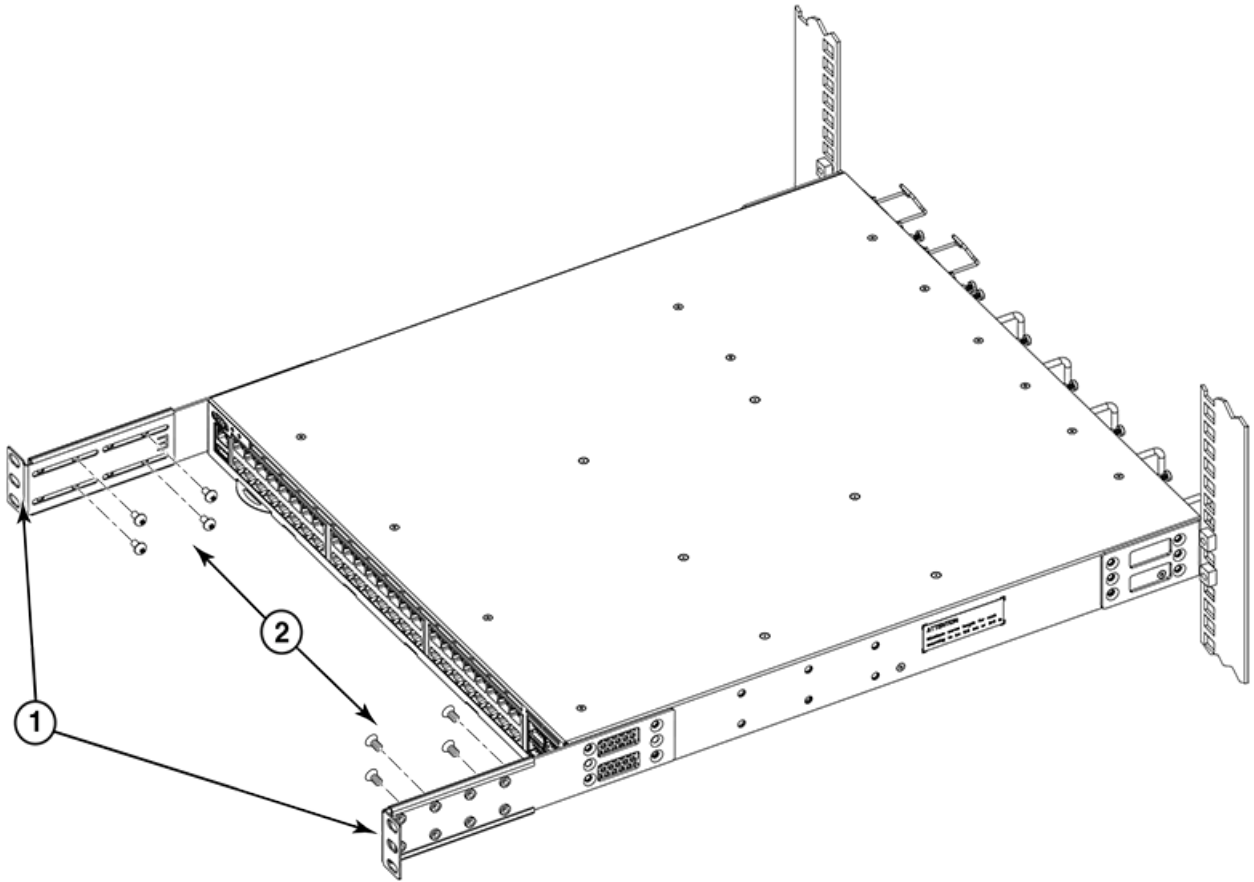

1. Rear brackets, short

2. Screws, 6-32 x 1/4-in., panhead Phillips

FIGURE 44 Attaching the medium or long rear brackets to the extensions

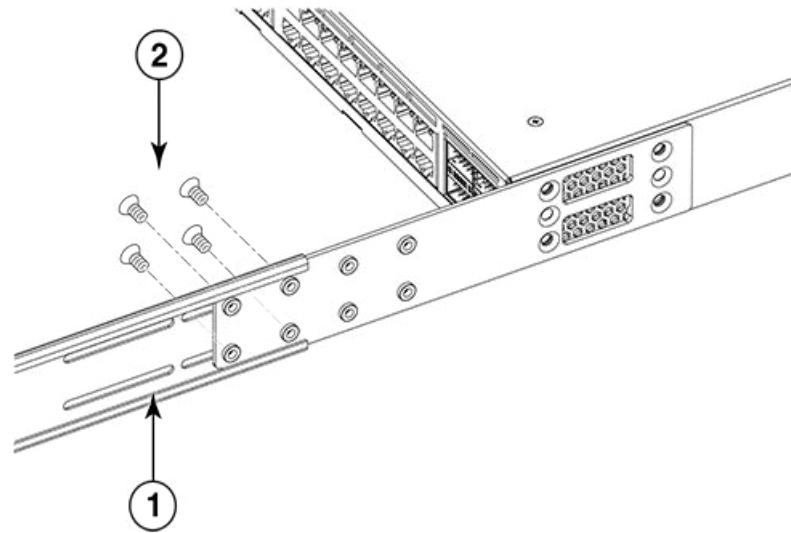

1. Rear bracket, medium or long

2. Screws, 6-32 x 1/4-in., panhead Phillips

Attaching the rear brackets to the front rack posts

Complete the following steps to attach the rear brackets to the front rack posts.

1. Attach the right rear bracket to the right front rack post using two 10-32 x 5/8-in. screws and two retainer nuts, as shown in [Figure 45](#). Use the upper and lower holes in the bracket.
2. Attach the left rear bracket to the left front rack post using two 10-32 x 5/8-in. screws and two retainer nuts. Use the upper and lower holes in the bracket.

Mounting the Device

Flush-rear (recessed) mounting the device in the rack

3. Tighten all the 10-32 x 5/8-in. screws to a torque of 25 in-lb (29 cm-kg).

FIGURE 45 Attaching the rear brackets to the front rack posts

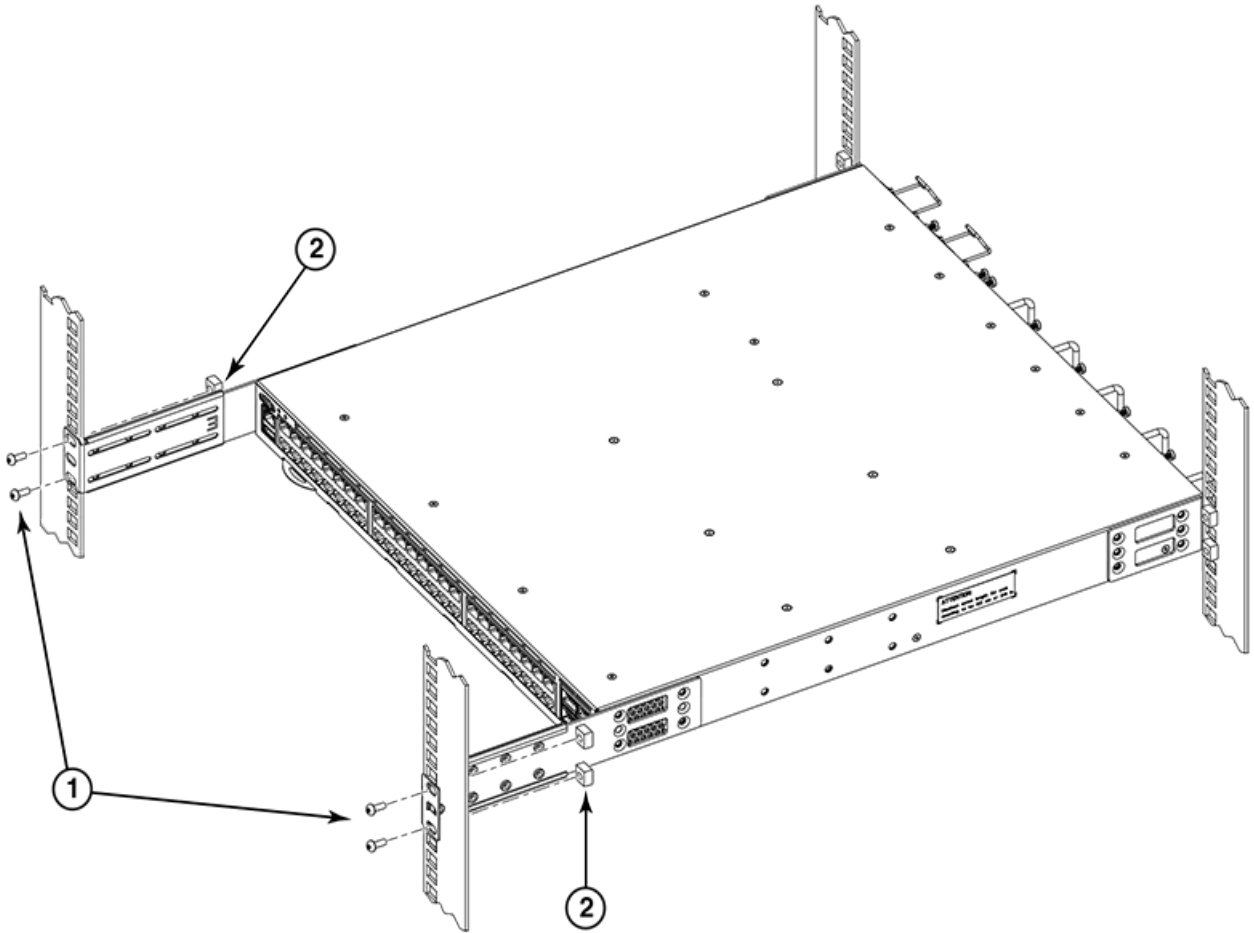

1. Screws, 10-32 x 5/8-in., panhead Phillips

2. Retainer nuts, 10-32

Connecting ICX 7150 Devices in a Stack

- Stacking configuration requirements..... 69
- ICX 7150 stacking ports..... 69
- ICX 7150 stacking topologies..... 71

Stacking configuration requirements

Before configuring a traditional stack using the CLI, physically connect the devices with stacking cables. For more information on configuring a stack, refer to the *FastIron Stacking Configuration Guide*.

ICX 7150 stacking ports

Depending on the model, up to eight SFP+ ports on the front panel of the ICX 7150 device support stacking. The ports can also be used as uplink (data) ports. The following figures show the location and numbering for stacking ports. The numbering for the ports is in three-tuple format ($x/y/z$) and refers to StackID/Slot/Port.

ICX 7150-C12P devices have two stacking ports on the front panel as shown in the following figure.

FIGURE 46 ICX 7150-C12P stacking ports

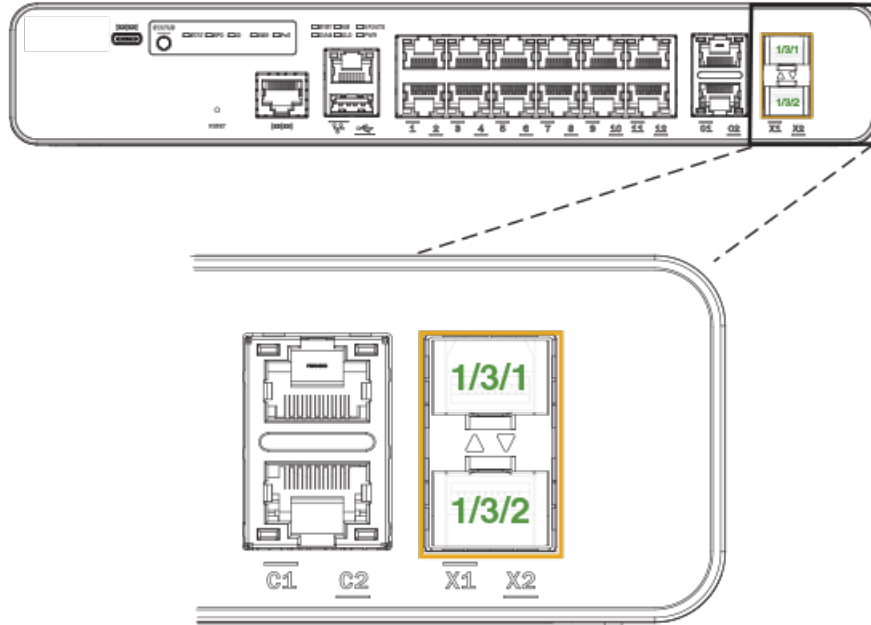

ICX 7150-24 and ICX 7150-24P devices have four stacking ports on the front panel as shown in the following figure.

Connecting ICX 7150 Devices in a Stack
 ICX 7150 stacking ports

FIGURE 47 ICX 7150 stacking port location on 24-port and some 48-port models

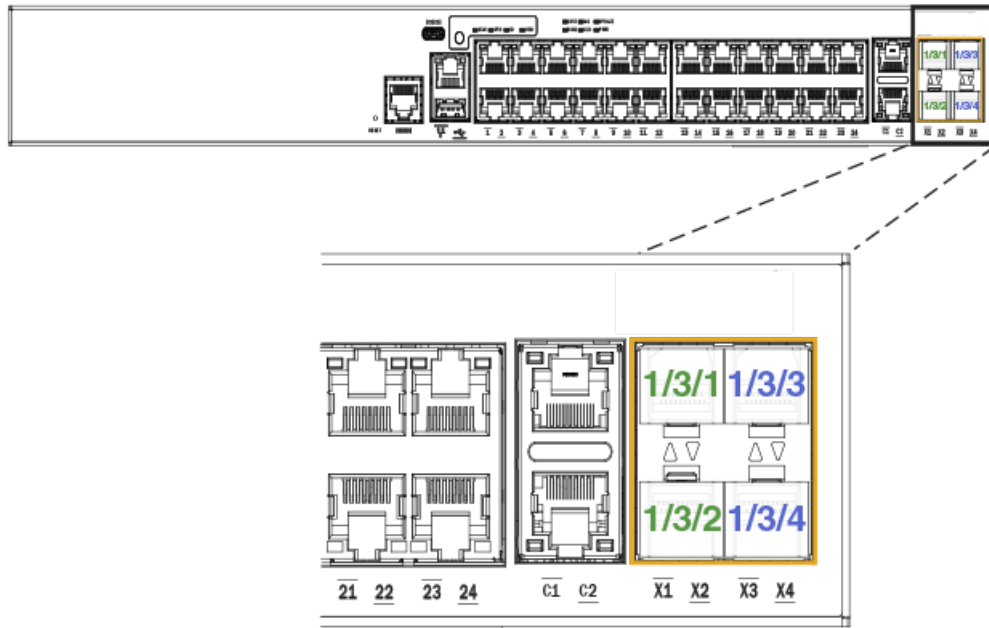

ICX 7150-48, ICX 7150-48P, and ICX 7150-48PF devices have four stacking ports in the same location on the front panel as ICX 7150 24-port models.

The exception among 48-port models is the ICX 7150-48PZ, which has eight SPF+ ports on the front panel as shown in the following figure. Four of these ports, ports 1/2/1 through 1/2/4, can be used as stacking or data uplink ports. The remaining four, 1/2/5 through 1/2/8, can be used only as data uplink ports.

FIGURE 48 ICX 7150-48PZ stacking ports

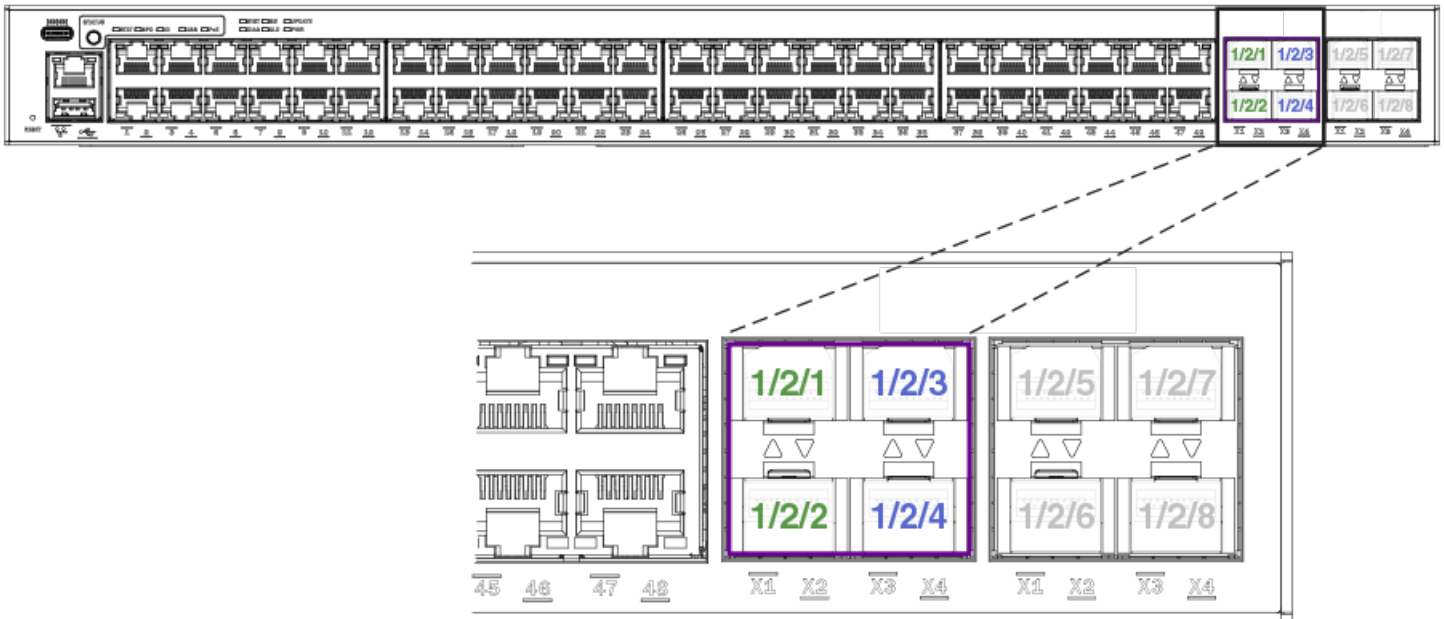

ICX 7150 stacking topologies

Both linear and ring topologies are supported in a traditional stack. In a linear stack topology, a connection between each switch carries two-way communications across the stack. The physical connection between the devices can use one port (stacked-port) or two ports (stacked-trunk) per trunk.

In ring stack topology, an extra connection between the logical first and last devices forms a "ring" or "closed-loop." The closed-loop connection provides a redundant path for the stack link, so if one link fails, stack communications can be maintained. You can connect stacking units using one port per trunk or both ports in a trunk. For maximum bandwidth and link redundancy, use both ports per trunk.

Linear and ring topologies are depicted for different ICX 7150 models in the following figures.

NOTE

Port numbers shown are specific to each physical unit; that is, the unit ID is 1, in the three-tuple StackID/slot/port notation. Assuming the stack in the following figure is numbered from the bottom when it is configured, the connected stacking port for the bottom stack (stack unit 1) would be identified as port 1/3/2, and the connected port in the middle stack unit (stack unit 2) would be identified as 2/3/1. Port 2/3/2 in the middle stack unit would be shown as connecting to port 3/3/1 in the top unit (stack unit 3).

NOTE

The Secure-setup utility used to discover and configure the stack assigns each unit a different stack ID. You can override the automatic selection if you choose. Refer to the *FastIron Stacking Configuration Guide* for more information.

The following figures show examples of supported stacking topologies for the ICX 7150-C12P.

FIGURE 49 ICX 7150-C12P linear stack



Connecting ICX 7150 Devices in a Stack ICX 7150 stacking topologies

FIGURE 50 ICX 7150-C12P ring topology



The following figures show examples of supported topologies for ICX 7150 24-port models.

FIGURE 51 ICX 7150 24-port model, linear stack

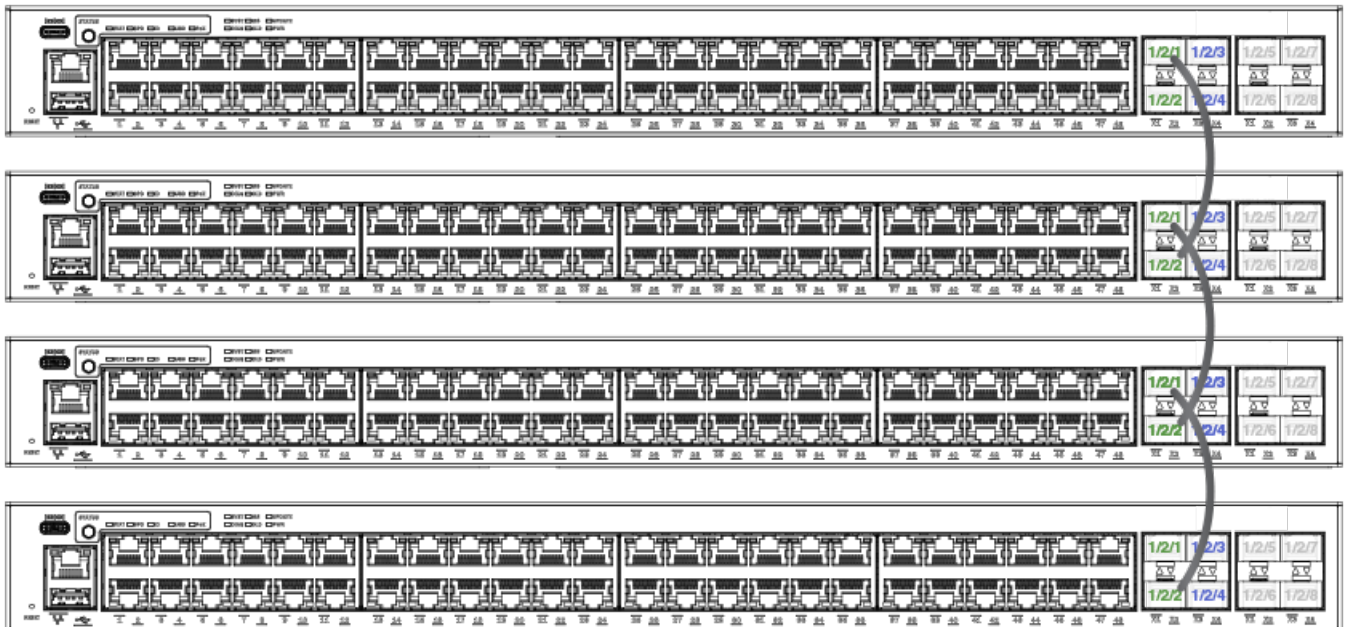

FIGURE 52 ICX 7150 24-port model, ring stack



The following figures show examples of supported topologies for the ICX 7150-48ZP.

FIGURE 53 ICX7150-48ZP linear stack



Connecting ICX 7150 Devices in a Stack
ICX 7150 stacking topologies

FIGURE 54 ICX 7150-48ZP ring stack

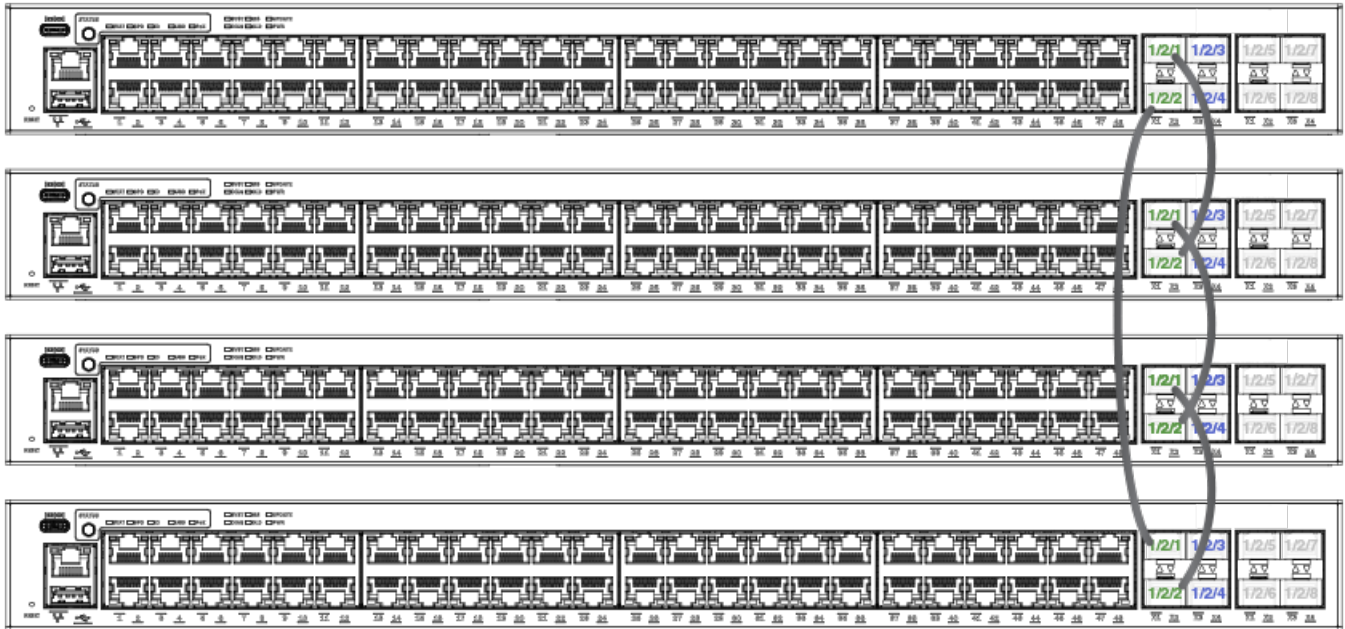

Initial Setup and Verification

• Items required.....	75
• Providing power to the device.....	75
• Establishing a first-time connection to the console port.....	76
• Configuring an IP address for the device.....	79
• Customizing the host name and chassis name	79
• Setting the date and time.....	80
• Establishing a connection to the out-of-band management port.....	80
• Getting in-band access.....	81
• Verifying the correct operation.....	81
• Backing up the running configuration.....	81

Items required

The following items are required for initial setup and verification of the device:

- The device, mounted and installed with the required power supply, fan assemblies, transceivers, and cables
- A workstation computer with a terminal emulator application installed, such as HyperTerminal for Windows
- An unused IP address with corresponding subnet mask and gateway address
- An USB console cable with Type-C connector (Type-C USB cable not included with the device)
- A serial console cable with an RJ-45 connector (RJ-45 console cable not included with the device)
- An Ethernet cable
- Access to a TFTP server or USB removable media for backing up (uploading) or downloading the device configuration (optional)

Providing power to the device

Perform the following steps to provide power to the device.

1. Remove the power cord and the power cord retainer clip from the shipping carton container.
2. Install the power cord retainer clip to the power supply inlet on the device.
3. Connect the power cord to the power supply inlet on the device. Ensure that the power cords have a minimum service loop of 6 inches available and are routed properly to avoid stress.
4. Insert the power cord plug to power sources on separate circuits if there is more than one power cord for a single device in order to protect against power failure.
5. If applicable, power on the power sources by flipping the switches to the on position. The SYST LED displays amber until power-on self-test (POST) is complete and then starts blinking green until the device is completely up. The device usually requires several minutes to boot and complete POST.

NOTE

Power is supplied to the device as soon as the first power supply is connected and turned on. If the power indicator does not turn on when the power cord is plugged in, you may have a problem with the power outlet, power cord, or internal power supply.

Initial Setup and Verification

Establishing a first-time connection to the console port

6. After POST is complete, verify that the switch power and switch status LEDs are green.

NOTE

Power Supply LED should always display solid green to ensure a working power supply. If the LED is amber, it indicates a faulty PSU.

For more information about how to interpret POST, BOOT, and diagnostics tests, refer to [Monitoring the Device](#) on page 91.

Establishing a first-time connection to the console port

You can use either the USB Type-C console port or the RJ-45 serial console port to establish the first time connection to the device. The console port allows you to configure and manage the device using a third-party terminal emulation application from a workstation that is directly connected to the port using a standard USB Type-C cable or RJ-45 serial cable. Perform the following steps to log in to the device for the first time through the console connection.

1. Do one of the following:
 - Connect a standard USB cable to the USB Type-C console connector on the device and to a USB port on the workstation. To connect the USB Type-C console port on the device to a USB port on the workstation, you need a standard USB cable that has a USB Type-C connector on one end and a USB connector on the other end that matches the USB port on your workstation.
 - Connect a standard RJ-45 cable to the RJ-45 serial console connector on the device and to a USB port on the workstation. To connect the RJ-45 serial console port on the device to a USB port on the workstation, you need a standard RJ-45 cable that has a RJ-45 connector on one end and a USB connector on the other end that matches the USB port on your workstation.
2. Allow the workstation to automatically discover and configure the newly found USB device.

NOTE

If the workstation is unable to automatically discover and configure the newly found USB device, you can manually download the necessary device drivers for Windows, MacOS, and Linux from the following website: <http://my.brocade.com>

3. Open a terminal emulator application such as HyperTerminal on a Windows PC, or TERM, TIP, or Kermit in a UNIX environment, and configure the sessions parameters as follows:

- In a Windows environment, use the following values:

Parameter	Value
Baud: Bits per second	9600
Data bits	8
Parity	None
Stop bits	1
Flow control	None

NOTE

Flow control is not supported on the console connection when attached to a remote terminal and must be disabled on the customer-side remote terminal server in addition to the host-side clients.

- In a UNIX environment using TIP, enter the following string at the prompt:

```
tip /dev/ttyb -9600.
```

If ttyb is already in use, use ttya instead and enter the following string at the prompt:

```
tip /dev/ttya -9600
```

4. When the terminal emulator application stops reporting information, press **Enter** to display the device prompt.

Depending on the device you purchased, and the code (Layer 2 or Layer 3) loaded on your system, the device prompt is displayed accordingly.

```
device>
```

When the device prompt is displayed, you are connected to the device. You can customize the prompt by changing the device name. If you do not see this prompt, make sure the cable is securely connected to your workstation and to the device and check the settings in your terminal emulation program. In addition to the previously configured session settings, make sure the terminal emulation session is running on the same serial port you attached to the device.

The device CLI prompt has the following access levels:

- User EXEC: This is the level you enter when you first start a CLI session. At this level, you can view some system information but you cannot configure system or port parameters.
- Privileged EXEC: This level is also called the Enable level and can be secured by a password. You can perform tasks such as managing files on the flash module, saving the system configuration to flash, and clearing caches at this level.
- CONFIG: The configuration level. This level allows you to configure the system IP address and configure switching and routing features. To access the CONFIG mode, you must already be logged in to the privileged EXEC level.

Initial Setup and Verification

Establishing a first-time connection to the console port

- At the opening CLI prompt, enter the following command to change to the Privileged EXEC mode:

```
device> enable
device#
```

By default, the CLI is not protected by passwords. To secure CLI access, Brocade strongly recommends assigning passwords.

You can set the following levels of passwords:

- Super User: Allows complete read-and-write access to the system. This is generally for system administrators and is the only password level that allows you to configure other passwords.

NOTE

You must set a Super User password before you can set other types of passwords. You can also assign other passwords using Brocade Network Advisor after an enable password has been configured for a Super User on the device using the CLI.

- Port Configuration: Allows read-and-write access to specific ports but not for global (system-wide) parameters.
- Read-Only: Allows access to the privileged EXEC mode and CONFIG mode but only with read access.

NOTE

Passwords can be up to 32 characters long. They must begin with an alphabetic character. They can include numeric characters, the period (.), and the underscore (_) only. Passwords are case-sensitive, and they are not displayed when you enter them on the command line.

- Access the configuration mode of the CLI by entering the following command:

```
device# configure terminal
device(config)#
```

- Enter the following command to set the Super User password:

```
device(config)# enable super-user-password joe
```

NOTE

Make sure to write down the new passwords and keep the information in a secure location.

- Enter the following commands to set the port configuration and read-only passwords.

```
device(config)# enable port-config-password john
device(config)# enable read-only-password sam
```

Recovering from a lost password

If a password has been configured for the device but the password has been lost, you can regain Super User access to the device using the following procedure.

Recovery from a lost password requires direct access to the serial port and a system reset.

- Start a CLI session over the serial interface to the Brocade device.
- Reboot the device.
- While the system is booting, before the initial system prompt appears, enter **b** to enter the boot monitor mode.
- Enter **no password**. (You cannot abbreviate this command.)
- Enter **boot**. This command causes the device to bypass the system password check.
- After the console prompt reappears, assign a new password.

Configuring an IP address for the device

You must configure at least one IP address using the serial connection to the CLI before you can manage the device using the other management interfaces. You can use the classical IP network masks (Class A, B, and C subnet masks, and so on) or Classless Interdomain Routing (CIDR) network prefix masks.

- To enter a classical IP network mask, enter the mask in IP address format. For example, enter "10.157.22.99 255.255.255.0" for an IP address with a Class C subnet mask.
 - To enter a prefix number for a network mask, enter a forward slash (/) and the number of bits in the mask immediately after the IP address. For example, enter "10.157.22.99/24" for an IP address that has a network mask with 24 significant ("mask") bits.
1. At the opening CLI prompt, enter the following commands.

```
device> enable
device# erase startup-config
device# configure terminal
```

NOTE

Use the **erase startup-config** command only for new systems. If you enter this command on a system you have already configured, the command erases the configuration. If you accidentally erase the configuration on a configured system, enter the **write memory** command to save the running configuration to the startup-config file.

2. Enter the following commands to assign an IP address for a device running Layer 2 software.

```
device(config)# ip address 10.22.3.44 255.255.255.0
device(config)# ip default-gateway 10.22.3.1
device(config)# write memory
```

NOTE

You do not need to assign a default gateway address for single subnet networks.

Enter the following commands to add an IP address and mask to a router port on a device running Layer 3 software.

```
device(config)# interface ethernet 1
device(config)# ip address 10.22.3.44 255.255.255.0
device(config)# write memory
```

NOTE

Before attaching any equipment to a device running Layer 3 software, you must assign an interface IP address to the subnet on which the device will be located. You must use the serial connection to assign the first IP address. For subsequent addresses, you can use the CLI through Telnet.

3. Assign an interface IP address to the out-of-band management Ethernet port.

```
device(config)# interface management 1
device(config)# ip address 10.22.3.45 255.255.255.0
device(config)# write memory
```

The management port number is always 1.

Customizing the host name and chassis name

Changing the host name, contact, and location is important for distinguishing and identifying the device uniquely and for accurate tracking of logs and errors. The messages that appear in the log are labeled with the chassis name, which makes tracking the errors much easier. Specify an easily understandable and meaningful host name and chassis name.

Initial Setup and Verification

Setting the date and time

Perform the following steps to change the host name and then the chassis name.

1. Customize the host name, contact, and location using the following commands. When you configure a host name, the name replaces the default system name in the device CLI prompt.

```
device(config)# hostname sj_device1
sj_device1(config)# snmp-server contact Support Services
sj_device1(config)# snmp-server location San Jose
sj_device1(config)# end
sj_device1# write memory
```

The name, contact, and location each can be up to 255 alphanumeric characters. The text strings can contain blanks. The SNMP text strings do not require quotation marks when they contain blanks but the host name does.

2. Change the chassis name by using the **chassis name** command.

```
device(config)# chassis name SJ001
sj_device1(config)# end
sj_device1# write memory
```

The **chassis name** command does not change the device CLI prompt. Instead, the command assigns an administrative ID to the device.

Setting the date and time

Use the following command to set the current date and time for the device.

```
device# clock set
hh:mm:ss Current Time
device# clock set 10:05:45
mm-dd-yy/yyyy Current Date
device# clock set 10:05:45 12-01-16
```

Establishing a connection to the out-of-band management port

The out-of-band management interface is an RJ-45 Ethernet port that allows you to access, configure, and manage the device from the network. Perform the following steps to establish a connection to the device using the out-of-band Ethernet management port.

1. Remove the plug from the RJ-45 management port.
2. Connect an Ethernet cable to the device RJ-45 management port and to the workstation or to an Ethernet network containing the workstation.

NOTE

At this point, the device can be accessed remotely using the CLI or Brocade Network Advisor. Ensure that the device is not being modified from any other connections. The Ethernet management port also supports auto-MDI and auto-MDIX.

Getting in-band access

You can access the management agent in the device from anywhere within the attached network using Telnet or other network management software. However, you must first configure the device with a valid IP address, subnet mask, and default gateway. If you have trouble establishing a link to the management agent, check to see if you have a valid network connection. Then verify that you entered the correct IP address. Also, be sure the port through which you are connecting to the device has not been disabled. If it has not been disabled, then check the network cabling that runs between your remote location and the device.

Verifying the correct operation

Check the LEDs to verify operation of functional parts. The following commands can be useful to establish an operational baseline for the device. Refer to the *Ruckus FastIron Command Reference* for more information on these commands.

- `show chassis`
- `show version`
- `show cpu`
- `show flash`
- `show files`
- `show run`
- `show boot-preference`
- `show configuration`
- `show running-config`
- `show logging`

Backing up the running configuration

Use the `write memory` command to replace the startup configuration with the running configuration every time you make changes to the device configuration. To back up the device configuration to an external TFTP server, use the `copy running-config tftp` command.

```
device# copy running-config tftp 2001:DB8:e0ff:7837::3 newrun.cfg
```

This command example copies the running configuration to a TFTP server with the IPv6 address of 2001:DB8:e0ff:7837::3 and names the file on the TFTP server newrun.cfg.

Installing Transceivers and Cables

- Time and items required..... 83
- Precautions specific to transceivers and cables..... 83
- Managing cables..... 84
- Installing the Ethernet RJ-45 cables..... 84
- Cleaning the fiber-optic connectors..... 86
- Installing a new fiber-optic transceiver..... 86
- Cabling a fiber-optic transceiver..... 87
- Replacing a fiber-optic transceiver..... 88

Time and items required

The installation or replacement procedure for one transceiver takes less than five minutes. Ensure that the following items are available:

- Required number of compatible power cables
- Required number of supported Ruckus-branded transceivers
- Refer to the Brocade optics family datasheet for the list of supported transceivers and cables.
- Required number of compatible Ethernet (RJ-45) and fiber-optic cables
- Optical transceiver extraction tool (for 10-Gbps transceiver only)

NOTE

Most Ruckus switches come with a transceiver extraction tool and holster. The extraction tool is designed to remove transceivers from modules where the space is limited.

FIGURE 55 Optical transceiver extraction tool



Precautions specific to transceivers and cables



DANGER

The procedures in this manual are for qualified service personnel.



DANGER

For safety reasons, the ESD wrist strap should contain a series 1 megaohm resistor.



DANGER

All fiber-optic interfaces use Class 1 lasers.



DANGER

Use only optical transceivers that are qualified by Brocade Communications Systems, Inc. and comply with the FDA Class 1 radiation performance requirements defined in 21 CFR Subchapter I, and with IEC 60825 and EN60825. Optical products that do not comply with these standards might emit light that is hazardous to the eyes.



CAUTION

Before plugging a cable into any port, be sure to discharge the voltage stored on the cable by touching the electrical contacts to ground surface.

Managing cables

Cables can be organized and managed in a variety of ways, for example, using cable channels on the sides of the rack or patch panels to minimize cable management. Follow these recommendations:

NOTE

You should not use tie wraps with optical cables because they are easily overtightened and can damage the optic fibers.



CAUTION

Before plugging a cable into any port, be sure to discharge the voltage stored on the cable by touching the electrical contacts to ground surface.

- The minimum bend radius for a 50 micron cable is 2 inches under full tensile load and 1.2 inches with no tensile load.
- Plan for rack space required for cable management before installing the switch.
- Leave at least 1 m (3.28 ft) of slack for each port cable. This provides room to remove and replace the switch, allows for inadvertent movement of the rack, and helps prevent the cables from being bent to less than the minimum bend radius.
- If you are using Brocade ISL Trunking, consider grouping cables by trunking groups. The cables used in trunking groups must meet specific requirements, as described in the Brocade optics family datasheet.
- For easier maintenance, label the fiber-optic cables and record the devices to which they are connected.
- Keep LEDs visible by routing port cables and other cables away from the LEDs.
- Use hook and loop style straps to secure and organize fiber-optic cables.

Installing the Ethernet RJ-45 cables

The device supports connection to other vendors' routers, switches, hubs, as well as other Ruckus devices through the appropriate ports, transceivers, and cables.

- For copper connections to Ethernet hubs, a 10/100Base-TX or 1000Base-T switch, or another Brocade device, a crossover cable is required as shown in the following figure. If the hub is equipped with an uplink port, it requires a straight-through cable instead of a crossover cable. The 802.3ab standard (automatic MDI or MDIX detection) calls for automatic negotiation of the connection between two 1000Base-T ports. In this case, a straight-through cable may work just as well as a crossover cable.

FIGURE 56 UTP crossover cable

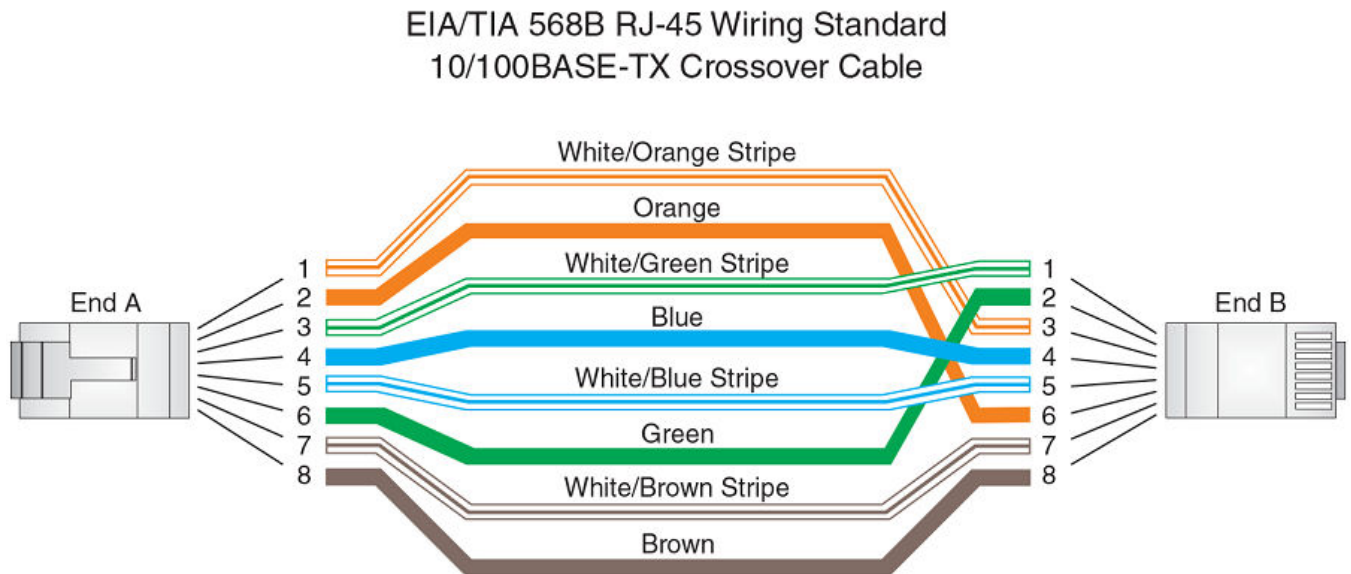

- Straight-through UTP cabling is required for direct UTP attachment to workstations, servers, or routers using network interface cards (NICs). Fiber-optic cabling is required for direct attachment to Gigabit NICs or switches and routers through fiber ports.

FIGURE 57 Straight-through cable



- All 10/100 and 1000 Mbps Ethernet copper ports on the devices support automatic Media Dependent Interface (auto-MDI) or automatic Media Dependent Interface Crossover (auto-MDIX) detection. Auto-MDI or auto-MDIX is enabled on all 10/100 and 1000 Mbps copper ports by default. For each port, you can disable auto-MDI or auto-MDIX, designate the port as an MDI port, or designate the port as an MDIX port.

Cleaning the fiber-optic connectors

To avoid problems with the connection between the fiber-optic transceiver (SFP+ or QSFP) and the fiber cable connectors, Brocade strongly recommends cleaning both connectors each time you disconnect and reconnect them. Dust can accumulate on the connectors and cause problems such as reducing the optic launch power.

To clean the fiber cable connectors, Brocade recommends using a fiber-optic reel-type cleaner. When not using an SFP+, or QSFP connector, make sure to keep the protective covering in place.

Installing a new fiber-optic transceiver

For direct attachment from the device to a Gigabit NIC, switch, or router, using a fiber-optic transceiver, you need fiber cabling with an LC connector. You can install a new fiber-optic transceiver in an SFP or SFP+ slot while the device is powered on and running. While installing a transceiver, wear an ESD wrist strap with a plug that can be inserted in the ESD connector on the device.



DANGER

For safety reasons, the ESD wrist strap should contain a series 1 megaohm resistor.



DANGER

All fiber-optic interfaces use Class 1 lasers.

Perform the following steps to install a fiber-optic transceiver.

1. Put on the ESD wrist strap and ground yourself by attaching the clip end to a metal surface (such as an equipment rack) to act as ground.
2. Remove the new transceiver from the protective packaging.

3. Gently insert the transceiver into the slot until it clicks into place. Transceivers are keyed to prevent incorrect insertion.

NOTE

The location of the fiber-optic interface shown is for illustration purposes only. They may be in a slightly different location on the device you are using.

FIGURE 58 Installing a transceiver

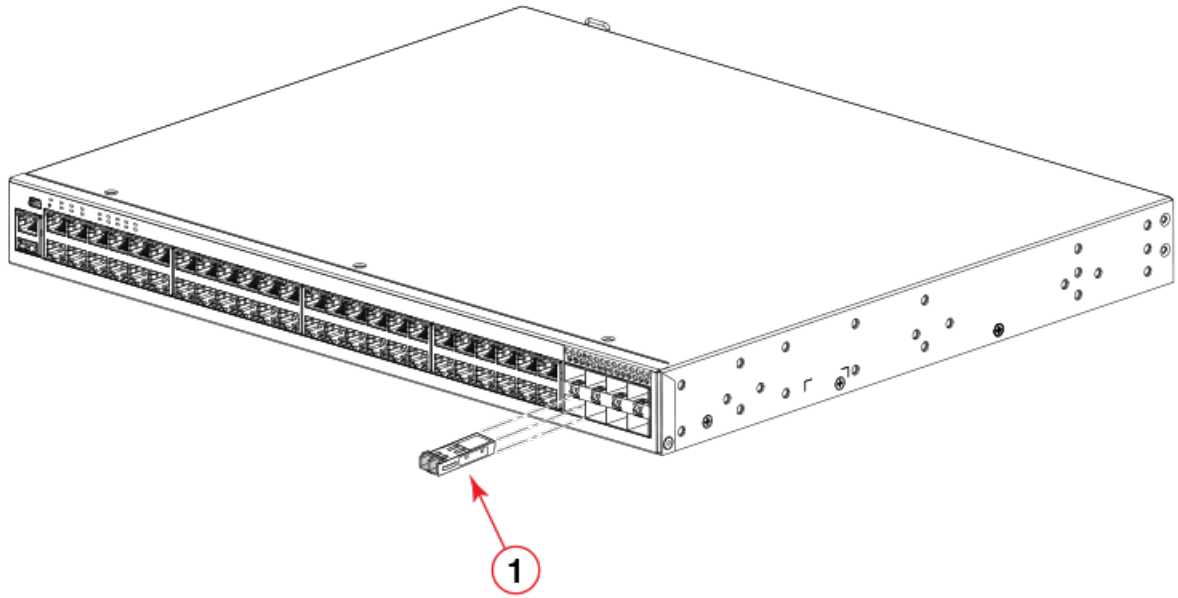

1. Transceiver

NOTE

If a 1-Gbps optic transceiver is inserted, you must configure the port using the **speed-duplex 1000-full-master** command at the interface level.

Cabling a fiber-optic transceiver

Perform the following steps to cable a fiber-optic transceiver.

1. Remove the protective covering from the fiber-optic port connectors and store the covering for future use.

NOTE

Before cabling a fiber-optic transceiver, Ruckus strongly recommends cleaning the cable connectors and the port connectors.

2. Gently insert the cable connector (a tab on each connector should face upward) into the transceiver connector until the tabs lock into place.
3. Observe the link and active LEDs to determine if the network connections are functioning properly.

Replacing a fiber-optic transceiver

You can replace a fiber-optic SFP+ transceiver while the device is powered on and running.

While replacing a fiber-optic module, be sure to wear an ESD wrist strap with a plug that can be inserted in the ESD connector on the device.



DANGER

For safety reasons, the ESD wrist strap should contain a series 1 megaohm resistor.

To replace a transceiver from an SFP+ slot, complete the following steps.

1. Put on the ESD wrist strap and ground yourself by attaching the clip end to a metal surface (such as an equipment rack).
2. Disconnect the cable connector from the port connector.
3. Unlock the transceiver by pulling the bail latch forward, away from the front panel of the module. This unlocks the module from the front panel.

NOTE

On 1000Base-SX ports, the bail latch is enclosed in a black sleeve, and on 1000Base-LX ports, the bail latch is enclosed in a blue sleeve.

FIGURE 59 Unlocking the bail latch



1. Bail latch

NOTE

The bail latch may be attached to either the top or the bottom of the SFP transceiver.

4. Grasp the bail latch and pull the transceiver out of the port.

FIGURE 60 Removing the fiber-optic module

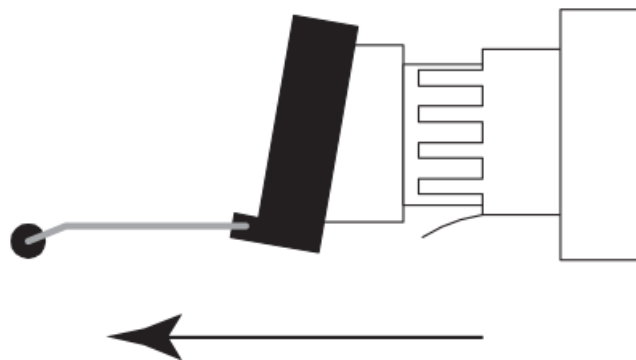

5. Store the transceiver in a safe, static-free place or in an anti-static bag.
6. If you are installing a new module or replacing a module, install the new module in the port.

Monitoring the Device

- Interpreting port-side LEDs.....91
- Interpreting nonport-side LEDs.....98
- Pinging an IP address.....98
- Tracing a route.....98
- Digital optical monitoring.....99
- Monitoring power and cooling.....99

Interpreting port-side LEDs

After you install the network cables, you can observe certain LEDs to determine if the network connections are functioning properly. The tables in this section outline the state of each LED, the status of the hardware, and any recommended action.

FIGURE 61 Port-side LEDs of ICX 7150-C12P

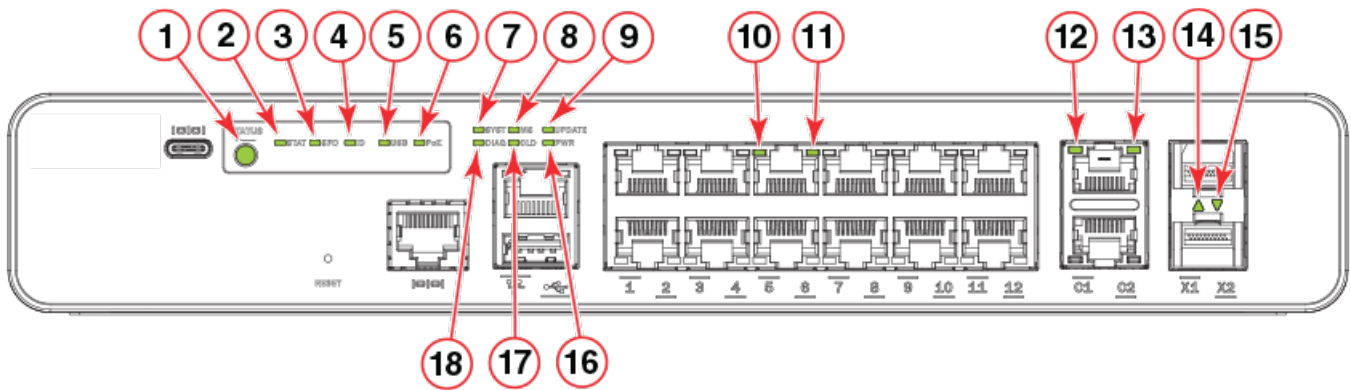

- | | |
|------------------------------------------------------------------------------------------------------------------------------------------------------------------------------------------------------------------------------------------------------------------------------------------------------------------------------------------------------------------------------------|--------------------------------------------------------------------------------------------------------------------------------------------------------------------------------------------------------------------------------------------------------------------------------------------------------------------------------------------------------------------------------------------------------------------------------------------------------------------------------------------------------------------------------------------------------------|
| <ol style="list-style-type: none"> 1. Port status mode selection button 2. Port link status mode LED 3. Port speed status mode LED 4. Member ID status mode LED 5. USB status mode LED 6. PoE status mode LED 7. System Status LED 8. Master/Slave status LED 9. Software update status LED | <ol style="list-style-type: none"> 10. RJ-45 port 5 RX/TX activity LED (if blinking indicates RX/TX activity) 11. PoE LED 12. RJ-45 uplink port C1 status LED 13. RJ-45 uplink port C1 RX/TX activity LED 14. SFP+ uplink port X1 status LED (if blinking indicates RX/TX activity) 15. SFP+ uplink port X2 status LED (if blinking indicates RX/TX activity) 16. Power status LED 17. Cloud management status LED (not currently enabled) 18. Diagnostics status LED |
|------------------------------------------------------------------------------------------------------------------------------------------------------------------------------------------------------------------------------------------------------------------------------------------------------------------------------------------------------------------------------------|--------------------------------------------------------------------------------------------------------------------------------------------------------------------------------------------------------------------------------------------------------------------------------------------------------------------------------------------------------------------------------------------------------------------------------------------------------------------------------------------------------------------------------------------------------------|

Monitoring the Device
Interpreting port-side LEDs

FIGURE 62 Port-side LEDs of ICX 7150-24 and ICX 7150-24P

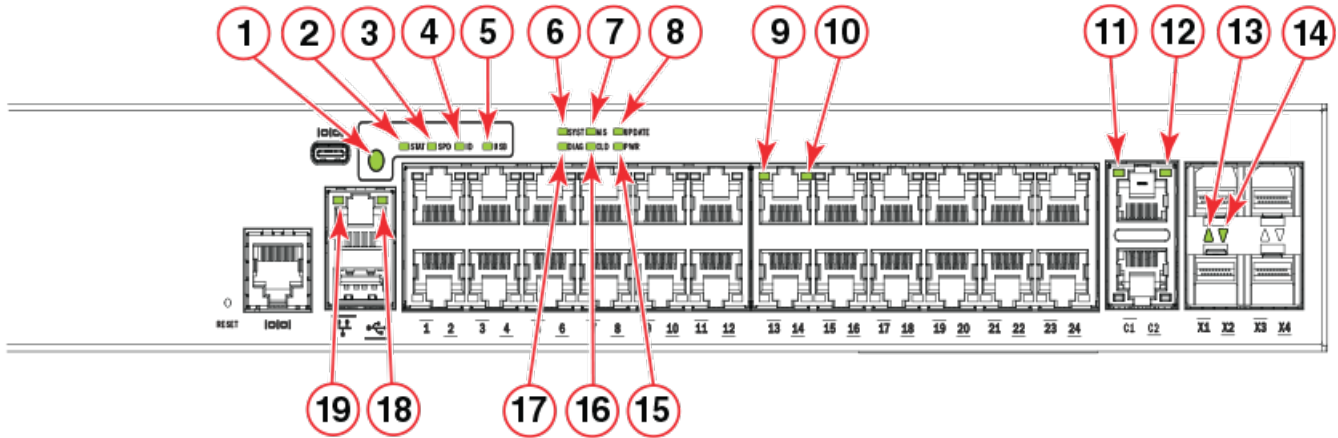

- | | |
|-------------------------------------------------------------------------------------------------------------------------------------------------------------------------------------------------------------------------------------------------------------------------------------------------------------------------------------------------------------------------------------------------------------------------------------------------------------|---------------------------------------------------------------------------------------------------------------------------------------------------------------------------------------------------------------------------------------------------------------------------------------------------------------------------------------------------------------------------------------------------------------------------------------------------------------------------------------------------------------------------------------|
| <ol style="list-style-type: none"> 1. Port status mode selection button 2. Port link status mode LED 3. Port speed status mode LED 4. Member ID status mode LED 5. USB status mode LED 6. System status LED 7. Master/Slave status LED 8. Software update status LED 9. RJ-45 port 13 RX/TX activity LED (if blinking indicates RX/TX activity) 10. PoE LED | <ol style="list-style-type: none"> 11. RJ-45 uplink port C1 status LED 12. RJ-45 uplink port C1 RX/TX activity LED 13. SFP+ uplink port X1 status LED (if blinking indicates RX/TX activity) 14. SFP+ uplink port X2 status LED (if blinking indicates RX/TX activity) 15. Power status LED 16. Cloud management status LED (not enabled currently) 17. Diagnostics status LED 18. OOB Link status LED (left) 19. OOB Speed status LED (right) |
|-------------------------------------------------------------------------------------------------------------------------------------------------------------------------------------------------------------------------------------------------------------------------------------------------------------------------------------------------------------------------------------------------------------------------------------------------------------|---------------------------------------------------------------------------------------------------------------------------------------------------------------------------------------------------------------------------------------------------------------------------------------------------------------------------------------------------------------------------------------------------------------------------------------------------------------------------------------------------------------------------------------|

NOTE

ICX 7150-24P has an additional PoE status mode LED (however not enabled currently) .

FIGURE 63 Port-side LEDs of ICX 7150-48, ICX 7150-48P, and ICX 7150-48PF

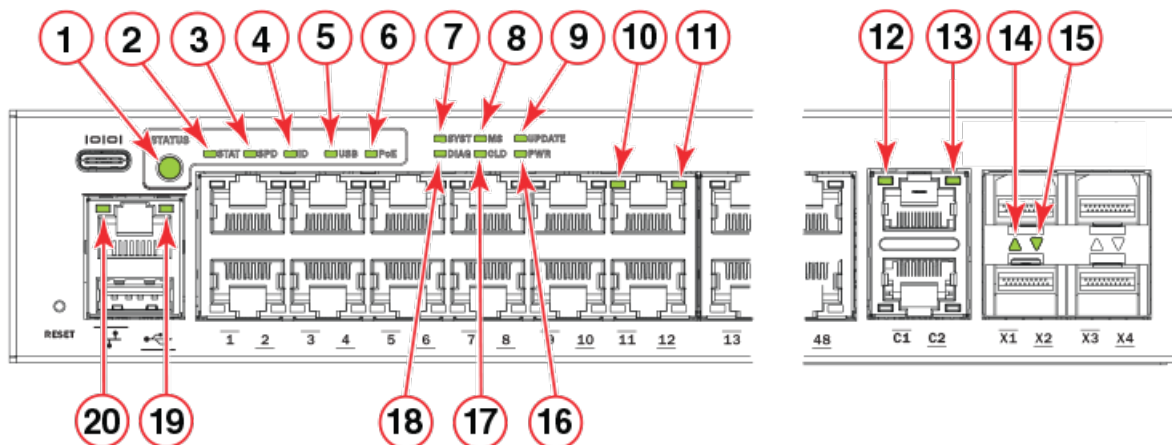

- | | |
|-------------------------------------------------------------------------------------------------------------------------------------------------------------------------------------------------------------------------------------------------------------------------------------------------------------------------------------------------------------------------------------------------------------------------------------------------------------------------|-----------------------------------------------------------------------------------------------------------------------------------------------------------------------------------------------------------------------------------------------------------------------------------------------------------------------------------------------------------------------------------------------------------------------------------------------------------------------------------------------------------------------------------------------------------|
| <ol style="list-style-type: none"> 1. Port status mode selection button 2. Port link status mode LED 3. Port speed status mode LED 4. Member ID status mode LED 5. USB status mode LED 6. PoE status mode LED 7. System status LED 8. Master/Slave status LED 9. Software update status LED 10. RJ-45 port 11 RX/TX activity LED (if blinking indicates RX/TX activity) | <ol style="list-style-type: none"> 11. PoE LED 12. RJ-45 uplink port C1 status LED 13. RJ-45 uplink port C1 RX/TX activity LED 14. SFP+ uplink port X1 status LED (if blinking indicates RX/TX activity) 15. SFP+ uplink port X2 status LED (if blinking indicates RX/TX activity) 16. Power status LED 17. Cloud management status LED (not enabled currently) 18. Diagnostics status LED 19. OOB Link status LED (left) 20. OOB Link status LED (right) |
|-------------------------------------------------------------------------------------------------------------------------------------------------------------------------------------------------------------------------------------------------------------------------------------------------------------------------------------------------------------------------------------------------------------------------------------------------------------------------|-----------------------------------------------------------------------------------------------------------------------------------------------------------------------------------------------------------------------------------------------------------------------------------------------------------------------------------------------------------------------------------------------------------------------------------------------------------------------------------------------------------------------------------------------------------|

NOTE

The ICX 7150-48 does not have the PoE status mode LED.

System LEDs

This section describes the system LEDs.

System status LED

Refer to the following table to interpret the system status LED.

TABLE 12 System status LED during normal operation

LED color	Status of hardware	Recommended action
Off	The device is not powered on.	None
Flashing green	The device is initializing and running initial bootup tests.	None.
Steady green	The device is operating normally.	None.
Steady amber	The device is booting up or has stopped at the booting stage.	None.
Flashing amber	The device is the crash state or the watchdog timeout state.	None.

Monitoring the Device

Interpreting port-side LEDs

Status mode LEDs

You must press the status mode selection button to select the status mode to display the corresponding status on the individual port status LED. Pressing the button once shifts to the next mode in the following sequence:

1. Port link status mode (STAT) (default mode)
2. Port speed status mode (SPD)
3. Member ID status mode (ID)
4. USB status mode (USB)
5. PoE status mode

NOTE

When in USB mode, pressing the status mode selection button for more than 5 seconds initiates the copy files such as the image/manifest file, configuration file, and Show Tech (supportsave) from the device to the USB.

Port status mode (STAT) LED

The port status mode (STAT) LED displays the link status and activities of each port. Each unit within the stack will also display the local port status.

Refer to the following table to interpret the port status mode LED.

TABLE 13 Port status mode (STAT) LED during normal operation

LED color	Status of hardware	Recommended action
Off	The port does not have a valid link.	None.
Steady green	The link is up and there is no traffic.	None.
Flashing green	The link is up and traffic/packets are transmitted or received.	None.
Steady amber	In Error or Out Error.	None. Clear stats CLI impacts the steady amber state, if no more error port moves out of the steady amber state.
Flashing amber	UDLD/LACP Blocking/ERR-DIS.	None.

Port speed status mode (SPD) LED

Port speed status (SPD) mode displays the speed setting of each downlink and uplink port (including modules).

Refer to the following table to interpret the port speed status mode LED.

TABLE 14 Port speed status (SPD) LED during normal operation

LED color	Status of hardware	Recommended action
Off	There is no valid link.	None.
Steady green	Highest speed.	None.
Flashing green	Second highest speed.	None.
Steady amber	Third highest speed.	None.
Flashing amber	Fourth highest speed.	None.
Alternating amber and green	Fifth highest speed.	None.

Member ID status mode (ID) LED

The member ID status mode (ID) LEDs display the Stack ID or SPX PE ID.

Stack ID: If the switch is configured in traditional stacking mode, this LED will display the stack member ID of the unit within the stack.

- Member ID LED lights Green.
- Port LEDs are used to display the stack ID from 1 to 12 of each member within the stack.

SPX PE ID: If the switch is configured in SPX mode, this LED will display the PE ID.

- Member ID LED lights Green.
- Port LEDs are used to display the PE ID from 17 to 56+ of each PE member.
- Two port LEDs will be used to display the ID: Steady green for the first digit and steady amber for the second digit.
- For example, LED for port #2 will show steady green and port #7 will show steady amber for PE ID #27. LED for port #3 will show steady green for 2 sec follow by a steady amber for 2 sec and continue to alternate green amber for PE ID #33. LED for port #4 will show steady green and port #10 will show steady amber for PE ID #40.

Refer to the following table to interpret the member ID status mode LED.

TABLE 15 Member ID status mode (ID) LED during normal operation

LED color	Status of hardware	Recommended action
Steady Green	Port number is the same as the stack ID. Or Port number is the first digit of PE ID.	None.
Steady amber	Port number is the second digit of PE ID. Or Port number is 10 and second digit or PE ID is 0.	None.
Alternating amber and green	First and second digit of PE ID are the same.	None.

USB status mode LED

Refer to the following tables to interpret the USB status mode LED.

TABLE 16 USB status mode LED when copying files from the system flash to the USB drive is enabled

LED color	Status of hardware	Recommended action
Steady green	USB is present and no operation in progress.	None.
Flashing green	Status mode selection button has been pressed for five seconds; the USB mode copy has started.	None.
Steady amber	USB is not detected.	None.
Flashing amber	Copy failure or application error or USB present but mount failure/access failure.	None.

TABLE 17 USB status mode LED when copying files from USB to the system flash is enabled

LED color	Status of hardware	Recommended action
Steady green	USB is plugged in or Auto-copy is complete.	None.
Flashing green	The flash upgrade is initiated.	None.
Steady amber	USB is not detected.	None.

Monitoring the Device

Interpreting port-side LEDs

TABLE 17 USB status mode LED when copying files from USB to the system flash is enabled (continued)

LED color	Status of hardware	Recommended action
Flashing amber	Copy failure or application error or USB present but mount failure/access failure/corrupt.	None.

PoE status mode LED (N/A for non-PoE)

PoE status mode displays the PoE status of each downlink port.

TABLE 18 PoE status mode LED during normal operation

LED color	Status of hardware	Recommended action
Off	PoE is disabled. Port is not providing PoE power.	None.
Steady green	PoE/PoE+/PoH is on. Port is providing power.	None.
Flashing amber	PoE is off due to a fault or not enough PoE power budget set for the port.	None.

Master/Slave status LED

Refer to the following table to interpret the master and slave status LED.

TABLE 19 Master/Slave status LED during normal operation

LED color	Status of hardware	Recommended action
Off	System is standalone or stack member or PE.	None.
Flashing green	This device is initializing as a stacking unit, and roles are being assigned.	None.
Flashing amber	The device is in non-operational mode; that is, stacking is enabled but the current unit is not able to join the stack due to a stack-related error condition such as image mismatch, configuration mismatch, or license mismatch. The device has lost its connection with the master unit.	None.
Steady green	Stacking mode is enabled and this device is the master unit in the stack or when the unit is standalone.	None.
Steady amber	Stacking mode is enabled and this device is a slave unit in the stack.	None.

Software update status LED

Refer to the following table to interpret the software update status LED.

TABLE 20 Software update status LED during normal operation

LED color	Status of hardware	Recommended action
Off	Software update is not enabled.	None.
Flashing green	Software installation is in progress and it can take up to 12 minutes.	None.
Steady green	Software auto-installation is successfully completed.	None.
Flashing amber	Device tried to boot up from last upgraded software image but could not, booting up from a different image or image upgrade failed	Contact Technical Support.

Diagnostics status LED

Refer to the following table to interpret the diagnostics status LED.

TABLE 21 Diagnostics status LED during normal operation

LED color	Status of hardware	Recommended action
Off	System is functioning normally or the device did not perform diagnostics test in the most recent reload.	None.
Flashing green	System self-diagnostic tests are in progress.	None.
Steady green	System self-diagnostic tests have successfully completed.	None.
Flashing amber	System self-diagnostic test has detected a fan, thermal, or interface fault.	<ul style="list-style-type: none"> Check the syslog messages details. Power cycle the device to try and clear the condition. If the condition persists, contact Technical Support.

Power status LED

Refer to the following table to interpret the system power status LED.

TABLE 22 System power status LED during normal operation

LED color	Status of hardware	Recommended action
Off	No power	<ul style="list-style-type: none"> Check if internal power supply is disconnected. Check the connections between the device, the power cord, and the wall outlet. Contact Technical Support.
Steady green	Internal power supply is working normally.	None.
Steady amber	Internal power supply for the PoE ports has failed.	Contact Technical Support.

OOB LED

Refer to the following table to interpret the OOB LED.

TABLE 23 Link status (Green): Left side LED

LED color	Hardware status	Recommended action
Off	Offline	None.
Steady green	Link is up.	None.
Flashing green	Packet transmission or reception is occurring at the port.	None.

TABLE 24 Speed status (Green): Right side LED

LED color	Hardware status	Recommended action
Off	Offline or linked at 10/100 Mbps.	None.
Steady green	Linked at 1000 Mbps.	None.

RJ-45 Ethernet port status LED in default mode

Refer to the following table to interpret individual RJ-45 Ethernet port status LED in default mode.

Monitoring the Device

Interpreting nonport-side LEDs

TABLE 25 Ethernet port status LED in default mode

LED color	Status of the hardware	Recommended action
Off	A link is not established with the remote port.	<ul style="list-style-type: none">• Verify that the connection to the other network device has been properly made. Also, make certain that the other network device is powered on and operating correctly.• Be sure the cable is plugged into both the device and the corresponding device.• Verify that the proper cable type is used and its length does not exceed specified limits.• Check the adapter on the attached device and cable connections for possible defects. Replace the defective adapter or cable if necessary.• Verify that the port has not been disabled through a configuration change. You can use the CLI. If you have configured an IP address on the device, you also can use the Web management interface or Brocade Network Advisor.• If the other actions do not resolve the problem, try using a different port or a different cable.
Steady green	The port has established a valid link at 1000 Mbps.	None.
Flashing green	The port has established a valid link at 1000 Mbps. Flashing indicates the port is transmitting and receiving user packets.	None.
Steady amber	The port has established a valid link at 10 or 100 Mbps.	None.
Flashing amber	The port has established a valid link at 10 or 100 Mbps. Flashing indicates the port is transmitting and receiving user packets.	None.

Interpreting nonport-side LEDs

There are no LEDs found on the nonport-side view of the Ruckus ICX 7150 devices.

Pinging an IP address

To verify that a device can reach another device through the network, enter a command similar to the following at any level of the CLI.

```
device> ping 10.33.4.7
```

NOTE

If you address the ping to the IP broadcast address, the device lists the first four responses.

Tracing a route

To determine the path through which a device can reach another device, enter a command similar to the following at any level of the CLI on the device.

```
device> traceroute 10.33.4.7
```

The CLI displays trace route information for each hop as soon as the information is received. Traceroute requests display all responses to a given TTL. In addition, if there are multiple equal-cost routes to the destination, the device displays up to two responses by default.

Digital optical monitoring

You can configure your device to monitor optical transceivers in the system, either globally or by specified port. When digital optical monitoring is enabled, the system monitors the temperature and signal power levels for the optical transceivers in the specified ports. Console messages and syslog messages are sent when optical operating conditions fall below or rise above the SFP and SFP+ manufacturer's recommended thresholds. For more information about digital optical monitoring, refer to the *Ruckus FastIron Monitoring Configuration Guide*.

Monitoring power and cooling

If the unit powers off after running for a while, check for loose power connections, power losses or surges at the power outlet, and use the **show chassis** command to verify that the temperature is below the shutdown threshold. If you still cannot isolate the problem, then the internal power supply may be defective. In this case, contact Brocade Technical Support for assistance.

The device contains temperature sensors that the software reads based on a configurable device poll time. The device has two automatic speed fan control settings based on the temperature. To protect the device from overheating, the following temperature threshold levels exist:

- The warning level is the temperature at which the device generates a syslog message. It is configurable up to 100°C (212°F).
- The shutdown level is the temperature at which the device reboots. It is set by the device and is not configurable. When the device temperature reaches the shutdown level, it generates a warning message that the device's temperature is over the shutdown level and the device shuts down in two minutes. The system restarts 120 seconds after the device reaches the temperature shutdown level.

The switch fans have two speeds, low and high. The fan speed settings are set by the device, and are not configurable. During system bootup, the fans run at high speed. After bootup, the fans operate at low speed when the temperature of the switch is below the high limit temperature that is specified in the following table. If the switch reaches the high limit temperature, the fans operate at high speed until the switch reaches the low limit temperature specified in the table, at which time the fans decrease to low speed. If the switch reaches or exceeds the critical (shutdown) temperature for two minutes, the switch shuts down.

NOTE

In addition to the overall temperature of the device, the PoE-supported models monitor the temperature of the Power over Ethernet (PoE) power supply unit (PSU). When the low limit and high limit temperatures are reached, the PoE PSU fans change speed using the same algorithm as the module fans. There is no change to the Critical (shutdown) temperature value for these modules.

TABLE 26 Temperature thresholds

Model	Low limit temperature	High limit temperature	Critical (shutdown) temperature
ICX 7150-C12P	Not applicable	Not applicable	109°C (228°F)
ICX 7150-24	Not applicable	Not applicable	105°C (221°F)
ICX 7150-24P	62°C (144°F) PoE PSU: 49°C (120°F)	72°C (162°F) PoE PSU: 57°C (135°F)	105°C (221°F)
ICX 7150-48	Not applicable	Not applicable	105°C (221°F)
ICX 7150-48P	60°C(140°F)	70°C(158°F)	105°C (221°F)

Monitoring the Device

Monitoring power and cooling

TABLE 26 Temperature thresholds (continued)

Model	Low limit temperature	High limit temperature	Critical (shutdown) temperature
	PoE PSU: 49°C (120°F)	PoE PSU: 57°C (135°F)	
ICX 7150-48PF	85°C (185°F) PoE PSU: 34°C (93°F)	95°C (203°F) PoE PSU: 41°C (106°F)	105°C (221°F)
ICX 7150-48ZP	85°C (185°F) PoE PSU: 34°C (93°F)	95°C (203°F) PoE PSU: 41°C (106°F)	105°C (221°F)

To display the temperature of a device, enter the **show chassis** command at any level of the CLI. The **show chassis** command displays the current temperature, the power supply status, and temperature threshold levels. The displayed temperature reflects the temperature of the board inside the device.

```
device# show chassis
The stack unit 1 chassis info:

Power supply 1 (AC - PoE) present, status ok
  Model Number:   YM-1921AB06R
  Serial Number:  SA000V171708000081
  Firmware Ver:   P2H802A00
Power supply 1 Fan Air Flow Direction: Front to Back
Power supply 2 (AC - PoE) present, status ok
  Model Number:   YM-1921AB06R
  Serial Number:  SA000V171708000083
  Firmware Ver:   P2H802A00
Power supply 2 Fan Air Flow Direction: Front to Back

Fan 1 ok, speed (manual): 1<->[[2]]
Fan 2 ok, speed (manual): 1<->[[2]]

Fan controlled temperature:
  Rule 1/2 (MGMT THERMAL PLANE): 60.7 deg-C
  Rule 2/2 (PoE THERMAL PLANE): 10.0 deg-C

Fan speed switching temperature thresholds:
  Rule 1/2 (MGMT THERMAL PLANE):
    Speed 1: NM<----->95          deg-C
    Speed 2: 85<----->105 deg-C (shutdown)
  Rule 2/2 (PoE THERMAL PLANE):
    Speed 1: NM<----->41          deg-C
    Speed 2: 34<----->105 deg-C (shutdown)

Fan 1 Air Flow Direction: Front to Back
Fan 2 Air Flow Direction: Front to Back
Slot 1 Current Temperature: 61.7 deg-C (Sensor 1), 54.4 deg-C (Sensor 2), 10.0 deg-C (Sensor 3)
Slot 2 Current Temperature: NA
  Warning level.....: 102.0 deg-C
  Shutdown level.....: 105.0 deg-C
Boot Prom MAC : 609c.9fe2.154c
Management MAC: 609c.9fe2.08d6
```

Ruckus ICX 7150 Switch Technical Specifications

This content highlights the features and specifications for the Ruckus ICX 7150 switch.

System specifications

System component	Description
Enclosure	1U; 19-inch rack-mountable; desktop-, wall-, under-desk-, or magnet-mountable
Power inlet	C14 for AC power
Power supplies	Integrated AC power supply for system and PoE power Dual modular power supplies for ICX7150-48ZP
Fans	Fanless devices <ul style="list-style-type: none">• ICX 7150-C12P• ICX 7150-24• ICX 7150-48 Two integrated fans per device. 150 W maximum PoE budget in fanless mode. <ul style="list-style-type: none">• ICX 7150-24P• ICX 7150-48P Two modular fan trays and two modular power supplies, each of which has a fan <ul style="list-style-type: none">• ICX 7150-48ZP Three integrated fans per device. Fanless mode is not supported. <ul style="list-style-type: none">• ICX 7150-48PF
Cooling	Closed airflow <ul style="list-style-type: none">• ICX 7150-C12P• ICX 7150-24• ICX 7150-48 Side-to-back airflow <ul style="list-style-type: none">• ICX 7150-24P• ICX 7150-48P• ICX 7150-48PF• ICX 7150-48ZP
System architecture	Edge Ethernet switches with full duplex switching and forwarding capabilities <ul style="list-style-type: none">• 10/100/1000 Mbps RJ-45 downlink and uplink ports• 100/1000M/2.5 Gbps RJ-45 downlink ports (ICX7150-48ZP only)• PoE+ chipsets with two pair power up to Class 4 power levels of 30 W• UPoE/PoH chipsets with four pair power up to 90 W (ICX7150-48ZP only)• Optical SFP+ uplink and stacking ports

Ethernet

System component	Description
Ethernet ports	<p>ICX 7150-48ZP: Sixteen 2.5G and thirty-two 1G Copper ports with eight SFP+ 1G/10-GbE optical stacking or uplink ports</p> <p>ICX 7150-C12P: Twelve RJ-45 GbE with 802.3at PoE+, two RJ-45 GbE uplink, two SFP+ 10-GbE uplink/stacking</p> <p>ICX 7150-24: Twenty-four RJ-45 GbE, two RJ-45 GbE uplink, four SFP+ 10-GbE uplink/stacking</p> <p>ICX 7150-24P: Twenty-four RJ-45 GbE with 802.3at PoE+, two RJ-45 GbE uplink, four SFP+ 10-GbE uplink/stacking</p> <p>ICX 7150-48: Forty-eight RJ-45 GbE, two RJ-45 GbE uplink, four SFP+ 10-GbE uplink/stacking</p> <p>ICX 7150-48P: Forty-eight RJ-45 GbE with 802.3at PoE+, two RJ-45 GbE uplink, four SFP+ 10-GbE uplink/stacking</p> <p>ICX 7150-48PF: Forty-eight RJ-45 GbE with 802.3at PoE+, two RJ-45 GbE uplink, four SFP+ 10-GbE uplink/stacking</p>
Management interface	<p>One 10/100/1000 Mbps Ethernet, out-of-band management interface (RJ-45 port) per device</p> <p>One Type-C USB console port per device</p> <p>One RJ-45 console port per device</p>

LEDs

System component	Description
System status LEDs	<p>SYST: Bicolor LED (green/yellow) controlled by software to indicate the system status</p> <p>M/S: Bicolor LED (green/yellow) controlled by software to indicate master/slave status in stacking mode</p> <p>UPDATE: Bicolor LED (green/yellow) controlled by software to indicate the DHCP auto-configuration from DHCP server</p> <p>DIAG: Bicolor LED (green/yellow) controlled by software to indicate the system is in diagnostic mode</p> <p>CLD: Bicolor LED (green/yellow) controlled by software to indicate the connection to the cloud services platform</p> <p>PWR: Bicolor LED (green/yellow) indicates the internal power status</p>
Port status mode selection LEDs (not enabled currently)	<p>STAT: Bicolor LED (green/yellow) controlled by software to indicate link status</p> <p>SPD: Bicolor LED (green/yellow) controlled by software to indicate link speed</p> <p>(Stacking) ID: Port LED (green) to display stacking ID from 1 to 12</p> <p>USB: Bicolor LED (green/yellow) to indicate USB flash / Show Tech / file copy / boot status</p> <p>POE: Bicolor LED (green/yellow) controlled by software to indicate PoE/PoE+</p>
Port status LEDs	<p>RJ-45 link status LED: Indicates Ethernet link status and speed</p> <p>SFP/SFP+ status LED: Indicates link status and speed for SFP or SFP+ ports</p> <p>Out-of-band management port: Two single-color LEDs indicate out-of-band management port link status and speed</p>

Other

System component	Description
STATUS MODE	Port status mode selection button
RESET	Reset button for hardware reset without power cycling. There is a hole in the front panel to allow access.
USB port	Standard type-A USB connector for removable media
Console connectors	RJ-45 console connector USB console Type-C connector
RJ-45 connectors	RJ-45 connectors for GbE data ports

Weight and physical dimensions

The **Total weight** column includes the weight of the unit and the contents of the shipping carton.

Model	Height	Width	Depth	Unit weight	Total weight
ICX 7150-48ZP	4.37 cm	44.0 cm	33.2 cm	6.246 kg	8.282 kg
With one power supply and one fan	1.72 in	17.32 in	13.1 in	13.770 lb	18.259 lb
ICX 7150-48ZP	4.37 cm	44.0 cm	33.2 cm	7.415 kg	9.451 kg
With two power supplies and two fans	1.72 in	17.32 in	13.1 in	16.347 lb	20.836 lb
ICX 7150-C12P	4.37 cm	26.9 cm	21.3 cm	2.58 kg	3.12 kg
	1.72 in	10.59 in	8.39 in	5.69 lb	6.88 lb
ICX 7150-24	4.37 cm	44.0 cm	28.0 cm	3.80 kg	5.20 kg
	1.72 in	17.32 in	11.0 in	8.38 lb	11.46 lb
ICX 7150-24P	4.37 cm	44.0 cm	28.0 cm	4.93 kg	6.35 kg
	1.72 in	17.32 in	11.0 in	10.97 lb	14.00 lb
ICX 7150-48	4.37 cm	44.0 cm	37.0 cm	4.82 kg	6.65 kg
	1.72 in	17.32 in	14.6 in	10.63 lb	14.66 lb
ICX 7150-48P	4.37 cm	44.0 cm	37.0 cm	6.17 kg	7.90 kg
	1.72 in	17.32 in	14.6 in	13.60 lb	17.42 lb
ICX 7150-48PF	4.37 cm	44.0 cm	37.0 cm	6.28 kg	8.07 kg
	1.72 in	17.32 in	14.6 in	13.85 lb	17.79 lb

Environmental requirements

Condition	Operational	Non-operational
Ambient temperature	-5°C (cold start), 0°C to 45°C (23°F to 113°F) at sea level. ¹	-25°C to 70°C (-13°F to 158°F)
Relative humidity (non-condensing)	5% to 95% at 45°C (113°F)	0% to 95% at 70°C (158°F)
Altitude (above sea level)	0 to 3,000 m (10,000 feet)	0 to 12,000 m (39,000 feet)

Ruckus ICX 7150 Switch Technical Specifications

Power supply specifications (per PSU)

Condition	Operational	Non-operational
Shock	20 G, 11 ms, half-sine wave	33 G, 11 ms, half-sine wave
Vibration	1 G sine, 0.4 gms random, 5-500 Hz	2.4 G sine, 1.1 gms random, 5-500 Hz
Airflow	ICX 7150-48ZP: 40.36 CFM (Maximum), 14.6 CFM (Typical) ICX 7150-C12P: 0 CFM ICX 7150-24: 0 CFM ICX 7150-24P: 37.6 CFM (Maximum), 13.4 CFM (Typical) ICX 7150-48: 0 CFM ICX 7150-48P: 38.15 CFM (Maximum), 13.9 CFM (Typical) ICX 7150-48PF: 50.8 CFM (Maximum), 19.6 CFM (Typical)	N/A
Heat dissipation	Refer to Power Consumption specification sections	N/A
Operating noise	For all fanless ICX 7150 devices and devices in fanless mode: Less than 12 dBA ICX 7150-24P, ICX 7150-48P, and ICX 7150-48ZP with fans running: Maximum of 52 dBA ICX 7150-48PF with fans running: Maximum of 48 dBA (fanless mode is not supported)	N/A

Power supply specifications (per PSU)

All the Ruckus ICX 7150 power supply units (PSUs) are fixed and internal to the device. All the PSUs use a C14 inlet and connect to standard AC power.

Device	Maximum output power rating (DC)	Input voltage	Input line frequency	Maximum input current	Input line protection	Maximum inrush current
ICX 7150-48ZP	1740 W	100 - 240 VAC (nominal) 90 - 264 VAC (range)	50/60 Hz (nominal) 47 - 63 Hz (range)	13 A (rms)	Line fused	30 A at 115 VAC 60 A at 230 VAC Cold start @ 25°C
ICX 7150-C12P	150 W	100 - 240 VAC (nominal) 90 - 264 VAC (range)	50/60 Hz (nominal) 47 - 63 Hz (range)	2.78 A (rms)	Line fused	40 A at 115 VAC 60 A at 230 VAC Cold start @ 25°C
ICX 7150-24	36 W	100 - 240 VAC (nominal) 90 - 264 VAC (range)	50/60 Hz (nominal) 47 - 63 Hz (range)	3 A (rms)	Line fused	40 A at 115 VAC 80 A at 230 VAC Cold start @ 25°C

¹ For the ICX 7150-C12P, the maximum operating temperature is 40°C when under fully loaded PoE conditions or when installed using the long bracket (ICX7000-C12-RMK) under a fixed surface. The maximum operating temperature is 35°C when installed using the short bracket (ICX7000-C12-WMK) under a fixed surface.

Device	Maximum output power rating (DC)	Input voltage	Input line frequency	Maximum input current	Input line protection	Maximum inrush current
ICX 7150-24P	525 W	100 - 240 VAC (nominal) 90 - 264 VAC (range)	50/60 Hz (nominal) 47 - 63 Hz (range)	7.23 A (rms)	Line fused	30 A at 115 VAC 60 A at 230 VAC Cold start @ 25°C
ICX 7150-48	65 W	100 - 240 VAC (nominal) 90 - 264 VAC (range)	50/60 Hz (nominal) 47 - 63 Hz (range)	5.4 A (rms)	Line fused	40 A at 115 VAC 80 A at 230 VAC Cold start @ 25°C
ICX 7150-48P	525 W	100 - 240 VAC (nominal) 90 - 264 VAC (range)	50/60 Hz (nominal) 47 - 63 Hz (range)	11.25 A (rms)	Line fused	30 A at 115 VAC 60 A at 230 VAC Cold start @ 25°C
ICX 7150-48PF	880 W	100 - 240 VAC (nominal) 90 - 264 VAC (range)	50/60 Hz (nominal) 47 - 63 Hz (range)	14.45 A (rms)	Line fused	60 A at 115 VAC 120 A at 230 VAC Cold start @ 25°C

Power consumption (idle configuration)

Idle: No optics or connections to ports installed and system booted up. Fans at nominal speed.

Model name	@100 VAC input	@200 VAC input	@-48 VDC input	Minimum number of power supplies	Notes
ICX 7150-48ZP With one power supply and one fan	0.82 A 89 W 303.68 BTU/hr	0.5 A 85.89 W 293.07 BTU/hr	N/A	1	All ports down, no optics or cables connected. No Load (traffic)
ICX 7150-48ZP With two power supplies and two fans	1.14 A 108 W 368.51 BTU/hr	0.7 A 105.4 W 359.64 BTU/hr	N/A	2	All ports down, no optics or cables connected. No Load (traffic)
ICX 7150-C12P	0.22 A 20.10 W 68.60 BTU/hr	0.16 A 19.5 W 68.09 BTU/hr	N/A	1	All ports down, no optics or cables connected. No Load (traffic)
ICX 7150-24	0.25 A 13.88 W 47.37 BTU/hr	0.16 A 13.53 W 46.18 BTU/hr	N/A	1	All ports down, no optics or cables connected. No Load (traffic)
ICX 7150-24P	0.35 A 31.58 W 107.79 BTU/hr	0.29 A 30.64 W 104.58 BTU/hr	N/A	1	All ports down, no optics or cables connected. No Load (traffic)

Ruckus ICX 7150 Switch Technical Specifications
Power consumption (typical configuration)

Model name	@100 VAC input	@200 VAC input	@-48 VDC input	Minimum number of power supplies	Notes
ICX 7150-48	0.46 A 24.19 W 82.56 BTU/hr	0.28 A 23.55 W 80.38 BTU/hr	N/A	1	All ports down, no optics or cables connected. No Load (traffic)
ICX 7150-48P	0.50 A 46.90 W 160.07 BTU/hr	0.35 A 46.80 W 159.73 BTU/hr	N/A	1	All ports down, no optics or cables connected. No Load (traffic)
ICX 7150-48PF	0.53 A 49.90 W 170.31 BTU/hr	0.37 A 49.33 W 168.37 BTU/hr	N/A	1	All ports down, no optics or cables connected. No Load (traffic) Fans always running.

Power consumption (typical configuration)

Typical: 10% traffic rate on all ports with 64-byte packet size and random payload at room temperature. All ports fully configured. Fans at nominal speed.

Model name	@100 VAC input	@200 VAC input	@-48 VDC input	Minimum number of power supplies	Notes
ICX 7150-48ZP With one power supply and one fan	9.29 A 917 W 3218.935 BTU/hr	4.41 A 870 W 2968.56 BTU/hr	N/A	1	All 2.5G and 1G ports and eight 10G ports are linked UP 10% traffic 100% PoE Load @ Class 3 (15.4W per port, Total 740W)
ICX 7150-48ZP With two power supplies and two fans	18.29 A 1804 W 6155.5 BTU/hr	8.63 A 1868 W 5752,87 BTU/hr	N/A	2	All 2.5G and 1G ports and eight 10G ports are linked UP 10% traffic 100% PoE Load @ Class 3 (15.4W per port, Total 740W)
ICX 7150-C12P	1.59 A 157.12 W 536.26 BTU/hr	0.80 A 153.31 W 523.26 BTU/hr	N/A	1	12 1-GbE and 2 10-GbE ports are linked UP ONLY. 10% traffic. 100% PoE Load @ Class 3 (15.4 W/port)
ICX 7150-24	0.42 A 23.87 W 81.47 BTU/hr	0.26 A 23.37 W 76.76 BTU/hr	N/A	1	24 1-GbE and 4 10-GbE ports are linked UP ONLY. 10% traffic.

Model name	@100 VAC input	@200 VAC input	@-48 VDC input	Minimum number of power supplies	Notes
ICX 7150-24P	4.57 A 455.39 W 1554.28 BTU/hr	2.24 A 438.75 W 1497.49 BTU/hr	N/A	1	24 1-GbE and 4 10-GbE ports are linked UP ONLY. 10% traffic. 100% PoE Load @ Class 3 (15.4 W/port)
ICX 7150-48	0.74 A 38.49 W 131.37 BTU/hr	0.45 A 39.02 W 133.18 BTU/hr	N/A	1	48 1-GbE and 4 10-GbE ports are linked UP ONLY. 10% traffic.
ICX 7150-48P	4.88 A 476.30 W 1625.65 BTU/hr	2.35 A 460.60 W 1572.06 BTU/hr	N/A	1	48 1-GbE and 4 10-GbE ports are linked UP ONLY. 10% traffic. 100% PoE Load @ Class 3 (15.4 W/port)
ICX 7150-48PF	9.56 A 922.0 W 3146.86 BTU/hr	4.45 A 868.54 W 2964.40 BTU/hr	N/A	1	48 1-GbE and 4 10-GbE ports are linked UP ONLY. 10% traffic. 100% PoE Load @ Class 3 (15.4 W/port)

Power consumption (maximum configuration)

Maximum: All ports fully configured with connection and traffic at maximum throughput. Fans at high speed.

Model name	@100 VAC input	@200 VAC input	@-48 VDC input	Minimum number of power supplies	Notes
ICX 7150-48ZP With one power supply and one fan	9.46 A 932 W 3180.12 BTU/hr	4.54 A 888 W 3029.98 BTU/hr	N/A	1	All 2.5G and 1G ports and eight 10G ports are linked UP 100% traffic 100% PoE Load @ Class 3 (15.4W per port, Total 740W) Fan at high speed
ICX 7150-48ZP With two power supplies and two fans	18.66 A 1841 W 6281.75 BTU/hr	8.8 A 1720 W 5868.88 BTU/hr	N/A	2	All 2.5G and 1G ports and eight 10G ports are linked UP 100% traffic 100% PoE Load @ Class 3 (15.4W per port, Total 740W) Fans at high speed

Ruckus ICX 7150 Switch Technical Specifications
Data port specifications (Ethernet)

Model name	@100 VAC input	@200 VAC input	@-48 VDC input	Minimum number of power supplies	Notes
ICX 7150-C12P	1.59 A 157.21 W 536.57 BTU/hr	0.80 A 153.39 W 523.53 BTU/hr	N/A	1	12 1-GbE and 2 10-GbE ports are linked UP ONLY. 100% traffic. 100% PoE Load @ Class 3 (15.4 W/port)
ICX 7150-24	0.42 A 23.96 W 81.78 BTU/hr	0.27 A 24.19 W 82.56 BTU/hr	N/A	1	24 1-GbE and 4 10-GbE ports are linked UP ONLY. 100% traffic.
ICX 7150-24P	4.74 A 471.85 W 1610.46 BTU/hr	2.32 A 454.62 W 1551.65 BTU/hr	N/A	1	24 1-GbE and 4 10-GbE ports are linked UP ONLY. 100% traffic. 100% PoE Load @ Class 3 (15.4 W/port)
ICX 7150-48	0.74 A 38.78 W 132.36 BTU/hr	0.46 A 39.14 W 133.59 BTU/hr	N/A	1	48 1-GbE and 4 10-GbE ports are linked UP ONLY. 100% traffic.
ICX 7150-48P	5.03 A 491.32 W 1676.91 BTU/hr	2.42 A 475.0 W 1621.21 BTU/hr	N/A	1	48 1-GbE and 4 10-GbE ports are linked UP ONLY. 10% traffic. 100% PoE Load @ Class 3 (15.4 W/port)
ICX 7150-48PF	9.82 A 949.33 W 3240.14 BTU/hr	4.57 A 893.30 W 3048.90 BTU/hr	N/A	1	48 1-GbE and 4 10-GbE ports are linked UP ONLY. 10% traffic. 100% PoE Load @ Class 3 (15.4 W/port)

Data port specifications (Ethernet)

NOTE

The ICX 7150 10-GbE ports provide both active and passive cable support.

Model	Port type	Number of ports	Description
ICX 7150-48ZP	1 GbE (copper)	48 downlink	RJ-45 10/100/1000 Mbps ports
	2.5 GbE (copper)	16 downlink	RJ-45 100/1000 M/2.5 Gbps ports
	1/10 GbE (optical)	4 uplink and 4 stacking	SFP+ ports
ICX 7150-C12P	GbE (copper)	12 downlink + 2 uplink	RJ-45 10/100/1000 Mbps ports
	10 GbE (optical)	2 uplink or stacking	SFP+ ports
ICX 7150-24	GbE (copper)	24 downlink + 2 uplink	RJ-45 10/100/1000 Mbps ports

Model	Port type	Number of ports	Description
ICX 7150-24P	10 GbE (optical)	4 uplink or stacking	SFP+ ports
	GbE (copper)	24 downlink + 2 uplink	RJ-45 10/100/1000 Mbps ports
	10 GbE (optical)	4 uplink or stacking	SFP+ ports
ICX 7150-48	GbE (copper)	48 downlink + 2 uplink	RJ-45 10/100/1000 Mbps ports
	10 GbE (optical)	4 uplink or stacking	SFP+ ports
ICX 7150-48P	GbE (copper)	48 downlink + 2 uplink	RJ-45 10/100/1000 Mbps ports
	10 GbE (optical)	4 uplink or stacking	SFP+ ports
ICX 7150-48PF	GbE (copper)	48 downlink + 2 uplink	RJ-45 10/100/1000 Mbps ports
	10 GbE (optical)	4 uplink or stacking	SFP+ ports

Serial port specifications (pinout RJ-45)

Pin	Signal	Description
1	Not supported	N/A
2	Not supported	N/A
3	UART1_TXD	Transmit data
4	GND	Logic ground
5	GND	Logic ground
6	UART1_RXD	Receive data
7	Not supported	N/A
8	Not supported	N/A

Serial port specifications (protocol)

Parameter	Value
Baud	9600 bps
Data bits	8
Parity	None
Stop bits	1
Flow control	None

Memory specifications

Memory	Type	Size
Boot Flash	SPI NOR Flash	2 x 8 MB
Compact Flash	NAND Flash (MLC)	2 GB
Main Memory	DDR4 SDRAM (not ECC capable)	1 GB

Regulatory compliance (EMC)

- FCC Part 15, Subpart B
- EN 55024
- EM 55032 (CE Mark) (Class A)
- ICES-003
- VCCI
- EN 300 386
- CNS 13438
- KN 32
- KN 35
- TCVN 7189
- EN 61000-3-2
- EN 61000-3-3
- GB 9254
- CISPR 32
- 2014/30/EU
- AS/NZS CISPR32 (Australia) (Class A)

Regulatory compliance (safety)

- EN/UL 60825
- EN/UL/CSA/IEC 60950-1
- GB 4943.1
- CNS 14336-1
- 2014/35/EU

Regulatory compliance (environmental)

- 2011/65/EU - Restriction of the use of certain hazardous substance in electrical and electronic equipment (EU RoHS).
- 2012/19/EU - Waste electrical and electronic equipment (EU WEEE).
- 94/62/EC - packaging and packaging waste (EU).
- 2006/66/EC - batteries and accumulators and waste batteries and accumulators (EU battery directive).
- 1907/2006 of the European Parliament and of the Council of 18 December 2006 concerning the Registration, Evaluation, Authorisation and Restriction of Chemicals (EU REACH).
- Section 1502 of the Dodd-Frank Wall Street Reform and Consumer Protection Act of 2010 - U.S. Conflict Minerals.
- 30/2011/TT-BCT - Vietnam circular.
- SJ/T 11363-2006 Requirements for Concentration Limits for Certain Hazardous Substances in EIPs (China).
- SJ/T 11364-2006 Marking for the Control of Pollution Caused by EIPs (China).

Regulatory Statements

• CE statement.....	111
• China ROHS.....	111
• BSMI statement (Taiwan).....	111
• Canadian requirements.....	112
• China CCC statement.....	112
• Europe and Australia (CISPR 32 Class A Warning).....	113
• FCC warning (US only).....	113
• Germany statement.....	113
• KCC statement (Republic of Korea).....	113
• VCCI statement.....	113

CE statement

ATTENTION

This is a Class A product. In a domestic environment, this product might cause radio interference, and the user might be required to take corrective measures.

The standards compliance label on this device contains the CE mark which indicates that this system conforms to the provisions of the following European Council directives, laws, and standards:

- Electromagnetic Compatibility (EMC) Directive 2014/30/EU
- Low Voltage Directive (LVD) 2014/35/EU
- EN 55032/EN 55024 (European Immunity Requirements)
 - EN61000-3-2/JEIDA (European and Japanese Harmonics Spec)
 - EN61000-3-3

China ROHS

Refer to the latest revision of the China ROHS document (P/N 53-1000428-xx) which ships with the product.

BSMI statement (Taiwan)

警告使用者：

這是甲類的資訊產品，在居住的環境中使用時，可能會造成射頻干擾，
在這種情況下，使用者會被要求採取某些適當的對策。

Warning:

This is Class A product. In a domestic environment this product may cause radio interference in which case the user may be required to take adequate measures.

Canadian requirements

This Class A digital apparatus meets all requirements of the Canadian Interference-Causing Equipment Regulations, ICES-003 Class A.
Cet appareil numérique de la classe A est conforme à la norme NMB-003 du Canada.

China CCC statement



China-CCC Warning statements

在维修的时候一定要断开所有电源 (English translation "disconnect all power sources before service")



For non tropical use:

安全 说明 和标 记	汉文	“仅适用于非热带气候条件下安全使用。”
	藏文	《非热带气候条件下安全使用。》
	蒙古文	“非热带气候条件下安全使用。”
	壮文	Dan hab yungh youq gij dienheiq diuzgen mbouj dwg diegndat haenx ancienz sawjyung.
	维文	غەيرى ئىسسىق بەلباغ ھاۋا كىلىماتى شارا ئىتتىدىلا بىخەتەر ئىشلەتكىلى بولىدۇ



For altitude 2000 meter and below:

安全 说明 和标 记	汉文	仅适用于海拔2000m以下地区安全使用。
	藏文	《2000m 以下地区安全使用。》
	蒙古文	“2000m 以下地区安全使用。”
	壮文	Dan hab yungh youq gij digih haijbaz 2000m doxroengz haenx ancienz sawjyung.
	维文	دېڭىز يۈزىدىن 2000 مېتر تۆۋەن رايونلاردا بىخەتەر ئىشلەتكىلى بولىدۇ

Warning for Class A:

声明
此产品为A级产品，在生活环境中，该产品可能会造成无线电干扰。在这种情况下，可能需要用户对干扰采取切实可行的措施。

English translation of above statement

This is a Class A product. In a domestic environment this product may cause radio interference, in which case the user may be required to take adequate measures.

Europe and Australia (CISPR 32 Class A Warning)

This is a Class A product. In a domestic environment this product may cause radio interference in which case the user may be required to take adequate measures.

FCC warning (US only)

This equipment has been tested and complies with the limits for a Class A computing device pursuant to Part 15 of the FCC Rules. These limits are designed to provide reasonable protection against harmful interference when the equipment is operated in a commercial environment.

This equipment generates, uses, and can radiate radio frequency energy, and if not installed and used in accordance with the instruction manual, might cause harmful interference to radio communications. Operation of this equipment in a residential area is likely to cause harmful interference, in which case the user will be required to correct the interference at the user's own expense.

Germany statement

Machine noise information regulation - 3. GPSGV, the highest sound pressure level value is 70.0 dB(A) in accordance with EN ISO 7779.

Maschinenlärminformations-Verordnung - 3. GPSGV, der höchste Schalldruckpegel beträgt 70.0 dB(A) gemäß EN ISO 7779.

KCC statement (Republic of Korea)

A급 기기 (업무용 방송통신기기): 이 기기는 업무용(A급)으로 전자파적합등록을 한 기기이오니 판매자 또는 사용자는 이 점을 주의하시기 바라며, 가정외의 지역에서 사용하는 것을 목적으로 합니다.

Class A device (Broadcasting Communication Device for Office Use): This device obtained EMC registration for office use (Class A), and may be used in places other than home. Sellers and/or users need to take note of this.

VCCI statement

この装置は、クラスA情報技術装置です。この装置を家庭環境で使用すると電波妨害を引き起こすことがあります。この場合には使用者が適切な対策を講ずるよう要求されることがあります。 VCCI-A

This is a Class A product based on the standard of the Voluntary Control Council for Interference by Information Technology Equipment (VCCI). If this equipment is used in a domestic environment, radio disturbance might arise. When such trouble occurs, the user might be required to take corrective actions.

Cautions and Danger Notices

- Cautions.....115
- Danger Notices..... 118

Cautions

A Caution statement alerts you to situations that can be potentially hazardous to you or cause damage to hardware, firmware, software, or data.

Ein Vorsichtinweis warnt Sie vor potenziellen Personengefahren oder Beschädigung der Hardware, Firmware, Software oder auch vor einem möglichen Datenverlust

Un message de mise en garde vous alerte sur des situations pouvant présenter un risque potentiel de dommages corporels ou de dommages matériels, logiciels ou de perte de données.

Un mensaje de precaución le alerta de situaciones que pueden resultar peligrosas para usted o causar daños en el hardware, el firmware, el software o los datos.

General cautions



CAUTION

Changes or modifications made to this device that are not expressly approved by the party responsible for compliance could void the user's authority to operate the equipment.

VORSICHT	Falls dieses Gerät verändert oder modifiziert wird, ohne die ausdrückliche Genehmigung der für die Einhaltung der Anforderungen verantwortlichen Partei einzuholen, kann dem Benutzer der weitere Betrieb des Gerätes untersagt werden.
MISE EN GARDE	Les éventuelles modifications apportées à cet équipement sans avoir été expressément approuvées par la partie responsable d'en évaluer la conformité sont susceptibles d'annuler le droit de l'utilisateur à utiliser cet équipement.
PRECAUCIÓN	Si se realizan cambios o modificaciones en este dispositivo sin la autorización expresa de la parte responsable del cumplimiento de las normas, la licencia del usuario para operar este equipo puede quedar anulada.



CAUTION

Do not install the device in an environment where the operating ambient temperature might exceed 45°C (113°F).

VORSICHT	Das Gerät darf nicht in einer Umgebung mit einer Umgebungsbetriebstemperatur von über 45°C (113°F) installiert werden.
MISE EN GARDE	N'installez pas le dispositif dans un environnement où la température d'exploitation ambiante risque de dépasser 45°C (113°F).
PRECAUCIÓN	No instale el instrumento en un entorno en el que la temperatura ambiente de operación pueda exceder los 45°C (113°F).



CAUTION

Make sure the airflow around the front, and back of the device is not restricted.

VORSICHT	Stellen Sie sicher, dass an der Vorderseite, den Seiten und an der Rückseite der Luftstrom nicht behindert wird.
MISE EN GARDE	Vérifiez que rien ne restreint la circulation d'air devant, derrière et sur les côtés du dispositif et qu'elle peut se faire librement.
PRECAUCIÓN	Asegúrese de que el flujo de aire en las inmediaciones de las partes anterior, laterales y posterior del instrumento no esté restringido.

Cautions and Danger Notices

Cautions



CAUTION

Never leave tools inside the chassis.

VORSICHT	Lassen Sie keine Werkzeuge im Chassis zurück.
MISE EN GARDE	Ne laissez jamais d'outils à l'intérieur du châssis
PRECAUCIÓN	No deje nunca herramientas en el interior del chasis.



CAUTION

To protect the serial port from damage, keep the cover on the port when not in use.

VORSICHT	Um den seriellen Anschluss vor Beschädigungen zu schützen, sollten Sie die Abdeckung am Anschluss belassen, wenn er nicht verwendet wird.
MISE EN GARDE	Mettre le bouchon de protection sur le port série lorsqu'il ne sert pas pour éviter de l'endommager.
PRECAUCIÓN	Para evitar que se dañe el puerto serie, mantenga la cubierta colocada sobre el puerto cuando no lo utilice.



CAUTION

Before mounting the device using the magnet sheet, make sure the rubber feet are not installed on the device to ensure that the magnet sheet holds on to the device strongly and does not detach. If the rubber feet are already installed, remove them first before attaching the magnet sheet.

VORSICHT	Die GummifüÙe sollten vor dem Anbringen des Geräts mittels der Magnetplatte noch nicht montiert sein. So stellen Sie sicher, dass die Magnetplatte fest am Gerät sitzt und sich nicht löst. Wenn die GummifüÙe bereits montiert sind, entfernen Sie diese vor dem Anbringen der Magnetplatte.
MISE EN GARDE	Avant d'installer l'appareil en utilisant la feuille magnétique, assurez-vous que les pieds en caoutchouc ne sont pas installés sur l'appareil pour s'assurer que la feuille magnétique tient fermement sur l'appareil et ne se détache pas. Si les pieds en caoutchouc sont déjà installés, les enlever d'abord avant de fixer la feuille magnétique.
PRECAUCIÓN	Antes de montar el dispositivo mediante el uso la lámina magnetica asegúrese de que las bases de goma no estén instaladas sobre el dispositivo para garantizar que la lámina magnetica se adhiera al dispositivo con firmeza y no se desprenda. Si las bases de goma ya están instaladas, primero remuevalas antes de colocar la lámina magnetica.



CAUTION

The magnet sheet can only be placed against the bottom panel of the device. Do not attempt to attach the magnet sheet to any other panels on the device.

VORSICHT	Die magnetische Matte kann nur an der Unterseite des Geräts angebracht werden. Versuchen Sie nicht, die magnetische Matte an den anderen Seiten des Geräts anzubringen.
MISE EN GARDE	Il est uniquement possible de placer la feuille magnétique contre la face inférieure du dispositif. Ne tentez pas de placer la feuille magnétique à d'autres endroits.
PRECAUCIÓN	La hoja magnética solo se puede colocar sobre el panel inferior del dispositivo. No intente conectar la hoja magnética a ningún otro panel del dispositivo.



CAUTION

Do not mount the device on a surface with the top panel facing downward. Mount the device only on a vertical metal surface with the front panel port-side facing downward.

VORSICHT	Montieren Sie das Gerät nicht mit der Oberseite nach unten auf einer Oberfläche. Montieren Sie das Gerät nur mit der Vorderseite (portseitig) nach unten auf einer vertikalen Metalloberfläche.
MISE EN GARDE	N'installez pas l'appareil avec le panneau supérieur faisant face vers le bas. Pour un montage vertical, installez l'appareil sur une surface métallique avec le panneau avant (côté ports) faisant face vers le bas.
PRECAUCIÓN	No instale el dispositivo sobre una superficie con el panel superior mirando hacia abajo. Instale el dispositivo solamente sobre una superficie metálica vertical con el panel frontal de los puertos de usuario orientado hacia abajo.



CAUTION

Ensure that the metal surface is flat and the texture is smooth to hold the device strongly. Check for other conditions that might impede secure magnetic mount.

VORSICHT	Achten Sie darauf, dass die Metalloberfläche eben und glatt ist, damit das Gerät sicher montiert werden kann. Prüfen Sie andere Bedingungen, die eine sichere magnetische Montage beeinflussen könnten.
MISE EN GARDE	Assurez-vous que la surface métallique est plane et lisse afin de maintenir l'appareil fermement en place. Vérifiez qu'il n'y a pas d'autres conditions qui pourraient nuire à une installation sécuritaire.
PRECAUCIÓN	Asegúrese de que la superficie metálica sea plana y de que la textura sea pareja para sostener el dispositivo con firmeza. Esté atento a otras condiciones que puedan impedir una instalación segura del montaje magnético.



CAUTION

When mounting the device under a fixed surface, under a desk, or under a shelf, use the long brackets to provide adequate ventilation and not exceed the operating temperature.

VORSICHT	Wenn Sie das Gerät unter einer festen Oberfläche, einem Tisch oder einem Regal montieren, verwenden Sie die langen Halterungen, um für eine angemessene Belüftung zu sorgen und die Betriebstemperatur nicht zu überschreiten.
MISE EN GARDE	Lors du montage de l'appareil sous une surface fixe (sous un bureau ou une étagère), utilisez les supports longs pour assurer d'une ventilation adéquate et pour que l'appareil ne surchauffe pas.
PRECAUCIÓN	Cuando instale el dispositivo debajo de una superficie fija, debajo de un escritorio o debajo de un estante, utilice las abrazaderas largas para proporcionar una ventilación adecuada y no superar la temperatura operativa.

Electrical cautions



CAUTION

Before plugging a cable into any port, be sure to discharge the voltage stored on the cable by touching the electrical contacts to ground surface.

VORSICHT	Bevor Sie ein Kabel in einen Anschluss einstecken, entladen Sie jegliche im Kabel vorhandene elektrische Spannung, indem Sie mit den elektrischen Kontakten eine geerdete Oberfläche berühren.
MISE EN GARDE	Avant de brancher un câble à un port, assurez-vous de décharger la tension du câble en reliant les contacts électriques à la terre.
PRECAUCIÓN	Antes de conectar un cable en cualquier puerto, asegúrese de descargar la tensión acumulada en el cable tocando la superficie de conexión a tierra con los contactos eléctricos.



CAUTION

Static electricity can damage the chassis and other electronic devices. To avoid damage, keep static-sensitive devices in their static-protective packages until you are ready to install them.

VORSICHT	Statische Elektrizität kann das System und andere elektronische Geräte beschädigen. Um Schäden zu vermeiden, entnehmen Sie elektrostatisch empfindliche Geräte erst aus deren antistatischer Schutzhülle, wenn Sie bereit für den Einbau sind.
MISE EN GARDE	L'électricité statique peut endommager le châssis et les autres appareils électroniques. Pour éviter tout dommage, conservez les appareils sensibles à l'électricité statique dans leur emballage protecteur tant qu'ils n'ont pas été installés.
PRECAUCIÓN	La electricidad estática puede dañar el chasis y otros dispositivos electrónicos. A fin de impedir que se produzcan daños, conserve los dispositivos susceptibles de dañarse con la electricidad estática dentro de los paquetes protectores hasta que esté listo para instalarlos.

Cautions and Danger Notices

Danger Notices



CAUTION

Do not use the port cover tabs to lift the module. They are not designed to support the weight of the module, which can fall and be damaged.

VORSICHT	Verwenden Sie nicht die Laschen der Anschlussabdeckungen um ein Modul anzuheben. Diese sind nicht auf das Gewicht des Moduls ausgelegt, welches herunterfallen und dabei beschädigt werden kann.
MISE EN GARDE	N'utilisez pas les languettes du boîtier du port pour soulever le module. Elles ne sont pas conçues pour supporter le poids du module, qui peut tomber et être endommagé.
PRECAUCIÓN	No utilice las pestañas de la tapa del puerto para levantar el módulo. No están diseñadas para soportar el peso del módulo, por lo que este podría caerse y resultar dañado.



CAUTION

Use the screws specified in the procedure. Using longer screws can damage the device.

VORSICHT	Verwenden Sie die in der Anleitung aufgeführten Schrauben. Mit längeren Schrauben wird das Gerät möglicherweise beschädigt.
MISE EN GARDE	Utilisez les vis mentionnées dans les instructions. L'utilisation de vis plus longues peut endommager l'appareil.
PRECAUCIÓN	Utilice los tornillos especificados en el procedimiento. Si utiliza tornillos de mayor longitud, podría dañar el dispositivo.



CAUTION

Ensure that adequate ventilation is provided for the system. A 3 cm clearance is recommended above the device and 8 cm clearance is recommended on each side.

VORSICHT	Stellen Sie sicher, dass das System ausreichend belüftet wird. Über dem Gerät wird 3 cm Freiraum, auf beiden Seiten jeweils 8 cm Freiraum empfohlen.
MISE EN GARDE	Assurez-vous que le circuit est correctement ventilé. Il est recommandé de conserver un espace de 3 cm au-dessus du dispositif, et de 8 cm sur chaque côté.
PRECAUCIÓN	Asegúrese de proporcionar una ventilación adecuada al sistema. Se recomienda dejar 3 cm de espacio libre por encima del dispositivo y 8 cm a cada lado.



CAUTION

Ensure that adequate ventilation and airflow is provided for the system. A 4.5 cm (1.77 in) clearance is recommended above and below the device and 8 cm (3.15 in) clearance is recommended on each side.

VORSICHT	Achten Sie auf eine angemessene Belüftung und Luftzufuhr für das System. Ein Abstand von 4,5 cm über und unter dem Gerät und von 8 cm auf jeder Seite wird empfohlen.
MISE EN GARDE	Assurez-vous que le système est correctement ventilé. Un dégagement de 4,5 cm (1,77 po) est recommandé au-dessus et en dessous de l'appareil et un dégagement de 8 cm (3,15 po) est recommandé de chaque côté.
PRECAUCIÓN	Asegure una ventilación y un flujo de aire adecuados para el sistema. Se recomienda una holgura de 4.5 cm (1.77 in) por encima y por debajo del dispositivo, y 8 cm (3.15 in) en cada lado.

Danger Notices

A Danger statement indicates conditions or situations that can be potentially lethal or extremely hazardous to you. Safety labels are also attached directly to products to warn of these conditions or situations.

Ein Gefahrenhinweis warnt vor Bedingungen oder Situationen die tödlich sein können oder Sie extrem gefährden können. Sicherheitsetiketten sind direkt auf den jeweiligen Produkten angebracht um vor diesen Bedingungen und Situationen zu warnen.

Un énoncé de danger indique des conditions ou des situations potentiellement mortelles ou extrêmement dangereuses. Des étiquettes de sécurité sont posées directement sur le produit et vous avertissent de ces conditions ou situations.

Una advertencia de peligro indica condiciones o situaciones que pueden resultar potencialmente letales o extremadamente peligrosas. También habrá etiquetas de seguridad pegadas directamente sobre los productos para advertir de estas condiciones o situaciones.

General dangers



DANGER

The procedures in this manual are for qualified service personnel.

GEFAHR	Die Vorgehensweisen in diesem Handbuch sind für qualifiziertes Servicepersonal bestimmt.
DANGER	Les procédures décrites dans ce manuel doivent être effectuées par un personnel de maintenance qualifié.
PELIGRO	Los procedimientos de este manual deben llevarlos a cabo técnicos cualificados.



DANGER

Be careful not to accidentally insert your fingers into the fan tray while removing it from the chassis. The fan may still be spinning at a high speed.

GEFAHR	Die Finger dürfen nicht versehentlich in das Ventilatorblech gesteckt werden, wenn dieses vom Gehäuse abgenommen wird. Der Ventilator kann sich unter Umständen noch mit hoher Geschwindigkeit drehen.
DANGER	Faites attention de ne pas insérer vos doigts accidentellement dans le boîtier du ventilateur lorsque vous le retirez du châssis. Il est possible que le ventilateur tourne encore à grande vitesse.
PELIGRO	Procure no insertar los dedos accidentalmente en la bandeja del ventilador cuando esté desmontando el chasis. El ventilador podría estar girando a gran velocidad.



DANGER

This equipment is suitable for mounting on concrete or other noncombustible surfaces only.

GEFAHR	Dieses Gerät darf nur auf Beton oder auf andere, nicht brennbare Flächen installiert werden.
DANGER	Cet équipement est adapté à être monté sur du béton ou seulement sur d'autres surfaces non combustibles.
PELIGRO	Este equipo es apto para el montaje solamente en superficies de concreto ó en otro tipos de superficies no combustibles.

Electrical dangers



DANGER

For safety reasons, the ESD wrist strap should contain a series 1 megaohm resistor.

GEFAHR	Aus Sicherheitsgründen sollte ein EGB-Armband zum Schutz von elektronischen gefährdeten Bauelementen mit einem 1 Megaohm-Reihenwiderstand ausgestattet sein.
DANGER	Pour des raisons de sécurité, la dragonne ESD doit contenir une résistance de série 1 méga ohm.
PELIGRO	Por razones de seguridad, la correa de muñeca ESD deberá contener un resistor en serie de 1 mega ohmio.



DANGER

Make sure that the power source circuits are properly grounded.

GEFAHR	Achten Sie darauf, dass die Stromquellen-Schaltkreise ordnungsgemäß geerdet sind.
DANGER	Assurez-vous que les circuits de la source d'alimentation soient équipés de mise à la terre.
PELIGRO	Asegúrese que los circuitos de la fuente de energía cuenten con una conexión a tierra apropiada.

Cautions and Danger Notices
Danger Notices



DANGER

This device might have more than one power cord. To reduce the risk of electric shock, disconnect all power cords before servicing.

GEFAHR	Dieses System ist möglicherweise mit mehr als einem Netzkabel ausgestattet. Trennen Sie stets die Verbindung aller Netzkabel, bevor Sie Wartungsarbeiten durchführen, um die Gefahr eines Stromschlags auszuschließen.
DANGER	Ce commutateur peut comporter plusieurs cordons d'alimentation. Pour réduire les risques de choc électrique, déconnectez tous les cordons d'alimentation avant d'effectuer l'entretien de l'appareil.
PELIGRO	Este conmutador podría tener más de un cable de alimentación. Para reducir el riesgo de sufrir una descarga eléctrica, desconecte todos los cables de alimentación antes de proceder con la reparación.



DANGER

Make sure you use a power cord displaying the mark of the safety agency that defines the regulations for power cords in your country. The mark is your assurance that the power cord can be used safely with the device.

GEFAHR	Achten Sie darauf, dass Sie ein Netzkabel verwenden, das entsprechend Ihrer nationalen Sicherheitsvorschriften gekennzeichnet ist. Durch die Kennzeichnung ist sichergestellt, dass das Netzkabel gefahrlos für das Gerät verwendet werden kann.
DANGER	Assurez-vous d'utiliser un cordon d'alimentation portant la marque de l'organisme responsable des normes de sécurité locales. Cette marque vous assure que vous pouvez utiliser le cordon d'alimentation avec le dispositif en toute sécurité.
PELIGRO	Asegúrese de utilizar un cable de alimentación que muestre la marca de la agencia de seguridad que define las normas para los cables de alimentación en su país. La marca es su garantía de que el cable de alimentación puede utilizarse de forma segura con el dispositivo.



DANGER

To reduce the risk of electric shock, disconnect all power cords before servicing.

GEFAHR	Trennen Sie stets die Verbindung aller Netzkabel, bevor Sie Wartungsarbeiten durchführen, um die Gefahr eines Stromschlags auszuschließen.
DANGER	Afin de réduire les risques de choc électrique, débranchez tous les cordons d'alimentation avant d'effectuer l'entretien de l'appareil.
PELIGRO	Para reducir el riesgo de descarga eléctrica, desconecte todos los cables de alimentación antes de darle servicio.



DANGER

Disconnect the power cord from all power sources to completely remove power from the device.

GEFAHR	Ziehen Sie das Stromkabel aus allen Stromquellen, um sicherzustellen, dass dem Gerät kein Strom zugeführt wird.
DANGER	Débranchez le cordon d'alimentation de toutes les sources d'alimentation pour couper complètement l'alimentation du dispositif.
PELIGRO	Para desconectar completamente la corriente del instrumento, desconecte el cordón de corriente de todas las fuentes de corriente.



DANGER

To avoid high voltage shock, do not open the device while the power is on.

GEFAHR	Das eingeschaltete Gerät darf nicht geöffnet werden, da andernfalls das Risiko eines Stromschlags mit Hochspannung besteht.
DANGER	Afin d'éviter tout choc électrique, n'ouvrez pas l'appareil lorsqu'il est sous tension.
PELIGRO	Para evitar una descarga de alto voltaje, no abra el dispositivo mientras esté encendido.



DANGER

If the installation requires a different power cord than the one supplied with the device, make sure you use a power cord displaying the mark of the safety agency that defines the regulations for power cords in your country. The mark is your assurance that the power cord can be used safely with the device.

GEFAHR	Falls für die Installation ein anderes Stromkabel erforderlich ist (wenn das mit dem Gerät gelieferte Kabel nicht passt), müssen Sie sicherstellen, dass Sie ein Stromkabel mit dem Siegel einer Sicherheitsbehörde verwenden, die für die Zertifizierung von Stromkabeln in Ihrem Land zuständig ist. Das Siegel ist Ihre Garantie, dass das Stromkabel sicher mit Ihrem Gerät verwendet werden kann.
DANGER	Si l'installation nécessite un cordon d'alimentation autre que celui fourni avec le dispositif, assurez-vous d'utiliser un cordon d'alimentation portant la marque de l'organisation responsable de la sécurité qui définit les normes et réglementations pour les cordons d'alimentation dans votre pays. Cette marque vous assure que vous pouvez utiliser le cordon d'alimentation avec le dispositif en toute sécurité.
PELIGRO	Si la instalación requiere un cordón de corriente distinto al que se ha suministrado con el instrumento, verifique que usa un cordón de corriente que venga con la marca de la agencia de seguridad que defina las regulaciones para cordones de corriente en su país. Esta marca será su garantía de que el cordón de corriente puede ser utilizado con seguridad con el instrumento.

Dangers related to equipment weight



DANGER

Make sure the rack housing the device is adequately secured to prevent it from becoming unstable or falling over.

GEFAHR	Stellen Sie sicher, dass das Gestell für die Unterbringung des Geräts auf angemessene Weise gesichert ist, so dass das Gestell oder der Schrank nicht wackeln oder umfallen kann.
DANGER	Vérifiez que le bâti abritant le dispositif est bien fixé afin qu'il ne devienne pas instable ou qu'il ne risque pas de tomber.
PELIGRO	Verifique que el bastidor que alberga el instrumento está asegurado correctamente para evitar que pueda hacerse inestable o que caiga.



DANGER

Use safe lifting practices when moving the product.

GEFAHR	Beim Bewegen des Produktes ist auf eine sichere Hubtechnik zu achten.
DANGER	Utiliser des techniques de levage sûres pour déplacer le produit.
PELIGRO	Tenga mucho cuidado al levantar el producto para moverlo



DANGER

Mount the devices you install in a rack as low as possible. Place the heaviest device at the bottom and progressively place lighter devices above.

GEFAHR	Montieren Sie die Geräte im Gestell so tief wie möglich. Platzieren Sie das schwerste Gerät ganz unten, während leichtere Geräte je nach Gewicht (je schwerer desto tiefer) darüber untergebracht werden.
DANGER	Montez les dispositifs que vous installez dans un bâti aussi bas que possible. Placez le dispositif le plus lourd en bas et le plus léger en haut, en plaçant tous les dispositifs progressivement de bas en haut du plus lourd au plus léger.
PELIGRO	Monte los instrumentos que instale en un bastidor lo más bajos posible. Ponga el instrumento más pesado en la parte inferior y los instrumentos progresivamente más livianos más arriba.

Cautions and Danger Notices

Danger Notices



DANGER

When mounting the device under a fixed surface, under a desk, or under a shelf, mount the device with the bottom panel down and in a place where there is not much foot traffic. The fixed surface must be strong enough to withstand the weight of the device such that the device or the surface does not fall down.

GEFAHR	Wenn Sie das Gerät unter einer festen Oberfläche, einem Tisch oder einem Regal montieren, tun Sie dies mit der Unterseite nach unten und an einem Ort, an dem nicht viele Personen vorbeilaufen. Die feste Oberfläche muss stabil genug sein, um dem Gewicht des Geräts standzuhalten.
DANGER	Lors du montage de l'appareil sous une surface fixe (sous un bureau ou une étagère), installez l'appareil avec le panneau arrière pointé vers le bas et dans un endroit où il n'y a beaucoup de circulation piétonnière. La surface fixe doit être suffisamment solide pour supporter le poids de l'appareil de telle sorte que ni l'appareil ni la surface ne puissent tomber.
PELIGRO	Cuando instale el dispositivo debajo de una superficie fija, debajo de un escritorio, o debajo de un estante, hágalo con el panel inferior hacia abajo, en un lugar donde no se transite mucho. La superficie fija debe ser lo suficientemente fuerte como para soportar el peso del dispositivo, de modo que el dispositivo o la superficie no se desprendan.

Laser dangers



DANGER

All fiber-optic interfaces use Class 1 lasers.

GEFAHR	Alle Glasfaser-Schnittstellen verwenden Laser der Klasse 1.
DANGER	Toutes les interfaces en fibre optique utilisent des lasers de classe 1.
PELIGRO	Todas las interfaces de fibra óptica utilizan láser de clase 1.



DANGER

Use only optical transceivers that are qualified by Brocade Communications Systems, Inc. and comply with the FDA Class 1 radiation performance requirements defined in 21 CFR Subchapter I, and with IEC 60825 and EN60825. Optical products that do not comply with these standards might emit light that is hazardous to the eyes.

GEFAHR	Verwenden Sie nur optische Transceiver, die von Brocade Communications Systems zugelassen sind und die die Anforderungen gemäß FDA Class 1 Radiation Performance Standards in 21 CFR, Unterkapitel I, sowie IEC 60825 und EN60825 erfüllen. Optische Produkte, die diese Normen nicht erfüllen, können Strahlen aussenden, die für das menschliche Auge gefährlich sind.
DANGER	Utilisez uniquement des émetteurs-récepteurs optiques certifiés par Brocade Communications Systems, Inc. et conformes aux exigences sur la puissance de rayonnement de catégorie 1 de la FDA définies au sous-chapitre 21 CFR I et à les normes IEC 60825 et EN60825. Les produits optiques non-conformes à ces normes sont susceptibles d'émettre une lumière dangereuse pour les yeux.
PELIGRO	Utilice sólo transceptores ópticos aprobados por Brocade Communications Systems, Inc. y que cumplan con las normas IEC 60825 y EN60825, y con los estándares de rendimiento Clase 1 de FDA definidos en el subcapítulo I de 21 CFR. Los productos ópticos que no cumplan con estos estándares pueden emitir luz dañina para los ojos.



© 2018 ARRIS Enterprises, LLC. All rights reserved.
350 West Java Dr. Sunnyvale, CA 94089. USA
www.ruckuswireless.com