



PX501 Gen III

User's Manual



©2018 RuggON Corporation. All rights reserved.

TRADEMARKS

RuggON logo is a trademark of RuggON Corporation, registered in the United States Patent and Trademark Office and in other countries. Microsoft and the Windows logo are either registered trademarks or trademarks of Microsoft Corporation in the United States and/or other countries. Microsoft products are licensed to OEMs by Microsoft Licensing, Inc., a wholly owned subsidiary of Microsoft Corporation. The Bluetooth® word mark and logos are registered trademarks owned by Bluetooth SIG, Inc. All other brand and product names are trademarks or registered trademarks of their respective owners.

Images shown in this document may vary slightly from actual products at time of shipping. Information in this manual is subject to change without notice.

Table of Contents

About This Manual

Related Information	1
Conventions	1

Basic Safety Guidelines

Intended Use	2
Maintenance and Operation Overview	2
Safety	3
Electrical Hazards	3
Environmental	3
Radio Transmissions	4
Cleaning and Servicing	4
Regulatory and Certification	4
Lithium Battery Safety Statement	5

Chapter 1. Introduction

About This Guide	6
Unpacking the Device	6
Technical Specifications	6
PX501 Configuration Options	8
Parts List	9
Identifying the Device	10
Identifying the Digitizer	14
Dimensions	15
Touch Screen Features	16

Chapter 2. Getting Started

First Time Use	17
Charging the Battery	17
Powering the Device On and Off	18
Installing the Micro SIM Card	19
Removing the Micro SIM Card	20
Installing the MicroSD Card	21
Removing the MicroSD Card	22

Using the Digitizer	23
Removing the Protective Film from the Display	24

Chapter 3. Operation

Opening the I/O Compartment Cover	25
Closing the I/O Compartment Cover.....	26
Connecting to External Cabling	27
Handstrap, Carrying Handle and Shoulder Strap.....	29
Installing the Standard Battery	33
Removing the Standard Battery	34
Connecting to a Wireless Network.....	35

Chapter 4. Using BIOS Setup Utility

When to Use the BIOS Setup Utility	37
Accessing the BIOS Setup Utility.....	37
Installation an Operating System.....	38
BIOS Passwords	41
EC and BIOS	43

Chapter 5. Using the DashON Utility

Overview	48
----------------	----

Chapter 6. Troubleshooting

Troubleshoot the Wi-Fi Connection	50
Troubleshoot Operating the Computer	51
Call Product Support	51

Chapter 7. Maintenance

Cleaning the Device	52
Returning the Device.....	52
Contacting RuggON	52

About This Manual

The PX501 User's Manual provides instruction for qualified personnel to follow when setting up a new PX501 device.

This document is intended for use by qualified personnel to compliment the training and expertise, not to replace it.

Related Information

Current information and manuals are available for download at the following website:

<http://www.ruggon.com>

Conventions

Bolded or underlined text is used to emphasize the designated information.



A Note is used to provide additional information for the device or settings.



A Caution is used to warn against potential hazards or to caution against unsafe practices.



A Warning is used to identify immediate hazards for property damage, injury or death.

Basic Safety Guidelines

The following safety guidelines are intended to help protect the user from injury and prevent damage to the hardware.

- Do not place anything on the AC adapters power cable and make sure the cable is not located where it can be tripped over or stepped on.
- Do not cover the AC adaptor as it reduces the cooling.
- Do not use the AC adapter while it is inside the carrying case.
- Use only the AC adapter, power cord, and batteries that are approved for use with the device. Use of another type of battery or AC adapter may cause risk of fire or explosion.
- If you use an extension cable with the AC adapter, ensure that the total ampere rating of all products plugged in to the extension cable does not exceed the ampere rating of the extension cable.
- If the device is moved between environments with very different temperature and/ or humidity ranges, condensation may form on or within the device. Avoid damaging the device by allowing sufficient time for the moisture to evaporate before using the device.
- When disconnecting cables, pull on the connector or on its strain relief loop, not on the cable itself. When pulling out or plugging in the connector, keep it evenly aligned to prevent bending the connector pins.

Intended Use

The PX501 rugged tablet is equipped with multi-functional terminals for stationary and mobile applications in industrial environments such as logistics, warehousing, fleet management, manufacturing and the automotive industry.

Read the safety guidelines thoroughly before starting any servicing on the device. Read the guidelines before powering up the device, and keep this document for later use.

The operator is solely responsible for any damage resulting from unauthorized modifications to the device.

Unintended Application Use

The device is not designed for use in life-support systems or critical safety/security systems where system malfunction can lead to the direct or indirect endangerment of human life. The operator is fully responsible for using the device in these situations.

Maintenance and Operation Overview

The PX501 is designed and manufactured according to strict controls and following the stated safety regulations. The following list identifies incorrect operating uses of the PX501. Incorrect use of the PX501 can lead to hardware damage, safety issues and possible risk to personnel health:

- The PX501 is under operation by untrained personnel;
- The PX501 is not maintained as recommended;
- The PX501 is not used as intended.

Safety

To prevent injury and damage, read the following safety guidelines prior to operating the device. The manufacturer assumes no liability for any and all damages arising from misuse or noncompliance with these guidelines.

Electrical Hazards

Cleaning/Service: Power Off the PX501

- Disconnect the PX501 from power before cleaning or servicing it.

Power Adapter

Contact an authorized service personnel for repairs to the power pack. In the event of a blown fuse after replacing the fuse, contact an authorized service personnel to avoid electrical shock.

Use only Supplied Power Cables

RuggON power cables meet industrial requirements for low-temperature flexibility, UV resistance, and oil resistance. Use only supplied power cables from RuggON.

If other power cables are used, the following may apply:

- The operator is solely responsible for the resulting damage;
- All RuggON warranties are void.

Environmental Hazards

Do not use the PX501 in locations near/with flammable gases or vapor. The use of electrical equipment in explosive environments can be dangerous.

- Turn off the device when near a gas station, fuel depot, chemical plant or a place where blasting operations take place.

Environmental

Ambient Temperature

The PX501 operates on the basis of a passive cooling concept which internal waste heat is released via the housing surface and requires fresh airflow in the environment.

- Operating the PX501 with no fresh cooling air may cause overheating and damage to the device.
- The operating environment should not be enclosed to prevent the cool air being heated by the heat waste from the device.

Connecting and Disconnecting External Devices

To prevent the considerable damage, the PX501 and the external device should be disconnected from power when connecting/disconnecting excluding USB devices.

Only Use Authorized Accessories

Only use the supplied cables, power packs and other accessories that have been tested and approved by RuggON. Contact your local distributor for further information.

Radio Transmissions

Permitted Transmission Power

Follow the national regulations for the maximum permitted transmission power.

The operator is solely responsible for this type of operation.

Radio Frequency Limited Locations

Considering the radio frequency limitation in hospitals and aircraft, the PX501 can only be installed with permission.

Industrial computers may affect the function of implanted medical devices such as pacemakers and may cause malfunction.

Cleaning and Servicing

- Disconnect the PX501 from power before cleaning or servicing.
- Never clean the PX501 with compressed air, a pressure washer or a vacuum cleaner.
- If necessary, clean the housing of the PX501 with a damp cloth.
- Clean the touch-screen with a nonabrasive cloth.

Regulatory and Certification

FCC

This equipment has been tested and found to comply with the limits for a Class B digital device, pursuant to part 15 of the FCC Rules. These limits are designed to provide reasonable protection against harmful interference when the equipment is operated in a commercial environment.

This equipment generates, uses, and can radiate radio frequency energy and, if not installed and used in accordance with the instruction manual, may cause harmful interference to radio communications. Operation of this equipment in a residential area is likely to cause harmful interference in which case the user will be required to correct the interference at his own expense.

However, there is no guarantee that interference will not occur in a particular installation. If this equipment does cause harmful interference to radio or television reception, which can be determined by turning the equipment off and on, the user is encouraged to try to correct the interference by one or more of the following measures:

- Reorient or relocate the receiving antenna.
- Increase the separation between the equipment and receiver.
- Connect the equipment into an outlet on a circuit different from that to which the receiver is connected.
- Consult the dealer or an experienced radio / TV technician for help.



Any changes or modifications not expressly approved by the grantee of this device could void the user's authority to operate the equipment.

This device is operation in 5.15 – 5.25GHz frequency range, then restricted in indoor use only, Outdoor operations in the 5.15 – 5.25GHz is prohibit.

This device is slave equipment; the device is not radar detection and not ad-hoc operation in the DFS band.

Labeling Requirements

This device complies with Part 15 of the FCC Rules. Operation is subject to the following two conditions: (1) this device may not cause harmful interference, and (2) this device must accept any interference received, including interference that may cause undesired operation.

RF Exposure Information (SAR)

This device meets the government's requirements for exposure to radio waves. This device is designed and manufactured not to exceed the emission limits for exposure to radio frequency (RF) energy set by the Federal Communications Commission of the U.S. Government.

The exposure standard employs a unit of measurement known as the Specific Absorption Rate, or SAR. The SAR limit set by the FCC is 1.6 W/kg. Tests for SAR are conducted using standard operating positions accepted by the FCC with the EUT transmitting at the specified power level in different channels.

The highest SAR value for the device as reported to the FCC WLAN 0.657W/kg; WWAN 1.098 W/kg when placed next to the body.

Canada

This digital apparatus does not exceed the Class B limits for radio noise emissions from digital apparatus as set out in the radio interference regulations of the Canadian Department of Communications.

Le présent appareil numérique n'émet pas de bruits radioélectriques dépassant les limites applicables aux appareils numériques de Classe B prescrites dans le règlement sur le brouillage radioélectrique édicté par le Ministère des Communications du Canada.

Changes and modifications not expressly approved by the manufacturer or registrant of this equipment can void your authority to operate this equipment under Industry Canada rules.

Les changements et modifications non expressément approuvés par le fabricant ou le détenteur de cet équipement peuvent annuler votre droit à utiliser cet appareil en vertu des règles d'Industrie Canada.

Antenna Statement

Under Industry Canada regulations, this radio transmitter may only operate using an antenna of a type and maximum (or lesser) gain approved for the transmitter by Industry Canada. To reduce potential radio interference to other users, the antenna type and its gain should be so chosen that the equivalent isotropically radiated power (e.i.r.p.) is not more than that necessary for successful communication.

Conformément à la réglementation d'Industrie Canada, le présent émetteur radio peut fonctionner avec une antenne d'un type et d'un gain maximal (ou inférieur) approuvé pour l'émetteur par Industrie Canada. Dans le but de réduire les risques de brouillage radioélectrique à l'intention des autres utilisateurs, il faut choisir le type d'antenne et son gain de sorte que la puissance isotrope rayonnée équivalente (p.i.r.e.) ne dépasse pas l'intensité nécessaire à l'établissement d'une communication satisfaisante.

Licence exempt

This device complies with Industry Canada licence-exempt RSS standard(s). Operation is subject to the following two conditions:

1. this device may not cause interference
2. this device must accept any interference, including interference that may cause undesired operation of the device.

Le présent appareil est conforme aux CNR d'Industrie Canada applicables aux appareils radio exempts de licence. L'exploitation est autorisée aux deux conditions suivantes :

1. l'appareil ne doit pas produire de brouillage
2. l'utilisateur de l'appareil doit accepter tout brouillage radioélectrique subi, même si le brouillage est susceptible d'en compromettre le fonctionnement.

This Class B digital apparatus complies with Canadian ICES- 003.

Cet appareil numérique de la classe B est conforme à la norme NMB-003 du Canada.

IMPORTANT NOTE: IC Radiation Exposure Statement

This EUT is compliant with SAR for general population/uncontrolled exposure limits in IC RSS-102 and had been tested in accordance with the measurement methods and procedures specified in IEEE 1528. SAR is measured with the device at 0 mm to the extremity, while transmitting at the highest certified output power level in all frequency bands of the device.

The maximum SAR value is 0.627 (WLAN) / 1.098 (WWAN) W/kg

This equipment should be installed and operated with a minimum distance of 0 cm between the radiator and your extremity. This device and its antenna(s) must not be co-located or operating in conjunction with any other antenna or transmitter. The County Code Selection feature is disabled for products marketed in the US/Canada.

IC SAR warning

Radio Frequency (RF) Exposure Information

The radiated output power of the Wireless Device is below the Industry Canada (IC) radio frequency exposure limits. The Wireless Device should be used in such a manner such that the potential for human contact during normal operation is minimized.

This device has been evaluated for and shown compliant with the IC Specific Absorption Rate ("SAR") limits when installed in specific host products operated in portable exposure conditions.

Informations concernant l'exposition aux fréquences radio (RF)

La puissance de sortie émise par l'appareil de sans fil est inférieure à la limite d'exposition aux fréquences radio d'Industry Canada (IC). Utilisez l'appareil de sans fil de façon à minimiser les contacts humains lors du fonctionnement normal.

Ce périphérique a été évalué et démontré conforme aux limites SAR (Specific Absorption Rate – Taux d'absorption spécifique) d'IC lorsqu'il est installé dans des produits hôtes particuliers qui fonctionnent dans des conditions d'exposition à des appareils portables.

The device could automatically discontinue transmission in case of absence of information to transmit, or operational failure. Note that this is not intended to prohibit transmission of control or signaling information or the use of repetitive codes where required by the technology.

The device for the band 5150-5250 MHz is only for indoor usage to reduce potential for harmful interference to co-channel mobile satellite systems; the maximum antenna gain permitted (for devices in the bands 5250-5350 MHz and 5470-5725 MHz) to comply with the e.i.r.p. limit; and The maximum antenna gain permitted (for devices in the band 5725-5850 MHz) to comply with the e.i.r.p. limits specified for point-to-point and non-point-to-point operation as appropriate, as stated in section A9.2(3). In addition, High-power radars are allocated as primary users (meaning they have priority) of the band 5250-5350 MHz and this radar could cause interference and/or damage to LE-LAN devices.

CE Marking

This product has passed the CE test for environmental specifications when shielded cables are used for external wiring. We recommend the use of shielded cables. Please contact your local representative for ordering information.

This product has passed the CE test for environmental specifications. Test conditions for passing included the equipment being operated within an industrial enclosure. In order to protect the product from being damaged by ESD (Electrostatic Discharge) and EMI leakage, we strongly recommend the use of CE-compliant industrial enclosure products.

European declaration of conformity

According to ISO / IEC Guide 22 and EN 450 14 Manufacturer's Name: Ruggon Corporation.
Manufacturer's Address: 4F, No. 298, Yang Guang St., NeiHu. Taipei, Taiwan,

Declares, under our sole responsibility, that the product: Product Name: Nomad 5
Model Number: PX501

Conforms to the following Product Specifications:

- RED 2014/53/EU LVD 2014/35/EU EMC 2014/53/EU RED
- ETSI EN 300 328
- ETSI EN 300 893
- ETSI EN 303 413
- ETSI EN 301 489-1
- ETSI EN 301 489-3
- ETSI EN 301 489-17
- EN 55032: 2012+AC: 2013
- EN 55024: 2010+A1:2015
- EN 60950-1:2006/A11:2009/A1:2010/A12:2011/A2:2013

Supplementary information

In addition, the product is battery powered and the power supply provided with this product has been certified to IEC 60950: 2005 2nd edition +Am1:2009+Am2: 2013/ IEC 62368-1: 2014. As manufacturer, we declare under our sole responsibility that the equipment follows the provisions of the Standards stated above.

CB

This device complies with the IEC 60950-1(ed.2) /am1/am2

Lithium Battery Safety Statement



Lithium battery inside. Danger of explosion if battery is incorrectly replaced. Replace only with same or equivalent type recommended by battery manufacturer.

Chapter 1. Introduction

The PX501 is a rugged device equipped with 802.11, Bluetooth and GNSS for wireless data communications.

The PX501 is a rugged 10.1" tablet computer capable of 1920 x 1200 resolution. The PX501 supports the following operating systems:

- Windows® 10 IoT Enterprise CBB

About This Guide

The PX501 User Manual provides instruction for qualified personnel to use as a guide for setup of the device. This document is not intended to replace the training and expertise of the end-user.

Unpacking the Device

Before you begin the installation or configuration process make sure to inspect all components and accessories. Contact your representative if there are any missing or damaged items. See "Contacting RuggON" on page 52.

Technical Specifications

Table 1. Technical Specifications

Item	Description
Display	10.1-inch LED Backlight, 1920 (W) x 1200 (H) WUXGA
Touch screen	10-point capacitive touch screen with optional digitizer
Brightness	1000 nits (before touch)
CPU	Intel Core i5-7300U 2.6 GHz
Operating System (Optional)	<ul style="list-style-type: none"> ■ Windows® 10 IoT Enterprise CBB
RAM	DDR4@2400 MT/s 8 GB RAM
Storage	M.2 SSD 128 GB (optional: 256 GB)
Battery	<ul style="list-style-type: none"> ■ Standard hot swappable battery: 10.8V, 4500mAh, Li-polymer ■ Extended hot swappable battery: 10.8V, 9000mAh, Li-polymer (optional)
Power Supply	AC 100V ~ 240V, 50~60Hz input; 19VDC@3.42A, 65W
Dimensions (W x H x L)	280 mm (11") x 23 mm (0.9") x 195 mm (7.7")
Weight	1.36 kg (3 lbs)

Item	Description
Wireless	
WLAN	Wi-Fi IEEE 802.11 a/b/g/n/ac
Bluetooth	Bluetooth V4.2
WWAN (Optional)	Option 4G LTE
Sensor	
Sensor	Gyroscope, G Sensor, E-compass, Light Sensor
I/O	
Docking Connector	12-pin
DC-IN Jack	x1
Micro SIM Card Slot	x1
Audio Jack	x1; headphone / microphone combo
USB 3.01	x2; type A x1, type C x1
RS-232	x1
Micro HDMI	x1
Ethernet	x1
Security	
TPM	TPM 1.2
BIOS On/Off for I/Os	YES
Data Collection	
Camera	<ul style="list-style-type: none"> ■ Front: 2.0 Mega-Pixels camera ■ Rear: 8.0 Mega-Pixels camera with LED auxiliary light and Auto-focus
GNSS	YES
NFC	Optional
Barcode Reader	Optional
Smart Card Reader	Optional

Item	Description
Rugged Specifications	
Drop	153 cm (5 feet), 26 drops on plywood
MIL-STD 810G	<ul style="list-style-type: none"> ■ Vibration (MIL-STD-810G Method 514.6 Category 4, Fig 514.6C-1, Fig 514.6C-2, Fig 514.6C-3) ■ Drop (MIL-STD-810G Method 516.6 Procedure IV) ■ Mechanical shock (MIL-STD-810G Method 516.6 Procedure I, Procedure V) ■ Operation and storage temperature (MIL-STD-810G Method 501.5 and 502.5) ■ Humidity MIL-STD-810G Method 507.5 Humidity Procedure II Aggravated Cycles (Fig 507.5-7)
IP rating	IP65
Operating Temperature Range	-20°C (-4°F) to 60°C (140°F)
Storage Temperature Range	-30°C (-22°F) to 70°C (158°F)
Humidity	5-95% without condensation

PX501 Configuration Options

The following options are available for the PX501:

- NFC module
- Barcode reader
- Smart card reader
- High capacity battery
- 4G LTE
- Digitizer

Parts List

The PX501 is shipped with the following items. All other accessories are sold and ordered separately. For help, contact your local RuggON sales representative. See “*Contacting RuggON*” on page 52.



PX501

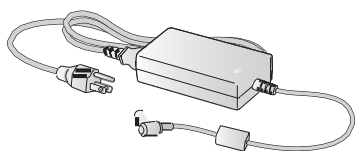

Power Adapter

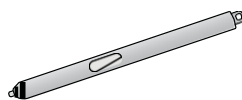

Stylus or Digitizer

Identifying the Device

Overview

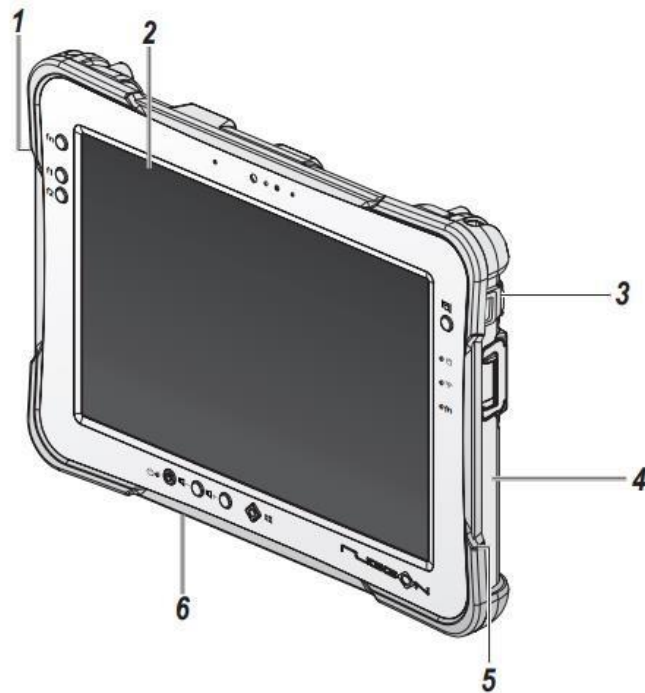

Figure 1. Overview

Table 2. Overview

No	Item	Description
1	Left view	See “Side View” on page 13 for further information.
2	Front view	See “Front View” on page 11 for further information.
3	Rear view	See “Rear View” on page 14 for further information.
4	Right view	See “Side View” on page 13 for further information.
5	Rubber bumpers	Easy to grip rubber bumpers enable the rugged tablet to withstand shocks and drop for use in demanding environments.
6	Bottom view	See “Bottom View” on page 12 for further information.

Front View

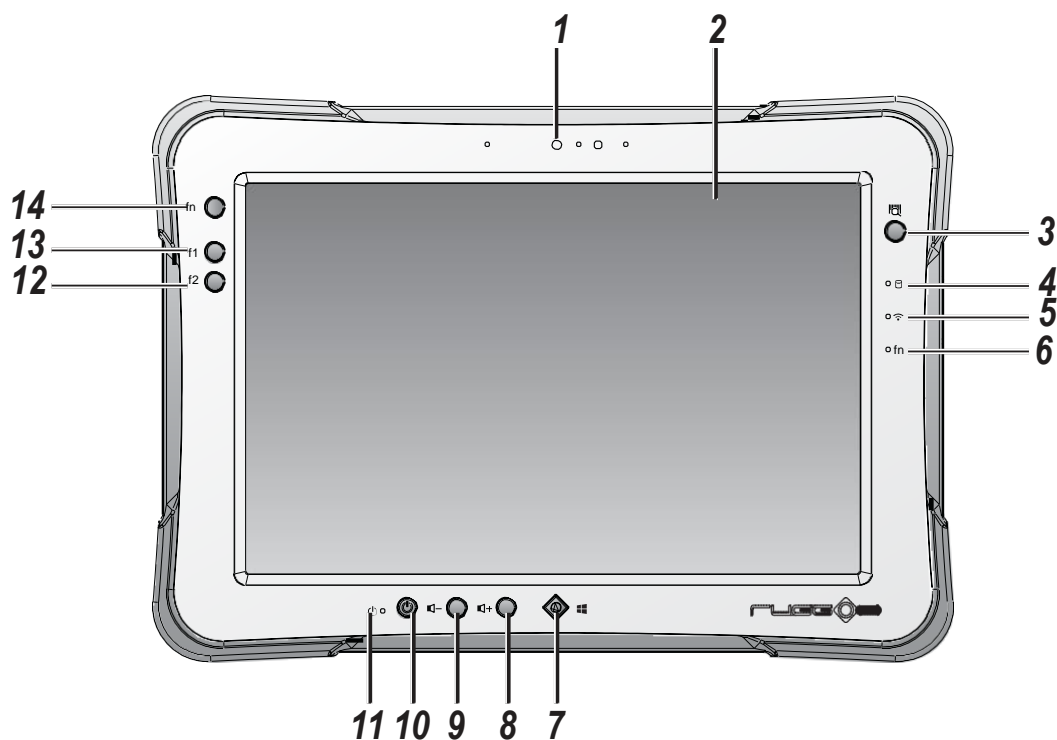

Figure 2. Front View

Table 3. Front View

No	Item	Description
1	Front camera	2.0 Mega-Pixels camera.
2	Touch screen	5-point capacitive touch.
3	Barcode trigger	If barcode scanner is installed, press to scan.
4	Battery LED	Display battery status, see “LED Status” on page 12.
5	Wi-Fi LED	The Wi-Fi LED lights to indicate Wi-Fi is enabled.
6	FN LED	The FN LED lights when the function switch on.
7	Home key	Windows® home key.
8	Volume +	Volume increase.
9	Volume -	Volume decrease.
10	Power key	Turns the PX501 on or off.
11	Power LED	The power LED lights when the device is on.
12	F2 key	Programmable function key.
13	F1 key	Programmable function key.
14	FN key	Programmable function key.

LED Status

Table 4. LED Status

Item	Status	Description
Power	Green: On	Power on
	Off	Power off
Battery	Green: On	Fully charged
	Amber: On	Charging
	Amber: Blinking	Low power < 15%
	Off	Not charging / no battery
FN	Blue: On	FN function switch on
	Blue: Off	FN function switch off
Wi-Fi	Blue: On	Wi-Fi on
	Blue: Off	Wi-Fi off

Bottom View

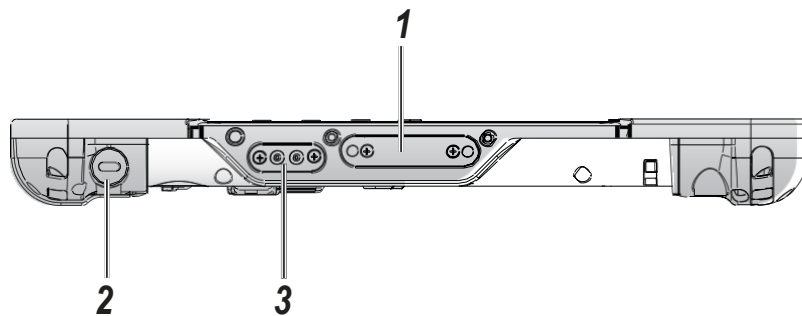

Figure 3. Bottom View

Table 5. Bottom View

No	Item	Description
1	Docking connector	12 pin connector for docking onto a station.
2	Kensington lock	Lock the PX501 to a stationary object for security.
3	Pass-through	Dual pass-through for WLAN, GNSS and WWAN.

Side View

Figure 4. Side Views

Table 6. Side View

No	Item	Description
1	Micro HDMI	Connect HDMI devices to the PX501.
2	USB 3.1 Type C	Connect USB devices to the PX501.
3	Left I/O compartment cover	Open to access the left I/O port.
4	Tether hole	Digitizer or stylus can be tethered to it.
5	USB 3.1	Connect USB devices to the PX501.
6	Audio jack	Connect a 3.5 mm jack for a headphone or external speakers.
7	Ethernet	Connect the PX501 to an Ethernet (RJ-45) cable.
8	DC-IN jack	Insert power connector to charge battery.
9	RS-232	Connect the PX501 to a serial device.
10	DC-IN cover	Open to access the DC-IN jack.
11	Right I/O compartment cover	Open to access the right I/O port.

Rear View

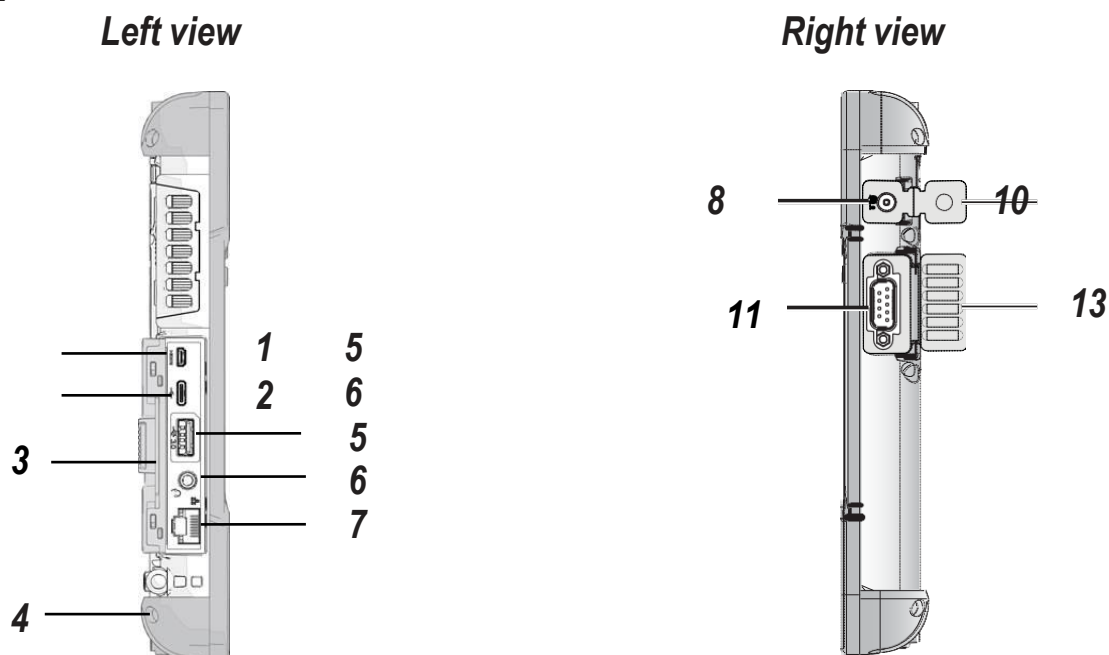
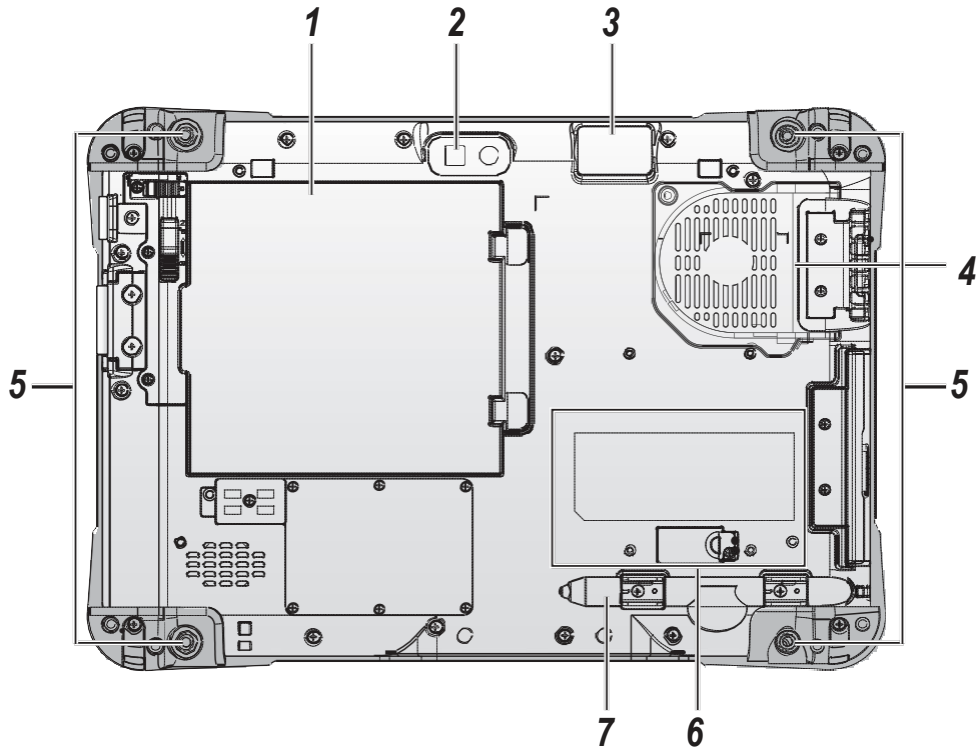

Figure 5. Rear View

Table 7. Rear View

No	Item	Description
1	Battery	To install a battery, an external battery is optional.
2	Rear camera	5.0 Mega-Pixels camera with LED auxiliary light.
3	Barcode reader	For installing a barcode reader. (Optional)
4	Fan	Embedded fan for cooling.
5	Securing holes	Secure the bumpers and the D-rings for the handstrap and shoulder strap.
6	Expansion bay	Remove the cover to find the expansion accessory connector.
7	Stylus holder	Place stylus here.

Identifying the Digitizer (Optional)

You can use the optional digitizer to control your PX501 as with a mouse or keyboard.

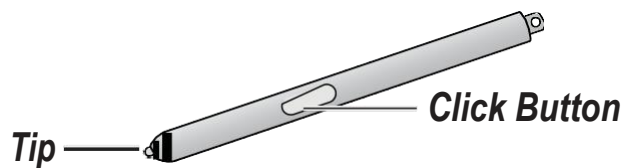

Figure 6. Digitizer View

Dimensions

The following image lists the device dimensions without add-ons (mm/inches).

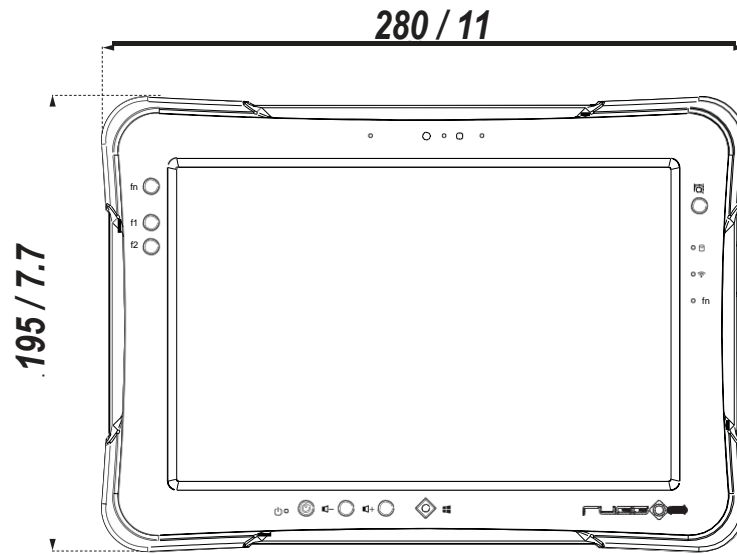

Figure 7. Front View Dimensions

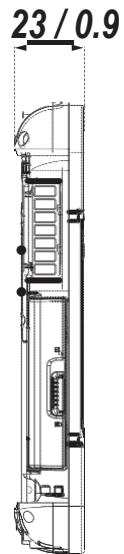

Figure 8. Side View Dimensions

Touch Screen Features



Always use the point of the digitizer for clicking or making strokes on the touch screen.
Never use an actual pen, pencil, or sharp/abrasive object on the touch screen.

The digitizer is used as if it were a pen or pencil. Touch the screen with the tip of the digitizer then remove the digitizer from the screen.

After each use, replace the digitizer in the digitizer holder for proper care and to preserve the life of the digitizer.

Using a digitizer is similar to moving the mouse pointer then left-clicking icons on a desktop computer screen.

The following actions are available through the use of the digitizer:

- Open applications
- Choose commands in menu
- Select options in dialog box or drop-down menu
- Drag the scroll bar
- Drag across the text to select content
- Place the cursor in a text box before typing

A right click is generated by tapping the mouse icon in the system tray. After tapping, the mouse icon highlights the right button of the icon in red. The next touch screen tap is treated as a right click. The mouse icon returns to the left button highlighted in red so subsequent taps are treated as left clicks.

A digitizer replacement kit is available.



To prevent damage or malfunction, always dry the touch screen when wet.

Chapter 2. Getting Started

This section provides an outline of the steps necessary to setup a new PX501. A detailed guide follows the listed items, see as follows.

For additional technical assistance, contact your RuggON representative. See “*Contacting RuggON*” on page 52.



It is recommended to installing or remove accessories on a clean, well-lit work surface. To protect yourself and the device from electrostatic discharge, wear anti-static wrist straps or place the device on an anti-static mat.

First Time Use

PX501 is under “Battery Ship Mode” and will not power on to preserve the battery and prevent power loss. To enable “Regular Mode” and activate the battery, please connect the power adapter to power on.

Charging the Battery

When you use the AC adapter to connect your PX501 to a power outlet, the standard and external (optional) battery will automatically begin to recharge.

While the battery is charging, the power LED will be active. When the battery is fully charged, the power LED is lit a solid green.

1. Flip open the DC-IN cover to expose the DC-IN jack.

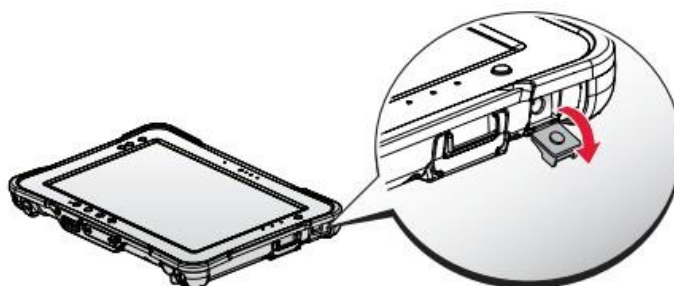

Figure 9. Opening the DC-IN Cover

2. Connect the AC adapter to the DC-IN port.

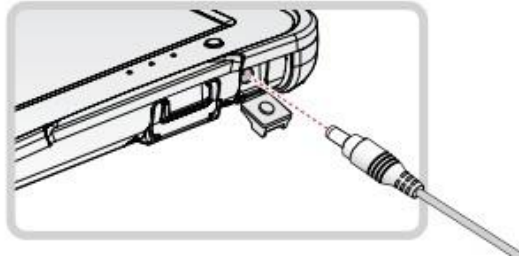

Figure 10. Connecting the AC Adapter

After charging the battery, disconnect the AC adapter and close the DC-IN cover.

1. Insert one end of the cover first and angle the cover to seat it in place.
2. Push in the cover to seal the DC-IN compartment.

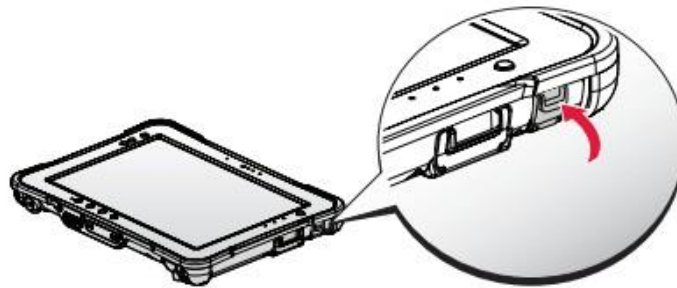

Figure 11. Closing the DC-IN Cover



The DC-IN cover must be inserted correctly to prevent internal damage to the device.

Powering the Device On and Off

Powering On the Device

Only power on the PX501 after connecting all of the peripherals and cabling.

1. Press and hold the power button until the screen lights. The device runs through the start up sequence and powers up.

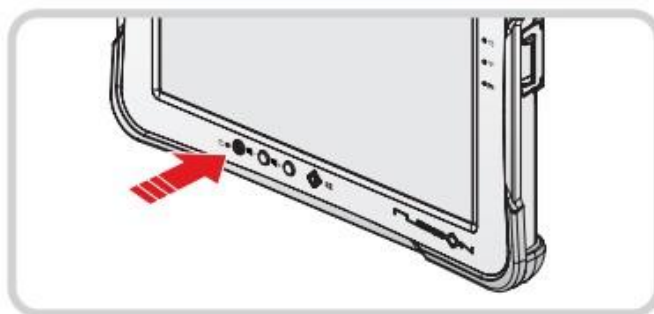



Figure 12. Power On the PX501

Powering Off the Device

- Start screen:
 1. Tap  > **Shut down**.
- Desktop screen:
 1. Tap and hold  at the bottom left corner of the Desktop screen.
 2. Tap **Shut down or sign out** > **Shut down**.
- Both Start screen and Desktop screen:
 1. Display charm bar and tap **Settings**.
 2. Tap **Power** > **Shut down**.

Installing the Micro SIM Card (Optional)

The device includes a micro SIM card slot for cellular and wireless connection. Only a micro SIM card is supported in the slot.



Check with your network or cellular service provider for availability and cost rates.

1. Power off the PX501. See “Powering Off the Device” on page 19.
2. Remove the service door and its screws.
3. Disconnect the antenna and remove the 4G LTE card (optional) from the slot.

Back View

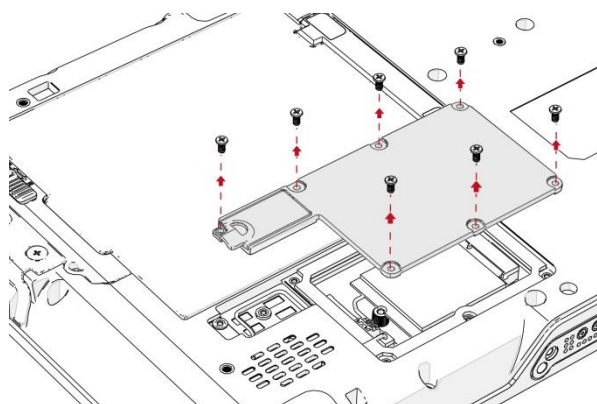

Figure 13. Back View: Remove Service Door

Back View

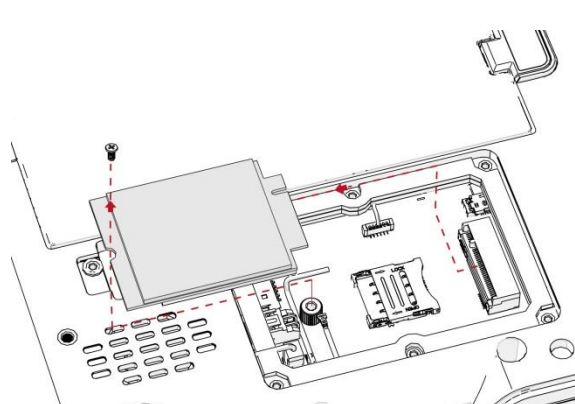

Figure 14. Back View: Remove 4G LTE card

4. Take the micro SIM card from its packaging.
5. Push the SIM card cover to open and place the micro SIM card to the slot.
6. Close the SIM card cover.

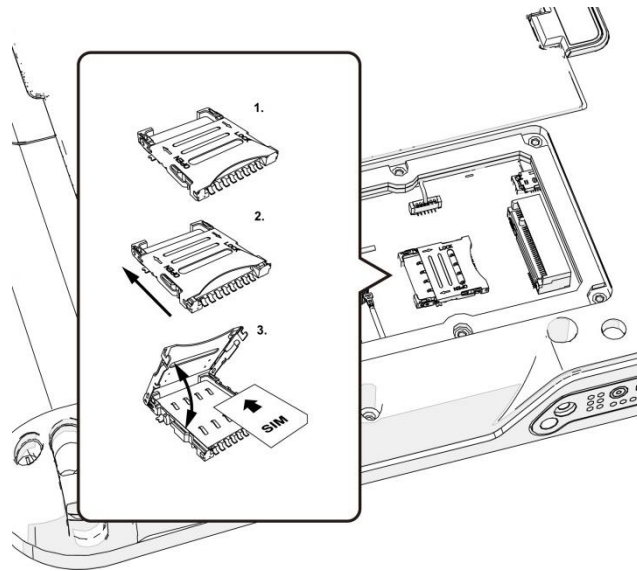

Figure 15. Installing the Micro SIM Card

7. Install the 4G LTE card and its antennas to the slot and close the service door.

Using the Digitizer

Following the information below when using a digitizer:

- Use only the included digitizer to touch the screen. Do not place any objects on its surface and do not press down strongly with sharp-pointed or hard objects that may leave marks (e.g., nails, pencils and ball point pens).
- Use the digitizer only for touching the screen. Using it for any other purpose may damage the digitizer and result in scratches on the screen.
- The digitizer uses electromagnetic induction and may not work properly near strong electrical field or magnetic field such as:
 - Near AM radio base stations or relay station antennas
 - Near CRT displays that generate strong electromagnetic field noise

Move the digitizer away from such locations so it works properly.

- The pointer cannot follow the digitizer movement if you move the digitizer too quickly.

To make a selection, tap the screen once with the digitizer. To double-click, tap twice without pausing. To do a right-click, tap the screen once and hold the tip of the digitizer on the screen, the right-click icon appears. Press the click button is the same as a right click.

Removing the Protective Film from the Display

The front display of the PX501 is protected during transport by a transparent film. This film should remain on the front display during assembly to avoid damage to the front display surface.

Only remove the film once all of the assembly work has been completed.

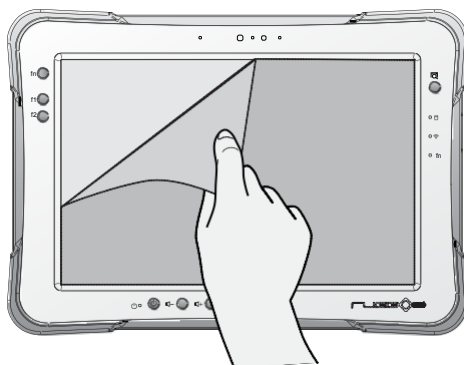

Figure 16. Removing the Protective Film

Chapter 3. Operation

Opening the I/O Compartment Cover

1. Place the device display side down on a clean work surface.
2. Locate the I/O compartment cover.

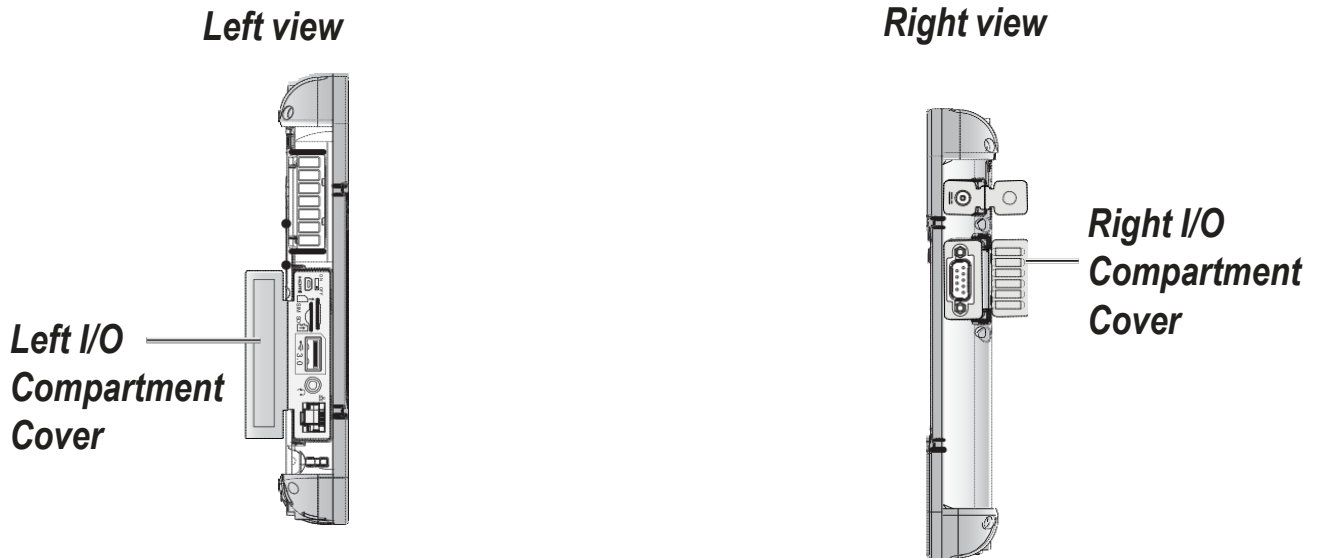

Figure 17. Side View: Locating the I/O Compartment Cover

3. Unlock the latch. (Only available for the left I/O compartment cover)

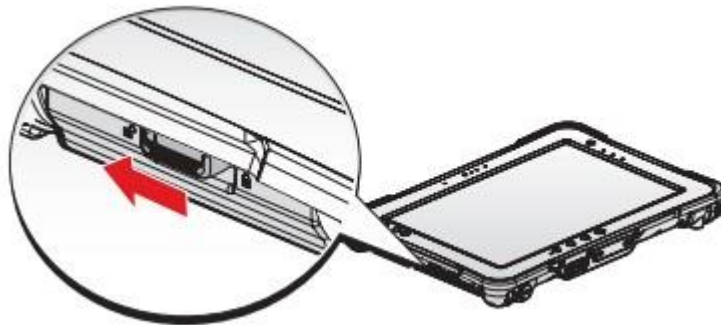

Figure 18. Unlocking the Latch

4. Pull out the I/O compartment cover.

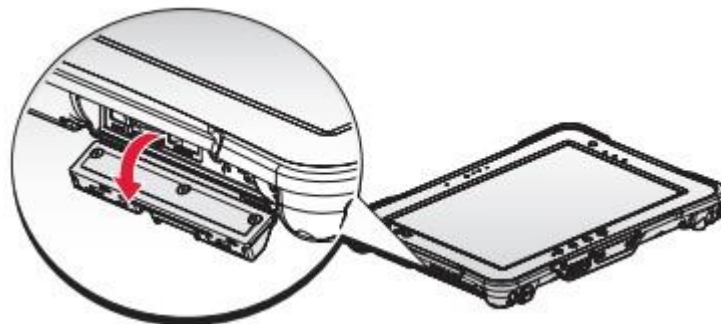

Figure 19. Opening the I/O Compartment Cover

Closing the I/O Compartment Cover

1. Place the device display side down on a clean work surface.
2. Locate the I/O compartment cover.

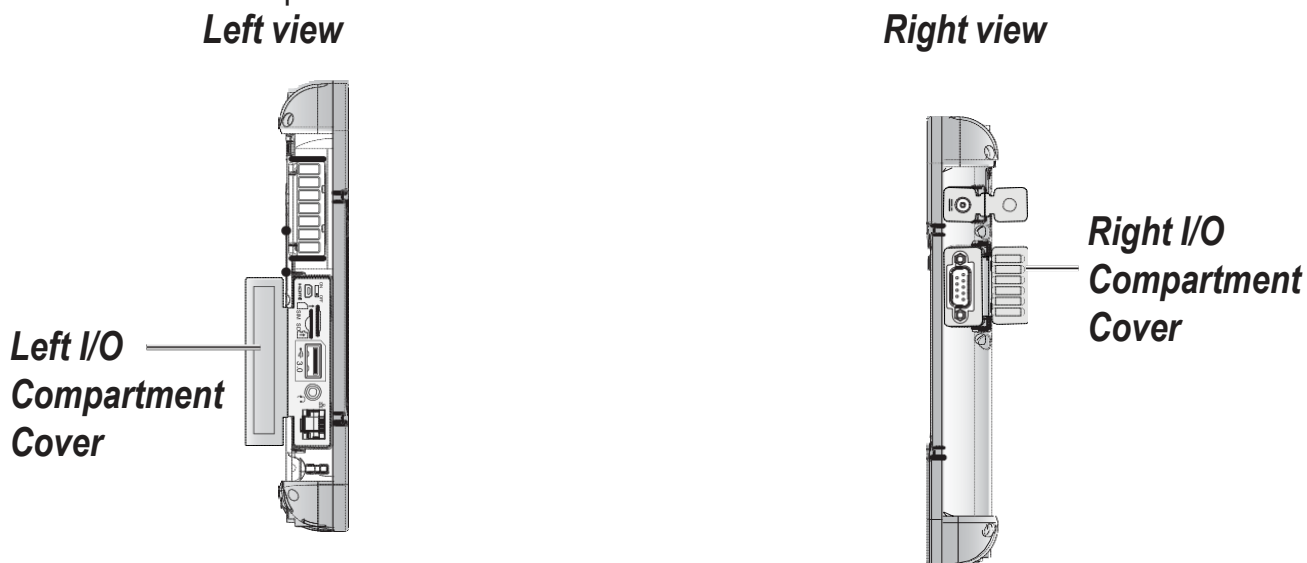

Figure 20. Side View: Locating the I/O Compartment Cover

3. Flip the I/O compartment cover and install.

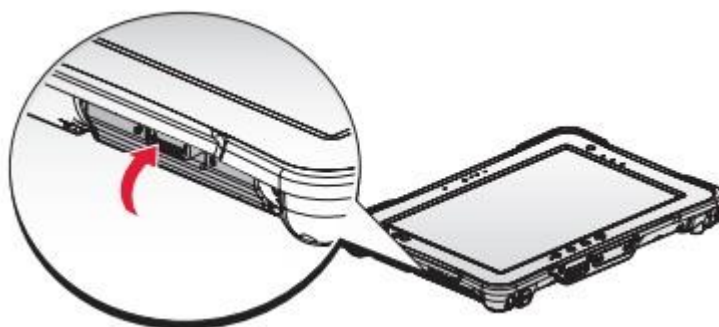

Figure 21. Installing the I/O Compartment Cover

4. Lock the latch. (Only available for the left I/O compartment cover)

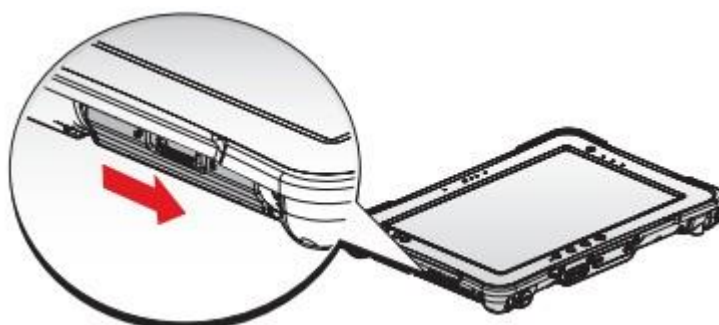

Figure 22. Locking the Latch



The I/O compartment cover must be inserted correctly to prevent internal damage to the device.

Connecting to External Cabling



To prevent damage to the device, connect all cabling and accessories before powering up the device.

Connect USB Cabling

The PX501 have one USB 3.1 Type C and one USB 3.1 Type A port for connecting USB devices, such as a digital camera, scanner, printer, modem, and mouse. The USB Type A port support USB 2.0 or USB 3.0 devices.

1. Open the left I/O compartment cover. See “Opening the I/O Compartment Cover” on page 25.
2. Connect to USB device via USB cable.

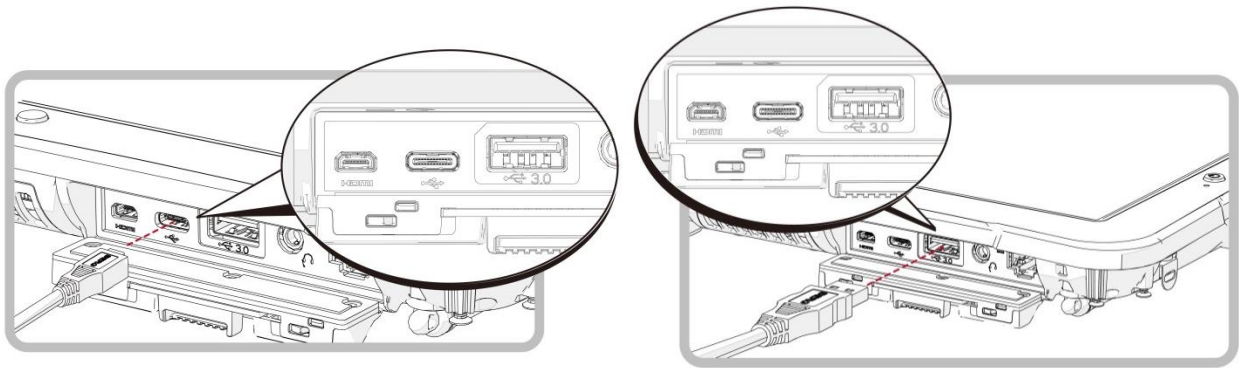

Figure 23. Connect USB Cabling

Connect Ethernet Cabling

The PX501 provides a Ethernet port for connecting Ethernet.



Use a shielded cable is required to maintain emissions and susceptibility compliance.

1. Open the left I/O compartment cover. See “Opening the I/O Compartment Cover” on page 25.
2. Connect LAN cable to Ethernet port on the PX501.

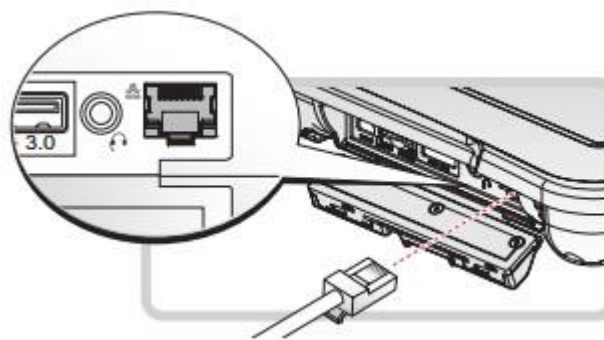

Figure 24. Connect Ethernet Cabling

Connect Audio Cabling

For higher audio quality, you can send sound through external audio devices such as speakers, headphones, or earphone using audio connector.

1. Open the left I/O compartment cover. See “Opening the I/O Compartment Cover” on page 25.
2. Connect the audio cable.

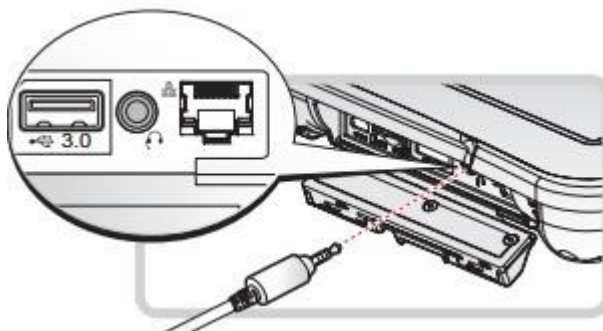

Figure 25. Connect Audio Cabling

Connect Micro HDMI Cabling

Connect to HDMI devices via micro HDMI cable.

1. Open the left I/O compartment cover. See “Opening the I/O Compartment Cover” on page 25.
2. Connect micro HDMI cable to micro HDMI port on the PX501.

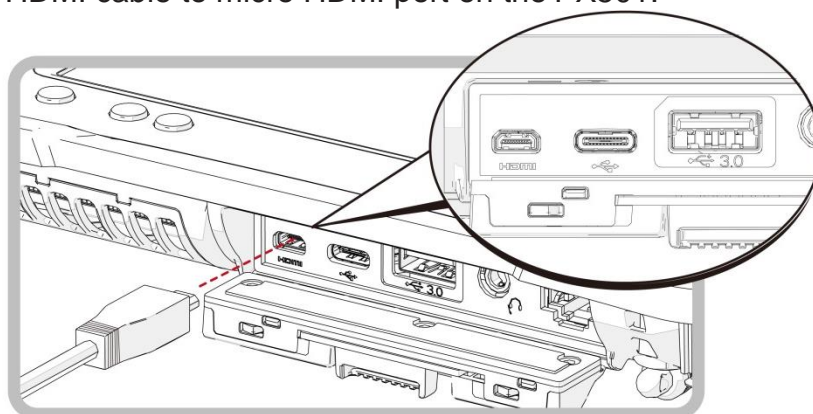

Figure 26. Connect Micro HDMI Cabling

Connect RS-232 Cabling

Connect to RS-232 devices with an RS-232 cable.

1. Open the right I/O compartment cover. See “Opening the I/O Compartment Cover” on page 25.
2. Align the RS-232 cable with the port in the device and connect it.
3. Turn the locking screws on the cable to secure it to the device.

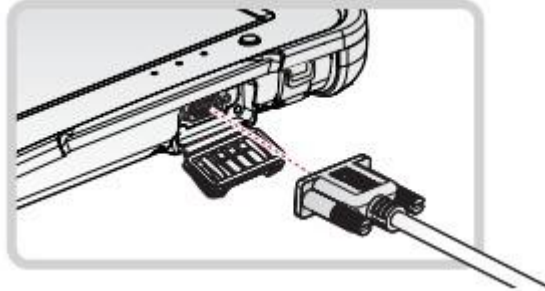

Figure 33. Connect RS-232 Cabling

Handstrap, Carrying Handle and Shoulder Strap (Optional)

The PX501 can be optionally equipped with a handstrap, a carrying handle or a shoulder strap for convenience and choice. Select the accessory that is right for your needs.

The handstrap can be installed with either the shoulder strap or the carrying handle. However, the handle and shoulder strap can not be installed together due to space constraints.

For more information, see “Connecting the Handstrap” on page 29, “Connecting the Carrying Handle” on page 32 and “Connecting the Shoulder Strap” on page 32.

Connecting the Handstrap

1. Remove the screws securing the bumpers.

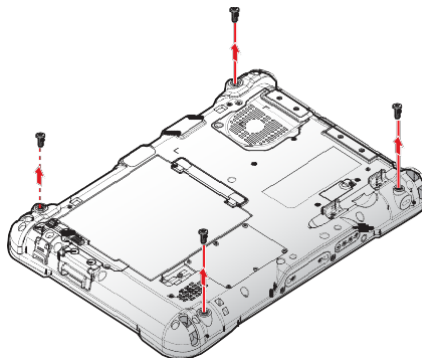

Figure 34. Removing the Screws

2. Install the D-rings.



Make sure the D-rings are tightly secured before installing the handstrap.

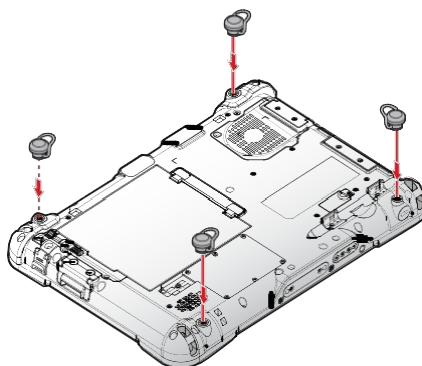

Figure 35. Installing the D-rings

3. Connect the handstrap on the D-rings.



When the handstrap is installed, the digitizer can be placed under the strap.

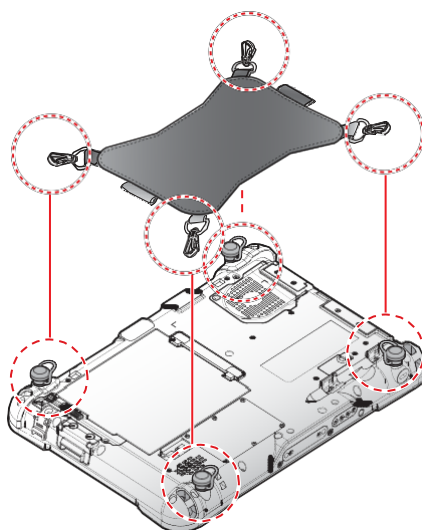

Figure 36. Connecting the Handstrap

Removing the Handstrap

1. Unlock the handstrap from the D-rings.

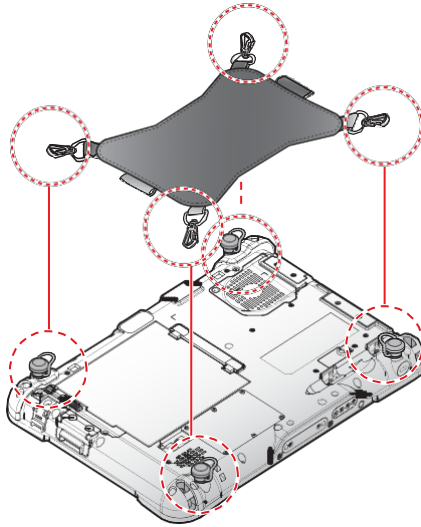

Figure 37. Removing the Handstrap

2. Remove the D-rings.

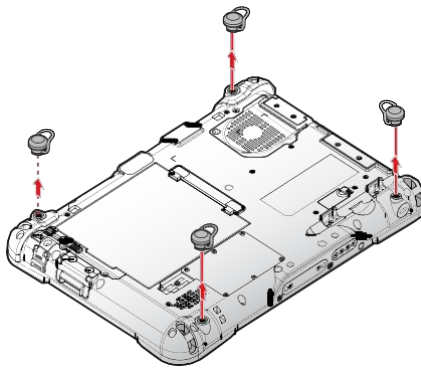

Figure 38. Removing the D-rings

3. Secure the bumper and the PX501 with screws.

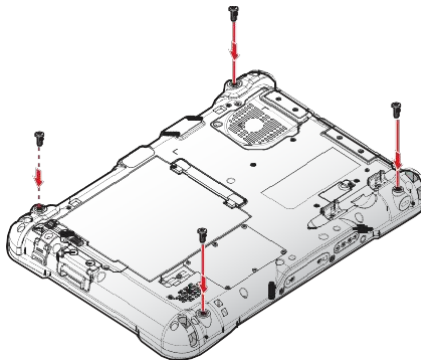

Figure 39. Securing the Screws

Connecting the Carrying Handle

1. Attach the clips to the metal loop on the bumper.

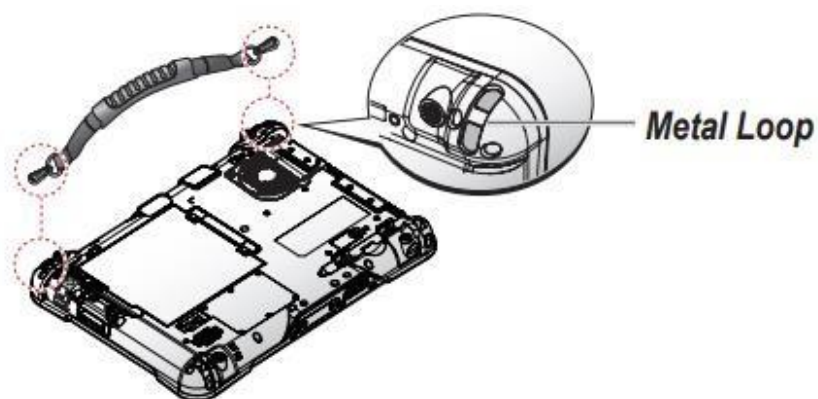

Figure 40. Connecting the Carrying Handle

Removing the Carrying Handle

1. Press in the clips to release them from the metal loop.
2. Remove the clips.

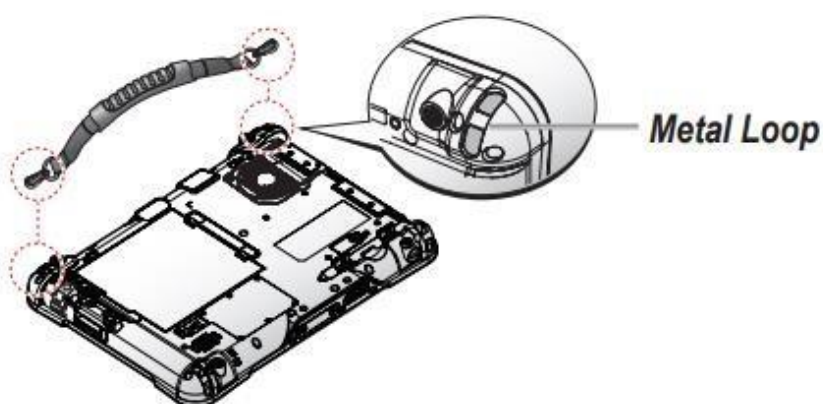

Figure 41. Removing the Carrying Handle

Connecting the Shoulder Strap

1. Attach the clips to the metal loop on the bumper.

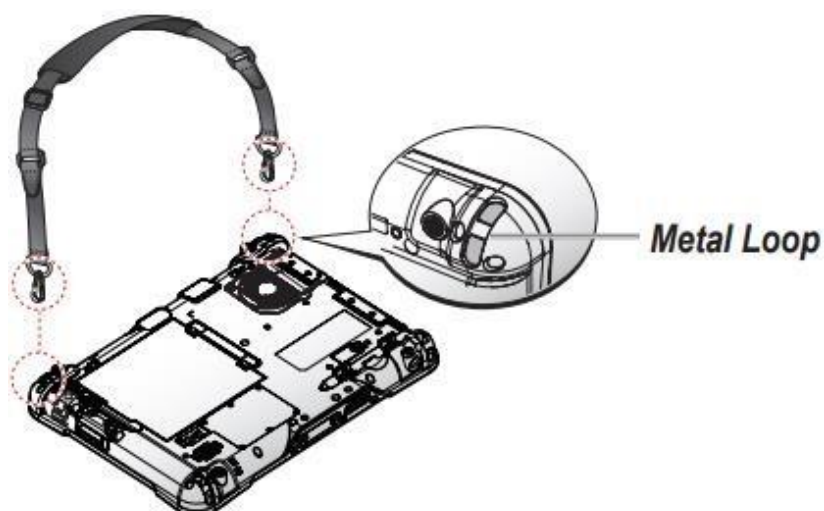

Figure 42. Connecting the Shoulder Strap

Removing the Shoulder Strap

1. Press in the clips to release them from the metal loop.
2. Remove the clips.

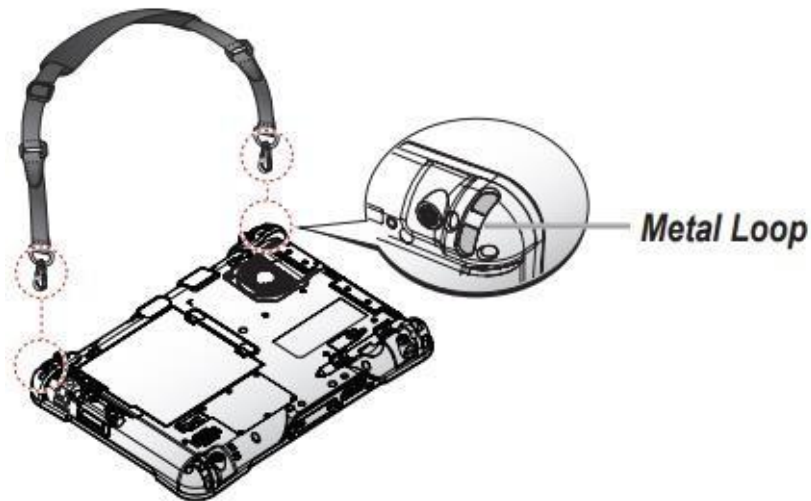

Figure 43. Removing the Shoulder Strap

Installing the Standard Battery

The following instructions are for both standard and external batteries. The external battery is an optional component. Only use components specifically designed for this device. Contact your local representative for ordering information.



Make sure the power switch is switched to ON before installing the standard/external battery. See “First Time Use” on page 17.

1. Place the device display side down on a clean work surface.
2. Locate the battery.

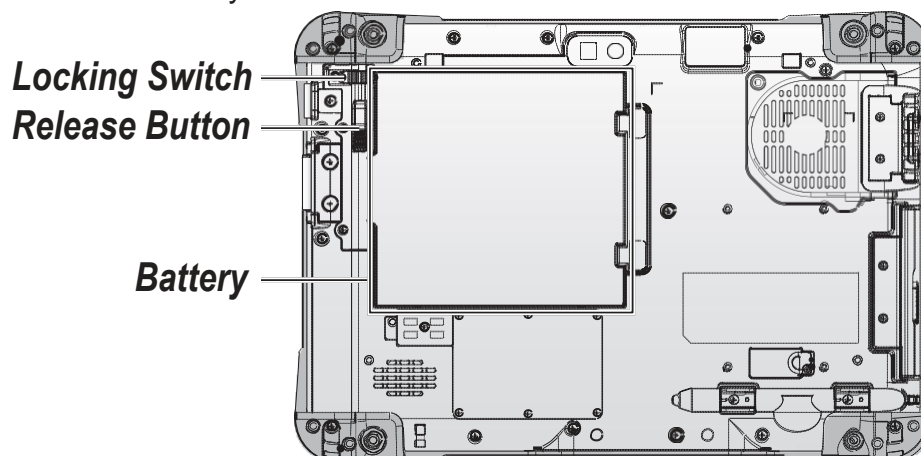

Figure 44. Rear View: Locating the Battery

3. Align the tabs on the battery with the slots on the chassis.
4. Angle the battery in place and set the tabs in the chassis slots.
5. Lower the raised end of the battery and press in place until an audible click is heard.

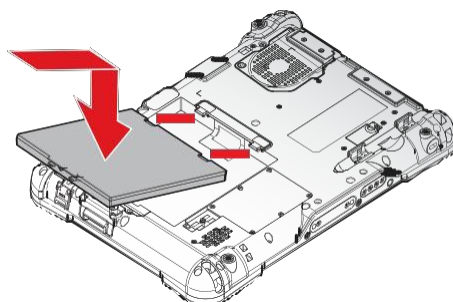

Figure 45. Installing the Battery

6. Slide the locking switch on the top-left side to lock the battery.

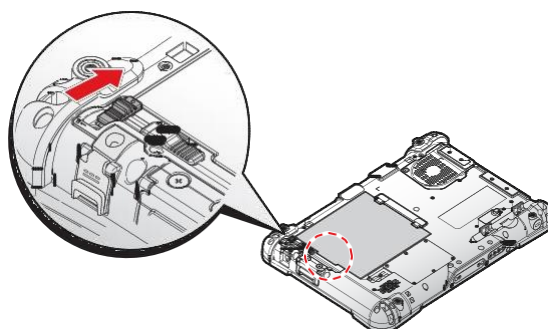

Figure 46. Locking the Battery



Make sure the latch is securely locked to prevent the battery from falling.

Removing the Standard Battery

1. Place the device display side down on a clean work surface.
2. Locate the battery.

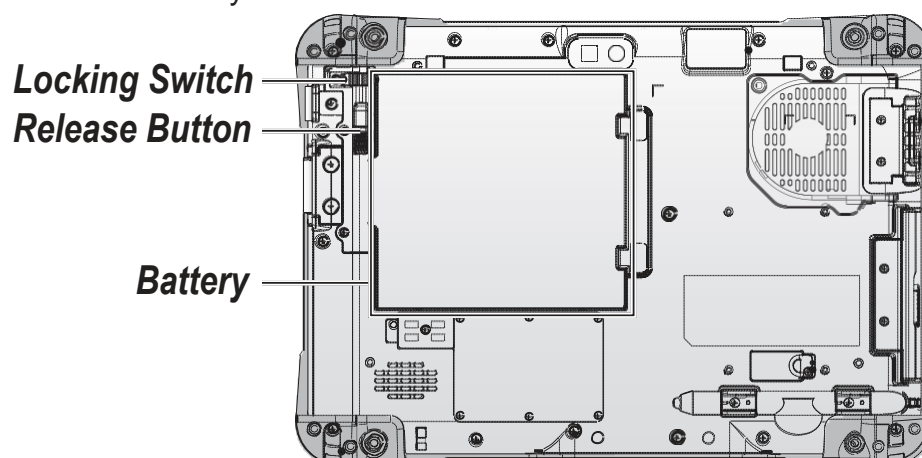

Figure 47. Rear View: Locating the Battery

3. Slide the locking switch on the top-left side to the unlock position.

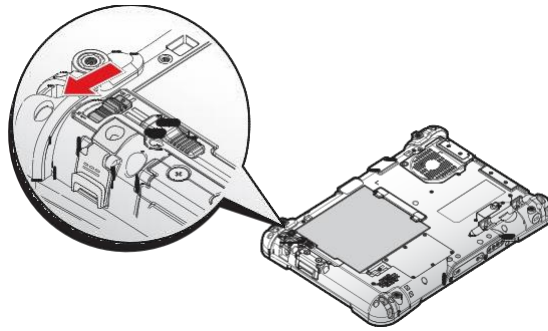

Figure 48. Unlock the Battery

4. Press and hold the release button as shown in the image to release the battery.
5. Hold the battery and angle the left side up to remove.

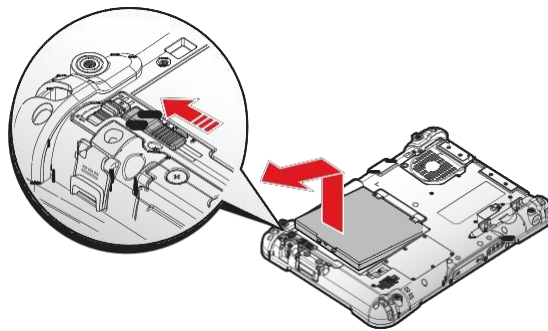

Figure 49. Removing the Battery

Connecting to a Wireless Network

Before you can make use of the PX501 wireless functions, you need to connect to a network. The following is a set of procedures for connecting to a wireless network.

1. Before beginning, make sure your Wi-Fi setting is enabled and you are within range of a wireless network. If your Wi-Fi setting is disabled, proceed to step 2.
 - Look at the Network icon located at the right side of the taskbar. If the icon displays an X in a red circle, you are not within range of a wireless network. Move to a different spot until the Wi-Fi icon changes status indicating availability to a wireless network.
2. From any screen, open the Charms bar by sliding your finger inward from the screen's right edge. The Charms bar displays along the screen's right side.
3. In the Charms bar, tap **Settings** to open the **Settings** menu.
4. In **Settings**, tap the Network icon to display the Networks connection settings.
5. The Wi-Fi menu displays. By default, the Wi-Fi menu is set to Off. Tap the bar next to Off to toggle Wi-Fi to On. This enables the Wi-Fi option.
6. Once W-Fi is enabled a listing of all available wireless networks displays. The wireless networks with the strongest signal are atop the list.

7. Select the network you want to connect to, and tap the **Connect** button. You can tap the **Connect Automatically** check box if you connect to this network frequently. If you connect to the network, you are finished with the process. The network is considered an Open unsecured network, no password is required.
8. If a password is required, type the password in the **Enter the network security key** field. Alternatively, you can also push the WPS button on your router to begin the security handshake.
9. Tap **Next** to finish the connection process.

You have successfully connected to a wireless network.

Chapter 4. Using BIOS Setup Utility

Your ruggedized tablet has a BIOS setup utility which allows you to configure important system settings, including settings for the Boot and AP menus as well as the device's basic settings--the system reads the basic settings during initialization in order to boot correctly

When to Use the BIOS Setup Utility

You need to run the BIOS Setup utility when:

- Restoring to BIOS settings to factory default
- Modifying specific hardware settings
- Modifying specific settings to optimize system performance
- Installing Windows 7 operating system

Accessing the BIOS Setup Utility



The BIOS Setup Utility screens shown in this chapter are for your reference only. The actual images or settings on your tablet computer may differ.

The BIOS Setup Utility program may have been updated after the publication of this manual.

To run the BIOS Setup Utility, use the following procedures:

1. Perform one of the following:
 - If the PX501 is powered off
Press the Power button to start up the device. The power LED lights.
Quickly press and hold the Windows Home key until the BIOS Post screen displays.
 - If the PX501 is powered on
Press the Power button to shut down the device.
Quickly press and hold the Windows Home Key until the BIOS Post screen displays.

The BIOS POST screen appears as shown.

2. From the BIOS POST screen select **App Menu** to open the BIOS Setup Utility.

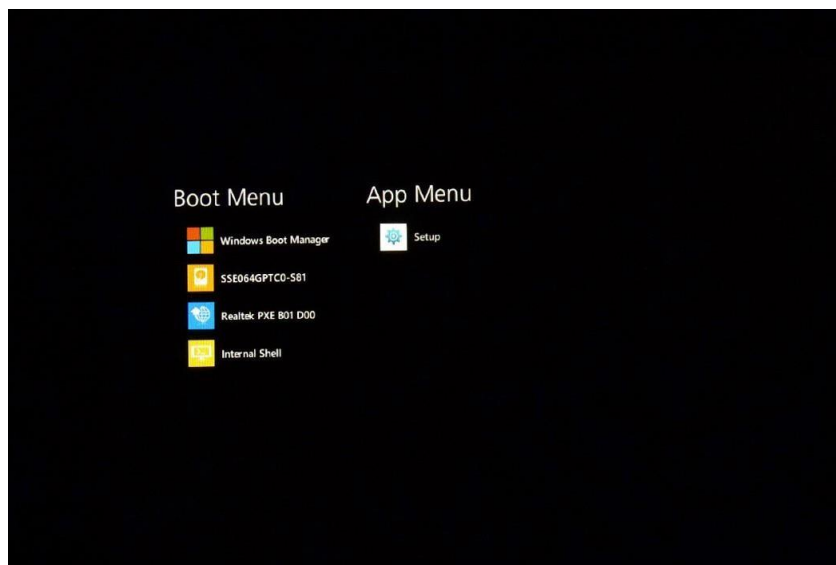

Figure 50. BIOS POST Screen

Due to the device's fast boot up and boot down time, there is only a small time frame of a few seconds between the release of the Power button and the opportunity to press the Windows Home key.

The App Menu displays.

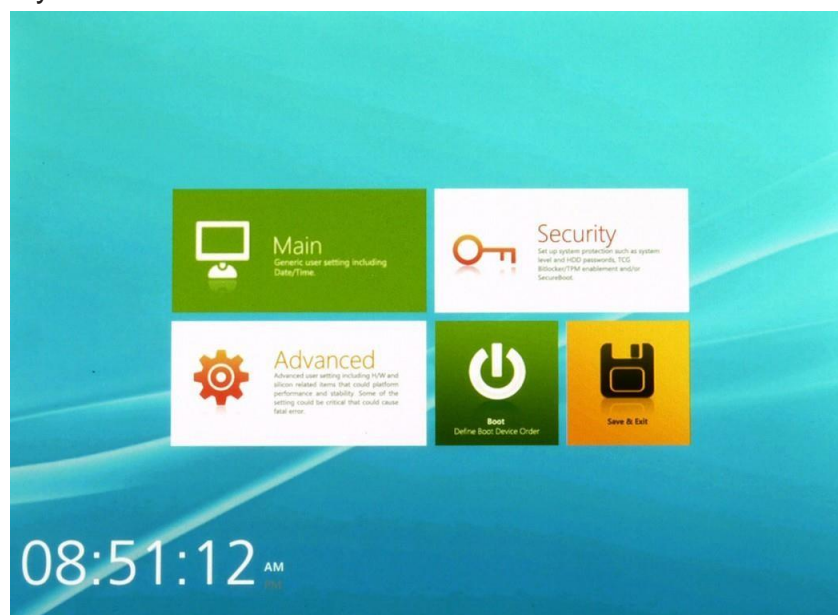

Figure 51. BIOS Setup Utility: App Menu Screen

Installation an Operating System

Setting Up a Windows 7 Installation Environment

There are several settings in BIOS that must be modified before you can install a Windows 7 operating system.

Use the following guidelines to prepare the BIOS environment:

- Step 1: Enable CSM Support
 1. Access the BIOS Setup Utility, see “*Accessing the BIOS Setup Utility*” on page 37.
 2. Navigate to **APP Menu > Main > Boot Features**.
 3. Locate the **CSM Support** setting and tap the drop-down menu to display the options.

4. Tap **Yes** to enable CSM support.

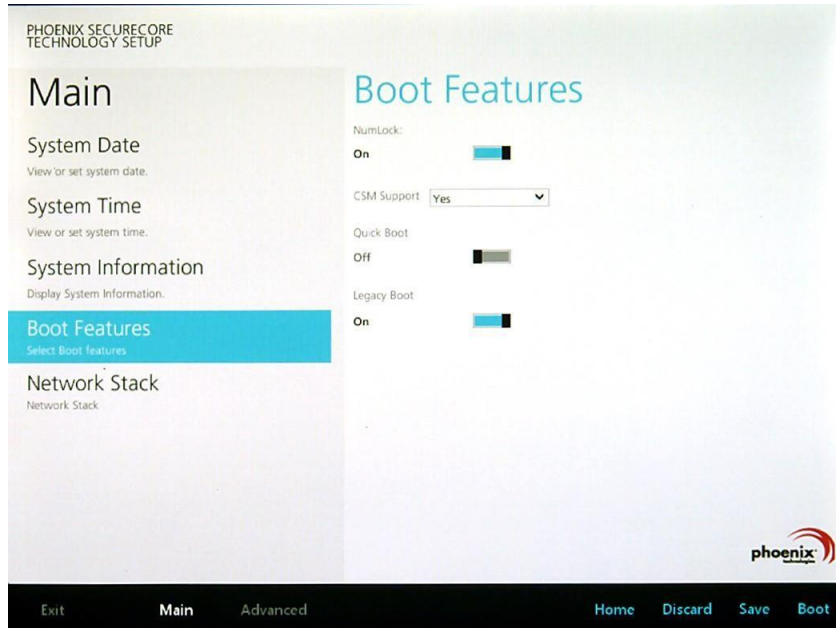

Figure 52. Main > Boot Features

■ Step 2 Enable Legacy Boot

1. Access the BIOS Setup Utility, see “Accessing the BIOS Setup Utility” on page 37.
2. Navigate to **APP Menu > Main > Boot Features**.
3. Locate the **Legacy Boot** setting and tap on the menu to select **On** enable legacy boot.

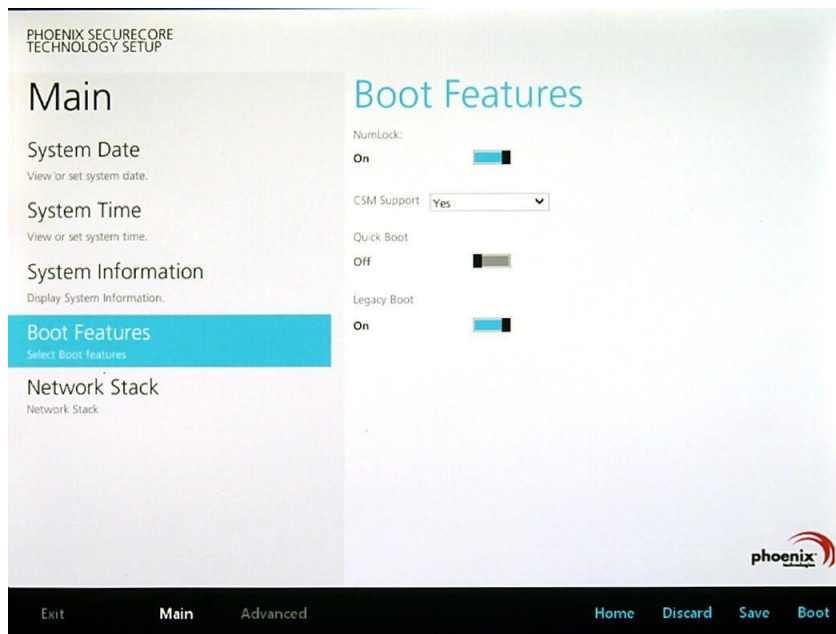

Figure 53. Main > Boot Features

- Step 3: Advanced > Miscellaneous Configuration
- Save the Settings

After you configure BIOS, you will need to save the settings.

1. Navigate to **APP Menu > Exit** and tap **Exit Saving Changes**.

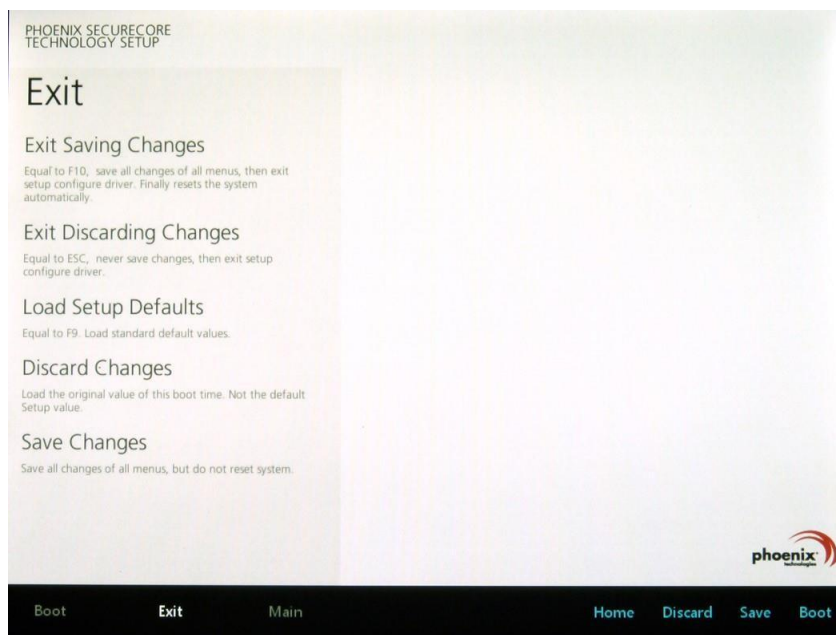

Figure 54. Exit the BIOS Utility

2. A prompt display, tap **Yes** to save the configuration.
- The BIOS settings are configured and the Windows 7 operating system can be installed.

BIOS Passwords

Setting Up a Supervisor Password

To setup a supervisor password, follow the procedure as described:

1. Go to **APP Menu > Security > Account's Password Status**.
2. Tap the **Enter** icon next to **Setup the Supervisor Password** to access the virtual keyboard.

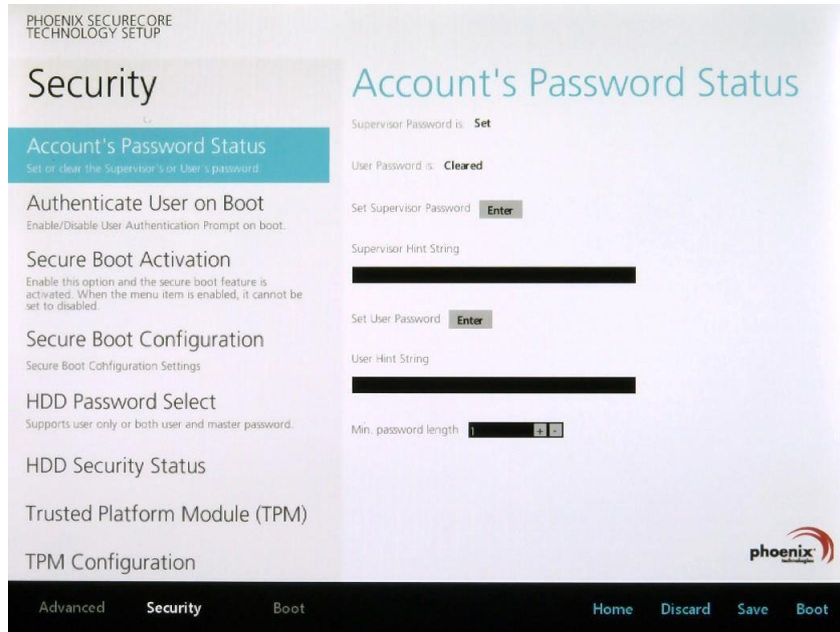

Figure 55. Security > Account's Password Status

3. Tap the password to use for the Supervisor profile and tap **Enter**.

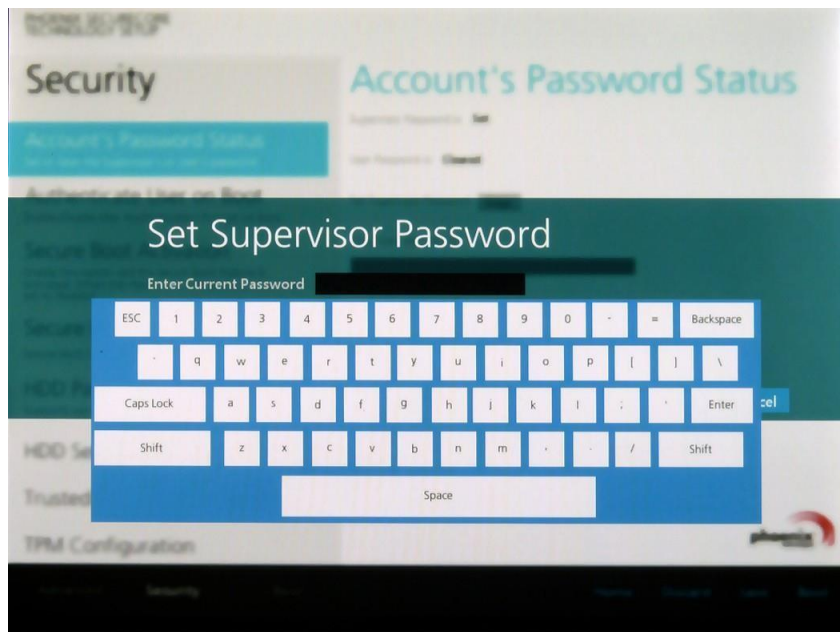

Figure 56. Set Supervisor Password

4. Verification of the password is required. Tap the same password again and tap **Enter** to confirm the new password.
5. Navigate to **APP Menu > Exit**.

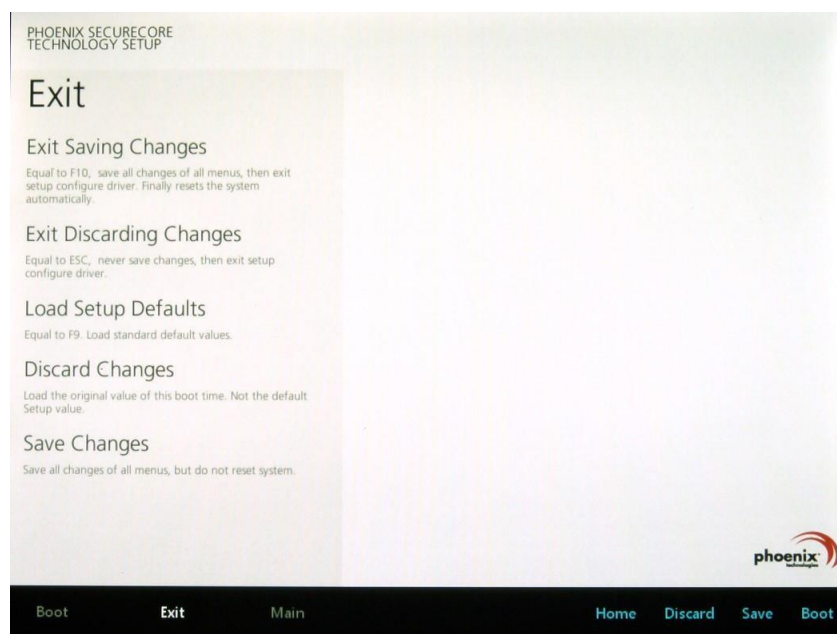

Figure 57. Exit Screen

6. Tap **Exit Saving Changes** to display the confirmation screen.
7. Tap **Yes** to save the new configuration settings.

After setting the Supervisor password, the password is required to access the BIOS Setup Utility.

Changing a Supervisor Password

1. Navigate to **APP Menu > Security > Account's Password Status**.
2. Tap the **Enter** icon next to **Setup Supervisor Password**.
3. Enter the current supervisor password.
4. Enter a new password.
5. Enter the new password again to confirm.
6. Go to **APP Menu > Exit**.
7. Tap **Exit Saving Changes** and tap **Yes** to save the configuration.

Resetting a Supervisor Password

A supervisor password can not be reset. In the event that you forget the supervisory password, you will need to reflash the BIOS to enter the BIOS menus. Refer to *"Updating BIOS"* on page 43 to reflash the BIOS.

EC and BIOS

Updating BIOS

This procedure allows you to update and reflash the system BIOS. Both procedures follow the same steps as described in the following.



Make sure to protect your device from power loss during the BIOS update procedure to prevent irreparable damage to your system's mainboard.

For this procedure, it is highly recommended to connect the device to the AC adapter to prevent a sudden loss of power during the BIOS updating process.

1. Contact your technical sales or technical representative to obtain the correct BIOS file.
2. Copy the BIOS file on to the USB device.
3. Connect the USB device to one of the device's USB ports and power on the PX501. A



USB keyboard is required for entering command.

4. Once the device is on and the Windows 8 Home screen displays, open the Charms bar by sliding your finger inward from the screen's right edge. The Charms bar displays.
5. Tap **Settings** from the displayed menus.

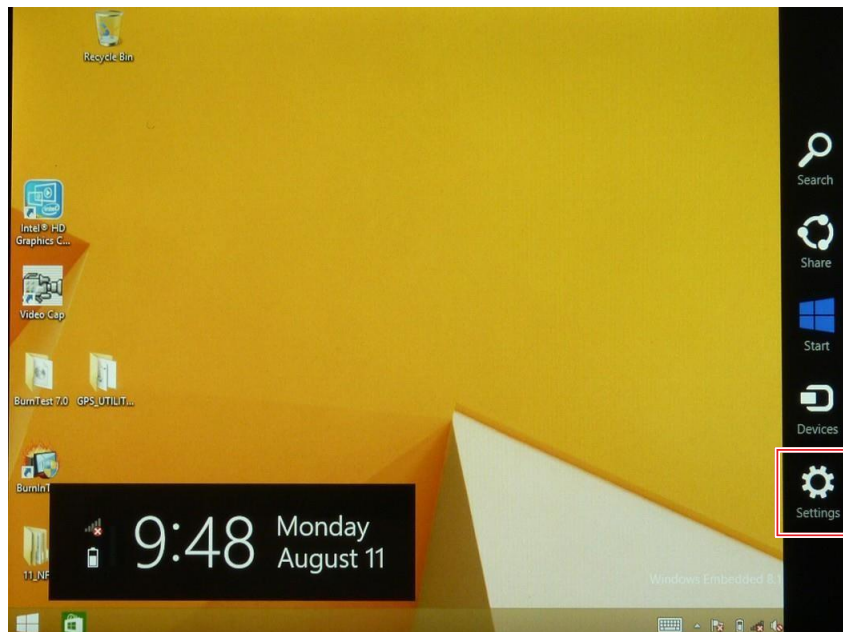

Figure 58. Charms Bar > Settings

6. Tap **Change PC settings**.

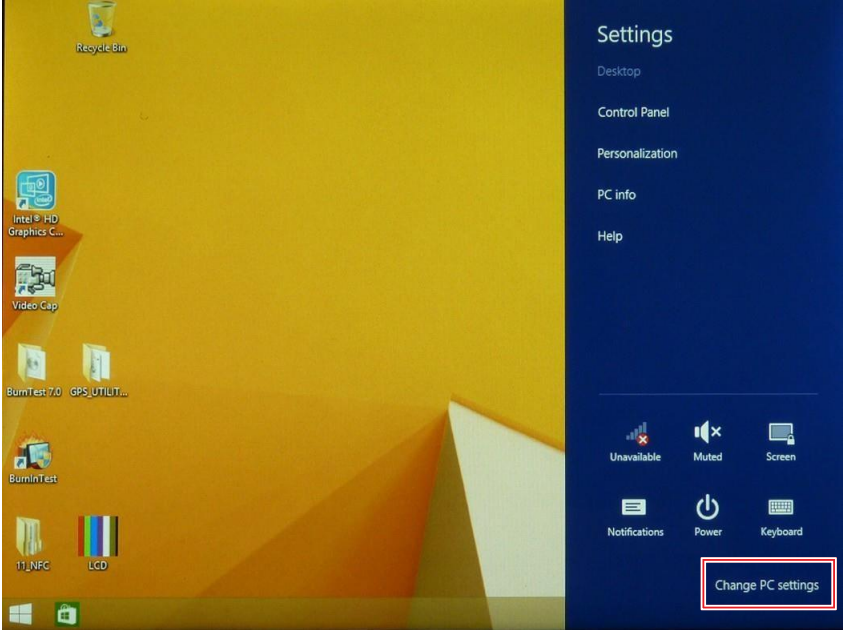

Figure 59. Change PC Settings

7. From the PC settings menu, tap **Update and recovery** to continue.

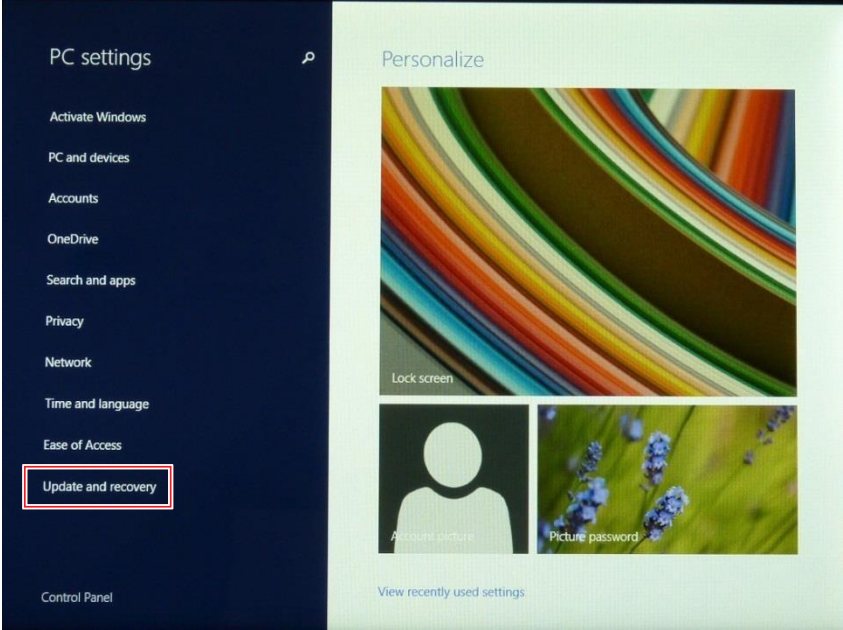

Figure 60. Update and Recovery

- From the **Update and recovery** screen, tap **Recovery**.
The **Advanced startup** option displays.

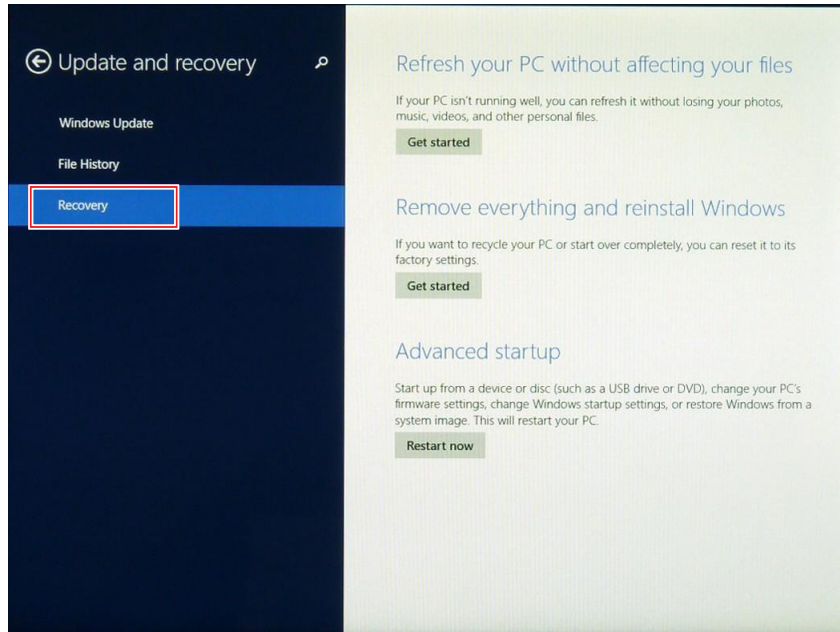

Figure 61. Recovery

- Under **Advanced startup**, tap **Restart now**.

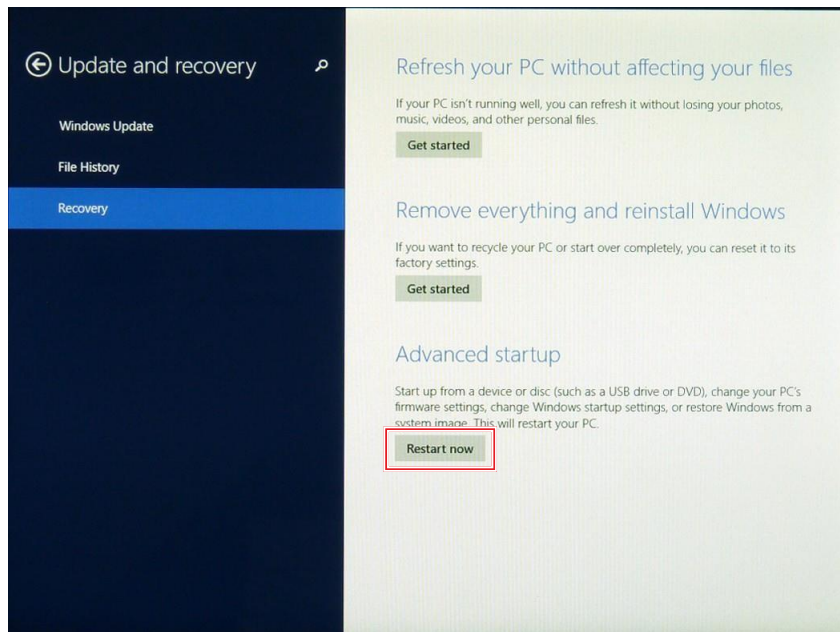

Figure 62. Restart Now

10. Tap **Use a device** to select a boot up preference.

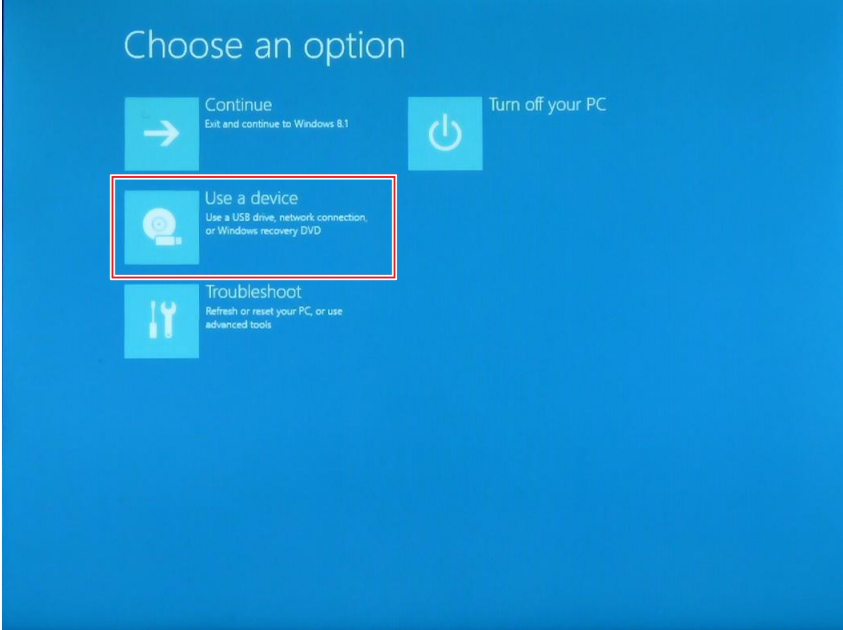

Figure 63. Use a Device

11. From the **Use a device** menu, tap **Internal Shell** to open the command screen.



Make sure connect the PX501 to the AC adapter to prevent a sudden loss of power.

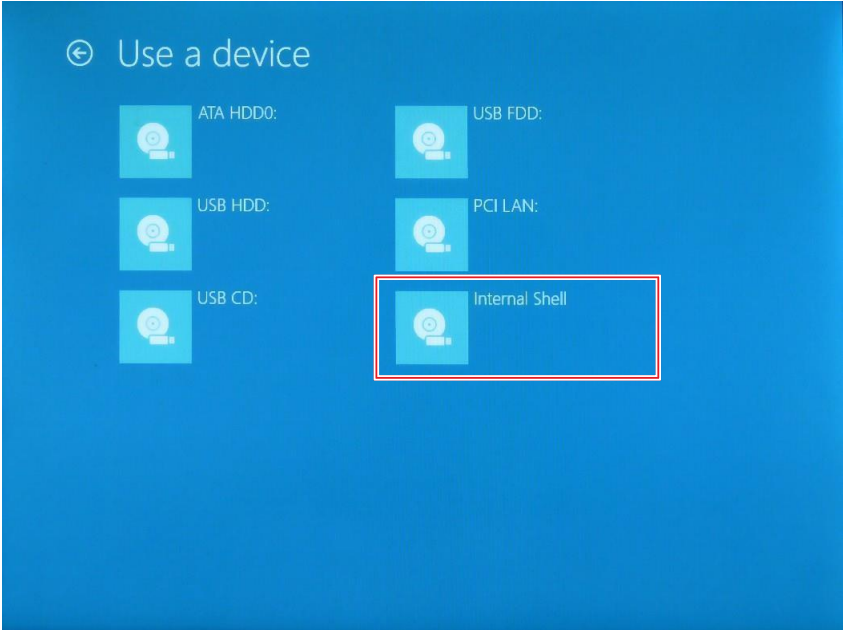

Figure 64. Internal Shell

12. In the command screen, enter `fs1 :` to select the USB device already connected to the device. The command directs you to the USB device's root menu.

```
EFI Shell version 2.31 [4660.22136]
Current running mode 1.1.2
Device mapping table
fs0 :HardDisk - Alias hd19c blk0
      Acpi (PNP0A03.0)/Pci (1310)/Sata (0,0,0)/HD (Part2.Sig632a7c85-549a-4a90-a1fc-809ca105bf3a)
fs1 :Removable BlockDevice - Alias f20a0 blk1
      Acpi (PNP0A03.0)/Pci (1410)/Usb (0,0)
blk0 :HardDisk - Alias hd19c fs0
      Acpi (PNP0A03.0)/Pci (1310)/Sata (0,0,0)/HD (Part2.Sig632a7c85-549a-4a90-a1fc-809ca105bf3a)
blk1 :Removable BlockDevice - Alias f20a0 fs1
      Acpi (PNP0A03.0)/Pci (1410)/Usb (0,0)
blk2 :HardDisk - Alias (null)
      Acpi (PNP0A03.0)/Pci (1310)/Sata (0,0,0)/HD (Part1.Sig4BE671EF-27a4-4990-8B03-86836FBBaEa7)
blk3 :HardDisk - Alias (null)
      Acpi (PNP0A03.0)/Pci (1310)/Sata (0,0,0)/HD (Part3.SigE75F2a22-F220-419B-BEC2-a05073a37FC6)
blk4 :HardDisk - Alias (null)
      Acpi (PNP0A03.0)/Pci (1310)/Sata (0,0,0)/HD (Part4.Sig2CE0675B-5200-4BC6-B761-0965185EA9B4)
blk5 :BlockDevice - Alias (null)
      Acpi (PNP0A03.0)/Pci (1310)/Sata (0,0,0)

Press ESC in 1 seconds to skip startup.nsh, any other key to continue.
Shell: _
```

Figure 65. Internal Shell Command Screen

13. If the BIOS file is in a folder and not in the root directory, navigate to the target folder.
14. Type `wf (.nsh)` and tap Enter. `wf` is the designated BIOS file.
Do not turn off your device or interfere with the reflash process until the process is complete.
15. Once the process is complete, the PX501 automatically reboots. The BIOS is now updated.

Updating EC



Connect the PX501 to the AC adapter to prevent a sudden loss of power.

1. Updating EC requires the use of the Internal Shell Command menu, refer to steps 1 to 12 of “Updating BIOS”.
2. Enter the EC source file folder.
3. In the source folder, enter `f`.
4. Do not turn off your device or interfere with the reflash process until the process is complete.
The system reboots once the process is completed.

Chapter 5. Using the DashON Utility

Overview

The DashON resident program is designed to provide near-instant access to your device's settings and configuration within a single, easy to use interface.

The following information illustrates and describes the various settings available for configuration through the DashON menus.

Important: Do not terminate or remove the DashON program manually or the ambient light sensor and the function buttons will be malfunction.

Download the latest information and documentation through the RuggON official site:

http://www.ruggon.com/en/app_search.php



Figure 70. DashON Overview

Function	Description
EXIT	Minimize DashON and return to the desktop.
Button Lock	Lock or unlock all the physical buttons except Power button.
Screen Auto Rotate	Disable or enable screen auto rotate function.
Airplane	Turn on or off the airplane mode.
Battery	Shows the battery level or charging status.
Brightness	Adjust brightness level and enable or disable auto brightness function.
Volume Control	Adjust volume level and enable or disable mute function.
GNSS	Disable or enable GNSS function.
Wi-Fi	Disable or enable Wi-Fi function.
Bluetooth	Disable or enable Bluetooth function.
Mobile Broadband	Disable or enable mobile broadband function.

Function	Description
Touch Screen Lock	Lock or unlock the touch screen.
ECO Mode	Disable or enable ECO mode to save battery life when using the device.
Power Plan	Manage how your tablet uses power.
Info Viewer	View system specifications. The menu is for display only.
Display Switch	Choose a display mode when connect to another output device.
Pass-through Switch	Switch the usage of internal antenna or external antenna on vehicle docking.
Button Setting	Pre-defined functions settings. Supports function button customizing.

Chapter 6. Troubleshooting

Use the troubleshooting tables in this section to fix problems with the Wi-Fi connection, 802.1x security, or general problems with operating the computer.



If you send the computer in for service, it is your responsibility to save the computer data and configuration. RuggON is responsible only for ensuring that the hardware matches the original configuration when repairing or replacing the computer.

Troubleshoot the Wi-Fi Connection

Use this troubleshooting table to help solve problems with your 802.11 radio connection.

- Q.** When you turn on the computer after it was suspended for a while (10 to 15 minutes or longer), it can no longer send or receive messages over the network.
- A.** Host may have deactivated or lost current terminal emulation session. In a TCP/IP direct connect network, turn off the “Keep Alive” message from host to maintain the TCP session while the computer is suspended.
- Q.** The computer is connected to the network and you move to a new site to collect data. Your computer now shows you are not connected to the network.
- A.** Move closer to an access point or to a different location to reestablish communications until you reconnect with the network.
- Q.** The computer appears to be connected to the network, but you cannot establish a terminal emulation session with the host computer.
- A.** There may be a problem with the host computer, or with the connection between the access point and the host computer. Check with the network administrator to make sure the host is running and allowing users to log in to the system.
- Q.** The computer appears to be connected to the network, but the host computer is not receiving any information from the computer.
- A.** There may be a problem with the connection between the access point and the host computer. Check with the network administrator or use your access point user’s manual.
- Q.** A network connection icon appears in the toolbar, but then disappears.
- A.** The computer may not be communicating with the intended access point. Make sure the network name matches the access point network name. The access point may not be communicating with the server. Ensure the access point is turned on, properly configured, and has 802.1x security enabled.

Troubleshoot Operating the Computer

Use this section to troubleshoot problems that may prevent you from being able to operate the computer.

Q. You press the Power button and nothing happens.

A. Make sure that power is connected to the computer.

Q. The computer appears to be locked up and you cannot enter data.

A. Restart the computer.

Call Product Support

Simple instructions please contact the dealer, contact ruggon representative, or leave a message visit the RuggON website at www.ruggon.com.

To better assist you have the following information ready:

- Configuration number
- Serial number
- Operating system, BIOS, and MCU versions
- Service pack version
- System component versions
- If you are using security, know the type and the full set of parameters

Chapter 7. Maintenance

Cleaning the Device



Danger to electric shock when cleaning or maintaining the PX501.

To avoid electric shock, turn the PX501 off and disconnect it from the power supply before cleaning or maintaining it.

Housing

- The housing of the PX501 is best cleaned with a damp cloth.
- Use compressed air, a high-pressure cleaner or vacuum cleaner may damage the surface.
- Use a high-pressure cleaner, the additional risk of water entering the PX501 may damage the electronics or touch screen.

Touch Screen

- Use neutral detergent or isopropyl alcohol on a clean soft cloth to clean the panel surface.
- Prevent using any kind of chemical solvent, acidic or alkali solution.

Returning the Device

Please put the contents in the original package gently when you need to return the PX501.

Contacting RuggON

If you experience technical difficulties, please consult your distributor or contact the technical services department:

www.ruggon.com

