



PM-522

User's Manual



©2014 RuggON Corporation. All rights reserved.

TRADEMARKS

RuggON logo is a trademark of RuggON Corporation, registered in the United States Patent and Trademark Office and in other countries. Microsoft and the Windows logo are either registered trademarks or trademarks of Microsoft Corporation in the United States and/or other countries. Microsoft products are licensed to OEMs by Microsoft Licensing, Inc., a wholly owned subsidiary of Microsoft Corporation. The Bluetooth® word mark and logos are registered trademarks owned by Bluetooth SIG, Inc. All other brand and product names are trademarks or registered trademarks of their respective owners.

Images shown in this document may vary slightly from actual products at time of shipping. Information in this manual is subject to change without notice.

Table of Contents

About This Manual

Related Information.....	1
Conventions.....	1

Basic Safety Guidelines

Maintenance and Operation Overview.....	2
Safety.....	2
Intended Use.....	2
Electrical Hazards.....	2
Safety Guidelines for Mounting.....	3
Radio Transmissions.....	4
Cleaning and Servicing.....	4
Regulatory and Certification.....	5
Lithium Battery Safety Statement.....	6

Chapter 1. Introduction

About This Guide.....	7
Unpacking the Device.....	7
Parts List.....	8
Technical Specifications.....	9
Identifying the Device.....	11
Dimensions.....	15
Touch Screen.....	16

Chapter 2. Getting Started

PM-522 Configuration Options.....	17
Installing the Bumpers.....	18
Removing the I/O Cover.....	20
Replacing the I/O Cover.....	21
Connecting to External Cabling.....	22
Charging the Battery.....	30

Chapter 3. Operation

Before First Time Use.....	33
Powering Up and Down the Device.....	34
Connecting to Network.....	35
Calibrating the Touch Screen.....	35
Using the CMOS Setup Utility.....	36

Chapter 4. Troubleshooting

Troubleshoot the Wi-Fi Connection.....	38
Troubleshoot 802.1x Security.....	39
Check 802.11 Network Status.....	39
Troubleshoot Reading Bar Codes.....	40
Troubleshoot Operating the Computer.....	42
Call Product Support.....	42
Restart Your Computer.....	43

Chapter 5. Maintenance

Cleaning the Device.....	43
Returning the Device.....	43
Contacting RuggON.....	43

About This Manual

The PM-522 User's Manual provides instruction for qualified personnel to follow when setting up a new PM-522 device.

This document is intended for use by qualified personnel to compliment the training and expertise, not to replace it.

Related Information

Current information and manuals are available for download at the following website:

<http://www.ruggon.com>

Conventions

Bolded or underlined text is used to emphasize the designated information.



A Note is used to provide additional information for the device or settings.



A Caution is used to warn against potential hazards or to caution against unsafe practices.



A Warning is used to identify immediate hazards for property damage, injury or death.

Basic Safety Guidelines

The following safety guidelines are intended to help protect the user from injury and prevent damage to the hardware.

- » Do not place anything on the AC adapters power cable and make sure the cable is not located where it can be tripped over or stepped on.
- » Do not cover the AC adaptor as it reduces the cooling
- » Do not use the AC adapter while it is inside the carrying case.
- » Use only the AC adapter, power cord, and batteries that are approved for use with the device. Use of another type of battery or AC adapter may cause risk of fire or explosion.
- » If you use an extension cable with the AC adapter, ensure that the total ampere rating of all products plugged in to the extension cable does not exceed the ampere rating of the extension cable.
- » If the device is moved between environments with very different temperature and/ or humidity ranges, condensation may form on or within the device. Avoid damaging the device by allowing sufficient time for the moisture to evaporate before using the device.
- » When disconnecting cables, pull on the connector or on its strain relief loop, not on the cable itself. When pulling out or plugging in the connector, keep it evenly aligned to prevent bending the connector pins.

Intended Use

The PM-522 rugged tablet is equipped with multi-functional terminals for stationary and mobile applications in industrial environments such as logistics, warehousing, fleet management, manufacturing and the automotive industry.

Read the safety guidelines throughoghly before starting any servicing on the device. Read the guidelines before powering up the device, and keep this document for later use.

The operator is solely responsible for any damage resulting from unauthorized modifications to the device.

Unintended Application Use

The device is not designed for use in life-support systems or critical safety/security systems where system malfunction can lead to the direct or indirect endangerment of human life. The operator is fully responsible for using the device in these situations.

Maintenance and Operation Overview

The PM-522 is designed and manufactured according to strict controls and following the stated safety regulations. The following list identifies incorrect operating uses of the PM-522. Incorrect use of the PM-522 can lead to hardware damage, safety issues and possible risk to personnel health:

- » The PM-522 is improperly or incorrectly installed;
- » The PM-522 is under operation by untrained personnel;
- » The PM-522 is not maintained as recommended;
- » The PM-522 is not used as intended.

Safety

To prevent injury and damage, read the following safety guidelines prior to operating the device. The manufacturer assumes no liability for any and all damages arising from misuse or noncompliance with these guidelines.

Electrical Hazards

Installing Easy-access Separators

The PM-522 is not equipped with separators (switches) that are accessible from the outside. To quickly disconnect the device from the power supply in emergencies:

Install an easy-access separator such as a switch or circuit breaker close to the device;

Ensure that the separator separates all power cables.

Only connect to SELV Circuits

The PM-522 should only be connected to Safety Extra Low Voltage (SELV) circuits.

- » Do not connect/disconnect any cables during thunderstorms;
- » Do not connect/disconnect the PM-522 cables during thunderstorms.

Cleaning/Serviceing: Power down the PM-522

- » Disconnect the PM-522 from power before cleaning or servicing it.

Power Adapter

Contact an authorized service personnel for repairs to the power pack. In the event of a blown fuse after replacing the fuse, contact an authorized service personnel to avoid electrical shock.

Laying Cables

- » Cables must be laid in accordance with local and state regulations.
- » Ensure that the power cable is laid properly and properly secured.

Use only Supplied Power Cables

RuggON power cables meet industrial requirements for low-temperature flexibility, UV resistance, and oil resistance. Use only supplied power cables from RuggON.

If other power cables are used, the following may apply:

- » The operator is solely responsible for the resulting damage;
- » All RuggON warranties are void.

Environmental Hazards

Do not use the PM-522 in locations near/with flammable gases or vapor.

The use of electrical equipment in explosive environments can be dangerous.

- » Turn off the device when near a gas station, fuel depot, chemical plant or a place where blasting operations take place.

Environmental

Ambient Temperature

The PM-522 operates on the basis of a passive cooling concept which internal waste heat is released via the housing surface and requires fresh airflow in the environment.

- » Operating the PM-522 with no fresh cooling air may cause overheating and damage to the device.
- » The operating environment should not be enclosed to prevent the cool air being heated by the heat waste from the device.

Connecting and Disconnecting External Devices

To prevent the considerable damage, the PM-522 and the external device should be disconnected from power when connecting/disconnecting excluding USB devices.

Only Use Authorized Accessories

Only use the supplied cables, power packs and other accessories that have been tested and approved by RuggON. Contact your local distributor for further information.

Radio Transmissions

Permitted Transmission Power

Follow the national regulations for the maximum permitted transmission power.

The operator is solely responsible for this type of operation.

Radio Frequency Limited Locations

Considering the radio frequency limitation in hospitals and aircraft, the PM-522 can only be installed with permission.

Industrial computers may affect the function of implanted medical devices such as pacemakers and may cause malfunction. Always keep a distance of at least 20cm between a pacemaker and an industrial computer to minimize the risk of interference.

Cleaning and Servicing

- » Disconnect the PM-522 from power before cleaning or servicing.
- » Never clean the PM-522 with compressed air, a pressure washer or a vacuum cleaner.
- » If necessary, clean the housing of the PM-522 with a damp cloth.
- » Clean the touch-screen with a nonabrasive cloth.

Regulatory and Certification

FCC

This equipment has been tested and found to comply with the limits for a Class B digital device, pursuant to part 15 of the FCC Rules. These limits are designed to provide reasonable protection against harmful interference when the equipment is operated in a commercial environment. This equipment generates, uses, and can radiate radio frequency energy and, if not installed and used in accordance with the instruction manual, may cause harmful interference to radio communications. Operation of this equipment in a residential area is likely to cause harmful interference in which case the user will be required to correct the interference at his own expense.

However, there is no guarantee that interference will not occur in a particular installation. If this equipment does cause harmful interference to radio or television reception, which can be determined by turning the equipment off and on, the user is encouraged to try to correct the interference by one or more of the following measures:

- Reorient or relocate the receiving antenna.
- Increase the separation between the equipment and receiver.
- Connect the equipment into an outlet on a circuit different from that to which the receiver is connected.
- Consult the dealer or an experienced radio/ TV technician for help.

CAUTION:

Any changes or modifications not expressly approved by the grantee of this device could void the user's authority to operate the equipment.

This device is operation in 5.15 – 5.25GHz frequency range, then restricted in indoor use only, Outdoor operations in the 5.15 – 5.25GHz is prohibit.

This device is slave equipment; the device is not radar detection and not ad-hoc operation in the DFS band.

Labeling requirements

This device complies with Part 15 of the FCC Rules. Operation is subject to the following two conditions: (1) this device may not cause harmful interference, and (2) this device must accept any interference received, including interference that may cause undesired operation.

RF Exposure Information (SAR)

This device meets the government' s requirements for exposure to radio waves. This device is designed and manufactured not to exceed the emission limits for exposure to radio frequency (RF) energy set by the Federal Communications Commission of the U.S. Government.

The exposure standard employs a unit of measurement known as the Specific Absorption Rate, or SAR. The SAR limit set by the FCC is 1.6 W/kg. Tests for SAR are conducted using standard operating positions accepted by the FCC with the EUT transmitting at the specified power level in different channels.

The highest SAR value for the device as reported to the FCC is **0.57** W/kg when placed next to the body

CE Marking

This product has passed the CE test for environmental specifications when shielded cables are used for external wiring. We recommend the use of shielded cables. Please contact your local representative for ordering information.

This product has passed the CE test for environmental specifications. Test conditions for passing included the equipment being operated within an industrial enclosure. In order to protect the product from being damaged by ESD (Electrostatic Discharge) and EMI leakage, we strongly recommend the use of CE-compliant industrial enclosure products.

RTTE Directive

This tablet complies with the essential requirements of the R&TTE Directive 1999/5/EC.

CB

This device complies with the IEC 60950-1:2005+A1.

Lithium Battery Safety Statement



Lithium battery inside. Danger of explosion if battery is incorrectly replaced. Replace only with same or equivalent type recommended by battery manufacturer.

Chapter 1. Introduction

The PM-522 is a rugged Tablet computer. The PM-522 fully supports wireless data communications with 802.11, Bluetooth, GPS and GLONASS for wireless data communications.

The PM-522 is a rugged 10.4” tablet computer capable of 1024 x 768 resolution. The anti-reflection tempered capacitive touch panel is capable of sunlit and hyper dimming for day and night mode readability. The illuminated keyboard is designed to compliment a user friendly experience during night mode operations.

The PM-522 supports the following operating systems:

- » Windows® 8.1 Industry Professional
- » Windows® 7 Professional
- » Windows® Embedded Standard 8
- » Windows® Embedded Standard 7 Professional
- » Linux

About This Guide

The PM-522 User Manual provides instruction for qualified personnel to use as a guide for setup of the device. This document is not intended to replace the training and expertise of the end-user.

Unpacking the Device

Before you begin the installation or configuration process make sure to inspect all components and accessories. Contact your representative if there are any missing or damaged items.

Parts List

The PM-522 unit includes the below accessories. Other accessories are sold and ordered separately. For help, contact your local RuggON sales representative.

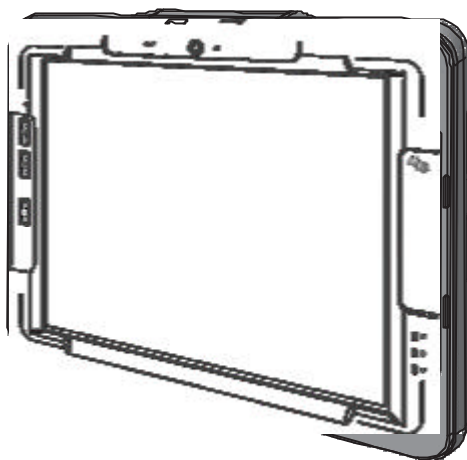

PM-522



Rubber Bumpers

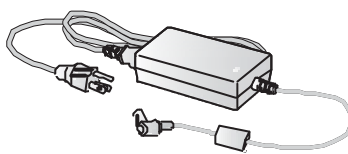

Power Adapter

Mini USB to RJ45 Dongle



2-Point Shoulder Strap

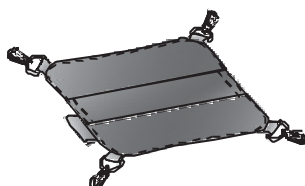

4-Point Handstrap



Stylus



Hitch D-rings
(attaching straps)

Technical Specifications

Table 1. Technical Specifications

Item	Description
Display	10.4-inch LED Backlight, 1024 (W) x 768 (H) XGA
Touch screen	10-finger Capacitive Touch Screen
Brightness	700nits
CPU	Intel® Atom™ Bay Trail-I E3827; 1.75GHz (8W)
Operating System	Windows® 8.1 Embedded Pro 64bits
RAM	DDR3L@1333MHz 4GB RAM
Storage	mSATA SSD 64GB (option for 128GB/256GB)
Battery	Internal unswappable battery: 7.4V 3800mAh Li-polymer
Power supply	AC 100V ~ 240V, 50~60Hz input; 19VDC@3.42A, 65W, 19DC-in
Dimensions	W x H x L 203.6 mm (8") x 26.5 mm (1.04") x 275.4 mm (10.84")
Weight	1.1 kg (2.43 lbs)
Wireless	
WLAN	1 x Wi-Fi IEEE 802.11 a/b/g/n/ac
Bluetooth	1 x Bluetooth 4.0
Sensor	
Light sensor	x1
G sensor	x1
I/O	
Docking	32-pin
DC-IN Jack	x1
Audio jack	x1; Headphone / Microphone combo
USB 2.0	x1; Type A
USB 3.0	x1; Type A
Ethernet	x1; Micro USB to RJ-45 dongle
Security	
TPM	TPM 1.2
BIOS On/Off for I/Os	Yes

Item	Description
Data Collection	
GPS	YES
NFC	YES
Camera	<ul style="list-style-type: none"> » Front: 2.0 Mega-Pixels camera » Rear: 5.0 Mega-Pixels camera with LED auxiliary light and Auto-focus
Barcode Scanner	Optional snap-on module
Mag Stripe Reader	Optional snap-on module
Smart Card Reader	Optional snap-on module
Rugged Specifications	
Drop	183 cm (72.05"), 26 drops on plywood
MIL-STD 810G	<ul style="list-style-type: none"> » Vibration (MIL -STD-810G Method 514.6 Category 4 Fig 514.6C-3) » Drop (MIL-STD-810G Method 516.6 Procedure IV) » Mechanical shock (MIL-STD-810G method 516.6 Procedure I) » Operation and storage temperature (MIL-STD-810G Method 501.5 and 502.5) » Humidity (MIL-STD-810G Method 507.5)
IP rating	IP65
Operating Temp range	-20° C (-4° F) to +50° C (122° F) (MIL -STD-810G Method 501.5 and 502.5)
Storage Temp range	-30° C (-22° F) to +60° C (140° F) (MIL -STD-810G Method 501.5 and 502.5)
Humidity	5-95% without condensation (MIL-STD-810G Method 507.5)

Identifying the Device

Overview

Figure 1. Overview

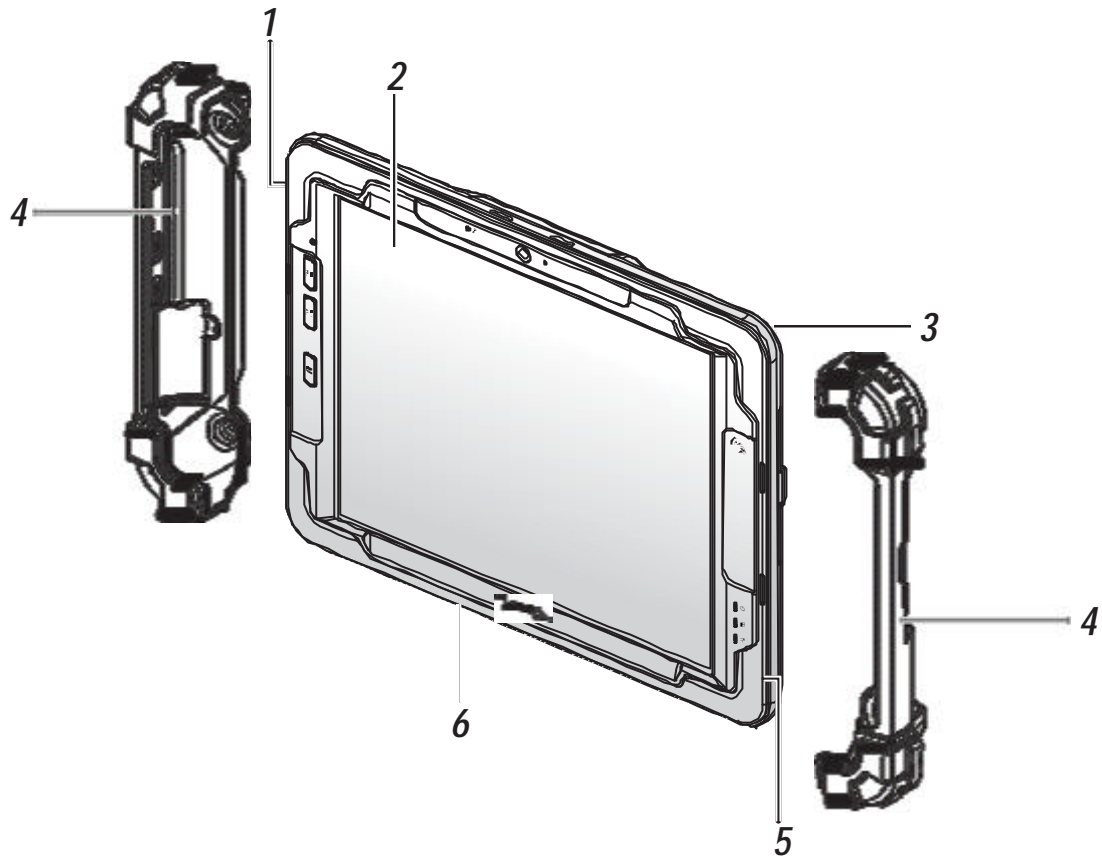

Table 2. Overview

No	Item	Description
1	Left view	See “Side View” on page 13 for further information.
2	Front view	See “Front View” on page 11 for further information.
3	Rear view	See “Rear View” on page 14 for further information.
4	Rubber bumpers	Easy to grip rubber bumpers enable the rugged tablet to withstand shocks and drop for use in demanding environments.
5	Right view	See “Side View” on page 13 for further information.
6	Bottom view	See “Bottom View” on page 12 for further information.

Front View

Figure 2. Front View

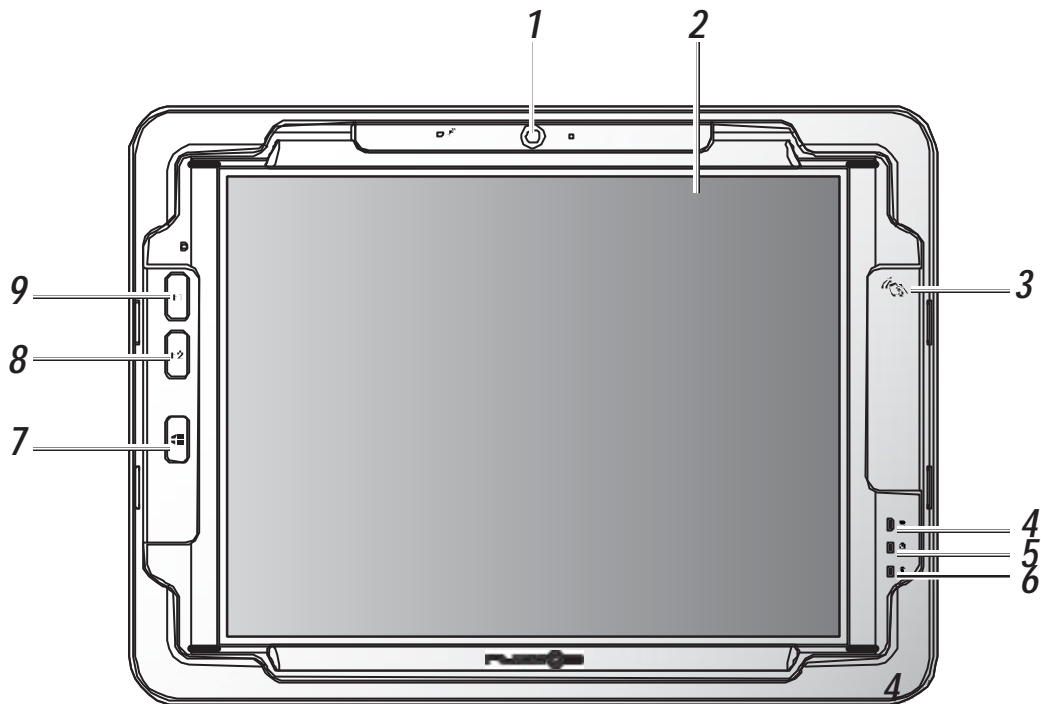

Table 3. Front View

No	Item	Description
1	Front camera	2.0 Mega-Pixels camera.
2	Touch screen	Anti-reflection tempered 5-wire resistive touch panel.
3	NFC key	For detecting NFC devices.
4	Power LED	The Power LED lights when the device is on or when the battery is being charged.
5	Storage LED	The Storage LED lights when the device is working.
6	Wi-Fi LED	The Wi-Fi LED lights to indicate Wi-Fi is enabled.
7	Home key	Windows® 8 home key.
8	F2 key	Programmable function key.
9	F1 key	Programmable function key. Note: If Barcode Scanner is installed, press F1 key to scan.

LED Status

Table 4. LED Status

Item	Status	Description
Power	Green: On	Power on / not charging
	Green: Blinking	Sleep mode / not charging
	Green: Off	Power off
	Orange: On	Power on / charging
	Orange: Blinking	Sleep mode / charging
Storage	White: On	Accessing SSD
	White: Off	No activity
Wi-Fi	White: On	Wi-Fi on
	White: Off	Wi-Fi off

Bottom View

Figure 3. Bottom View

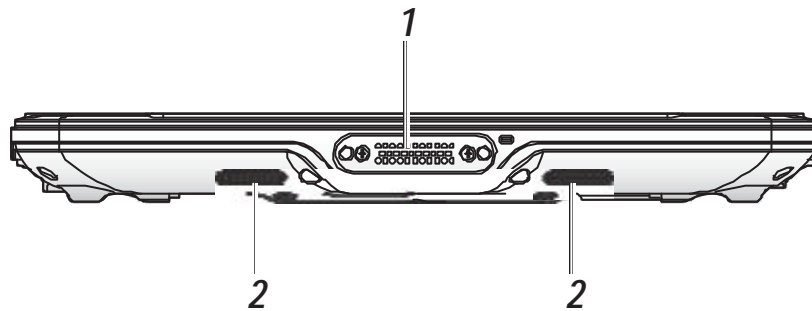

Table 5. Bottom View

No	Item	Description
1	Docking connector	32 pin connector for docking onto a station.
2	Speakers	2 x 2W waterproof, front mounted speakers.

Side View

Figure 4. Side Views

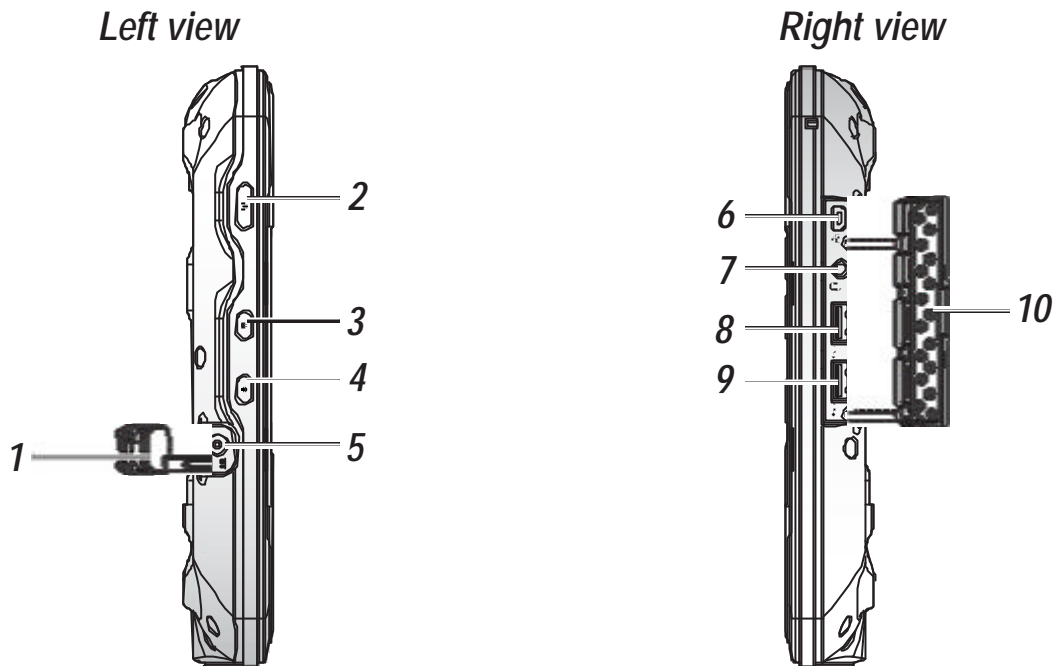

Table 6. Side View

No	Item	Description
1	DC-IN cover	Open to access the DC-IN jack.
2	Power key	Turns the PM-522 on or off.
3	Lock key	Lock all the keys except for the Power and Lock keys.
4	RF setting key	Show Windows 8 Charm Bar.
5	DC-IN jack	Insert power connector to charge battery.
6	Micro USB	Connect to Ethernet via micro USB to RJ45 doungle.
7	Audio IN	Connect a headphones or external speakers.
8	USB 3.0	Connect USB devices to the PM-522.
9	USB 2.0	Connect USB devices to the PM-522.
10	I/O compartment cover	Open to access the I/O ports.

Rear View

Figure 5. Rear View

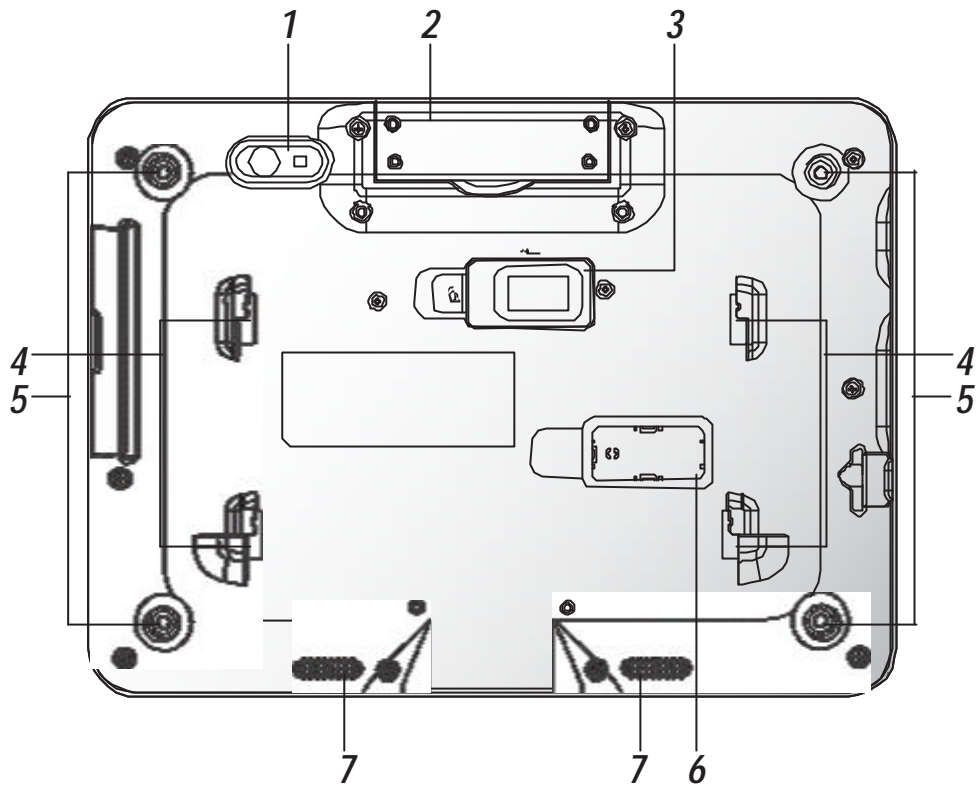

Table 7. Rear View

No	Item	Description
1	Rear camera	5.0 Mega-Pixels camera with LED auxiliary light.
2	Add-on cover	Open to access SIM port.
3	External battery connector cover	Open to access external battery connector. The external battery is optional.
4	External battery bracket slots	Align with the external battery bracket when installing.
5	Securing holes	Secure the bumpers and the D-rings for the handstrap and shoulder strap.
6	Battery connector cover placeholder	Place cover here when installing an external battery.
7	Speakers	2 x 2W waterproof, rear mounted speakers.

Dimensions

The following image lists the device dimensions without add-ons (mm/inches).

Figure 6. Front View Dimensions

Figure 7. Side View Dimensions

Figure 8. Rear View Dimensions

Touch Screen



Always use the point of the stylus for tapping or making strokes on the touch screen.

Never use an actual pen, pencil, or sharp/abrasive object on the touch screen.

The stylus is used as if it were a pen or pencil. Touch the screen with the tip of the stylus then remove the stylus from the screen.

After each use, replace the stylus in the stylus holder for proper care and to preserve the life of the stylus.

Using a stylus is similar to moving the mouse pointer then left-clicking icons on a desktop computer screen.

The following actions are available through the use of the stylus:

- » Open applications
- » Choose commands in menu
- » Select options in dialog box or drop-down menu
- » Drag the scroll bar
- » Drag across the text to select content
- » Place the cursor in a text box before typing

A right click is generated by tapping the mouse icon in the system tray. After tapping, the mouse icon highlights the right button of the icon in red. The next touch screen tap is treated as a right click. The mouse icon returns to the left button highlighted in red so subsequent taps are treated as left clicks.

Chapter 2. Getting Started

This section provides an outline of the steps necessary to setup a new PM-522. A detailed guide follows the listed items, see as follows.



It is recommended to installing or remove accessories on a clean, well-lit work surface. To protect yourself and the device from electrostatic discharge, wear anti-static wrist straps or place the device on an anti-static mat.

PM-522 Configuration Options

Date and Time

Use the Windows interface to set date, time, and timezone.

- » Category view: **RF key > Control Panel > Clock, Language and Region > Date and Time**
- » Classic view: **RF key > Control Panel > Date and Time**

Power Management

Use the Windows interface to set power management options.

- » Category view: **RF key > Control Panel > Hardware and Sound > Power Options**
- » Classic view: **RF key > Control Panel > Power Options**

Speaker Volume

Use the Windows interface to control speaker volume.

- » Category view: **RF key > Control Panel > Hardware and Sound > Sound**
- » Classic view: **RF key > Control Panel > Sound**

Connect Bluetooth Devices

Restart/Shutdown

Use the Windows interface to restart or shut down the PM-522.

- » Restart: **RF key > Power > Update and restart**
- » Shut down: **RF key > Power > Update and shut down**

Installing the Bumpers

The bumpers provide the PM-522 protection from minor damage with easy access to all keys and ports.



Warranty is void if rubber bumpers are not properly installed.

1. Align the screw holes on the left bumper with the screw holes on the PM-522.



The left bumper fits over three keys (left side panel) and the DC-IN compartment.

2. Install the left bumper to the PM-522. If the display's protective film is in the way, lift it up slightly to allow for proper installation.

Figure 9. Installing the Left Bumper

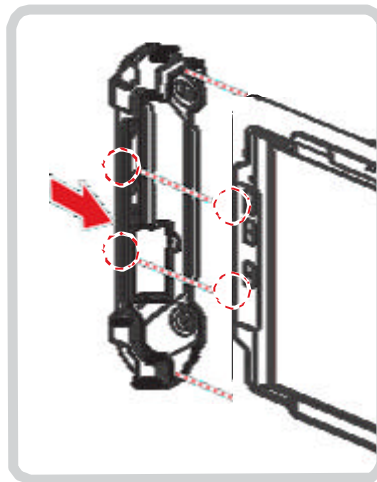

3. Align the screw holes on the right bumper with the screw holes on the PM-522.



The right bumper fits over the I/O port compartment.

4. Install the right bumper to the PM-522. (Flip up a little protective film if necessary)

Figure 10. Installing the Right Bumper

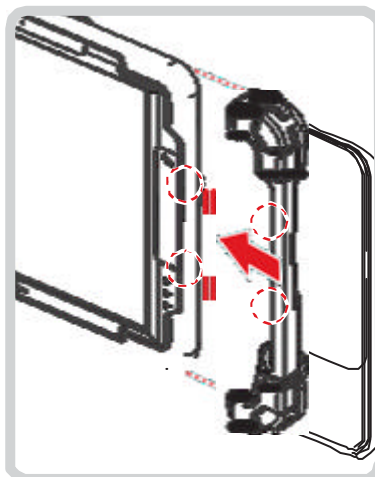



Once the rubber bumpers are installed, it is recommended to not remove them.

5. Secure the bumpers and the PM-522 with screws.

Figure 11. Securing the Screws

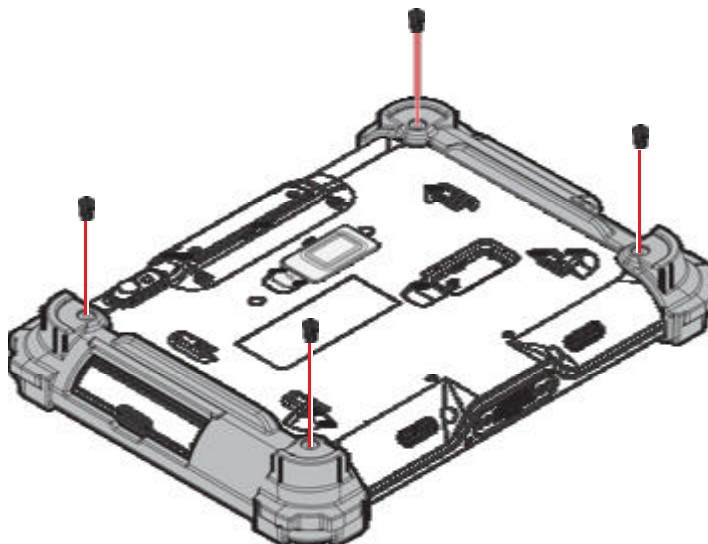

Removing the I/O Cover

1. Place the device display side down on a clean work surface.
2. Locate the I/O cover.

Figure 19. Rear View: Locating the I/O Cover

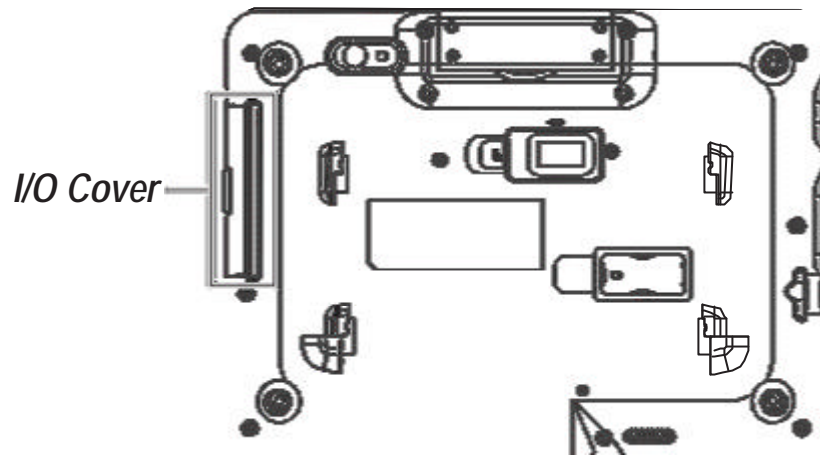

3. Flip the I/O cover and pull out the I/O cover.

Figure 20. Opening the I/O Cover

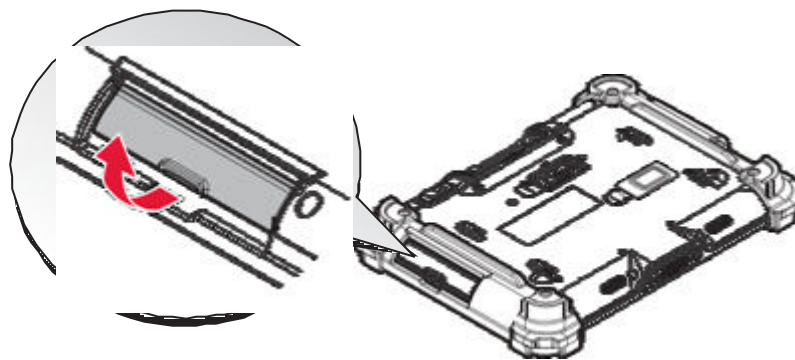

Replacing the I/O Cover

1. Place the device display side down on a clean work surface.
2. Locate the I/O cover.

Figure 21. Rear View: Locating the I/O Cover

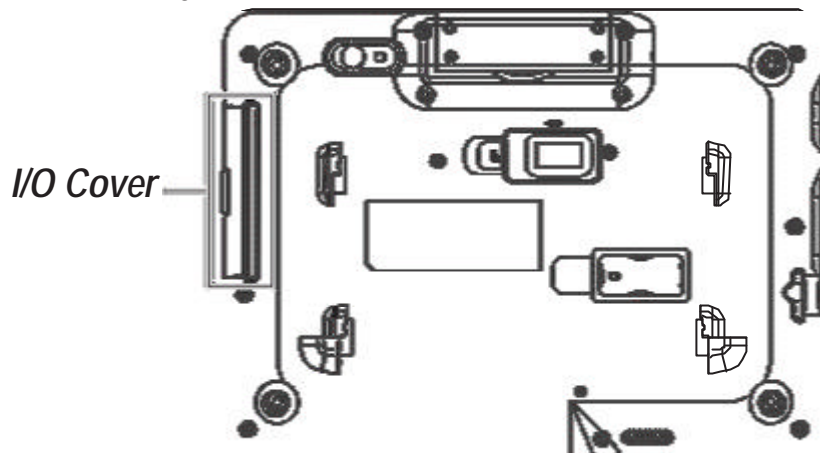

3. Align the plastic tab on the I/O cover with the PM-522.
4. Flip the I/O cover and install.

Figure 22. Installing the I/O cover

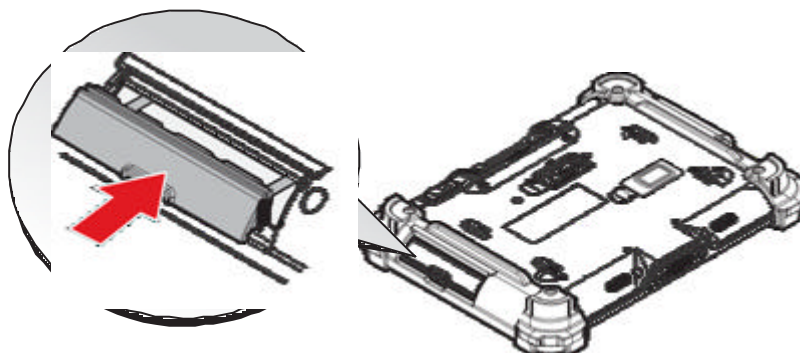

I/O cover is not be closed well may damage the PM-522.