

3. Secure the bumper and the PM-522 with screws.

Figure 31. *Securing the Screws*

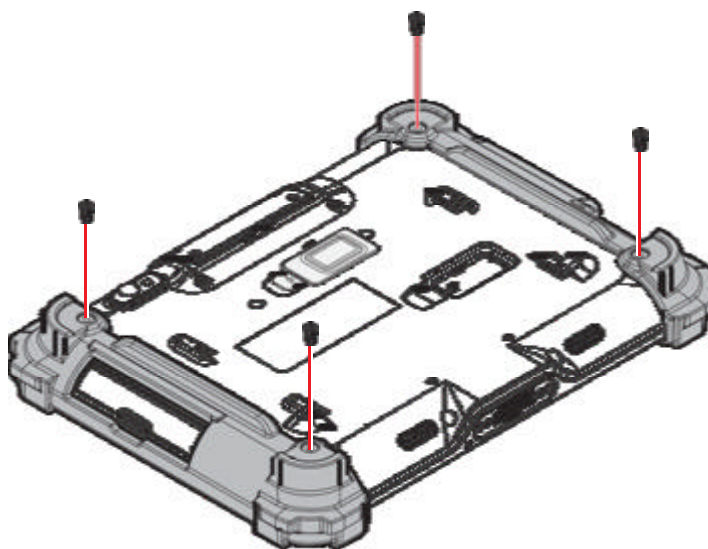

Connecting the Shoulder Strap

1. Remove the screws securing the bumpers.

Figure 32. *Removing the Screws*

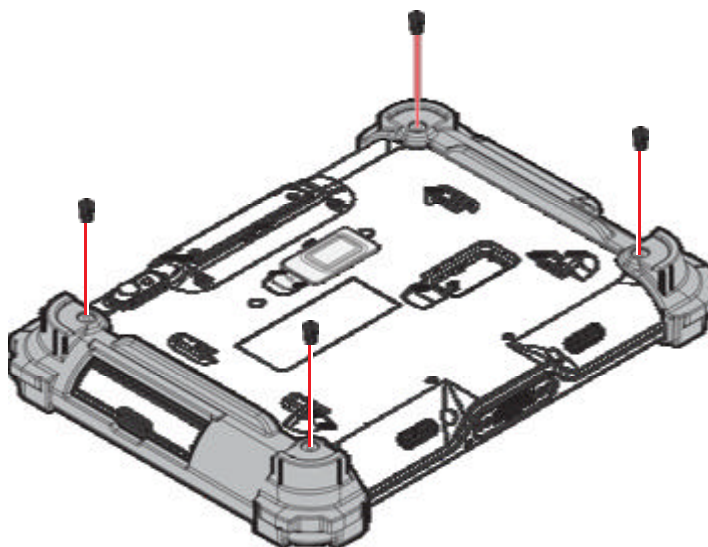

2. Install the D-rings.



Make sure the D-rings are tightly secured before attaching the shoulder strap.

Figure 33. Installing the D-rings

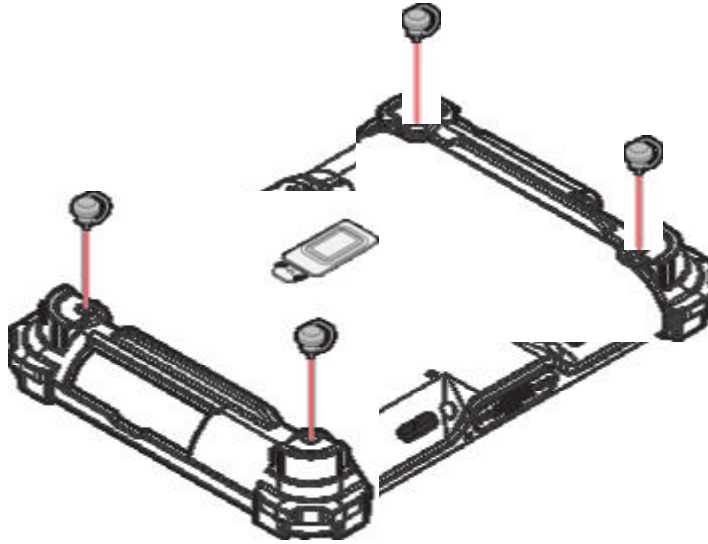

3. Attach the clips to the D-rings to attach the shoulder strap.

Figure 34. Connecting the Shoulder Strap

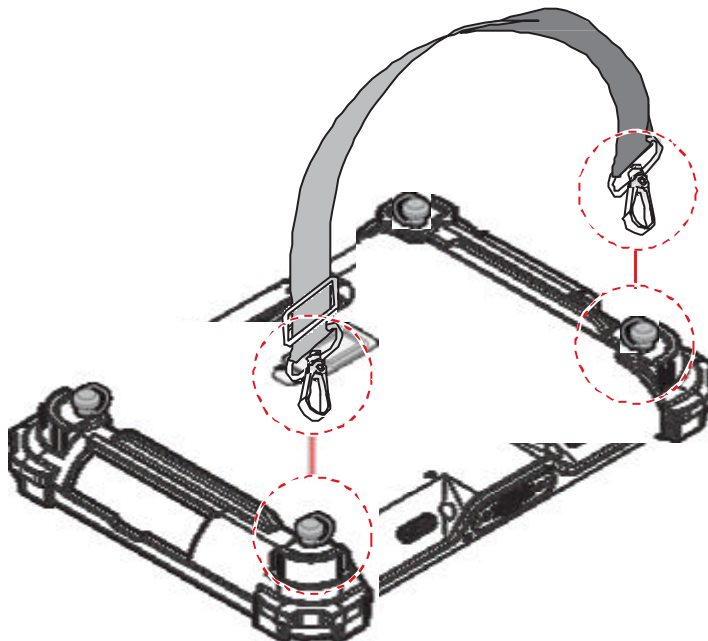

Removing the Shoulder Strap

1. Press in the clips to release them from the D-rings.
2. Remove the clips.

Figure 35. Removing the Shoulder Strap

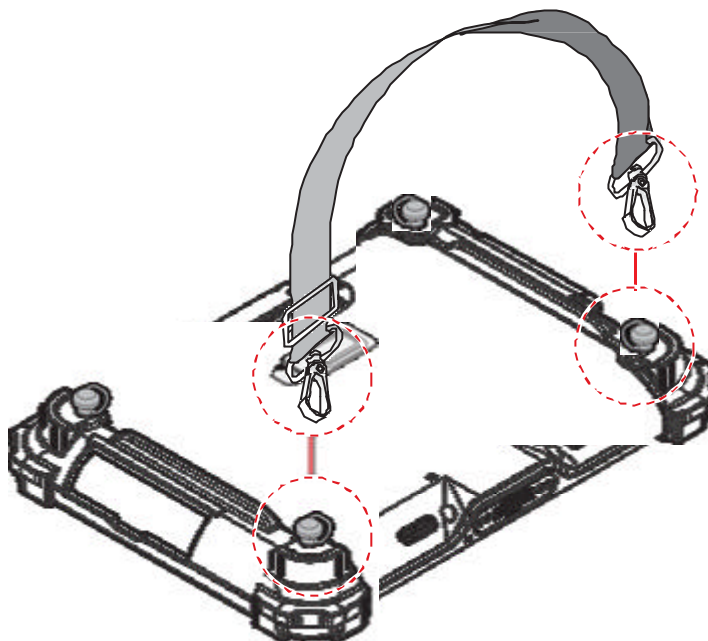

3. Remove the D-rings.

Figure 36. Removing the D-rings

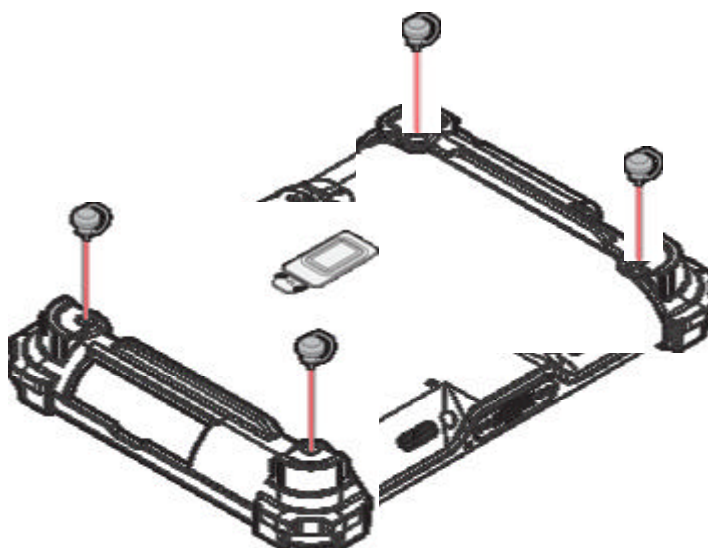

4. Secure the bumper and the PM-522 with screws.

Figure 37. Securing the Screws

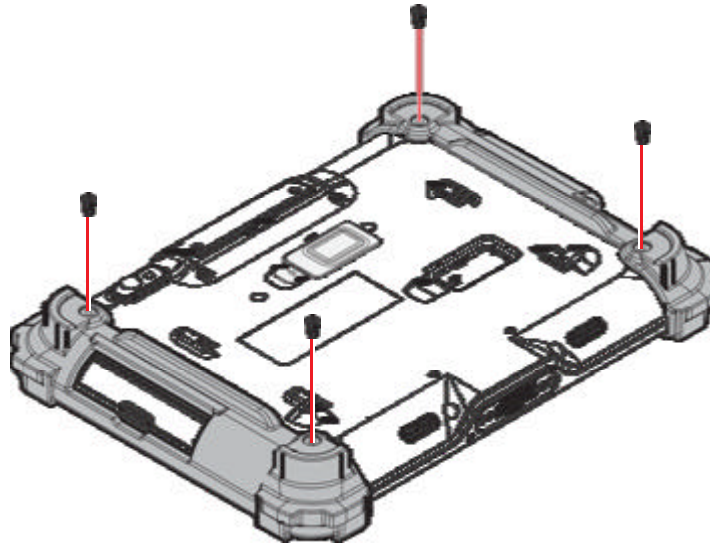

Charging the Battery

When you use the AC adapter to connect your PM-522 to a power outlet, the internal battery will automatically begin to recharge.

While the battery is charging, the Power LED will be active. When the battery is fully charged, the Power LED is lit a solid green.

1. Flip open the DC-IN cover to expose the DC-IN jack.

Figure 38. Opening the DC-IN Cover

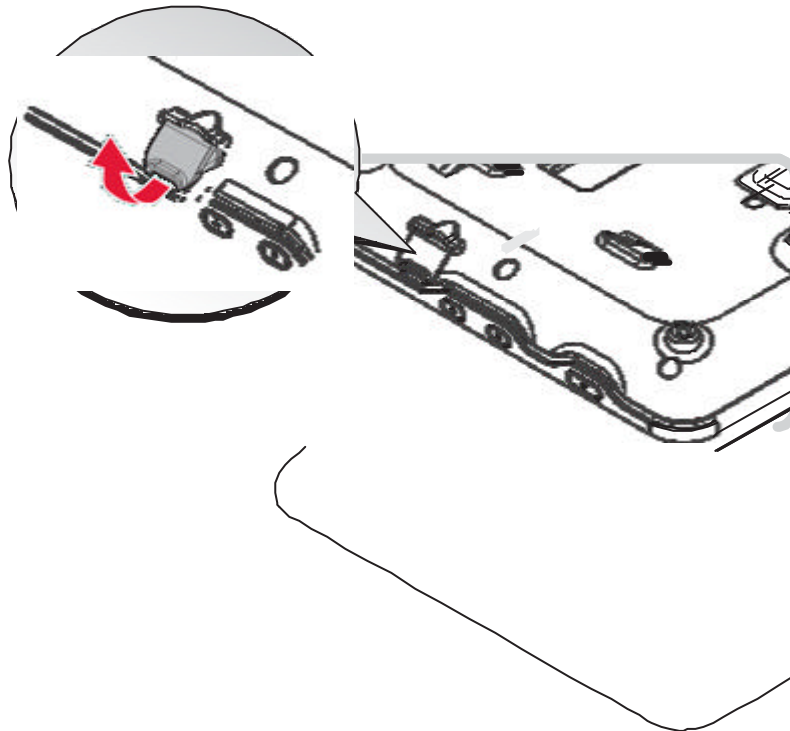

2. Connect the AC adapter to the DC-IN port.

Figure 39. Connecting the AC Adapter

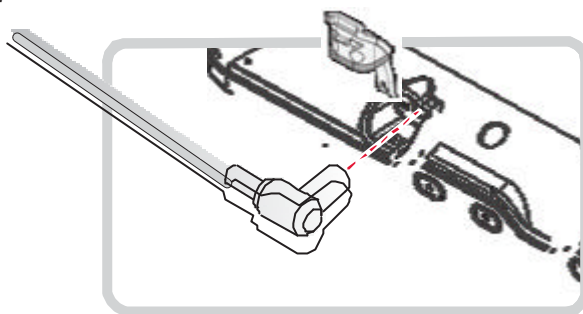

3. Tap the battery icon on the right bottom side of Windows 8 screen. Check to see if the charging process is active.

Figure 40. Battery Information

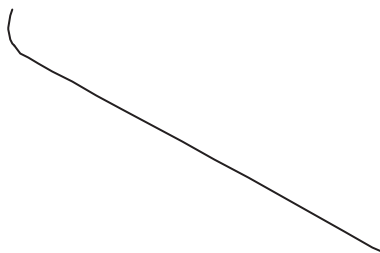

After charging the battery, disconnect the AC adapter and close the DC-IN cover.

1. Align the plastic tab on the DC-IN cover with the compartment.

Figure 41. Align the DC-IN Cover

2. Insert one end of the cover first and angle the cover to seat it in place.