

Tenoning Jig (Model 34-183)

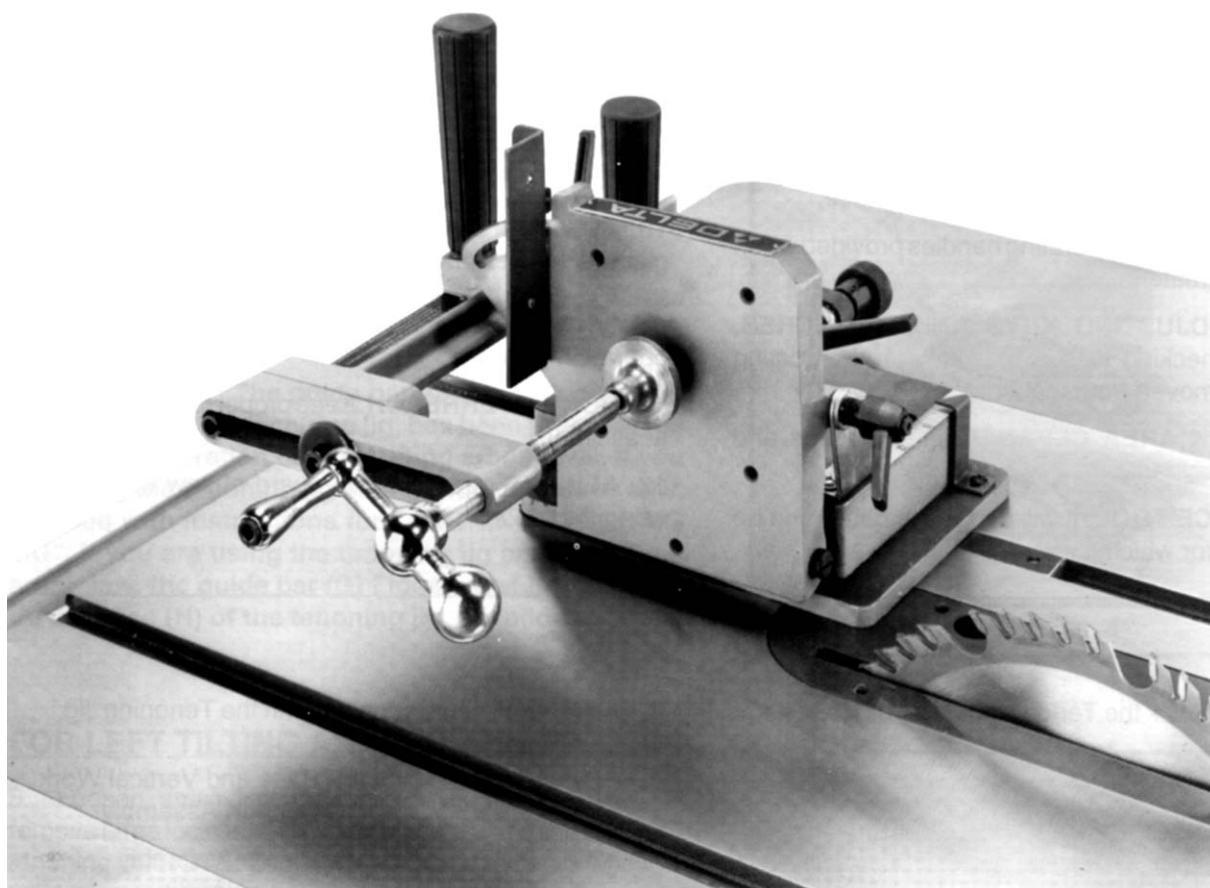

PART NO. 1342471 - 02-02-05
Copyright © 2005 Delta Machinery



To learn more about DELTA MACHINERY
visit our website at: www.deltamachinery.com.

For Parts, Service, Warranty or other Assistance,

please call **1-800-223-7278** (In Canada call **1-800-463-3582**).

TABLE OF CONTENTS

IMPORTANT SAFETY INSTRUCTIONS	2
SAFETY GUIDELINES	3
GENERAL SAFETY RULES	3
ADDITIONAL SPECIFIC SAFETY RULES	4
FUNCTIONAL DESCRIPTION	4
CARTON CONTENTS	4
ASSEMBLY	5
OPERATION	8
TROUBLESHOOTING	14
SERVICE	14
ACCESSORIES	15
WARRANTY	15
SERVICE CENTER LOCATIONSback cover

IMPORTANT SAFETY INSTRUCTIONS

▲ WARNING Read and understand all warnings and operating instructions before using any tool or equipment. When using tools or equipment, basic safety precautions should always be followed to reduce the risk of personal injury. Improper operation, maintenance or modification of tools or equipment could result in serious injury and property damage. There are certain applications for which tools and equipment are designed. Delta Machinery strongly recommends that this product NOT be modified and/or used for any application other than for which it was designed.

If you have any questions relative to its application DO NOT use the product until you have written Delta Machinery and we have advised you.

Online contact form at www.deltamachinery.com

Postal Mail: Technical Service Manager
Delta Machinery
4825 Highway 45 North
Jackson, TN 38305

Information regarding the safe and proper operation of this tool is available from the following sources:

Power Tool Institute
1300 Sumner Avenue, Cleveland, OH 44115-2851
www.powertoolinstitute.org

National Safety Council
1121 Spring Lake Drive, Itasca, IL 60143-3201

American National Standards Institute, 25 West 43rd Street, 4 floor, New York, NY 10036 www.ansi.org
ANSI 01.1 Safety Requirements for Woodworking Machines, and

the U.S. Department of Labor regulations www.osha.gov

SAVE THESE INSTRUCTIONS!

SAFETY GUIDELINES - DEFINITIONS

It is important for you to read and understand this manual. The information it contains relates to protecting YOUR SAFETY and PREVENTING PROBLEMS. The symbols below are used to help you recognize this information.

- ▲ DANGER** Indicates an imminently hazardous situation which, if not avoided, will result in death or serious injury.
- ▲ WARNING** Indicates a potentially hazardous situation which, if not avoided, could result in death or serious injury.
- ▲ CAUTION** Indicates a potentially hazardous situation which, if not avoided, may result in minor or moderate injury.
- CAUTION** Used without the safety alert symbol indicates potentially hazardous situation which, if not avoided, may result in property damage.

GENERAL SAFETY RULES



▲ WARNING READ AND UNDERSTAND ALL WARNINGS AND OPERATING INSTRUCTIONS BEFORE USING THIS EQUIPMENT. Failure to follow all instructions listed below, may result in electric shock, fire, and/or serious personal injury or property damage.

IMPORTANT SAFETY INSTRUCTIONS

1. **FOR YOUR OWN SAFETY, READ INSTRUCTION MANUAL BEFORE OPERATING THE TOOL.** Learn the tool's application and limitations as well as the specific hazards peculiar to it.
2. **KEEP GUARDS IN PLACE** and in working order.
3. **ALWAYS WEAR EYE PROTECTION.** Wear safety glasses. Everyday eyeglasses only have impact resistant lenses; they are not safety glasses. Also use face or dust mask if cutting operation is dusty. These safety glasses must conform to ANSI Z87.1 requirements. **NOTE:** Approved glasses have Z87 printed or stamped on them.
4. **REMOVE ADJUSTING KEYS AND WRENCHES.** Form habit of checking to see that keys and adjusting wrenches are removed from tool before turning it "on".
5. **KEEP WORK AREA CLEAN.** Cluttered areas and benches invite accidents.
6. **DON'T USE IN DANGEROUS ENVIRONMENT.** Don't use power tools in damp or wet locations, or expose them to rain. Keep work area well-lighted.
7. **KEEP CHILDREN AND VISITORS AWAY.** All children and visitors should be kept a safe distance from work area.
8. **MAKE WORKSHOP CHILDPROOF** – with padlocks, master switches, or by removing starter keys.
9. **DON'T FORCE TOOL.** It will do the job better and be safer at the rate for which it was designed.
10. **USE RIGHT TOOL.** Don't force tool or attachment to do a job for which it was not designed.
11. **WEAR PROPER APPAREL.** No loose clothing, gloves, neckties, rings, bracelets, or other jewelry to get caught in moving parts. Nonslip footwear is recommended. Wear protective hair covering to contain long hair.
12. **SECURE WORK.** Use clamps or a vise to hold work when practical. It's safer than using your hand and frees both hands to operate tool.
13. **DON'T OVERREACH.** Keep proper footing and balance at all times.
14. **MAINTAIN TOOLS IN TOP CONDITION.** Keep tools sharp and clean for best and safest performance. Follow instructions for lubricating and changing accessories.
15. **DISCONNECT TOOLS** before servicing and when changing accessories such as blades, bits, cutters, etc.
16. **USE RECOMMENDED ACCESSORIES.** The use of accessories and attachments not recommended by Porter-Cable may cause hazards or risk of injury to persons.
17. **REDUCE THE RISK OF UNINTENTIONAL STARTING.** Make sure switch is in "OFF" position before plugging in power cord. In the event of a power failure, move switch to the "OFF" position.
18. **NEVER STAND ON TOOL.** Serious injury could occur if the tool is tipped or if the cutting tool is accidentally contacted.
19. **CHECK DAMAGED PARTS.** Before further use of the tool, a guard or other part that is damaged should be carefully checked to ensure that it will operate properly and perform its intended function – check for alignment of moving parts, binding of moving parts, breakage of parts, mounting, and any other conditions that may affect its operation. A guard or other part that is damaged should be properly repaired or replaced.
20. **DIRECTION OF FEED.** Feed work into a blade or cutter against the direction of rotation of the blade or cutter only.
21. **NEVER LEAVE TOOL RUNNING UNATTENDED. TURN POWER OFF.** Don't leave tool until it comes to a complete stop.
22. **STAY ALERT, WATCH WHAT YOU ARE DOING, AND USE COMMON SENSE WHEN OPERATING A POWER TOOL. DO NOT USE TOOL WHILE TIRED OR UNDER THE INFLUENCE OF DRUGS, ALCOHOL, OR MEDICATION.** A moment of inattention while operating power tools may result in serious personal injury.
23. **MAKE SURE TOOL IS DISCONNECTED FROM POWER SUPPLY** while motor is being mounted, connected or reconnected.
24. **THE DUST GENERATED** by certain woods and wood products can be injurious to your health. Always operate machinery in well ventilated areas and provide for proper dust removal. Use wood dust collection systems whenever possible.

SAVE THESE INSTRUCTIONS.

Refer to them often and use them to instruct others.

ADDITIONAL SPECIFIC SAFETY RULES

⚠ WARNING FAILURE TO FOLLOW THESE RULES MAY RESULT IN SERIOUS PERSONAL INJURY.

1. **DISCONNECT THE POWER SOURCE** to the machine before attaching or adjusting the jig.
2. **MAKE SURE THAT THE BLADE HAS COME TO A COMPLETE STOP** before adjusting the jig or the workpiece.
3. **KEEP BOTH HANDS** on the operating handles when operating the jig.
4. **REPLACE THE BLADE GUARD OF THE SAW** when the jig operation is complete.
5. **REFER TO THE OWNER'S MANUAL** of the saw for safety rules and other instructions.

FUNCTIONAL DESCRIPTION

FOREWORD

Your new 34-183 Tenoning Jig will help you produce good, strong joints. Although many methods for joining wood exist, the classic mortise-and-tenon joint is one of the strongest and most widely used joints in woodworking. This jig will help you perform this task much easier than ever before.

CARTON CONTENTS

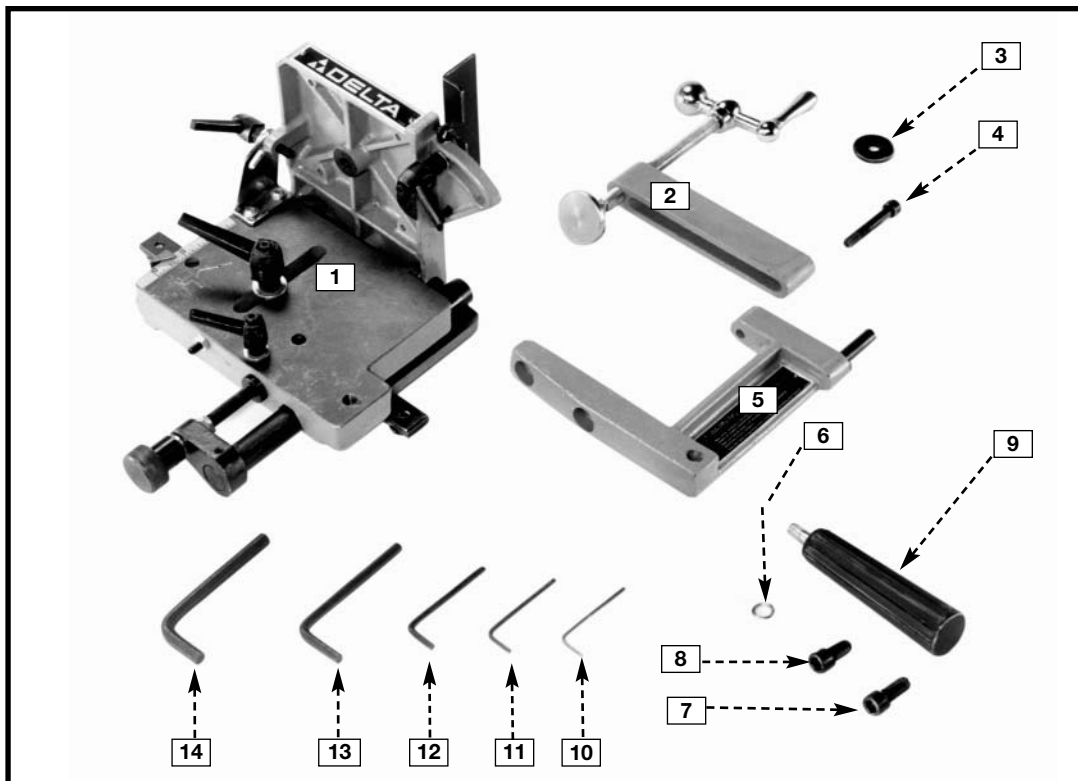

- | | |
|--|---------------------------------|
| 1. Base and Vertical Work Support Assembly | 8. M10 x 20mm Socket Head Screw |
| 2. Clamp Assembly | 9. Handles (2) |
| 3. M8 Flat Washer | 10. 2.5mm Allen Wrench |
| 4. M8 x 50mm Socket Head Screw | 11. 3mm Allen Wrench |
| 5. Clamp Arm | 12. 4mm Allen Wrench |
| 6. M10 Lockwasher (2) | 13. 6mm Allen Wrench |
| 7. M10 x 25mm Socket Head Screw | 14. 8mm Allen Wrench |

UNPACKING AND CLEANING

Carefully unpack the machine and all loose items from the shipping container(s). Remove the protective coating from all unpainted surfaces. This coating may be removed with a soft cloth moistened with kerosene (do not use acetone, gasoline or lacquer thinner for this purpose). After cleaning, cover the unpainted surfaces with a good quality household floor paste wax.

ASSEMBLY

ASSEMBLY TOOLS REQUIRED

2.5mm Hex Wrench (Supplied)
3mm Hex Wrench (Supplied)
8mm Hex Wrench (Supplied)

4mm Hex Wrench (Supplied)
6mm Hex Wrench (Supplied)
Adjustable Wrench

ASSEMBLY TIME ESTIMATE

Assembly time for this unit is approximately 30 minutes.

⚠ WARNING Disconnect the machine from the power source and remove the blade guard before using the tenoning jig. Reinstall the blade guard immediately after jig use is complete. Always unplug the machine before removing or installing the blade guard.

1. Fasten the clamp arm (A) Fig. 3 to the back of the work support plate using the M10 x 25mm socket head screw (B), M10 x 25mm socket head screw (X), and lockwashers.
2. Fasten the clamp assembly (C) Fig. 4 to the clamp arm (A) using the M8 x 50mm socket head screw (D) and flat washer.
3. Fasten the handles (F) Fig. 4 to the clamp arm (A) and base (H).

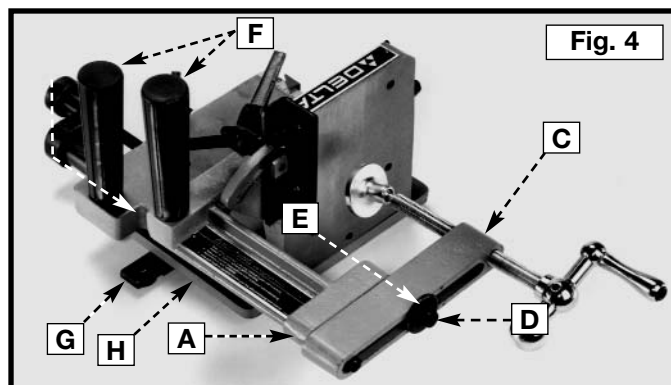
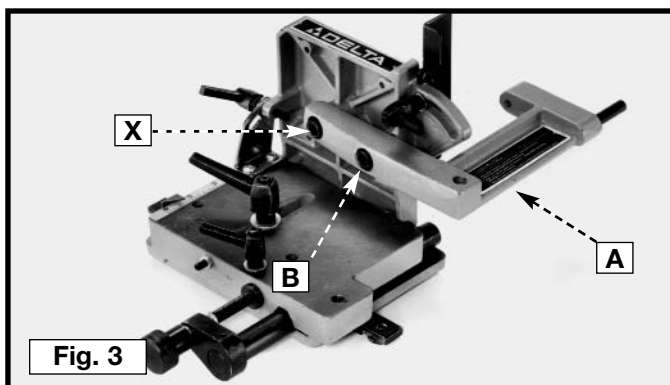

IMPORTANT: The guide bar (G) Fig. 4, located on the base (H) of the tenoning jig, was preset at the factory for operation on right-tilting arbor saws. If your saw is a right-tilt saw, follow the instructions for “**ALIGNING TENONING JIG**”. If your saw is a left-tilt saw, relocate the guide bar (G) Fig. 4 on the base (H) of the tenoning jig by using the following directions.

FOR LEFT-TILTING ARBOR SAWS ONLY

NOTE: Position the tenoning jig in the miter gauge slot to the left of the blade.

4. Loosen the small lock handle (J) Fig. 5. Remove the large lock handle (K) and flat washer (L) Fig. 5 from the tenoning jig.

NOTE: Both lock handles (J) and (K) Fig. 5 are spring-loaded and can be repositioned by pulling out on the handle and repositioning it on the nut located underneath the handle.

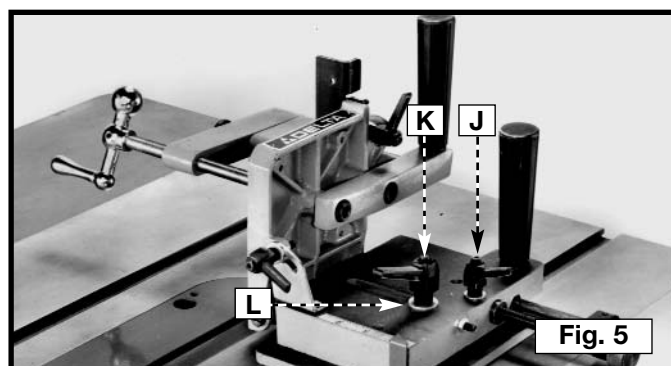

6. Use the supplied 3mm hex wrench to loosen the set screw (M) Fig. 6. Remove the micro-adjustment assembly (N) from the tenoning jig (Fig. 7).

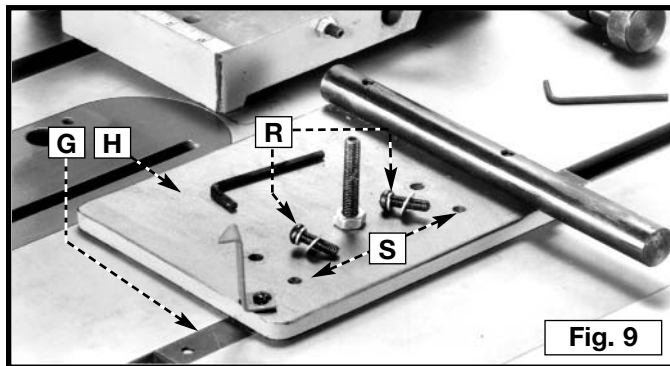
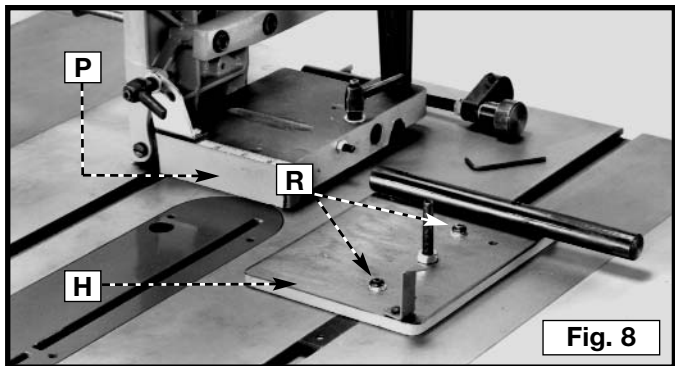
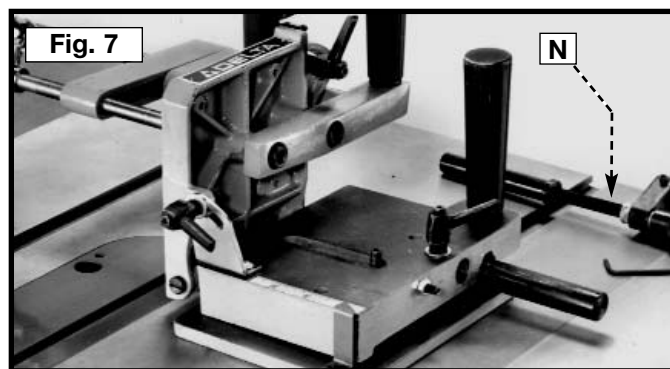
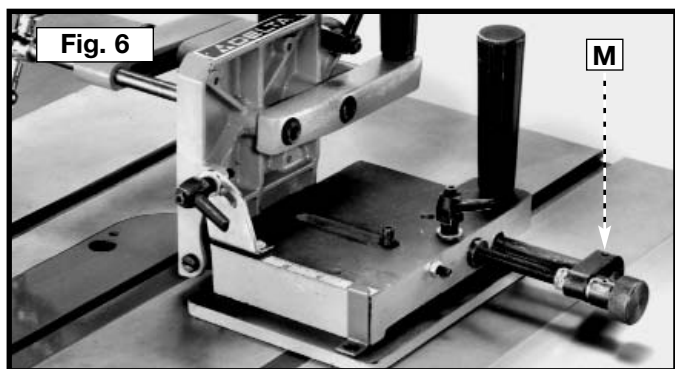

7. Lift the jig assembly (P) Fig. 8 from the base (H). Remove the two button head screws and flat washers (R) from the base.
8. Slide the base (H) Fig. 9 forward until the two holes (S) are aligned with the holes in the guide bar (G). Fasten the base to the guide bar with the two button head screws and flat washers (R) (Fig. 10).
9. Reassemble the items that were removed in **STEPS 4, 5, and 6** in reverse order.

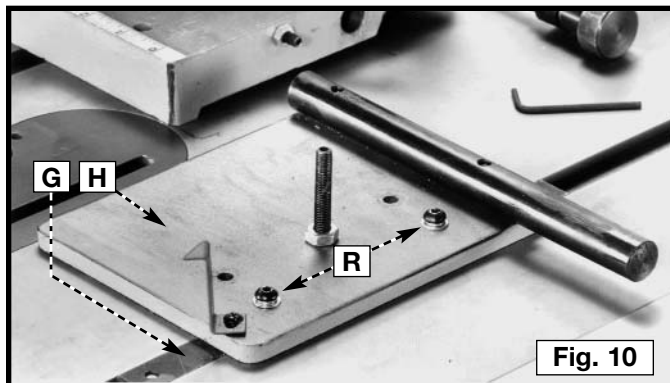

ADJUSTING THE GUIDE BAR TO THE TABLE SLOT

⚠WARNING Disconnect Machine from Power Source

1. The tenoning jig is furnished with an adjustable guide bar (A) Fig. 11 that allows the jig to custom-fit to your saw, eliminating side-to-side play. Also, a T-slot washer (B) is on each end of the guide bar (A) to keep the tenoning jig from lifting during operation.

NOTE: Remove the T-slot washers (B) if your table saw is not equipped with T-slotted miter gauge slots.

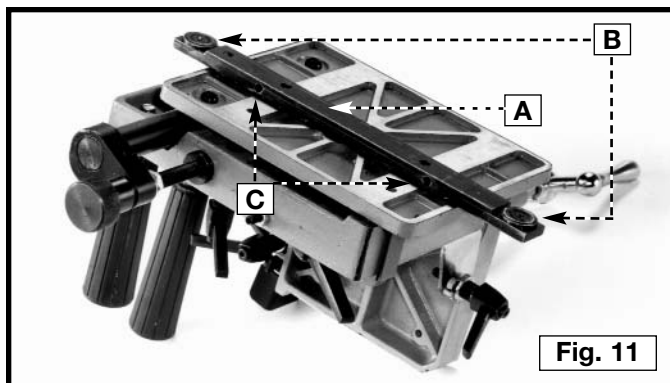

- Place the tenoning jig guide bar (A) Fig. 12 into the left miter slot (D) and slide the tenoning jig back and forth to determine if it has side-to-side play. If the tenoning jig slides easily through the miter slot without side-to-side play, no adjustment is necessary. However, if the tenoning jig fits too snugly, or if there is excessive play between the guide bar (A) and the miter slot (D), adjust the jig, using instructions 3-5 of this section.
- Remove the jig from machine and place it upside down (Fig. 11).
- Use the 2.5mm hex wrench to turn the screws (C) Fig. 11 clockwise for a snug fit, or counter-clockwise for a looser fit.
- Insert the tenoning jig back into the miter slot of the machine to determine if the fit is suitable, or if further adjustment is required.

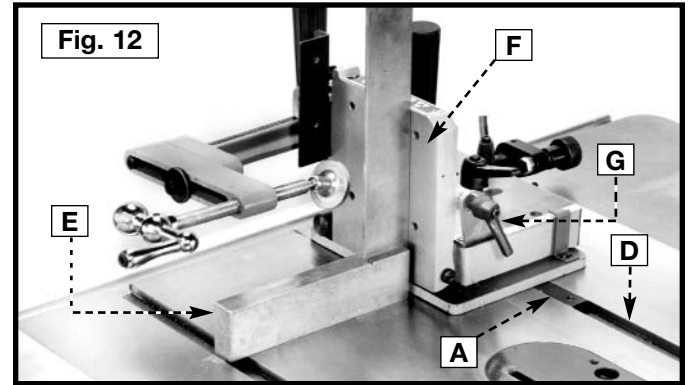

ALIGNING THE TENONING JIG

⚠ WARNING Disconnect Machine from Power Source

- Place the tenoning jig guide bar (A) Fig. 12 into the left miter gauge slot.
- Use a square (E) Fig. 12 to see if the vertical work support plate (F) is 90 degrees to the saw table. If an adjustment is necessary, loosen the lock handle (G) and the set screw (H) Fig. 13, move the vertical work support plate (F) until it is 90 degrees to the table, and tighten the lock handle (G).
- With the vertical work support plate (F) Fig. 13 adjusted, tighten the set screw (H) until it bottoms. This set screw (H) enables you to rapidly position the vertical work support (F) 90 degrees to the table after it has been tilted.
- Use a square (E) Fig. 14 to see if the face of the backstop (J) is 90 degrees to the saw table. If an adjustment is necessary, loosen lock lever (K), adjust backstop (J) accordingly and tighten lever (K).

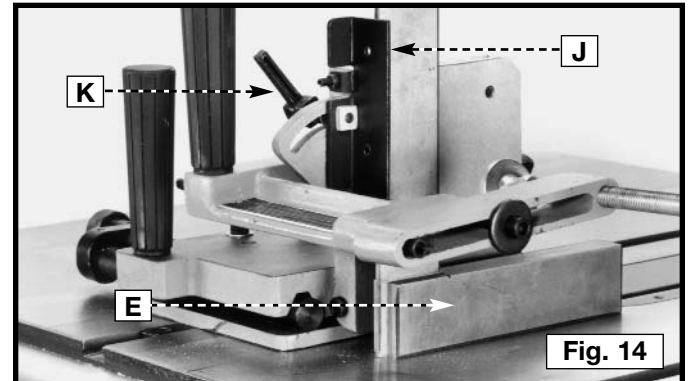
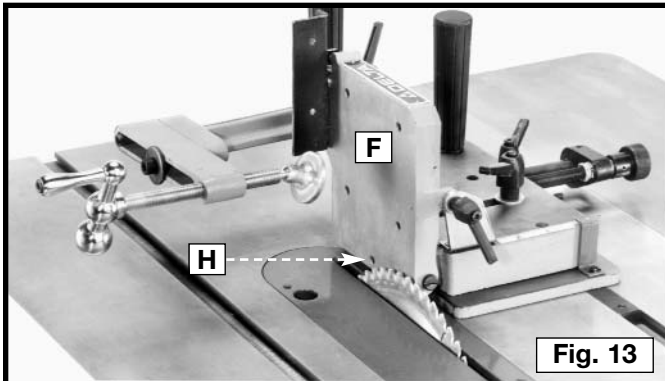

- Loosen the nut (L) Fig. 15, and turn the set screw (M) counter-clockwise, two or three times.
- Loosen the two lock levers (N) and (P) Fig. 16, and move the jig (R) until the vertical work support plate (F) is against the saw blade and tighten the lever (N).

NOTE: The lock levers (N) and (P) are spring-loaded and can be repositioned by pulling up on the handles and repositioning them on the nut located underneath the handles.

- Check to see if the vertical work-support plate (F) Fig. 16 is parallel to the saw blade.
- If an adjustment is necessary, loosen the lever (N) Fig. 16. Rotate the knob (S) clockwise as far as possible to align the holes (T) with the guide bar (X) and to gain access to the set screws. Loosen the two screws inside the holes (T) and move the jig (R) until the vertical work-support plate (F) is parallel to the saw blade. Tighten the two screws inside the holes (T).
- Move the jig (R) Fig. 16 1/8" away from blade so that the vertical work-support plate (F) clears saw blade. Tighten the lever (N).
- Rotate the knob (S) Fig. 16 counter-clockwise until the collar (V) is halfway between the knob (S) and the side of the jig (R); tighten lever (P).

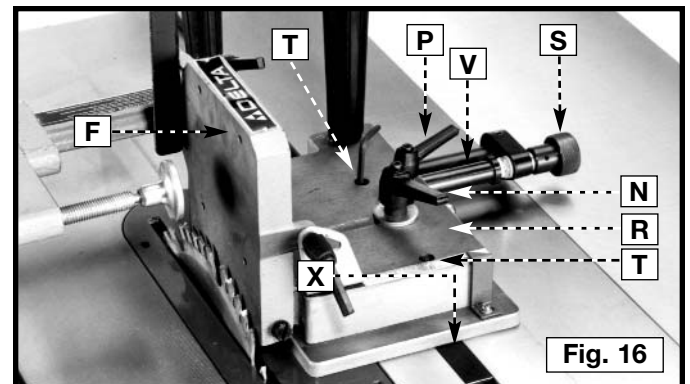
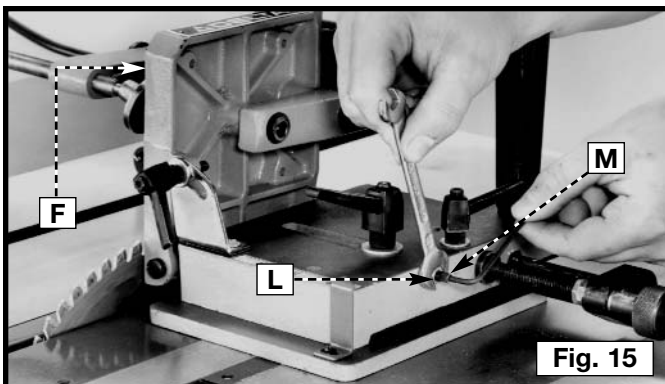

- Turn the screw (M) Fig. 17 clockwise until it bottoms to prevent the vertical work-support plate (F) from accidentally being moved into the blade. Tighten the nut (L).
- Loosen the screw (Y) Fig. 18, and adjust the pointer (Z) to the "1/8" mark on scale.

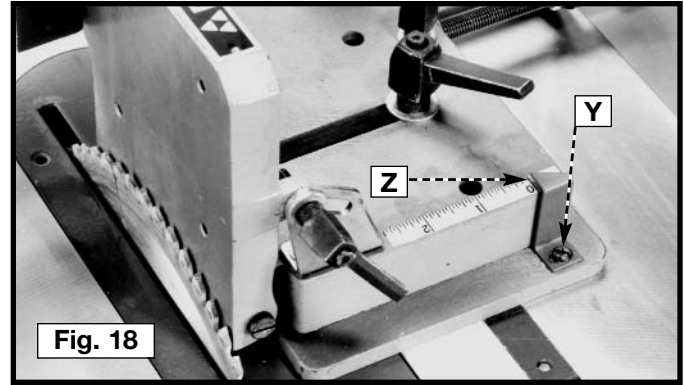
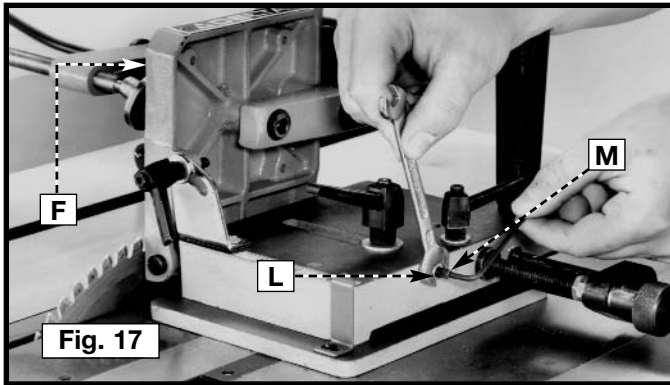

OPERATION

ADJUSTMENTS

⚠ WARNING Disconnect Machine from Power Source

- For rapid adjustment of the work support plate (A) Fig. 19, toward or away from the saw blade, loosen levers (B) and (C) and move jig (D). Tighten levers (B) and (C).
- You can fine-adjust the work support plate (A) Fig. 19, by loosening the lever (B) and rotating the knob (E) until plate (A) is at the desired position. Tighten the lever (B) Fig. 19.
- To tilt the vertical work support plate (A) Fig. 19, loosen the lock lever (F), tilt vertical work support plate to the desired angle, and tighten lock lever (F).
- To adjust backstop (G) Fig. 20, for angle tenons, loosen lock lever (H), tilt backstop (G) to the desired angle and tighten lever (H).

IMPORTANT: The tenoning jig is not equipped with a bevel scale for the positioning of the backstop (G) Fig. 20 or the support plate (A) Fig. 19. Cut the workpiece to the desired angle prior to the jig set up and use it as the angle reference.

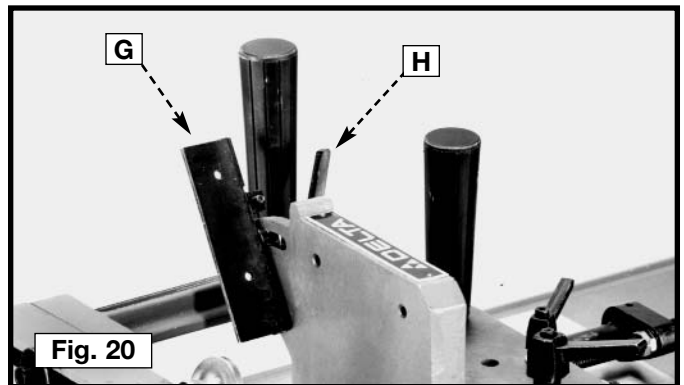
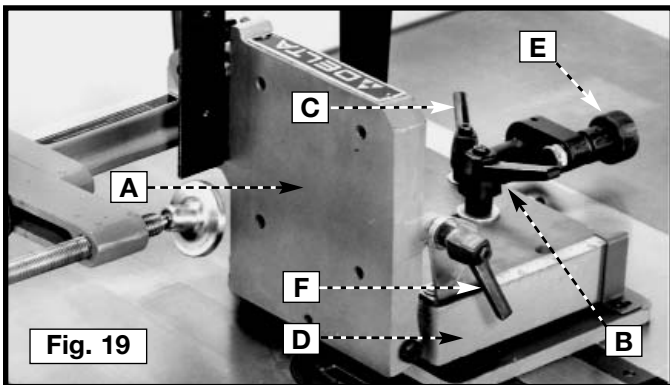

- The tenoning jig features a positive stop to ensure fast and accurate positioning of the backstop (G) Fig. 21 at 90 degrees to the saw table. To check and adjust the positive stop at 90 degrees, loosen lock handle (H) Fig. 21, and place one end of a combination square (J) on the saw table and the other end against backstop (G). If the backstop is not 90 degrees to the table, loosen the locknut (K) Fig. 21, and tighten or loosen the adjustment screw (L) until the head of the screw contacts the casting on the vertical plate (M) at 90 degrees. Tighten the locknut (K) and lock the handle (H).

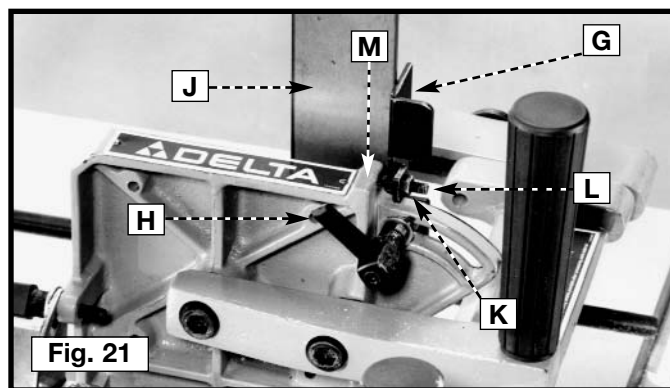

- To eliminate chip-out when performing cheek cuts, you can fasten an auxiliary wooden backup board (P) Fig. 23 to the backstop (G) Fig. 22 with two wood screws through the two pre-drilled holes (N).
- You can also fasten a block of wood to the vertical support plate (R) Fig. 23, through four pre-drilled holes (S) to prevent the saw blade from contacting the jig.

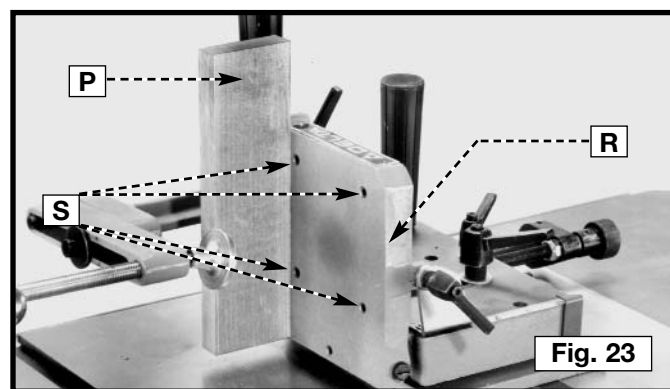
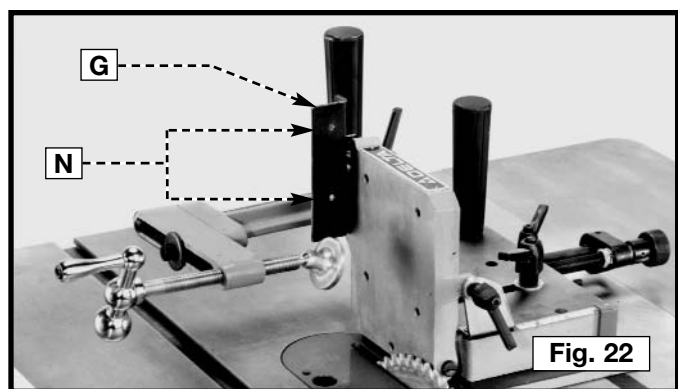

TENONING JIG USE

This jig is intended to perform cheek cuts only. Cheek cuts are made prior to the shoulder cuts, which are made on a table saw using the miter gauge.

⚠ WARNING Keep your hands on the jig handles when performing cuts.

⚠ WARNING Disconnect Machine from Power Source

STRUCTURE OF A MORTISE AND TENON JOINT

Parts of a simple or “blind” joint are (Fig. 24):

- Structural Shoulder
- Cheek
- Cosmetic Shoulder
- Mortise
- Mortise Walls

Lay out the mortise and tenon on the workpieces (Fig. 25), but keep these items in mind when laying out the joints:

- To avoid premature joint failure, avoid locating a tenon in a disfigured part of the grain (a knot), for unpredictable movement of the joint may occur. Use straight, flat, common-grained stock.
- The tenon will shrink in width away from the mortise walls, possibly revealing the mortised hole. When possible, produce tenons with shoulders on all four sides - two structural and two cosmetic - to conceal the mortised hole when wood movement occurs.

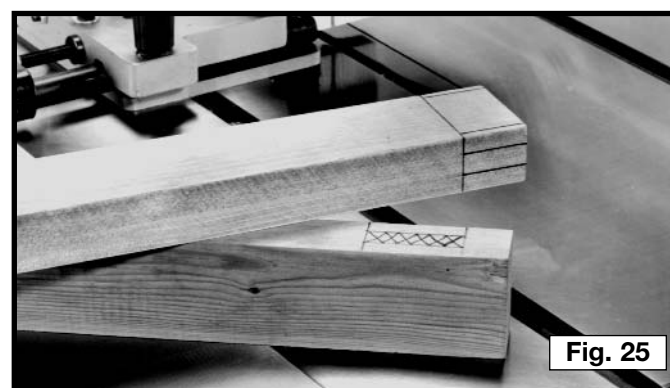
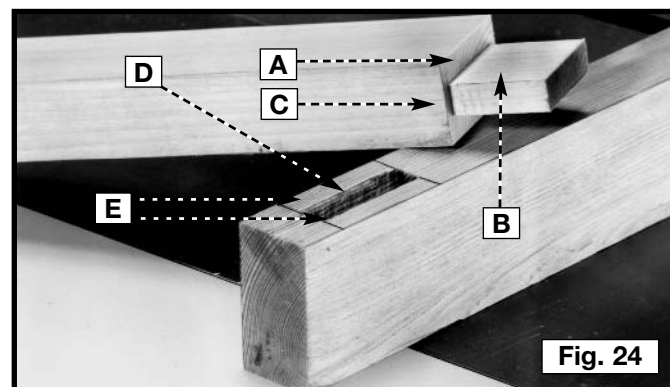

- The objective is to make the parts fit closely together. Maximize the gluing surface by making the tenon as long as possible (approximately 1/2 the width of the stile or longer, if using narrow stock). Balance the joint by using the same amount of wood in the tenon as in the combined thickness of the mortise walls (Fig. 26). If one piece of wood is larger than the other, make the tenon as thick as possible (Fig. 27).
- Remember to figure the kerf of the saw blade when setting up for the cut.
- Cut all mortises first. Make the mortise 1/16" deeper than the length of the tenon to allow for glue.

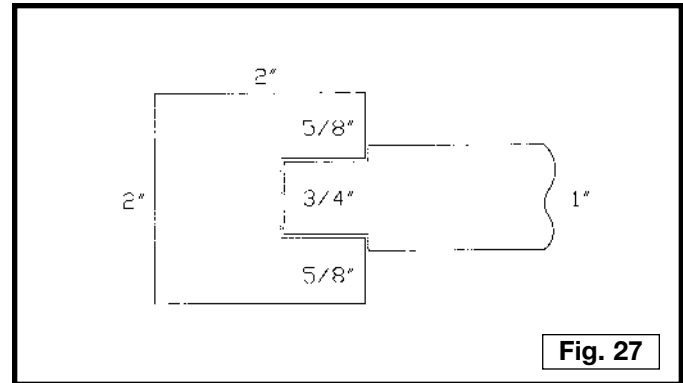
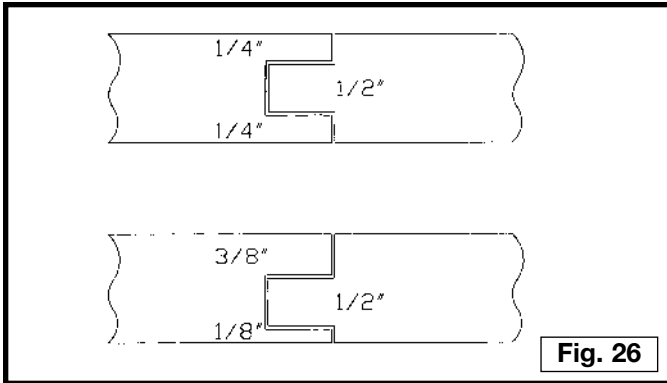

You can use several different methods to cut a mortise and tenon. The following information illustrates one of the easiest and safest methods and utilizes cheek cuts first, then shoulder cuts. Use a base stop (F) Fig. 28 that is the same thickness as the base plate (G) of the tenoning jig (H) and spacer block (K) that is the combined thickness of the tenon and the saw blade, to make the cutting more efficient. This method eliminates possible errors caused by thickness variations in the workpiece, and avoids trapping cut-off pieces between the saw blade and vertical support plate (N).

NOTE: Perform your practice cuts on scrap material before cutting good wood.

⚠ WARNING Use a slow feed rate to help prevent the tenoning jig from lifting during a cut.

1. Clamp a base stop (F) Fig. 28 (the same thickness as the base plate (G) of the tenoning jig (H)) on the front of the saw table. This will allow tenoning jig to pass over the base stop (F).
2. Make a spacer block of wood (K) Fig. 28, equal to the thickness of the tenon plus the thickness of the saw blade.
3. With the tenoning jig (H) Fig. 28 located at the front of saw table and over the base stop (F), load the spacer block (K) and the workpiece (L). Securely clamp both in place with the clamp handle (M). Make certain that both pieces of wood are against the vertical support plate (N) and the backup board (P).
4. Gently push the tenoning jig (H) Fig. 28 toward the saw blade until workpiece is near the saw blade. Adjust the tenoning jig (H) and the saw blade to make the first cheek cut. Return the tenoning jig (H) to the front of saw table.
5. Connect the saw to the power source.

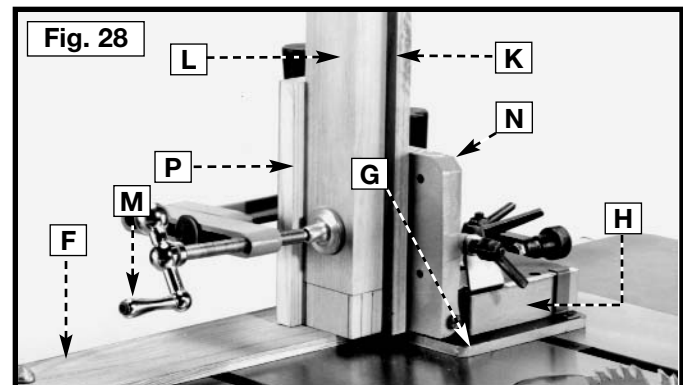

⚠ WARNING Keep your hands on the jig handles when performing cuts.

6. Turn the saw "ON" and perform the first structural cheek cut (Fig. 29). Feed the tenoning jig toward the saw blade at a slow feed rate until the saw blade has exited the back of the workpiece. Turn the tool off and allow the blade to come to a complete stop, then slowly pull the tenoning jig back to the position shown in Fig. 28.

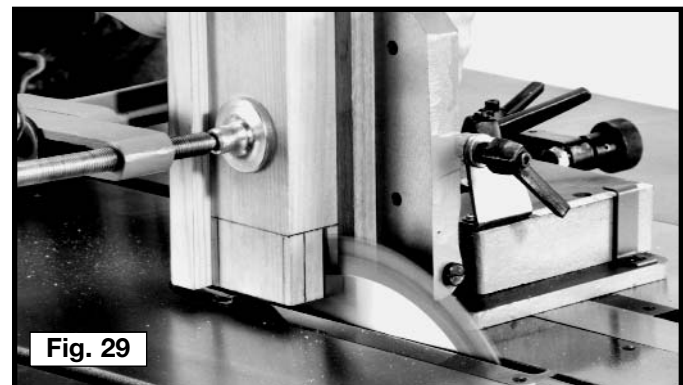

- Loosen the clamp (M) Fig. 28. Remove the spacer block (K) Fig. 28. Remove the spacer block (K) and secure the workpiece (L) Fig. 29 in place. Keep the same face of the workpiece (L) against the vertical support plate (N) and the backup board (P). Turn the machine “on”, perform the second structural cheek cut, and turn the machine “off”. Allow the blade to come to a complete stop, then slowly pull the tenoning jig back to the position shown in Fig. 28.

⚠ WARNING Disconnect Machine from Power Source

- Load and secure the workpiece (L) Fig. 31 on the tenoning jig and adjust the jig to perform the third and fourth cosmetic cheek cuts. Connect the machine to the power source, turn the saw “on”, and make the cuts.

NOTE: When cutting the cosmetic cheek cuts, do not use the spacer block (K) Fig. 28. You can turn the workpiece 180 degrees. The discrepancies in the workpiece are not as critical when cutting the cosmetic cheeks as compared to the structural cheeks.

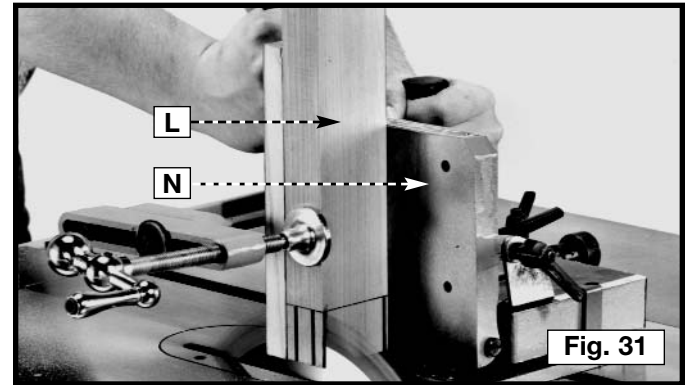
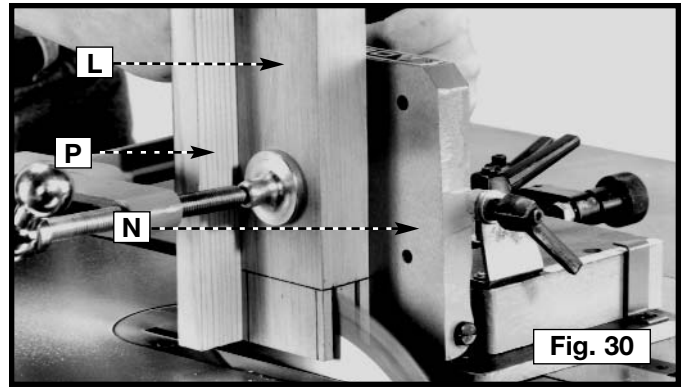

CUTTING THE SHOULDERS OF THE TENON

⚠ WARNING Disconnect Machine from Power Source

⚠ WARNING To avoid personal injury or damage to the machine, always use a cross-cut blade to perform the shoulder cuts of the tenon.

CAUTION When performing the shoulder cuts of the tenon, do not cut into the cheeks of the tenon. It will greatly reduce the strength of the joint.

NOTE: Perform your practice cuts on scrap material before cutting good wood.

- Remove the tenoning jig from the machine.
- Lay the workpiece (L) Fig. 32 on the saw table and adjust the saw blade (R) to cut the structural shoulders of the tenon.
- Clamp a wooden stop block (S) Fig. 33 to the front of the saw fence (T), and adjust the saw fence to cut the structural shoulders of the tenon.

NOTE: Remember to figure in the width of the saw blade.

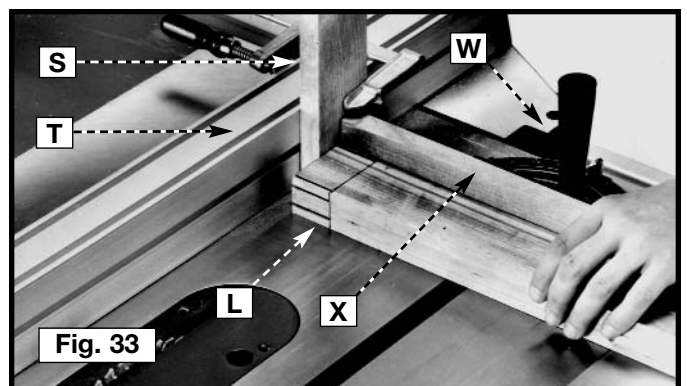
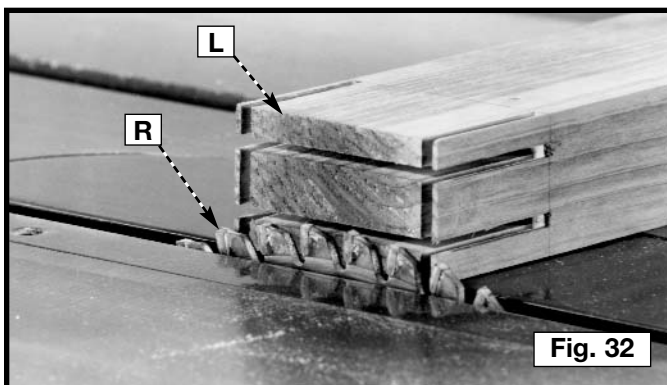

⚠WARNING

Position the wooden stop block (S) Fig. 34 in front of the saw blade to prevent the workpiece from being trapped between the saw fence and the saw, causing kickback. Make sure that the workpiece is clear of the wooden stop block (S) before contacting the saw blade.

4. Use a miter gauge (W) Fig. 34, equipped with a backup board (X), to position the workpiece (L) so that you can cut the structural shoulders. Make certain that the workpiece (L) is against the wooden stop block (S) and the backup board (X).
5. Connect the machine to the power source.
6. Turn the machine "ON" and perform the structural shoulder cut by slowly pushing the miter gauge (W) Fig. 34 toward the saw blade until the saw blade is completely through the workpiece. Turn the machine "OFF". **Wait for the blade to come to a complete stop** and remove the cut-off piece.
7. Return the miter gauge (W) Fig. 34 to the position shown, and perform the other structural shoulder cut in the same manner.
8. Fig. 35 illustrates workpiece (L) with the two structural shoulders (M) cut.
9. Adjust the blade height to perform the cosmetic shoulder cuts.
10. Connect the saw to power source.
11. Perform the cosmetic shoulder cuts in the same manner as the structural shoulder cuts.

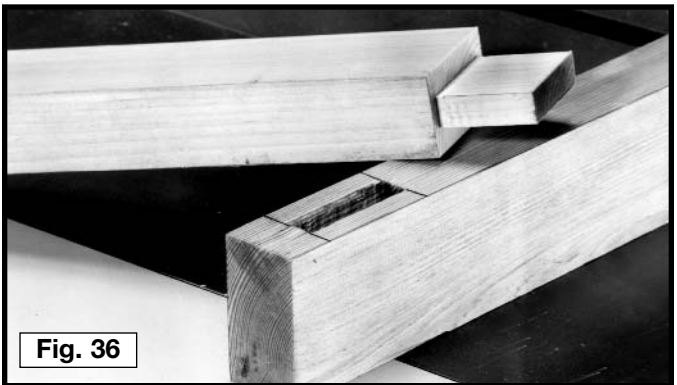
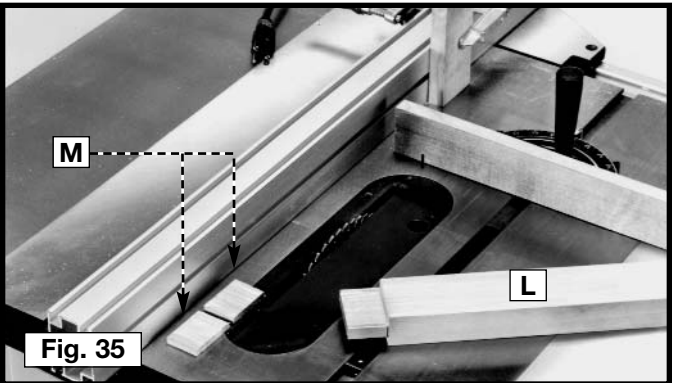
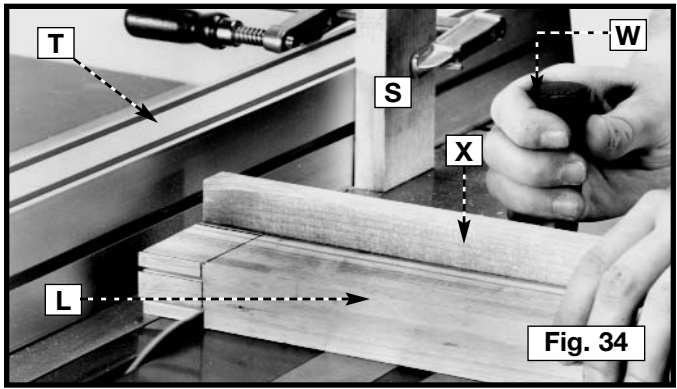

⚠WARNING

Disconnect Machine from Power Source

CAUTION

When performing the shoulder cuts of the tenon, do not cut into the cheeks of the tenon. It will greatly reduce the strength of the joint.

12. Fig. 36 illustrates a simple, or "blind" mortise-and-tenon joint.

EXAMPLES OF MORTISE-AND-TENON JOINTS

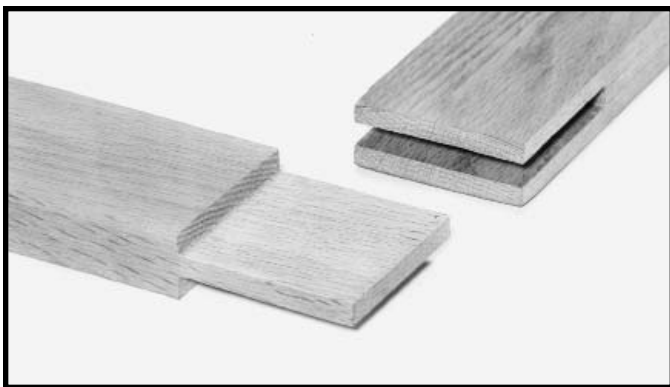

OPEN MORTISE AND TENON JOINT

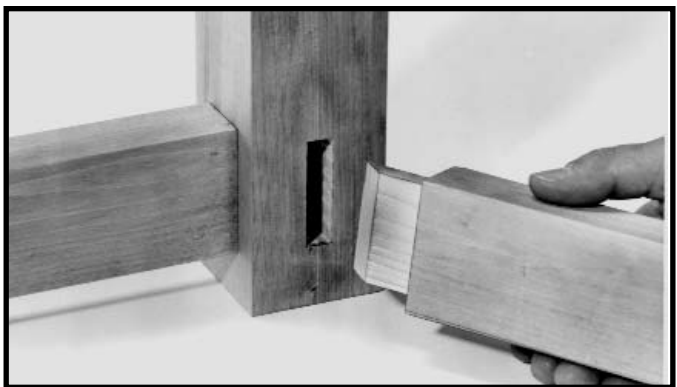

MITERED MORTISE AND TENON JOINT

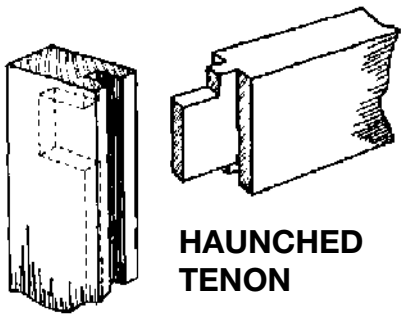

HAUNCHED TENON

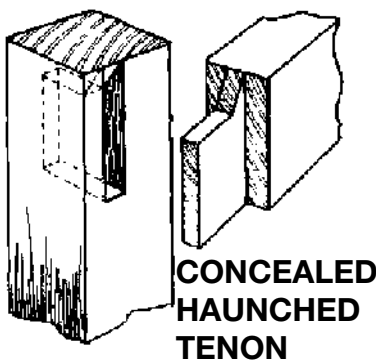

CONCEALED HAUNCHED TENON

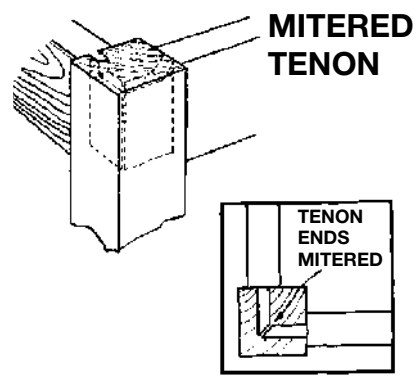

MITERED TENON

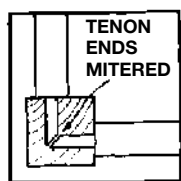

TENON ENDS MITERED

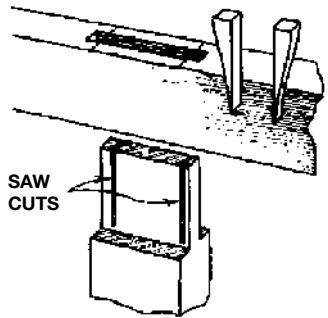

SAW CUTS

THROUGH-WEDGED TENON

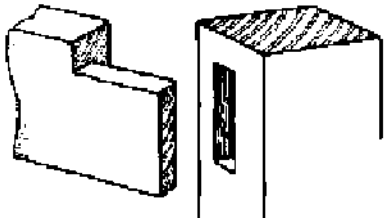

BARE FACED TENON

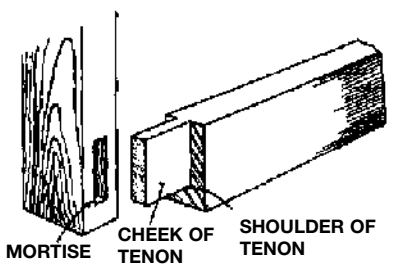

MORTISE CHEEK OF TENON SHOULDER OF TENON

SIMPLE MORTISE AND TENON

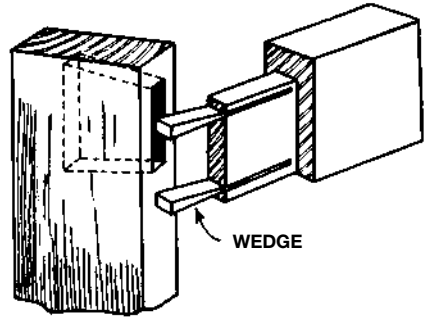

WEDGE

BLIND-WEDGED TENON

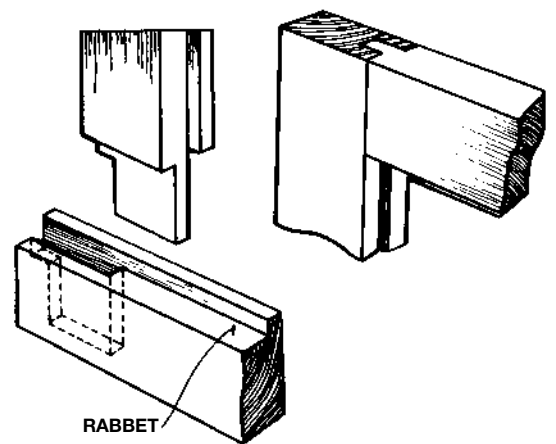

RABBET

TENON WITH LONG AND SHORT SHOULDERS

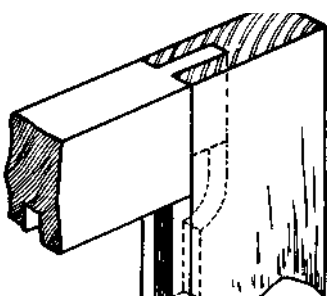

STUB TENON

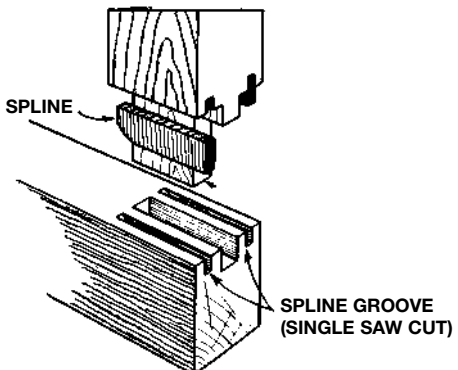

SPLINE

SPLINE GROOVE (SINGLE SAW CUT)

MORTISE AND TENON WITH SPLINES

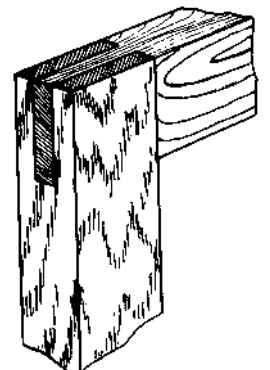

OPEN MORTISE TENON

TROUBLESHOOTING GUIDE

For assistance with your tool, visit our website at www.deltamachinery.com for a list of service centers or call the DELTA Machinery help line at 1-800-223-7278 (In Canada call 1-800-463-3582).

SERVICE



PARTS, SERVICE OR WARRANTY ASSISTANCE

All Delta Machines and accessories are manufactured to high quality standards and are serviced by a network of Porter-Cable • Delta Factory Service Centers and Delta Authorized Service Stations. To obtain additional information regarding your Delta quality product or to obtain parts, service, warranty assistance, or the location of the nearest service outlet, please call 1-800-223-7278 (In Canada call 1-800-463-3582).

ACCESSORIES

A complete line of accessories is available from your Delta Supplier, Porter-Cable • Delta Factory Service Centers, and Delta Authorized Service Stations. Please visit our Web Site www.deltamachinery.com for a catalog or for the name of your nearest supplier.

▲ WARNING Since accessories other than those offered by Delta have not been tested with this product, use of such accessories could be hazardous. For safest operation, only Delta recommended accessories should be used with this product.



Two Year Limited New Product Warranty

Delta will repair or replace, at its expense and at its option, any new Delta machine, machine part, or machine accessory which in normal use has proven to be defective in workmanship or material, provided that the customer returns the product prepaid to a Delta factory service center or authorized service station with proof of purchase of the product within two years and provides Delta with reasonable opportunity to verify the alleged defect by inspection. For all refurbished Delta product, the warranty period is 180 days. Delta may require that electric motors be returned prepaid to a motor manufacturer's authorized station for inspection and repair or replacement. Delta will not be responsible for any asserted defect which has resulted from normal wear, misuse, abuse or repair or alteration made or specifically authorized by anyone other than an authorized Delta service facility or representative. Under no circumstances will Delta be liable for incidental or consequential damages resulting from defective products. This warranty is Delta's sole warranty and sets forth the customer's exclusive remedy, with respect to defective products; all other warranties, express or implied, whether of merchantability, fitness for purpose, or otherwise, are expressly disclaimed by Delta.

PORTER-CABLE • DELTA SERVICE CENTERS (CENTROS DE SERVICIO DE PORTER-CABLE • DELTA)

Parts and Repair Service for Porter-Cable • Delta Machinery are Available at These Locations
(Obtenga Refaccion de Partes o Servicio para su Herramienta en los Sigüientes Centros de Porter-Cable • Delta)

ARIZONA

Tempe 85282 (Phoenix)
2400 West Southern Avenue
Suite 105
Phone: (602) 437-1200
Fax: (602) 437-2200

CALIFORNIA

Ontario 91761 (Los Angeles)
3949A East Guasti Road
Phone: (909) 390-5555
Fax: (909) 390-5554

San Diego 92111
7638 Clairemnot Blvd.
Phone: (858) 277-9595
Fax: (858) 277-9696

San Leandro 94577 (Oakland)
3039 Teagarden Street
Phone: (510) 357-9762
Fax: (510) 357-7939

COLORADO

Arvada 80003 (Denver)
8175 Sheridan Blvd., Unit S
Phone: (303) 487-1809
Fax: (303) 487-1868

FLORIDA

Davie 33314 (Miami)
4343 South State Rd. 7 (441)
Unit #107
Phone: (954) 321-6635
Fax: (954) 321-6638

Tampa 33609
4538 W. Kennedy Boulevard
Phone: (813) 877-9585
Fax: (813) 289-7948

GEORGIA

Forest Park 30297 (Atlanta)
5442 Frontage Road,
Suite 112
Phone: (404) 608-0006
Fax: (404) 608-1123

ILLINOIS

Addison 60101 (Chicago)
400 South Rohlwing Rd.
Phone: (630) 424-8805
Fax: (630) 424-8895

Woodridge 60517 (Chicago)
2033 West 75th Street
Phone: (630) 910-9200
Fax: (630) 910-0360

MARYLAND

Elkridge 21075 (Baltimore)
7397-102 Washington Blvd.
Phone: (410) 799-9394
Fax: (410) 799-9398

MASSACHUSETTS

Franklin 02038 (Boston)
Franklin Industrial Park
101E Constitution Blvd.
Phone: (508) 520-8802
Fax: (508) 528-8089

MICHIGAN

Madison Heights 48071 (Detroit)
30475 Stephenson Highway
Phone: (248) 597-5000
Fax: (248) 597-5004

MINNESOTA

Minneapolis 55429
5522 Lakeland Avenue North
Phone: (763) 561-9080
Fax: (763) 561-0653

MISSOURI

North Kansas City 64116
1141 Swift Avenue
Phone: (816) 221-2070
Fax: (816) 221-2897

St. Louis 63119
7574 Watson Road
Phone: (314) 968-8950
Fax: (314) 968-2790

NEW YORK

Flushing 11365-1595 (N.Y.C.)
175-25 Horace Harding Expwy.
Phone: (718) 225-2040
Fax: (718) 423-9619

NORTH CAROLINA

Charlotte 28270
9129 Monroe Road, Suite 115
Phone: (704) 841-1176
Fax: (704) 708-4625

OHIO

Columbus 43214
4560 Indianola Avenue
Phone: (614) 263-0929
Fax: (614) 263-1238

Cleveland 44125
8001 Sweet Valley Drive
Unit #19
Phone: (216) 447-9030
Fax: (216) 447-3097

OREGON

Portland 97230
4916 NE 122 nd Ave.
Phone: (503) 252-0107
Fax: (503) 252-2123

PENNSYLVANIA

Willow Grove 19090
(Philadelphia)
520 North York Road
Phone: (215) 658-1430
Fax: (215) 658-1433

TEXAS

Carrollton 75006 (Dallas)
1300 Interstate 35 N, Suite 112
Phone: (972) 446-2996
Fax: (972) 446-8157

Houston 77043
4321 Sam Houston Parkway,
West
Suite 180
Phone: (713) 983-9910
Fax: (713) 983-6645

WASHINGTON

Auburn 98001 (Seattle)
3320 West Valley HWY, North
Building D, Suite 111
Phone: (253) 333-8353
Fax: (253) 333-9613

Authorized Service Stations are located in many large cities. Telephone **800-438-2486** or **731-541-6042** for assistance locating one. Parts and accessories for Porter-Cable•Delta products should be obtained by contacting any Porter-Cable•Delta Distributor, Authorized Service Center, or Porter-Cable•Delta Factory Service Center. If you do not have access to any of these, call **800-223-7278** and you will be directed to the nearest Porter-Cable•Delta Factory Service Center. Las Estaciones de Servicio Autorizadas están ubicadas en muchas grandes ciudades. Llame al **800-438-2486** ó al **731-541-6042** para obtener asistencia a fin de localizar una. Las piezas y los accesorios para los productos Porter-Cable•Delta deben obtenerse poniéndose en contacto con cualquier distribuidor Porter-Cable•Delta, Centro de Servicio Autorizado o Centro de Servicio de Fábrica Porter-Cable•Delta. Si no tiene acceso a ninguna de estas opciones, llame al **800-223-7278** y le dirigirán al Centro de Servicio de Fábrica Porter-Cable•Delta más cercano.

CANADIAN PORTER-CABLE • DELTA SERVICE CENTERS

ALBERTA

Bay 6, 2520-23rd St. N.E.
Calgary, Alberta
T2E 8L2
Phone: (403) 735-6166
Fax: (403) 735-6144

BRITISH COLUMBIA

8520 Baxter Place
Burnaby, B.C.
V5A 4T8
Phone: (604) 420-0102
Fax: (604) 420-3522

MANITOBA

1699 Dublin Avenue
Winnipeg, Manitoba
R3H 0H2
Phone: (204) 633-9259
Fax: (204) 632-1976

ONTARIO

505 Southgate Drive
Guelph, Ontario
N1H 6M7
Phone: (519) 767-4132
Fax: (519) 767-4131

QUÉBEC

1515 ave.
St-Jean Baptiste, Suite 160
Québec, Québec
G2E 5E2
Phone: (418) 877-7112
Fax: (418) 877-7123

1447, Begin
St-Laurent, (Montréal),
Québec
H4R 1V8
Phone: (514) 336-8772
Fax: (514) 336-3505

The following are trademarks of PORTER-CABLE • DELTA (Las siguientes son marcas registradas de PORTER-CABLE • DELTA S.A.) (Les marques suivantes sont des marques de fabriquant de la PORTER-CABLE • DELTA): Auto-Set®, BAMMER®, B.O.S.S.®, Builder's Saw®, Contractor's Saw®, Contractor's Saw II™, Delta®, DELTACRAFT®, DELTAGRAM™, Delta Series 2000™, DURATRONIC™, Emc2™, FLEX®, Flying Chips™, FRAME SAW®, Grip Vac™, Homecraft®, INNOVATION THAT WORKS®, Jet-Lock®, JETSTREAM®, 'kickstand®, LASERLOC®, MICRO-SET®, Micro-Set®, MIDI LATHE®, MORTEN™, NETWORK™, OMNIJIG®, POCKET CUTTER®, PORTA-BAND®, PORTA-PLANE®, PORTER-CABLE®&(design), PORTER-CABLE®PROFESSIONAL POWER TOOLS, PORTER-CABLE REDEFINING PERFORMANCE™, Posi-Matic®, Q-3®&(design), QUICKSAND®&(design), QUICKSET™, QUICKSET II®, QUICKSET PLUS™, RIPTIDE™&(design), SAFE GUARD II®, SAFE-LOC®, Sanding Center®, SANDTRAP®&(design), SAW BOSS®, Sawbuck™, Sidekick®, SPEED-BLOC®, SPEEDMATIC®, SPEEDTRONIC®, STAIR EASE®, The American Woodshop®&(design), The Lumber Company®&(design), THE PROFESSIONAL EDGE®, THE PROFESSIONAL SELECT®, THIN-LINE™, TIGER®, TIGER CUB®, TIGER SAW®, TORQBUSTER®, TORQ-BUSTER®, TRU-MATCH™, TWIN-LITE®, UNIGUARD®, Unifence®, UNIFEEDER™, Unihead®, Uniplane™, Unirip®, Unisaw®, Univise®, Versa-Feeder®, VERSA-PLANE®, WHISPER SERIES®, WOODWORKER'S CHOICE™.

Trademarks noted with ™ and ® are registered in the United States Patent and Trademark Office and may also be registered in other countries. Las Marcas Registradas con el signo de ™ y ® son registradas por la Oficina de Registros y Patentes de los Estados Unidos y también pueden estar registradas en otros países.