

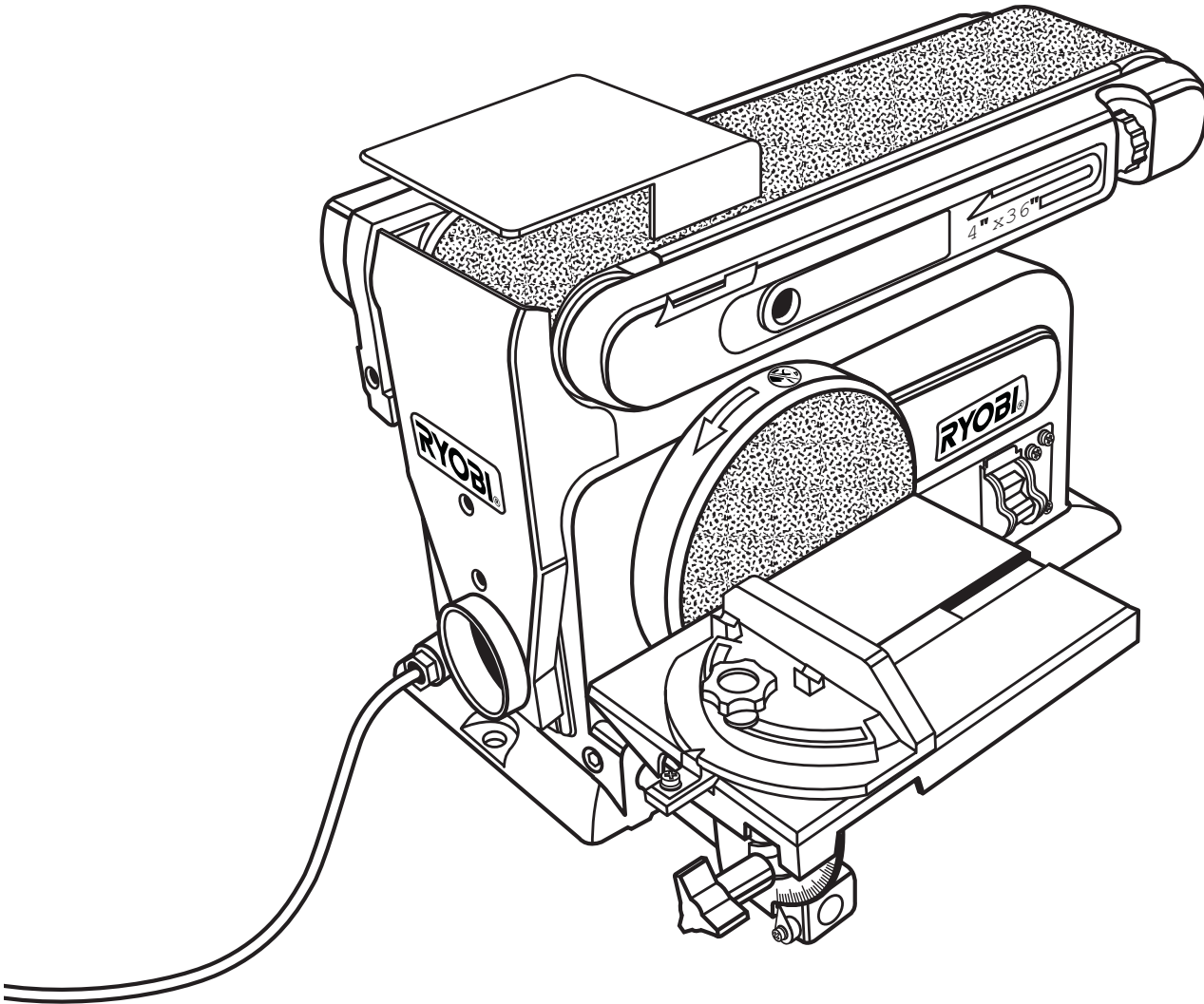

OPERATOR'S MANUAL

BELT/DISC SANDER

BD4600



Your belt/disc sander has been engineered and manufactured to our high standard for dependability, ease of operation, and operator safety. When properly cared for, it will give you years of rugged, trouble-free performance.

WARNING: To reduce the risk of injury, the user must read and understand the operator's manual before using this product.

Thank you for your purchase.

SAVE THIS MANUAL FOR FUTURE REFERENCE

TABLE OF CONTENTS

■ Introduction	2
■ Warranty	2
■ General Safety Rules	3-4
■ Specific Safety Rules.....	4
■ Symbols.....	5-6
■ Electrical	7
■ Glossary of Terms.....	8
■ Features.....	9-10
■ Loose Parts	11
■ Assembly	11-13
■ Operation.....	14-15
■ Adjustments.....	16
■ Maintenance.....	17
■ Parts Ordering / Service	Back Page

INTRODUCTION

This tool has many features for making its use more pleasant and enjoyable. Safety, performance, and dependability have been given top priority in the design of this product making it easy to maintain and operate.

WARRANTY

RYOBI® POWER TOOL - LIMITED TWO YEAR WARRANTY AND 30 DAY EXCHANGE POLICY

One World Technologies, Inc., warrants its RYOBI® power tools with the following conditions:

30-DAY EXCHANGE POLICY: During the first 30 days after date of purchase, you may either request service under this warranty or you may exchange any RYOBI® power tool which does not work properly due to defective workmanship or materials by returning the power tool to the dealer from which it was purchased. To receive a replacement power tool or requested warranty service, you must present proof of purchase and return all original equipment packaged with the original product. The replacement power tool will be covered by the limited warranty for the balance of the two year period from the date of the original purchase.

WHAT THIS WARRANTY COVERS: This warranty covers all defects in workmanship or materials in your RYOBI® power tool for a period of two years from the date of purchase. With the exception of batteries, power tool accessories are warranted for ninety (90) days. Batteries are warranted for two years.

HOW TO GET SERVICE: Just return the power tool, properly packaged and postage prepaid, to an Authorized Service Center. You can obtain the location of the Service Center nearest you by contacting a service representative at One World Technologies, Inc., P.O. Box 1207, Anderson, SC 29622-1207, by calling 1-800-525-2579 or by logging on to www.ryobitools.com. When you request warranty service, you must also present proof of purchase documentation, which includes the date of purchase (for example, a bill of sale). We will repair any faulty workmanship, and either repair or replace any defective part, at our option. We will do so without any charge to you. We will complete the work in a reasonable time, but, in any case, within ninety (90) days or less.

WHAT'S NOT COVERED: This warranty applies only to the original purchaser at retail and may not be transferred. This warranty only covers defects arising under normal usage and does not cover any malfunction, failure or defects resulting from misuse, abuse, neglect, alteration, modification or repairs by other than Authorized Service Centers. One World Technologies, Inc. makes no warranties, representations or promises as to the quality or performance of its power tools other than those specifically stated in this warranty.

ADDITIONAL LIMITATIONS: Any implied warranties granted under state law, including warranties of merchantability or fitness for a particular purpose, are limited to two years from the date of purchase. One World Technologies, Inc. is not responsible for direct, indirect, or incidental damages, so the above limitations and exclusions may not apply to you. This warranty gives you specific legal rights, and you may also have other rights which vary from state to state.

GENERAL SAFETY RULES



WARNING:

Read and understand all instructions. Failure to follow all instructions listed below, may result in electric shock, fire and/or serious personal injury.

READ ALL INSTRUCTIONS

WORK AREA

- **KNOW YOUR POWER TOOL.** Read the operator's manual carefully. Learn the applications and limitations as well as specific potential hazards related to this tool.
- **GUARD AGAINST ELECTRICAL SHOCK BY PREVENTING BODY CONTACT WITH GROUNDED SURFACES.** For example: pipes, radiators, ranges, refrigerator enclosures.
- **KEEP GUARDS IN PLACE** and in working order.
- **REMOVE ADJUSTING KEYS AND WRENCHES.** Form habit of checking to see keys and adjusting wrenches are removed from tool before turning it on.
- **KEEP THE WORK AREA CLEAN.** Cluttered work areas and work benches invite accidents. **DO NOT** leave tools or pieces of wood on the tool while it is in operation.
- **DO NOT USE IN DANGEROUS ENVIRONMENTS.** Do not use power tools in damp or wet locations or expose them to rain. Keep the work area well lit.
- **KEEP CHILDREN AND VISITORS AWAY.** All visitors should wear safety glasses and be kept a safe distance from work area. Do not let visitors contact tool or extension cord while operating.
- **MAKE WORKSHOP CHILDPROOF** with padlocks, master switches, or by removing starter keys.
- **DON'T FORCE THE TOOL.** It will do the job better and safer at the rate for which it was designed.
- **USE THE RIGHT TOOL.** Do not force the tool or attachment to do a job for which it was not designed.
- **USE THE PROPER EXTENSION CORD.** Make sure your extension cord is in good condition. Use only a cord heavy enough to carry the current your product will draw. An undersized cord will cause a drop in line voltage resulting in loss of power and overheating. A wire gauge size (A.W.G.) of at least **16** is recommended for an extension cord 50 feet or less in length. If in doubt, use the next heavier gauge. The smaller the gauge number, the heavier the cord.
- **DRESS PROPERLY.** Do not wear loose clothing, neckties, or jewelry that can get caught and draw you into moving parts. Rubber gloves and nonslip footwear are recommended when working outdoors. Also wear protective hair covering to contain long hair.
- **ALWAYS WEAR SAFETY GLASSES WITH SIDE SHIELDS.** Everyday eyeglasses have only impact-resistant lenses, they are **NOT** safety glasses.
- **SECURE WORK.** Use clamps or a vise to hold work when practical, it is safer than using your hand and frees both hands to operate the tool.
- **DO NOT OVERREACH.** Keep proper footing and balance at all times.

- **MAINTAIN TOOLS WITH CARE.** Keep tools sharp and clean for best and safest performance. Follow instructions for lubricating and changing accessories.
- **DISCONNECT TOOLS.** When not in use, before servicing, or when changing attachments, blades, bits, cutters, etc., all tools should be disconnected from power source.
- **AVOID ACCIDENTAL STARTING.** Be sure switch is off when plugging in any tool.
- **USE RECOMMENDED ACCESSORIES.** Consult the operator's manual for recommended accessories. The use of improper accessories may result in injury.
- **NEVER STAND ON TOOL.** Serious injury could occur if the tool is tipped.
- **CHECK DAMAGED PARTS.** Before further use of the tool, a guard or other part that is damaged should be carefully checked to determine that it will operate properly and perform its intended function. Check for alignment of moving parts, binding of moving parts, breakage of parts, mounting and any other conditions that may affect its operation. A guard or other part that is damaged must be properly repaired or replaced by an authorized service center to avoid risk of personal injury.
- **USE THE RIGHT DIRECTION OF FEED.** Feed work into a blade, cutter, or sanding spindle against the direction or rotation of the blade, cutter, or sanding spindle only.
- **NEVER LEAVE TOOL RUNNING UNATTENDED. TURN THE POWER OFF.** Don't leave tool until it comes to a complete stop.
- **PROTECT YOUR LUNGS.** Wear a face or dust mask if the cutting operation is dusty.
- **PROTECT YOUR HEARING.** Wear hearing protection during extended periods of operation.
- **DO NOT ABUSE CORD.** Never carry tool by the cord or yank it to disconnect from receptacle. Keep cord from heat, oil, and sharp edges.
- **USE OUTDOOR EXTENSION CORDS.** When tool is used outdoors, use only extension cords with approved ground connection that are intended for use outdoors and so marked.
- **KEEP BLADES CLEAN, SHARP, AND WITH SUFFICIENT SET.** Sharp blades minimize stalling and kickback.
- **NEVER USE IN AN EXPLOSIVE ATMOSPHERE.** Normal sparking of the motor could ignite fumes.
- **INSPECT TOOL CORDS PERIODICALLY.** If damaged, have repaired by a qualified service technician at an authorized service facility. The conductor with insulation having an outer surface that is green with or without yellow stripes is the equipment-grounding conductor. If repair or replacement of the electric cord or plug is necessary, do not connect the equipment-grounding conductor to a live terminal. Repair or replace a damaged or worn cord immediately. Stay constantly aware of cord location and keep it well away from the rotating blade.

GENERAL SAFETY RULES









- **INSPECT EXTENSION CORDS PERIODICALLY** and replace if damaged.
- **KEEP TOOL DRY, CLEAN, AND FREE FROM OIL AND GREASE.** Always use a clean cloth when cleaning. Never use brake fluids, gasoline, petroleum-based products, or any solvents to clean tool.
- **STAY ALERT AND EXERCISE CONTROL.** Watch what you are doing and use common sense. Do not operate tool when you are tired. Do not rush.
- **DO NOT USE TOOL IF SWITCH DOES NOT TURN IT ON AND OFF.** Have defective switches replaced by an authorized service center.
- **INSPECT FOR AND REMOVE ALL NAILS FROM LUMBER BEFORE USING THIS TOOL.** Following this rule will reduce the risk of serious personal injury.
- **NEVER START A TOOL WHEN ANY ROTATING COMPONENT IS IN CONTACT WITH THE WORKPIECE.**
- **DO NOT OPERATE A TOOL WHILE UNDER THE INFLUENCE OF DRUGS, ALCOHOL, OR ANY MEDICATION.**
- **WHEN SERVICING** use only identical replacement parts. Use of any other parts may create a hazard or cause product damage.
- **USE ONLY RECOMMENDED ACCESSORIES** listed in this manual or addendums. Use of accessories that are not listed may cause the risk of personal injury. Instructions for safe use of accessories are included with the accessory.
- **DOUBLE CHECK ALL SETUPS.** Make sure the spindle or sanding belt assembly is tight and not making contact with sander or workpiece before connecting to power supply.

SPECIFIC SAFETY RULES

- **FIRMLY CLAMP OR BOLT** your tool to a workbench or table at approximately hip height.
- **NEVER** stand or have any part of your body in line with the path of the workpiece.
- **PLAN YOUR WORK TO REDUCE THE RISK OF THROWBACKS** (when the workpiece catches the sanding drum and is torn from your hands).
- **MAKE SURE THERE'S NO DEBRIS** between the workpiece and its supports.
- **WHEN SANDING IRREGULARLY SHAPED WORKPIECES,** plan your work support so it will not slip and be pulled from your hands.
- **USE EXTRA CAUTION WITH LARGE,** very small or awkward workpieces.
- **NEVER USE THIS TOOL** to finish pieces too small to hold by hand.
- **USE EXTRA SUPPORTS (TABLES, SAW HORSES, BLOCKS, ETC.)** for any workpieces large enough to tip when not secured to the work surface.
- **NEVER** sand more than one piece at a time. **DO NOT STACK** more than one workpiece on the sander table at a time.
- **ALWAYS FEED WORKPIECE FROM LEFT TO RIGHT** against the direction the drum sleeve is rotating.
- **DO NOT USE DRUMS,** sanding sleeves or belts which show visual signs of wear such as grooves, tears or rips.
- **ALWAYS STAY ALERT!** Do not allow familiarity (gained from frequent use of your sander) to cause a careless mistake. **ALWAYS REMEMBER** that a careless fraction of a second is sufficient to inflict severe injury.
- **MAKE SURE THE WORK AREA HAS AMPLE LIGHTING** to see the work and that no obstructions will interfere with safe operation **BEFORE** performing any work using your tool.
- **ALWAYS TURN OFF THE SANDER** before disconnecting it to avoid accidental starting when reconnecting to power supply. **NEVER** leave the tool unattended while connected to a power source.
- **SUPPORT WORKPIECE** with miter gauge, work rest, or worktable.
- **MAINTAIN 1/16 in.** clearance between worktable and sanding belt or disc.
- **AVOID KICKBACK** by sanding in accordance with directional arrows.
- **IF THE POWER SUPPLY CORD IS DAMAGED,** it must be replaced only by the manufacturer or by an authorized service center to avoid risk.
- **SAVE THESE INSTRUCTIONS.** Refer to them frequently and use them to instruct others who may use this tool. If you loan someone this tool, loan them these instructions also.



SYMBOLS

Some of the following symbols may be used on this tool. Please study them and learn their meaning. Proper interpretation of these symbols will allow you to operate the tool better and safer.

SYMBOL	NAME	DESIGNATION/EXPLANATION
V	Volts	Voltage
A	Amperes	Current
Hz	Hertz	Frequency (cycles per second)
W	Watt	Power
min	Minutes	Time
~	Alternating Current	Type of current
≡	Direct Current	Type or a characteristic of current
n_0	No Load Speed	Rotational speed, at no load
	Class II Construction	Double-insulated construction
.../min	Per Minute	Revolutions, strokes, surface speed, orbits etc., per minute
	Wet Conditions Alert	Do not expose to rain or use in damp locations.
	Read The Operator's Manual	To reduce the risk of injury, user must read and understand operator's manual before using this product.
	Eye Protection	Always wear safety goggles or safety glasses with side shields and, as necessary, a full face shield when operating this product.
	Safety Alert	Precautions that involve your safety.
	No Hands Symbol	Failure to keep your hands away from the blade will result in serious personal injury.
	No Hands Symbol	Failure to keep your hands away from the blade will result in serious personal injury.
	No Hands Symbol	Do not reach across the sanding disc to turn the belt/disc sander ON or OFF. Contact with the sanding disc can result in serious personal injury.
	Hot Surface	To reduce the risk of injury or damage, avoid contact with any hot surface.

SYMBOLS

The following signal words and meanings are intended to explain the levels of risk associated with this product.

SYMBOL	SIGNAL	MEANING
	DANGER:	Indicates an imminently hazardous situation, which, if not avoided, will result in death or serious injury.
	WARNING:	Indicates a potentially hazardous situation, which, if not avoided, could result in death or serious injury.
	CAUTION:	Indicates a potentially hazardous situation, which, if not avoided, may result in minor or moderate injury.
	CAUTION:	(Without Safety Alert Symbol) Indicates a situation that may result in property damage.

SERVICE

Servicing requires extreme care and knowledge and should be performed only by a qualified service technician. For service we suggest you return the product to the nearest **AUTHORIZED SERVICE CENTER** for repair. When servicing, use only identical replacement parts.

WARNING:

To avoid serious personal injury, do not attempt to use this product until you read thoroughly and understand completely the operator's manual. If you do not understand the warnings and instructions in the operator's manual, do not use this product. Call Ryobi customer service for assistance.

WARNING:



The operation of any power tool can result in foreign objects being thrown into your eyes, which can result in severe eye damage. Before beginning power tool operation, always wear safety goggles or safety glasses with side shields and, when needed, a full face shield. We recommend Wide Vision Safety Mask for use over eyeglasses or standard safety glasses with side shields. Always use eye protection which is marked to comply with ANSI Z87.1.

SAVE THESE INSTRUCTIONS

ELECTRICAL

EXTENSION CORDS

Use only 3-wire extension cords that have 3-prong grounding plugs and 3-pole receptacles that accept the tool's plug. When using a power tool at a considerable distance from the power source, use an extension cord heavy enough to carry the current that the tool will draw. An undersized extension cord will cause a drop in line voltage, resulting in a loss of power and causing the motor to overheat. Use the chart provided below to determine the minimum wire size required in an extension cord. Only round jacketed cords listed by Underwriter's Laboratories (UL) should be used.

**Ampere rating (on tool data plate)

	0-2.0	2.1-3.4	3.5-5.0	5.1-7.0	7.1-12.0	12.1-16.0
Cord Length	Wire Size (A.W.G.)					
25'	16	16	16	16	14	14
50'	16	16	16	14	14	12
100'	16	16	14	12	10	—

**Used on 12 gauge - 20 amp circuit.

NOTE: AWG = American Wire Gauge

When working with the tool outdoors, use an extension cord that is designed for outside use. This is indicated by the letters "WA" on the cord's jacket.

Before using an extension cord, inspect it for loose or exposed wires and cut or worn insulation.

WARNING:

Keep the extension cord clear of the working area. Position the cord so that it will not get caught on lumber, tools or other obstructions while you are working with a power tool. Failure to do so can result in serious personal injury.

WARNING:

Check extension cords before each use. If damaged replace immediately. Never use tool with a damaged cord since touching the damaged area could cause electrical shock resulting in serious injury.

ELECTRICAL CONNECTION

This tool is powered by a precision-built electric motor. It should be connected to a **power supply that is 120 volts, 60 Hz, AC only (normal household current)**. Do not operate this tool on direct current (DC). A substantial voltage drop will cause a loss of power and the motor will overheat. If the tool does not operate when plugged into an outlet, double check the power supply.

SPEED AND WIRING

The belt speed of this tool is approximately 1,900 SFM. This speed is not constant and decreases under a load or with lower voltage. For voltage, the wiring in a shop is as important as the motor's horsepower rating. A line intended only for lights cannot properly carry a power tool motor. Wire that is heavy enough for a short distance will be too light for a greater distance. A line that can support one power tool may not be able to support two or three tools.

GROUNDING INSTRUCTIONS

In the event of a malfunction or breakdown, grounding provides a path of least resistance for electric current to reduce the risk of electric shock. This tool is equipped with an electric cord having an equipment-grounding conductor and a grounding plug. The plug must be plugged into a matching outlet that is properly installed and grounded in accordance with all local codes and ordinances.

Do not modify the plug provided. If it will not fit the outlet, have the proper outlet installed by a qualified electrician. Improper connection of the equipment-grounding conductor can result in a risk of electric shock. The conductor with insulation having an outer surface that is green with or without yellow stripes is the equipment-grounding conductor. If repair or replacement of the electric cord or plug is necessary, do not connect the equipment-grounding conductor to a live terminal.

Check with a qualified electrician or service personnel if the grounding instructions are not completely understood, or if in doubt as to whether the tool is properly grounded.

Repair or replace a damaged or worn cord immediately.

This tool is intended for use on a circuit that has an outlet like the one shown in figure 1. It also has a grounding pin like the one shown.

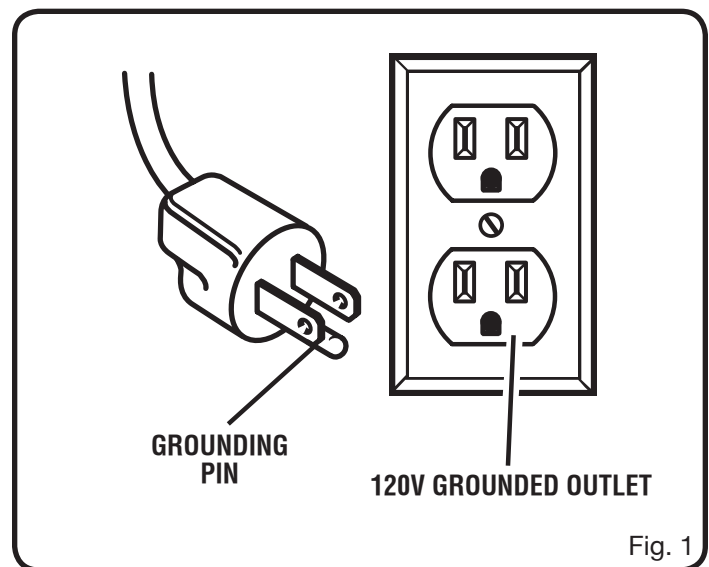

Fig. 1

GLOSSARY OF TERMS

Anti-Kickback Pawls (radial arm and table saws)

A device which, when properly installed and maintained, is designed to stop the workpiece from being kicked back toward the front of the saw during a ripping operation.

Arbor

The shaft on which a blade or cutting tool is mounted.

Bevel Cut

A cutting operation made with the blade at any angle other than 90° to the table surface.

Chamfer

A cut removing a wedge from a block so the end (or part of the end) is angled rather than at 90°.

Compound Cut

A cross cut made with both a miter and a bevel angle.

Cross cut

A cutting or shaping operation made across the grain or the width of the workpiece.

Cutterhead (planers and jointer planers)

A rotating cutterhead with adjustable blades or knives. The blades or knives remove material from the workpiece.

Dado Cut

A non-through cut which produces a square-sided notch or trough in the workpiece (requires a special blade).

Featherboard

A device used to help control the workpiece by guiding it securely against the table or fence during any ripping operation.

FPM or SPM

Feet per minute (or strokes per minute), used in reference to blade movement.

Freehand

Performing a cut without the workpiece being guided by a fence, miter gauge, or other aids.

Gum

A sticky, sap-based residue from wood products.

Heel

Alignment of the blade to the fence.

Kerf

The material removed by the blade in a through cut or the slot produced by the blade in a non-through or partial cut.

Kickback

A hazard that can occur when the blade binds or stalls, throwing the workpiece back toward operator.

Leading End

The end of the workpiece pushed into the tool first.

Miter Cut

A cutting operation made with the workpiece at any angle to the blade other than 90°.

Non-Through Cuts

Any cutting operation where the blade does not extend completely through the thickness of the workpiece.

Push Blocks (for jointer planers)

Device used to feed the workpiece over the jointer planer cutterhead during any operation. This aid helps keep the operator's hands well away from the cutterhead.

Push Blocks and Push Sticks (for table saws)

Devices used to feed the workpiece through the saw blade during cutting operations. A push stick (not a push block) should be used for narrow ripping operations. These aids help keep the operator's hands well away from the blade.

Pilot Hole (drill presses)

A small hole drilled in a workpiece that serves as a guide for drilling large holes accurately.

Resaw

A cutting operation to reduce the thickness of the workpiece to make thinner pieces.

Resin

A sticky, sap-based substance that has hardened.

Revolutions Per Minute (RPM)

The number of turns completed by a spinning object in one minute.

Ripping or Rip Cut

A cutting operation along the length of the workpiece.

Riving Knife/Spreader/Splitter (table saws)

A metal piece, slightly thinner than the blade, which helps keep the kerf open and also helps to prevent kickback.

Saw Blade Path

The area over, under, behind, or in front of the blade. As it applies to the workpiece, that area which will be or has been cut by the blade.

Set

The distance that the tip of the saw blade tooth is bent (or set) outward from the face of the blade.

Snipe (planers)

Depression made at either end of a workpiece by cutter blades when the workpiece is not properly supported.

Through Sawing

Any cutting operation where the blade extends completely through the thickness of the workpiece.

Throw-Back

The throwing back of a workpiece usually caused by the workpiece being dropped into the blade or being placed inadvertently in contact with the blade.

Workpiece or Material

The item on which the operation is being done.

Worktable

Surface where the workpiece rests while performing a cutting, drilling, planing, or sanding operation.

FEATURES

PRODUCT SPECIFICATIONS

Belt Size 4 in. x 36 in.
Belt Speed..... 1,900 SFM
Belt Tilt 0°- 90°
Disc Size..... 6 in.
Disc Speed 3,600 r/min. (RPM)

Table Size 8-1/2 in. x 5-3/4 in.
Table Tilt 0°- 45°
Input 120 V, AC only, 60 Hz, 4.3 Amps
Motor 1/2 HP Induction
Net Weight..... 53 lbs.

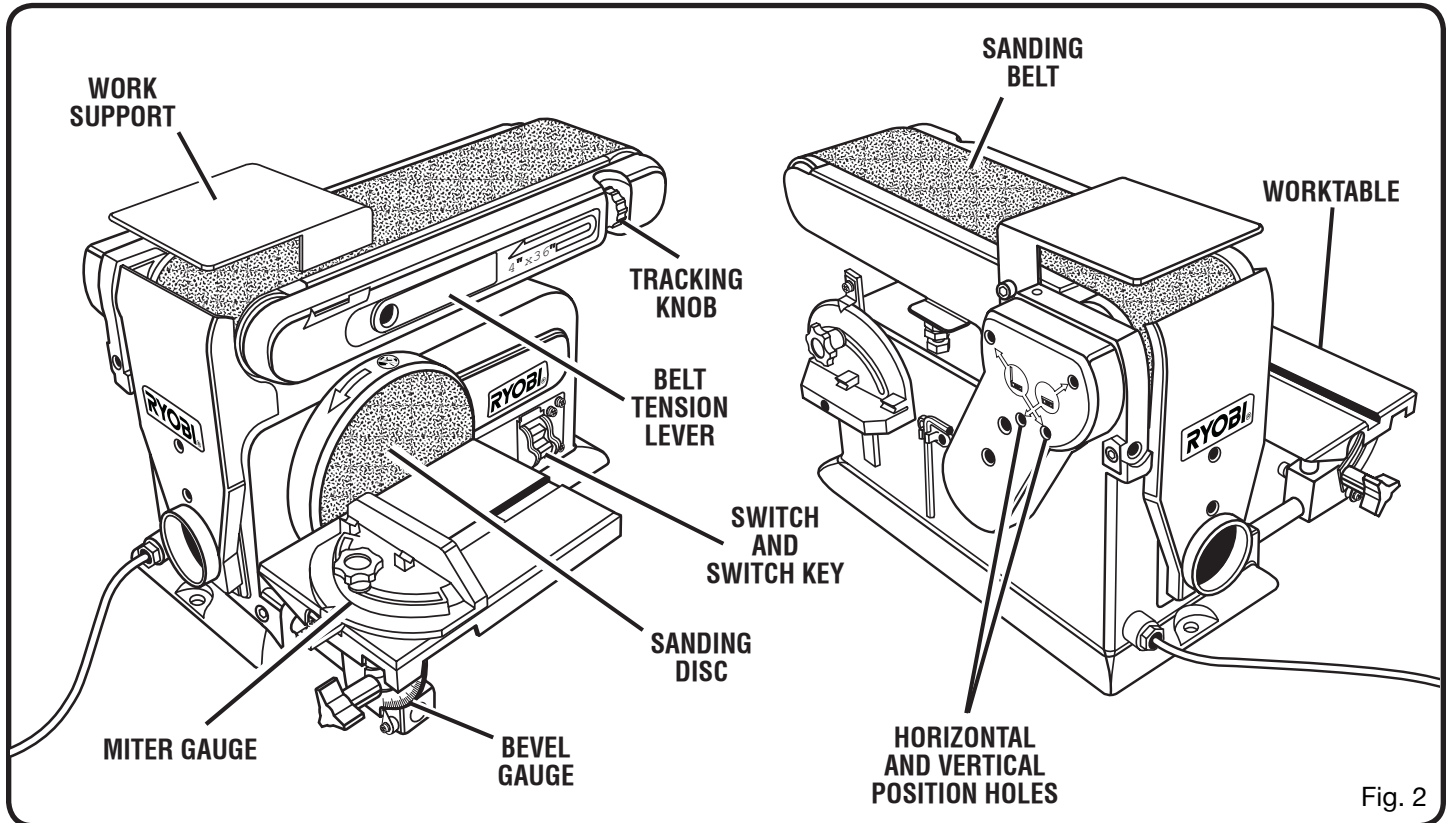

Fig. 2

KNOW YOUR BELT/DISC SANDER

See Figure 2.

The safe use of this product requires an understanding of the information on the tool and in this operator's manual as well as a knowledge of the project you are attempting. Before use of this product, familiarize yourself with all operating features and safety rules.

BELT TENSION LEVER

The belt tension lever releases the belt tension for easy belt replacement.

BEVEL GAUGE

The worktable comes equipped with a bevel gauge that indicates the degrees the worktable can be tilted up to 45°.

HORIZONTAL AND VERTICAL POSITION HOLES

The horizontal and vertical position holes are used for changing the position of the belt from horizontal to vertical.

MITER GAUGE

The miter gauge aligns the wood for positive stops at 90° and 45°.

SANDING BELT

The sanding belt can be adjusted from horizontal to vertical providing different positions for sanding workpieces of different shapes and sizes.

SANDING DISC

A round sanding disc is located on the side of the belt/disc sander.

SWITCH AND SWITCH KEY

Your belt/disc sander has an easy access power switch.

TRACKING KNOB

A tracking knob aids in centering the sanding belt.

WORK SUPPORT

Supports the workpiece on the sanding belt.

WORKTABLE

Equipped with a sturdy worktable that provides a stable surface when using either the disc sanding or the belt sanding feature.

FEATURES

⚠ WARNING:

Do not reach across the sanding disc to turn the belt/disc sander **ON** or **OFF**. Contact with the sanding disc can result in serious personal injury.

⚠ WARNING:

Before performing any adjustment, make sure the tool is unplugged from the power supply and the switch is in the **OFF (O)** position. Failure to heed this warning could result in serious personal injury.

POWER SWITCH

See Figure 3.

The belt/disc sander is equipped with a power switch that has a built-in locking feature. This feature is intended to prevent unauthorized and possible hazardous use by children and others.

TO TURN THE BELT/DISC SANDER ON:

- With the switch key inserted into the switch, lift the switch button to turn **ON**.

TO TURN THE BELT/DISC SANDER OFF:

- Press the switch button down to turn **OFF**.

⚠ WARNING:

In the event of a power failure or when the tool is not in use, turn the switch **OFF** and remove the switch key. This action will prevent the tool from accidentally starting when power returns.

⚠ WARNING:

ALWAYS make sure your workpiece is not in contact with the belt before operating the switch to start the tool. Failure to heed this warning may cause the workpiece to be kicked back toward the operator and result in serious personal injury.

⚠ WARNING:

To reduce the risk of accidental starting, ALWAYS make sure the switch is in the **OFF** position before plugging tool into the power source.

LOCKING THE SWITCH

See Figure 4.

- Place the switch in the **OFF** position.
- Wait until the belt/disc sander has come to a full and complete stop.
- Remove the switch key from the switch assembly. Store key in safe place.

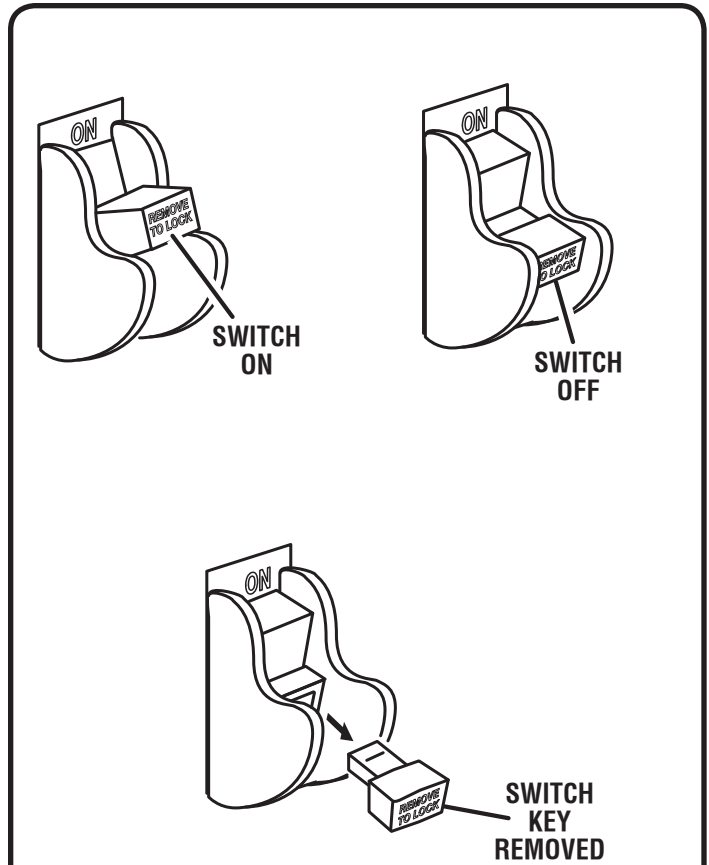

Fig. 3

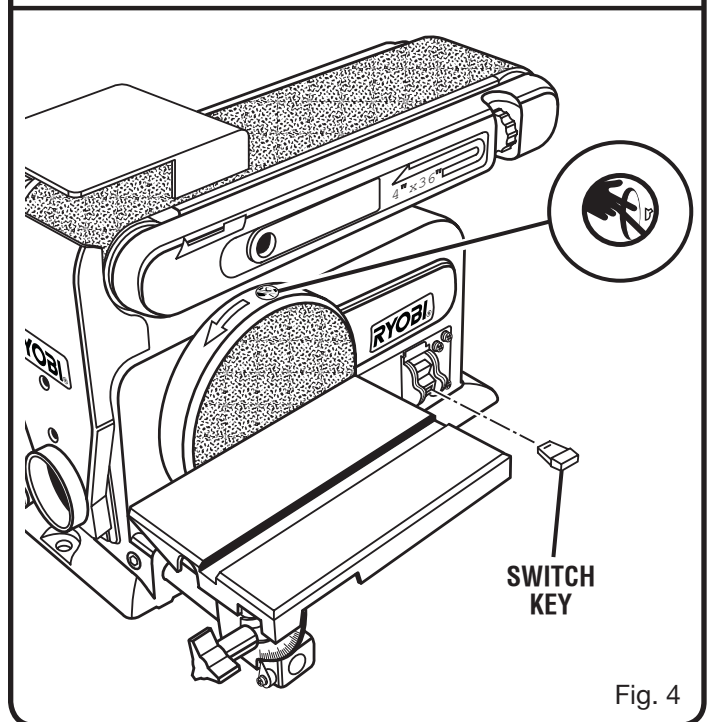

Fig. 4

LOOSE PARTS

The following items are included with the tool:

- Sanding Disc
- Disc Guard
- Phillips Screws (2)
- Socket Head Screws, M8 x 12 (2)
- Washers (2)
- Miter Gauge
- Hex Key
- Worktable
- Work Support
- Operator's Manual (not shown)

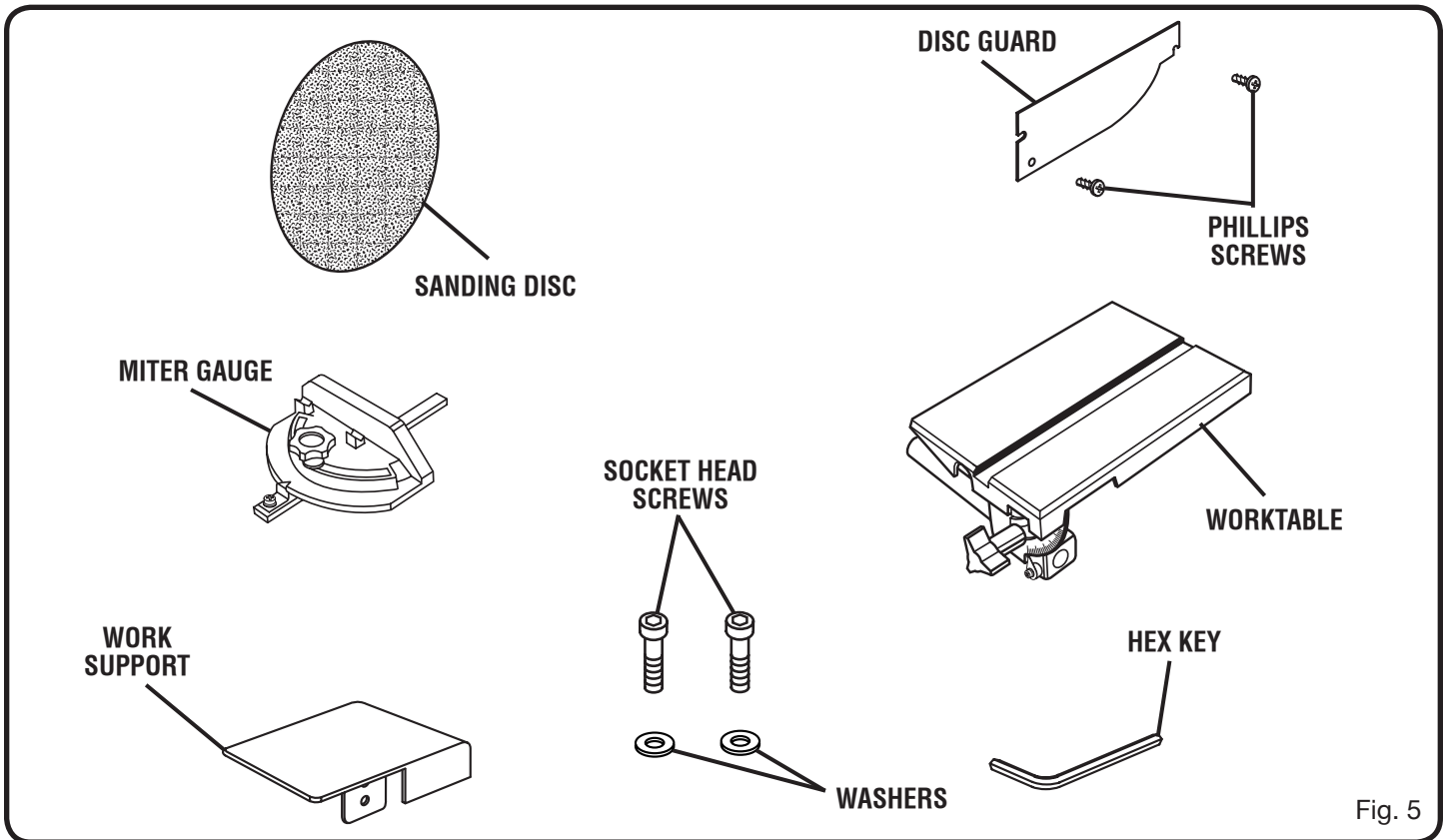

Fig. 5

ASSEMBLY

UNPACKING

This product requires assembly.

- Carefully remove the tool and any accessories from the box. Make sure that all items listed in the packing list are included.
- Inspect the tool carefully to make sure no breakage or damage occurred during shipping.
- Do not discard the packing material until you have carefully inspected and satisfactorily operated the tool.
- If any parts are damaged or missing, please call 1-800-525-2579 for assistance.

⚠ WARNING:

If any parts are damaged or missing do not operate this tool until the parts are replaced. Failure to heed this warning could result in serious personal injury.

⚠ WARNING:

Do not attempt to modify this tool or create accessories not recommended for use with this tool. Any such alteration or modification is misuse and could result in a hazardous condition leading to possible serious personal injury.

⚠ WARNING:

Do not connect to power supply until assembly is complete. Failure to comply could result in accidental starting and possible serious personal injury.

ASSEMBLY

INSTALLING SANDING DISC AND DISC GUARD

See Figure 6.

- Unplug the belt/disc sander.
- Remove the backing from the sanding disc.
- Align perimeter of sanding disc with plate and press firmly into position.
- Position disc guard against the lower one-third of the disc, aligning holes as shown in figure 6.
- Using the two phillips head screws, securely tighten the disc guard into place.

INSTALLING/REPLACING SANDING BELT

See Figure 7.

On the smooth side of the sanding belt, there is a directional arrow. The sanding belt must run in the direction of the arrow.

- Unplug the belt/disc sander.
- Pull the belt tension lever toward you to release belt tension.
- Place the sanding belt over the drive roller and idler roller with the directional arrows running counterclockwise. Be sure the sanding belt is centered on both drums.
- Push the belt tension lever back into place to apply the belt tension.

NOTE: The belt tension lever is spring loaded; use extreme caution when pushing the tension lever back into place to avoid personal injury.

MOUNTING THE WORKTABLE FOR USE WITH THE DISC SANDER

See Figure 8.

- Unplug the belt/disc sander.
- Insert the index pin into the hole as shown in figure 8.
- Position the worktable no farther than 1/16 in. from the sanding surface.
- Using a hex key, tighten the hex set screw securely.

MOUNTING THE WORKTABLE FOR USE WITH THE BELT SANDER

See Figure 9.

- Unplug the belt/disc sander.
- Insert the index pin into the hole as shown in figure 9.
- Position the worktable no farther than 1/16 in. from the sanding surface.
- Using a hex key, tighten the hex set screw securely.

CAUTION:

To avoid trapping the workpiece or your fingers between the table and sanding surface, the table edge should NEVER be further from the sanding surface than 1/16 in.

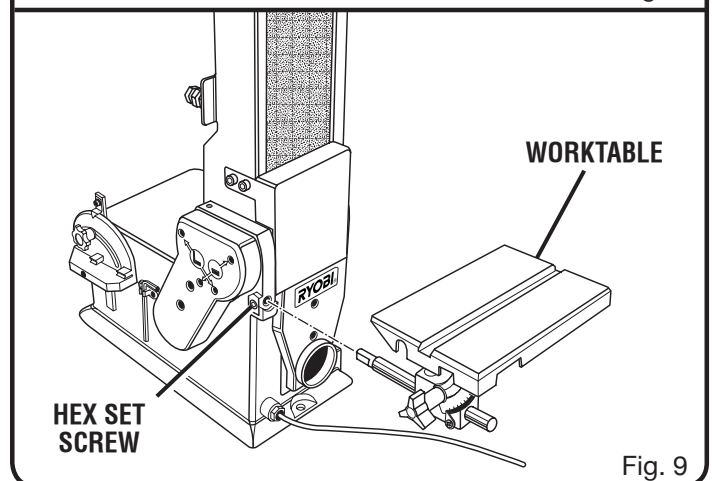
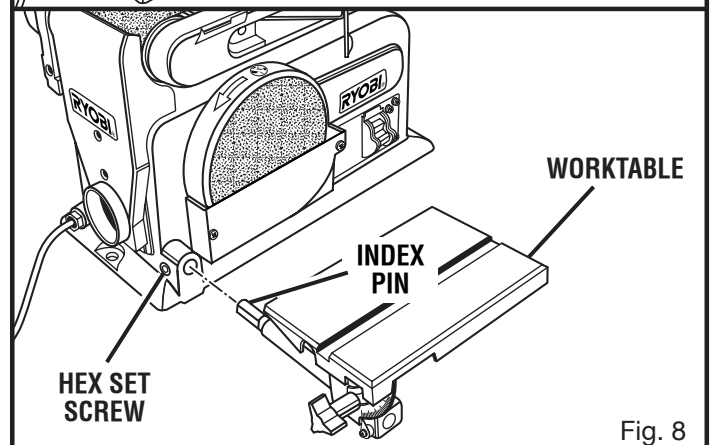
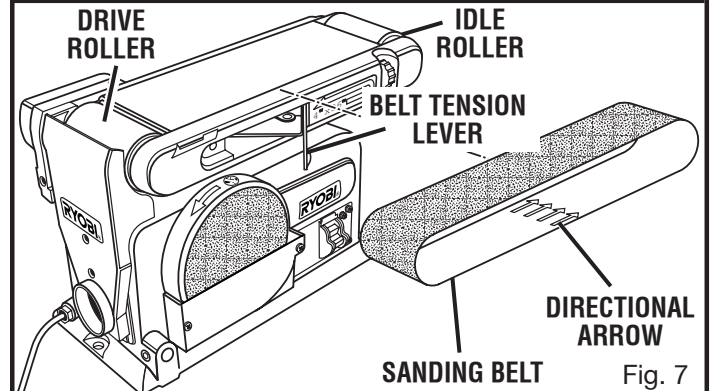
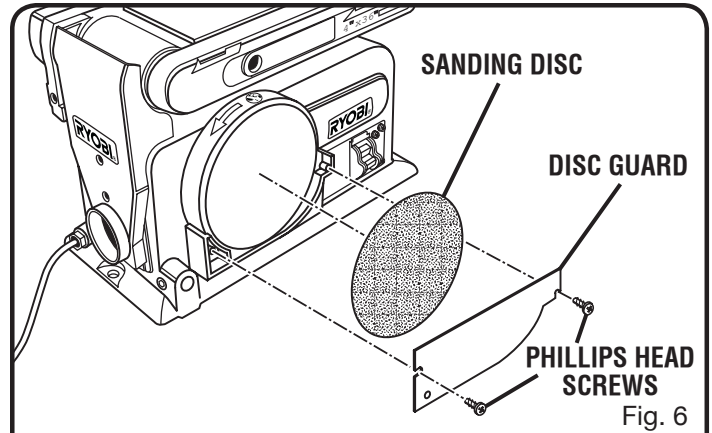

ASSEMBLY

ASSEMBLING WORK SUPPORT

See Figure 10.

- Place the work support over the holes in the side of the tool housing.
- Using a hex key, fasten in place with the washers and socket head screws.

MOUNTING BELT/DISC SANDER TO WORKBENCH

See Figure 11.

If the belt/disc sander is to be used in a permanent location, it is recommended you secure it to a workbench or other stable surface. When mounting the belt/disc sander to a workbench, holes should be drilled through the supporting surface of the workbench.

- Mark holes on workbench where belt/disc sander is to be mounted using holes in the base as a template for hole pattern.
- Drill holes through workbench.
- Place belt/disc sander on workbench aligning holes in the base with holes drilled in the workbench.
- Insert bolts (not included) and tighten securely with lock washers and hex nuts (not included).

NOTE: All bolts should be inserted from the top. Install the lock washers and hex nuts from the underside of the workbench.

CLAMPING BELT/DISC SANDER TO WORKBENCH

See Figure 12.

If the belt/disc sander is to be used as a portable tool, it is recommended you fasten it permanently to a mounting board that can easily be clamped to a workbench or other stable surface. The mounting board should be of sufficient size to avoid tipping while belt/disc sander is in use. Any good grade plywood or chipboard with a 3/4 in. thickness is recommended.

- Mark holes on board where belt/disc sander is to be mounted using holes in the base as a template for hole pattern.
- Follow the last three steps in section **Mounting Belt/Disc Sander to Workbench.**

If lag bolts are used, make sure they are long enough to go through holes in belt/disc sander base and material the belt/disc sander is being mounted to. If machine bolts are used, make sure bolts are long enough to go through holes in belt/disc sander, the material being mounted to, and the lock washers and hex nuts.

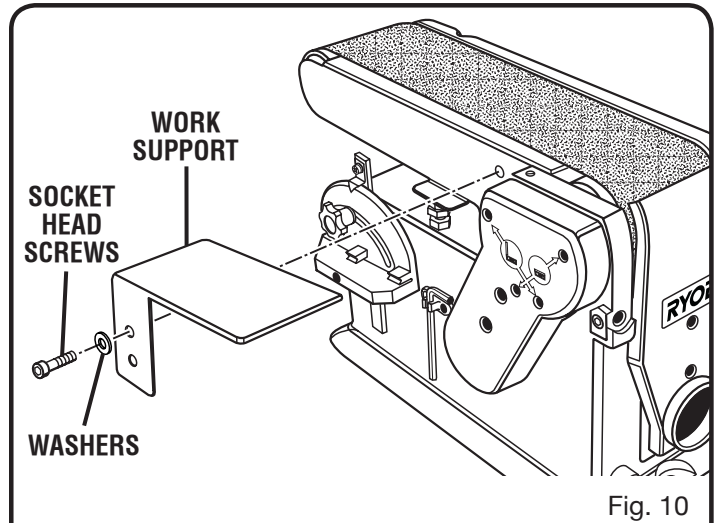

Fig. 10

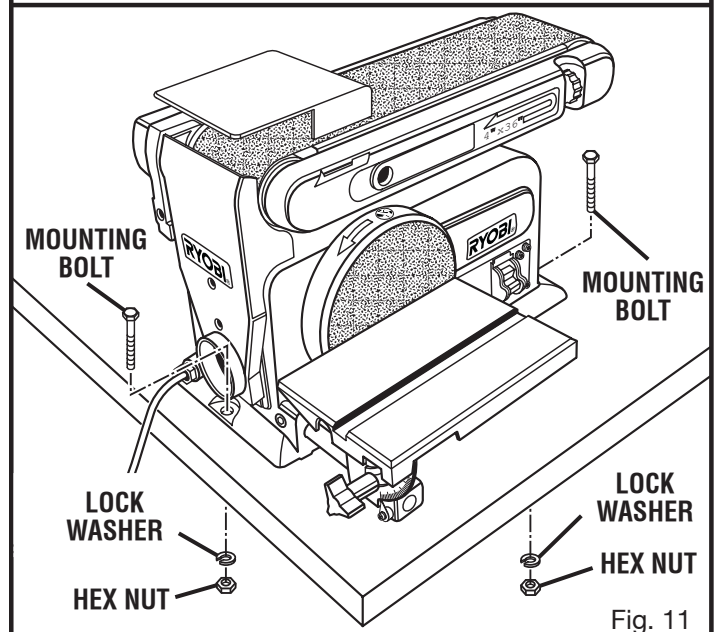

Fig. 11

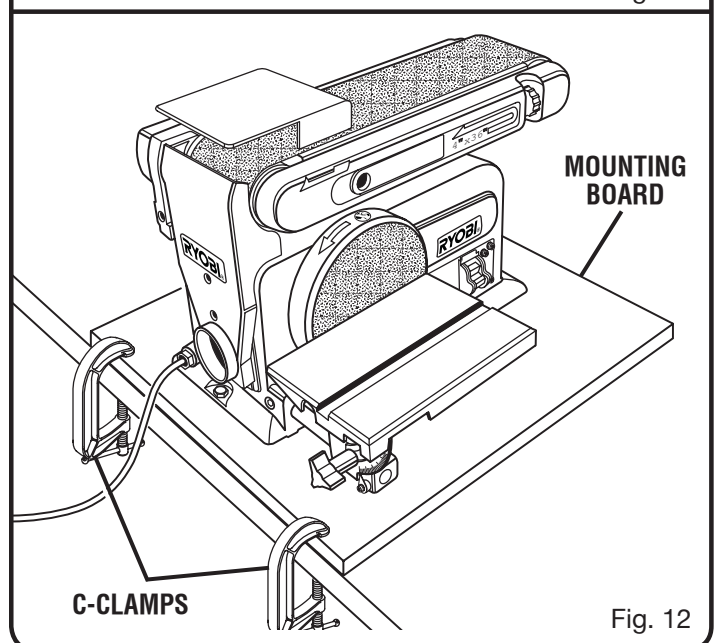

Fig. 12

OPERATION

⚠ WARNING:

Do not allow familiarity with tools to make you careless. Remember that a careless fraction of a second is sufficient to inflict serious injury.

⚠ WARNING:

Always wear safety goggles or safety glasses with side shields when operating power tools. Failure to do so could result in objects being thrown into your eyes resulting in possible serious injury.

⚠ WARNING:

Do not use any attachments or accessories not recommended by the manufacturer of this tool. The use of attachments or accessories not recommended can result in serious personal injury.

APPLICATIONS

You may use this tool for the purpose listed below:

- Sanding and finishing plastic, wood, and wood composition materials
- Bevel sanding
- Horizontal and vertical sanding
- Sanding curved pieces

⚠ WARNING:

Applying the workpiece to the right side of the sanding disc could cause the workpiece to kickback. Failure to heed this warning could result in serious personal injury.

BEVEL SANDING

See Figure 13.

The worktable can be tilted from 0° to 45° for bevel sanding. To tilt the worktable:

- Loosen the table lock knob by turning it counterclockwise.
- Set worktable to desired angle. Position the worktable no farther than 1/16 in. from the sanding surface.
- Tighten the table lock knob by turning it clockwise.

SANDING SMALL END SURFACES USING THE MITER GAUGE

See Figure 14.

A miter gauge is included with the tool for increased accuracy. Use of a miter gauge is recommended for sanding small end surfaces on the sanding disc.

NOTE: Always move the workpiece across the sanding disc from the left side toward the center.

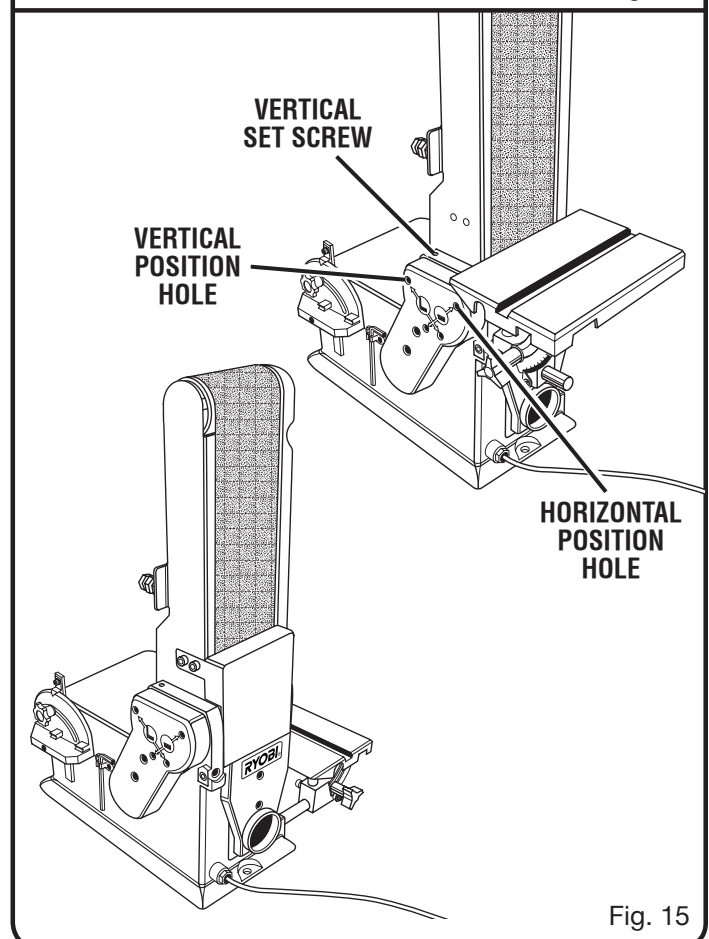
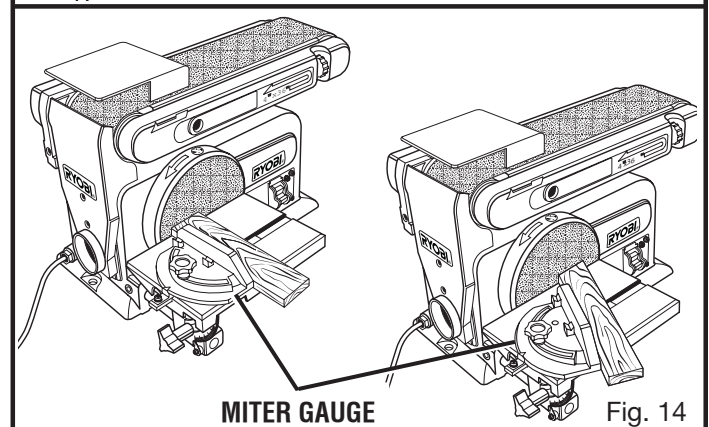
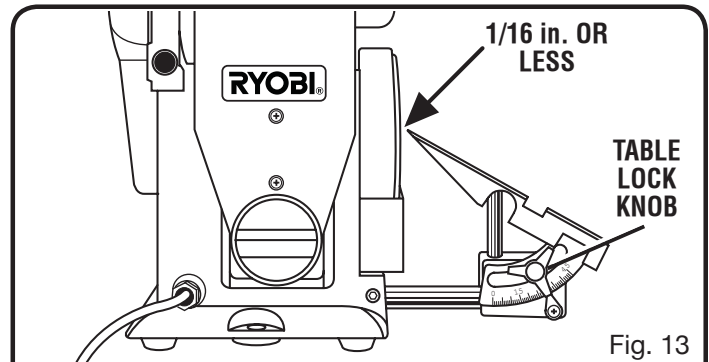

OPERATION

HORIZONTAL AND VERTICAL SANDING

See Figure 15.

The belt/disc sander can sand both vertically and horizontally. Depending on the workpiece, the work support can be used with either the horizontal or vertical sanding operation.

- Insert the hex key provided into the holes in the pulley cover. Loosen the screws by turning them counter-clockwise.
- Move the sanding belt into a vertical position as shown in figure 15. Vertical position can be adjusted using the vertical set screw.
- Lock the sanding belt by retightening the screws.

NOTE: Sand long workpieces with the sanding belt in the vertical position by moving the work evenly across the sanding belt.

SURFACE SANDING ON THE SANDING BELT

See Figure 16.

- Hold the workpiece firmly, keeping fingers away from the sanding belt.
- Keep the end pressed firmly against the work support moving work evenly across the sanding belt.

NOTE: Use extra caution when sanding very thin pieces. When sanding extra long pieces, remove the work support. Apply only enough pressure to allow the sanding belt to remove the material.

SANDING CURVED PIECES

See Figures 17 - 18.

WARNING:

Never attempt to sand the end pieces of a workpiece on the idler drum. Applying the end of the workpiece on the idler drum could cause the workpiece to fly up. Failure to heed this warning could result in serious personal injury.

Sanding inside curves on the sanding belt:

Always sand inside curves on the idler drum as shown in figure 17.

- Hold the workpiece firmly, keeping fingers away from the sanding belt.
- Keep the curve pressed firmly against the idler drum moving work evenly across the sanding belt.

NOTE: Use extra caution when sanding very thin pieces and apply only enough pressure to allow the sanding belt to remove the material.

Sanding outside curves on the sanding disc:

Always sand outside curves using the sanding disc and moving the workpiece from the left side of center as shown in figure 18.

- Hold the workpiece firmly, keeping fingers away from the sanding disc.
- Keep the curve pressed firmly against the sanding disc moving work evenly on the left side of the sanding disc.

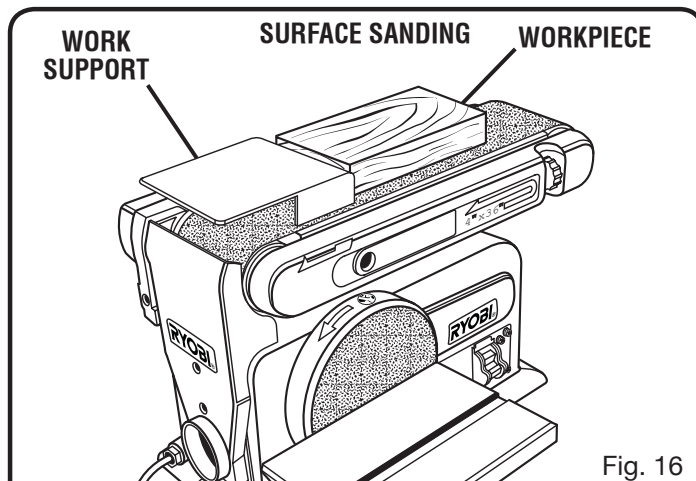

Fig. 16

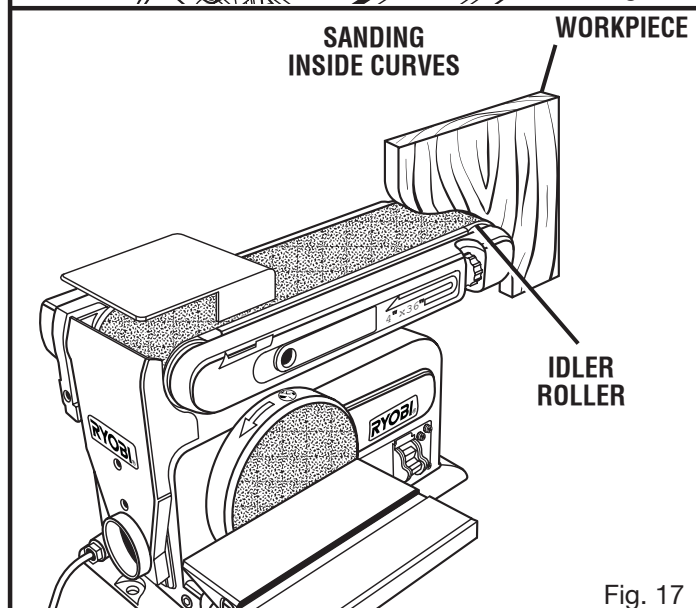

Fig. 17

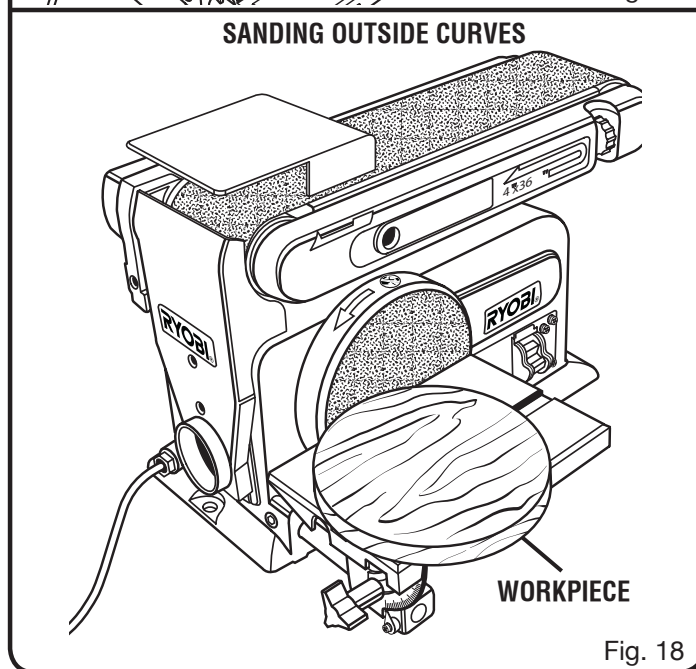

Fig. 18

ADJUSTMENTS

⚠ WARNING:

Before performing any adjustment, make sure the tool is unplugged from the power supply and the switch is in the **OFF (O)** position. Failure to heed this warning could result in serious personal injury.

ADJUSTING THE BELT TRACKING

See Figure 19.

- Plug in belt/disc sander.

To check belt tracking:

- Turn the switch **ON** and then immediately turn it **OFF**. If the belt tends to slide off the idler drum or drive drum, the belt is not tracking properly.

To adjust belt tracking:

- If the sanding belt moves toward the disc, turn the tracking knob clockwise 1/4 turn.
- If the sanding belt moves away from the disc, turn the tracking knob counterclockwise 1/4 turn.
- Turn the switch **ON** and then immediately **OFF** again, noting belt movement. Readjust tracking knob if necessary.

SQUARING THE WORKTABLE TO THE SANDING DISC

See Figure 20.

- Unplug the belt/disc sander.
- Using a combination square, check the angle of the worktable with the sanding belt.
- If the worktable is not 90° with the disc, loosen the table lock knob and tilt the table.
- Adjust worktable square to the sanding disc and retighten the table lock knob.

NOTE: Use the adjustment screws beneath the worktable to move the table further or closer to the sanding disc.

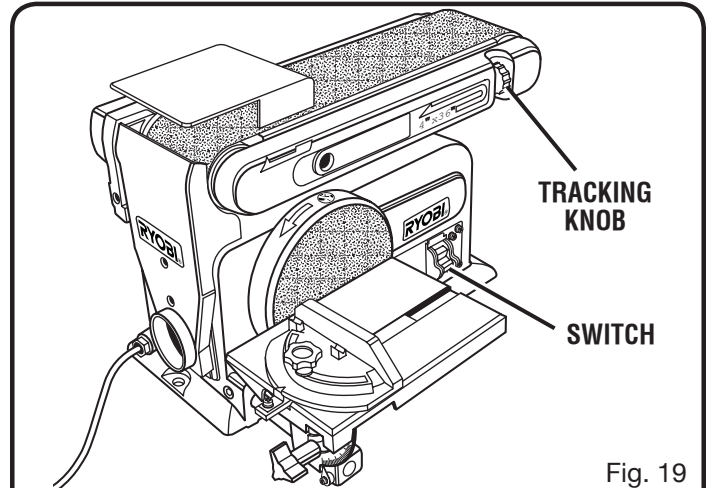

Fig. 19

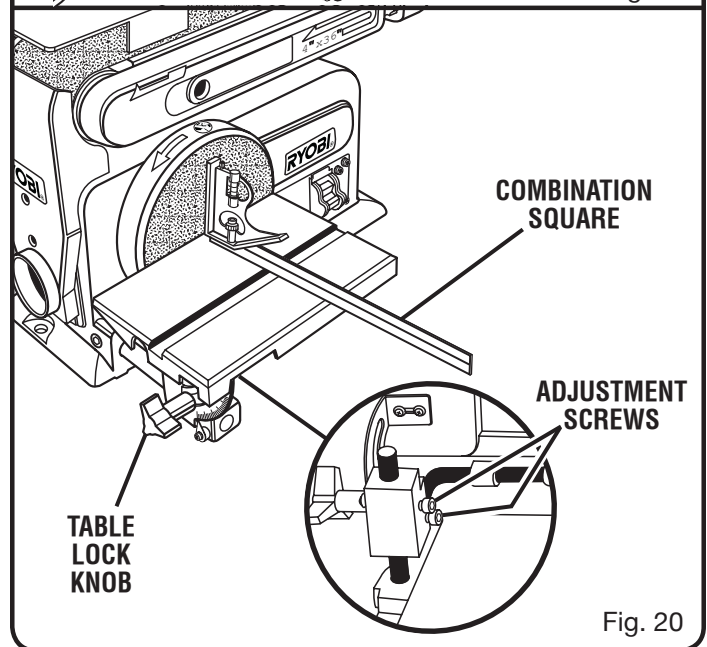

Fig. 20

MAINTENANCE

WARNING:

When servicing, use only identical replacement parts. Use of any other parts may create a hazard or cause product damage.

WARNING:

Always wear safety goggles or safety glasses with side shields during power tool operation or when blowing dust. If operation is dusty, also wear a dust mask.

WARNING:

Do not at any time let brake fluids, gasoline, petroleum-based products, penetrating oils, etc., come in contact with plastic parts. Chemicals can damage, weaken or destroy plastic which may result in serious personal injury.

GENERAL MAINTENANCE

Avoid using solvents when cleaning plastic parts. Most plastics are susceptible to damage from various types of commercial solvents and may be damaged by their use. Use clean cloths to remove dirt, dust, oil, grease, etc.

WARNING:

To prevent accidental starting that could cause possible serious personal injury, turn off the tool, remove the switch key, and unplug the belt sander before performing any maintenance or adjustment.

Electric tools used on fiberglass material, wallboard, spackling compounds, or plaster are subject to accelerated wear and possible premature failure because the fiberglass chips and grindings are highly abrasive to bearings, brushes, commutators, etc. Consequently, we do not recommend using this tool for extended work on these types of materials. However, if you do work with any of these materials, it is extremely important to clean the tool using compressed air.

LUBRICATION

All of the bearings in this tool are lubricated with a sufficient amount of high grade lubricant for the life of the unit under normal operating conditions. Therefore, no further lubrication is required.

CHANGING DRIVE BELT

See Figure 21.

- Unplug the belt/disc sander.
- Using a phillips head screwdriver, remove the two screws in the center of the pulley cover and the motor cover screws.
- Remove the covers.
- Loosen motor cover.
- Raise sanding belt to the vertical sanding position
- Next, loosen the hex head set screw. Raising the motor pulley releases the belt tension.

- Remove the old drive belt.
 - Fit the new drive belt on the drive pulley first and then on the motor pulley.
 - Test belt tension by squeezing the belt with your fingers.
 - Adjust the belt tension with the hex head set screw until there is about 1/4 in. of give.
 - Tighten the belt tension nut securely.
 - Adjust the motor bracket so that it holds the motor against the hex nut.
- NOTE:** Excessive tightness on the drive belt may cause increased noise and overload the motor. Excessive looseness on the drive belt (and improper adjustment of the motor bracket) may cause the drive belt to fail prematurely and make a severe chattering noise.
- Using a phillips head screwdriver, reinstall the pulley cover and the two phillips head screws. Tighten securely.
 - Replace the motor cover with the four screws, washers, and rubber feet.

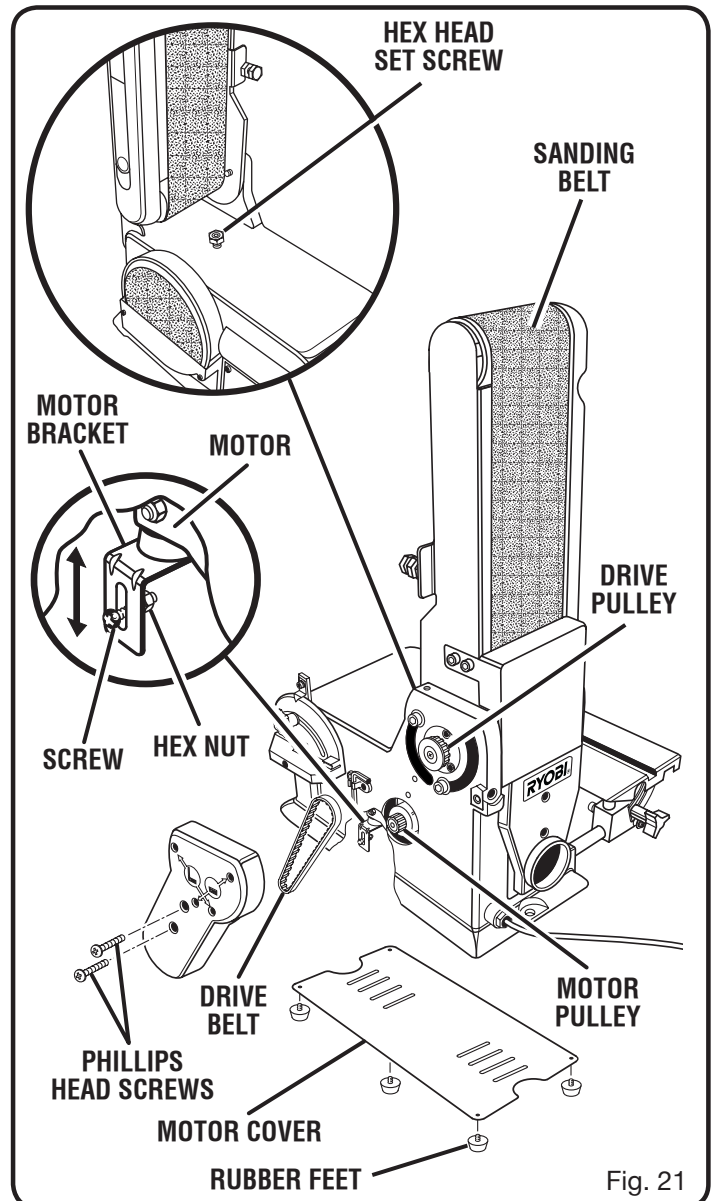

Fig. 21



OPERATOR'S MANUAL

BELT/DISC SANDER

BD4600

WARNING:

Some dust created by power sanding, sawing, grinding, drilling, and other construction activities contains chemicals known to cause cancer, birth defects or other reproductive harm. Some examples of these chemicals are:

- lead from lead-based paints,
- crystalline silica from bricks and cement and other masonry products, and
- arsenic and chromium from chemically-treated lumber.

Your risk from these exposures varies, depending on how often you do this type of work. To reduce your exposure to these chemicals: work in a well ventilated area, and work with approved safety equipment, such as those dust masks that are specially designed to filter out microscopic particles.

• **SERVICE**

Now that you have purchased your tool, should a need ever exist for repair parts or service, simply contact your nearest Authorized Service Center. Be sure to provide all pertinent facts when you call or visit. Please call 1-800-525-2579 for your nearest Authorized Service Center. You can also check our web site at www.ryobitools.com for a complete list of Authorized Service Centers.

• **MODEL NO. AND SERIAL NO.**

The model number of this tool will be found on a plate attached to the motor housing. Please record the model number and serial number in the space provided below.

• **HOW TO ORDER REPAIR PARTS**

When ordering repair parts, always give the following information:

- MODEL NUMBER BD4600
- SERIAL NUMBER _____

Ryobi® is a registered trademark of Ryobi Limited used under license.

ONE WORLD TECHNOLOGIES, INC.

1428 Pearman Dairy Road, Anderson, SC 29625

Phone 1-800-525-2579

www.ryobitools.com