

# **RYOBI** OPERATOR'S MANUAL 10 in. (254 mm) TABLE SAW Model BTS10



## **THANK YOU FOR BUYING A RYOBI TABLE SAW.**

Your new Table Saw has been engineered and manufactured to Ryobi's high standards for dependability, ease of operation, and operator safety. Properly cared for, it will give you years of rugged, trouble-free performance.



**CAUTION:** Carefully read through this entire operator's manual before using your new table saw.

Pay close attention to the Rules for Safe Operation, Warnings, and Cautions. If you use your table saw properly and only for what it is intended, you will enjoy years of safe, reliable service.

Please fill out and return the Warranty Registration Card so we can be of future service to you.

Thank you again for buying Ryobi tools.

**SAVE THIS MANUAL FOR FUTURE REFERENCE**

# TABLE OF CONTENTS

Table of Contents .....	2
Rules for Safe Operation .....	3-5
Specific Safety Rules for the BTS10 Table Saw .....	5-6
Glossary of Woodworking Terms .....	6-7
Unpacking and Checking Contents .....	8
List of Loose Parts .....	8
Features .....	9
Assembly .....	10-11
Tools Needed .....	10
Assembling the Blade Control Handle .....	10
Attaching Blade Guard Assembly .....	10
Install Miter Gauge .....	11
Installing the Rip Fence Lock Down Handle .....	11
Installing the Rip Fence .....	11
General Information .....	12
On/Off Switch Key .....	12
Grounding .....	12
Overload Reset Button .....	12
Speed and Wiring .....	12
Adjustments .....	13-14
Calibrating and Adjusting Your Saw .....	13
Checking/Adjusting Saw Blade and Blade Guard Assembly Alignment .....	13
Bevel Adjustments .....	13
Checking 90° and 45° Positive Stops .....	13
To Adjust the 90° Positive Stop .....	13
To Adjust the 45° Positive Stop .....	14
To Adjust the Blade Height .....	14
To Adjust the Rip Fence .....	14
To Adjust the Miter Gauge .....	14
Operation .....	15-20
Making Cuts .....	15
Cutting Tips .....	16
To Make a Rip Cut .....	16
To Make a Cross Cut .....	16-17
To Make a Miter Cross Cut .....	17
To Make a Bevel Cross Cut .....	17
To Make a Bevel Rip Cut .....	18
To Make a Compound Miter Cross Cut .....	18
To Make Non-Through Cuts .....	18-19
Push Sticks .....	19
Safety Considerations .....	20
Maintenance .....	21
General Maintenance .....	21
Specific Table Saw Maintenance .....	21
Troubleshooting .....	22
Parts Ordering / Service .....	24

# RULES FOR SAFE OPERATION

The purpose of safety symbols is to attract your attention to possible dangers. The safety symbols, and the explanations with them, deserve your careful attention and understanding. The safety warnings do not by themselves eliminate any danger. The instructions or warnings they give are not substitutes for proper accident prevention measures.

SYMBOL

MEANING



**SAFETY ALERT SYMBOL:**

Indicates danger, warning, or caution. May be used in conjunction with other symbols or pictographs.



**DANGER:** Failure to obey a safety warning will result in serious injury to yourself or to others. Always follow the safety precautions to reduce the risk of fire, electric shock and personal injury.



**WARNING:** Failure to obey a safety warning can result in serious injury to yourself or to others. Always follow the safety precautions to reduce the risk of fire, electric shock and personal injury.



**CAUTION:** Failure to obey a safety warning may result in property damage or personal injury to yourself or to others. Always follow the safety precautions to reduce the risk of fire, electric shock and personal injury.

**NOTE:**

Advises you of information or instructions vital to the operation or maintenance of the equipment.

## IMPORTANT

Servicing requires extreme care and knowledge and should be performed only by a qualified service technician. For service we suggest you return the tool to your nearest **RYOBI AUTHORIZED SERVICE CENTER** for repair. When servicing, use only identical Ryobi replacement parts.



### WARNING:

Observe all normal safety precautions related to avoiding electrical shock.



### WARNING:

Do not attempt to operate this tool until you have read thoroughly and understand completely all instructions, safety rules, etc. contained in this manual. Failure to comply can result in accidents involving fire, electric shock, or serious personal injury. Save this operator's manual and review frequently for continuing safe operation and instructing others who may use this tool.



### WARNING:

Keep hands away from blade at all times.



### WARNING:



The operation of any table saw can result in foreign objects being thrown into your eyes, which can result in severe eye damage. Before beginning power tool operation, always wear safety goggles or safety glasses with side shields and a full face shield when needed. We recommend Wide Vision Safety Mask for use over eyeglasses or standard safety glasses with side shields.



**Look for this symbol to point out important safety precautions. It means attention!!! Your safety is involved.**

# RULES FOR SAFE OPERATION

## READ AND UNDERSTAND ALL INSTRUCTIONS

1. **Know your power tool.** Read and understand the operator's manual carefully. Learn the saw's applications and limitations as well as the specific potential hazards related to this tool.
2. **Guard against electrical shock** by preventing body contact with grounded surfaces such as pipes, radiators, ranges, refrigerator enclosures.
3. **Ground your saw.** Make sure that your saw is properly polarized with an approved ground connection.
4. **Keep the work area clean.** Cluttered work areas and work benches invite accidents. Do not leave tools or pieces of wood on the saw while it is in operation.
5. **Avoid dangerous environment.** Do not use power tools near gasoline or other flammable liquids, in damp or wet locations, or expose them to rain. Keep the work area well lit.
6. **Keep children and visitors away.** All visitors should wear safety glasses and be kept a safe distance from work area. Do not let visitors contact tool or extension cord while operating.
7. **Make workshop child-proof** with padlocks and master switches or by removing starter keys.
8. **Do not force the tool.** It will do the job better and more safely at the rate for which it was designed.
9. **Use the right tool for the job.** Do not force the tool or attachment to do a job it was not designed for. Use it only the way it was intended.
10. **Dress properly.** Do not wear loose clothing, gloves, neckties, rings, bracelets, or other jewelry. They can get caught and draw you into moving parts. Non-slip footwear is recommended. Also wear protective hair covering to contain long hair.
11. **Always wear safety glasses with side shields.** Everyday eyeglasses have only impact resistant lenses; they are not safety glasses.
12. **Protect your lungs.** Wear a dust mask to keep from inhaling fine particles.
13. **Protect your hearing.** Wear hearing protection during extended periods of operation.
14. **Do not abuse cord.** Never yank cord to disconnect it from receptacle. Keep cord from heat, oil, and sharp edges.
15. **Do not overreach.** Keep proper footing and balance at all times.
16. **Maintain tools with care.** Keep tools sharp and clean for better and safer performance. Follow instructions for lubricating and changing accessories.
17. **Disconnect all tools.** When not in use, before servicing, or when changing attachments, blades, bits, cutters, etc., all tools should be disconnected from power supply.
18. **Remove adjusting keys and wrenches.** Form the habit of checking to see that keys and adjusting wrenches are removed from tool before turning it on.
19. **Avoid accidental starting.** Make sure switch is off before plugging saw into power source.
20. **Use the proper extension cord.** Make sure your extension cord is in good condition. Use only a cord heavy enough to carry the current your product will draw. An undersized cord will cause a drop in line voltage resulting in loss of power and overheating. A wire gage size (A.W.G.) of at least **14** is recommended for an extension cord 25 feet or less in length. If in doubt, use the next heavier gauge. The smaller the gauge number, the heavier the cord.
21. **Keep blades clean, sharp and with sufficient set.** Sharp blades minimize stalling and kickback.
22. **Keep hands away from cutting area and the blade.** Do not reach underneath work or in blade cutting path for any reason. Always turn the power off.

### **WARNING:**

Blade coasts after being turned off.

23. **Never use this tool in an explosive atmosphere.** Normal sparking of the motor could ignite fumes.
24. **Inspect tool cords periodically.** If damaged, have repaired by a qualified service technician at an authorized Ryobi Service Center. The conductor with insulation having an outer surface that is green with or without yellow stripes is the equipment-grounding conductor. If repair or replacement of the electric cord or plug is necessary, do not connect the equipment-grounding conductor to a live terminal. Repair or replace a damaged or worn cord immediately. Stay constantly aware of cord location and keep it well away from the moving blade.
25. **Inspect extension cords periodically** and replace if damaged.
26. **Keep tool dry, clean, and free from oil and grease.** Always use a clean cloth when cleaning. Never use brake fluids, gasoline, petroleum-based products, or any solvents to clean tool.
27. **Stay alert and exercise control.** Watch what you are doing and use common sense. Do not operate tool when you are tired. Do not rush.
28. **Check damaged parts.** Before further use of the tool, check any damaged parts, including guards, for proper operation and performance. Check alignment of moving parts, binding of moving parts, breakage of parts, saw stability, mounting and any other conditions that may affect its operation. A damaged part must be properly repaired or replaced by a qualified service technician at an authorized Ryobi Service Center to avoid risk of personal injury.

# RULES FOR SAFE OPERATION

29. **Do not use tool if switch does not turn it on and off.** Have defective switches replaced by a qualified service technician at an authorized Ryobi Service Center.
30. **Guard against kickback.** Kickback can occur when the blade stalls rapidly, driving the work piece back toward the operator. It can pull your hand into the blade, resulting in serious personal injury. Stay out of the blade path and turn switch off immediately if blade binds or stalls.
31. **Use the rip fence.** Always use a fence or straight edge guide when ripping.
32. **Support large work pieces** to minimize risk of blade being pinched and creating a kickback.
33. **Before making a cut, be sure all adjustments are secure.**
34. **Use only correct blades.** Do not use blades with incorrect size holes. Never use blade washers or bolts that are defective or incorrect. The maximum blade capacity of your saw is 10 inches (254 mm).
35. **Use recommended accessories.** Using improper accessories may cause risk of injury.
36. **Never stand on tool.** Serious injury could occur if the tool is tipped or if the blade is unintentionally contacted.
37. **Use the right direction of feed.** Feed work into a blade or cutter against the direction of rotation of the blade or cutter only.
38. **Never leave tool running unattended.** Turn the power off. Do not leave tool until it comes to a complete stop.
39. **Avoid cutting nails.** Inspect for and remove all nails from lumber before cutting.
40. **Never touch blade** or other moving parts during use.
41. **Never start tool when any rotating component is in contact with the workpiece.**
42. **Do not operate this tool while under the influence of drugs, alcohol, or any medication.**
43. **Ground all tools.** If this tool is equipped with a 3-prong plug, it should be plugged into a 3-hole electrical receptacle.
44. **Save these instructions.** Refer to them frequently and use to instruct other users. If you loan someone this tool, loan them these instructions also.

## CAUTION:

When servicing, use only identical Ryobi replacement parts. Use of any other parts may create a hazard or cause product damage.

## WARNING:

Remove all fences and attachments before transporting saw. Failure to do so can result in an accident causing possible serious personal injury.

## WARNING:

Some dust created by power sanding, sawing, grinding, drilling, and other construction activities contains chemicals known to cause cancer, birth defects or other reproductive harm. Some examples of these chemicals are:

- lead from lead-based paints,
- crystalline silica from bricks and cement and other masonry products, and
- arsenic and chromium from chemically-treated lumber.

Your risk from these exposures varies, depending on how often you do this type of work. To reduce your exposure to these chemicals: work in a well ventilated area, and work with approved safety equipment, such as those dust masks that are specially designed to filter out microscopic particles.

# SPECIFIC SAFETY RULES FOR THE BTS10 TABLE SAW

- **Firmly bolt your saw to a workbench or table.** The most comfortable height is approximately 39" (1 m), or hip height.
- **Always secure work** firmly against rip fence or miter gauge.
- **Always use blade guard, riving knife, and anti-kickback pawls** on all "through-sawing" operations. Through-sawing operations are those in which the blade cuts completely through the workpiece as in ripping or cross-cutting. Keep the blade guard down, the anti-kickback pawls down, and the riving knife in place over the blade.
- **Secure work.** Use clamps or a vise to hold work when practical. It's safer than using your hand and frees both hands to operate tool.
- **Always use a push stick for ripping narrow stock.** A push stick is a device used to push a workpiece through the blade instead of using your hands. Size and shape can vary but the push stick must always be narrower than the workpiece to prevent the push stick from contacting the saw blade. When ripping narrow stock, always use a push stick so your hand does not come close to the saw blade. Use a push block or featherboard for non-through cuts.

# SPECIFIC SAFETY RULES FOR THE BTS10 TABLE SAW

- **Never perform any operation freehand**, which means using only your hands to support or guide the workpiece. Always use either the rip fence or the miter guide to position and guide the work.
- **Never stand or have any part of your body in line with the path of the saw blade.**
- **Never** reach behind, over, or within three inches of the blade with either hand for any reason.
- **Move the rip fence** out of the way when cross-cutting.
- **Never use the rip fence as a cut-off gauge** when cross-cutting.
- **Never attempt to free a stalled saw blade** without first turning the saw off and disconnecting the saw from the power source.
- **Use a support for the sides and back of the saw table when sawing wide or long workpieces.** To prevent tipping, use a sturdy "outrigger" support if a table extension is more than 24 inches long and is attached to the saw.
- **Avoid kickbacks** (work thrown back toward you) by:
  - Keeping the blade sharp.
  - Keeping rip fence parallel to the saw blade.
  - Keeping riving knife, anti-kickback pawls, and blade guard in place and operating.
  - Not releasing the work before it is pushed all the way past the saw blade using a push stick.
  - Not ripping work that is twisted or warped or does not have a straight edge to guide along the fence.
- **Avoid awkward operations and hand positions** where a sudden slip could cause your hand to move into the blade.
- **Check with a qualified electrician** if grounding instructions are not completely understood or if in doubt as to whether the tool is properly grounded.
- **Use only correct electrical devices:** 3-wire extension cords that have 3-prong grounding plugs and 3-pole receptacles that accept the tool's plug.
- **Do not modify the plug provided.** If it will not fit the outlet, have the proper outlet installed by a qualified electrician.
- **Use only recommended accessories listed in this manual.** Blades must be 10" (254 mm) in diameter, rated for at least 4,800 rpm or higher, with 5/8" (16 mm) arbor holes. Use of accessories that are not listed may cause the risk of personal injury. Instructions for the safe use of accessories are included with the accessory.
- **Double check all setups.** Make sure blade is tight and not making contact with saw or workpiece before connecting to power supply.
- **Make sure the work area has ample lighting** to see the work and that no obstructions will interfere with safe operation before performing any work using this tool.
- **Always turn off saw before disconnecting it,** to avoid accidental starting when reconnecting to power supply. Never leave the table saw unattended while connected to a power source.
- **Save these instructions.** Refer to them frequently and use to instruct other users. If you loan someone this tool, loan them these instructions also.

## GLOSSARY OF WOODWORKING TERMS

### Anti-Kickback Pawls

Device which, when properly installed and maintained, is designed to stop the workpiece from being kicked back toward the front of the saw during a ripping operation.

### Arbor

The shaft on which a blade or cutting tool is mounted.

### Bevel Cut

A cutting operation made with an angled blade.

### Compound Miter Cut

A single cut made with both a miter angle and a bevel angle.

### Cross Cut

A cut or shaping operation made across the grain of the workpiece.

### Cut-off Stock

The unused material that remains after a cutting operation.

### Dado

A non-through cut which produces a square sided notch or trough in the workpiece.

### Featherboard

A device used to help control the workpiece by guiding it securely against the table or fence during any rip cut operation.

### Freehand

Performing a cut without using a fence, miter gauge, fixture, hold down clamp, or other proper device to keep the workpiece from twisting during the cut.

### Gullets

The valleys or notches between the teeth in a saw blade.

### Gum

A sticky, sap-based residue from wood products.

# GLOSSARY OF WOODWORKING TERMS

- Heel**  
Misalignment of the blade.
- Kerf**  
The amount of material removed by the blade in a through-cut, or the slot produced by the blade in non-through or partial cut.
- Kickback**  
An uncontrolled grabbing or throwing of the workpiece back toward the front of the saw. Associated with the workpiece closing the kerf and pinching the blade or otherwise placing tension on the blade.
- Leading End**  
The end of the workpiece which, during a rip type operation, is pushed into the cutting tool first.
- Miter Cut**  
A cutting operation made with the wood at any angle other than 90° to the blade.
- Molding**  
A cut which produces a special shape in the workpiece, used for joining or decoration.
- Non-Through Cut**  
Any cutting operation where the blade does not extend completely through the thickness of the workpiece.
- Push Block**  
A device used to feed the workpiece through the saw, except during narrow rip type operations where a push stick should be used. It also helps keep the operator's hands well away from the blade.
- Push Stick**  
A device used to feed the workpiece through the saw to help keep the operator's hands well away from the blade.
- Rabbet**  
A notch in the edge of the workpiece.
- Resin**  
A sticky, sap-based substance that has hardened.
- Rip Cut**  
A cutting or shaping operation made along the length or grain of the workpiece.
- Rip Fence**  
Adjustable guide used in ripping cuts to keep the workpiece parallel to the saw blade.
- Riving Knife**  
Also known as a separator or spreader. A metal piece slightly thinner than the saw blade which helps keep the kerf open during cutting and prevents kickbacks.
- RPM**  
Revolutions per Minute. The number of turns completed by a spinning object in one minute. Used to measure the speed of the blade.
- Saw Blade Path**  
The area over, under, behind, or in front of the blade. As it applies to the workpiece, that area which will be, or has been, cut by the blade.
- Set**  
The distance that the tip of the saw blade tooth is bent (or set) outward from the face of the blade.
- Throat Plate**  
That part of the table surface through which the blade protrudes. Removal of the throat plate allows access to the blade arbor.
- Throw-Back**  
Throwing of a workpiece in a manner similar to a kickback. Usually associated with a cause other than the kerf closing, such as a workpiece being dropped onto the blade or being placed inadvertently in contact with the blade.
- Through Sawing**  
Any cutting operation where the blade extends completely through the thickness of the workpiece.
- Trailing End**  
The end of the workpiece last cut by the blade in a ripping operation.
- Workpiece**  
The piece of wood on which the cutting operation is being performed.

# UNPACKING YOUR TABLE SAW AND CHECKING CONTENTS

Your Model BTS10 Table Saw is shipped complete in one carton and includes rip fence, miter gauge, blade guard, accessory storage brackets, wrenches, Operator's Manual, and warranty information.

When you get your new table saw home, unpack the box to make sure all information and accessories are included. Separate all loose parts and compare with the illustration below to make sure all loose items are accounted for. Do not discard any packing material until you are sure you have everything or have checked all packaging for any missing parts.

If any parts are missing or damaged, contact 1-800-525-2579.

## **⚠ WARNING:**

To avoid risk of serious personal injury, do not attempt to assemble the table saw, plug in the power cord, or turn the power switch on until all damaged or missing parts are obtained and properly installed.

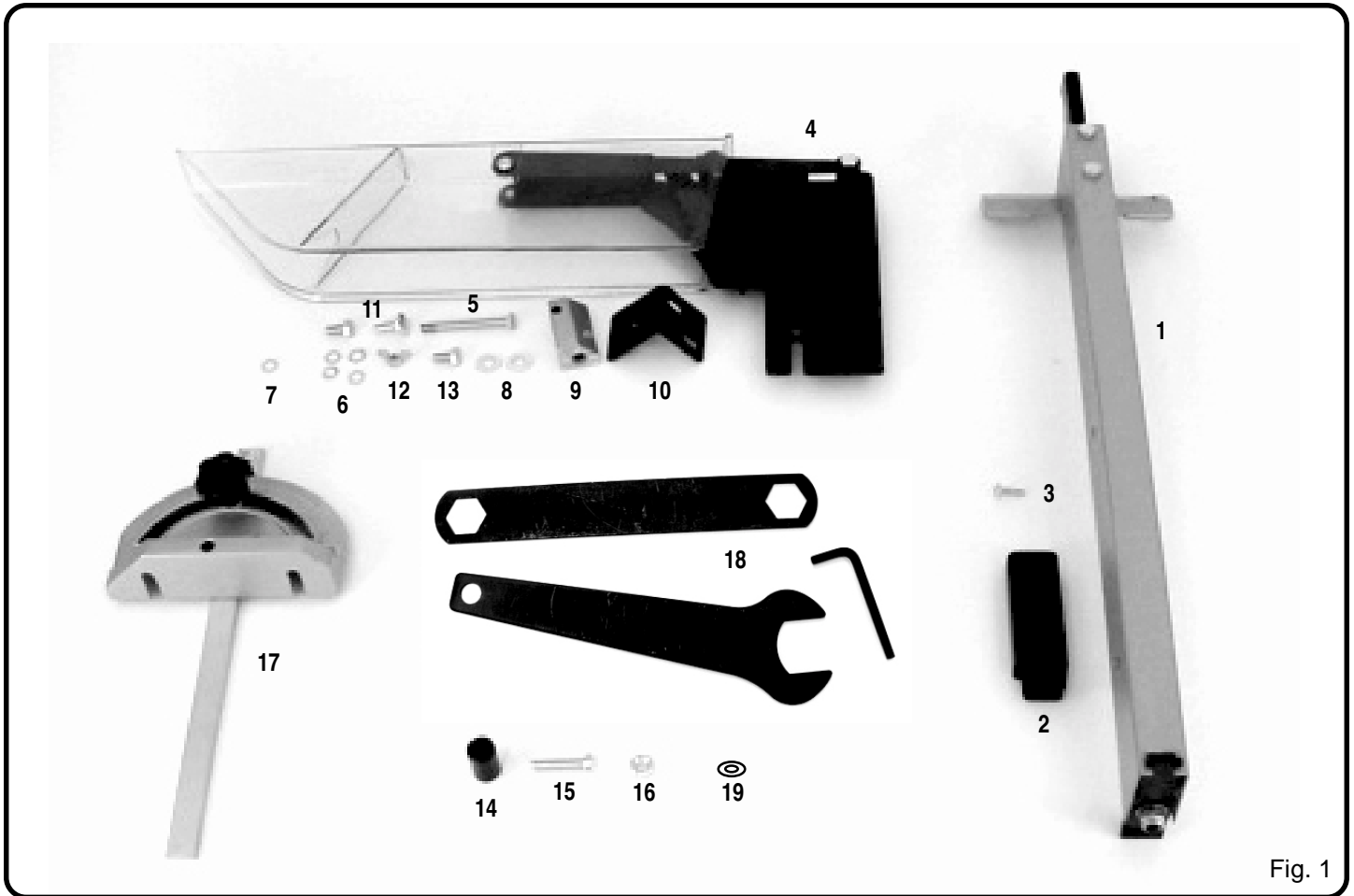

Fig. 1

## List of Loose Parts

Key #	Description	Quantity	Key #	Description	Quantity
1	Rip Fence .....	1	11	1/4-20 x 1/2" Hex Head Bolt .....	2
2	Rip Fence Lock Down Handle .....	1	12	M6 Wing Nut .....	1
3	M4 x 15 mm Tapping Screw .....	1	13	M6 x 19 mm Carriage Bolt .....	1
4	Blade Guard/Riving Knife Assembly .....	1	14	Blade Control Handle .....	1
5	1/4-20 x 2-1/4" Socket Head Bolt .....	1	15	1/4-20 x 2-7/16" Shoulder Bolt .....	1
6	1/4" External Tooth Lock Washers .....	4	16	1/4-20 Lock Nut .....	1
7	1/4" Internal Tooth Lock washer .....	1	17	Miter Gauge .....	1
8	1/4" Flat Washer .....	2	18	Wrenches .....	2
9	Blade Guard Mounting Bracket .....	1	19	1/4" Flat Washer .....	1
10	Blade Guard Support Bracket.....	1	20	Operator's Manual (Not Shown) .....	1



# FEATURES

## Know Your Table Saw

Your saw is designed to perform as a versatile, accurate, precision wood cutting tool that is easy to operate. It is equipped with the following features for convenience, ease of use, and high quality performance:

- Combination saw blade.
- Bevel indicator to set the exact angle of the blade, with locking lever.
- Adjustable miter gauge.
- Adjustable rip fence with scale indicator.
- Riving knife and blade guard with anti-kickback pawls.
- Front and rear guide rails with an easy to read scale on front rail.

- Blade height control handle to set depth of cut.
- Rack and pinion bevel control.
- Overload reset button.
- On/off switch key.

### **⚠ WARNING:**

Before attempting to use your new Ryobi table saw, familiarize yourself with all the safety requirements listed in this Operator's Manual and the operating features shown in Figure 2.

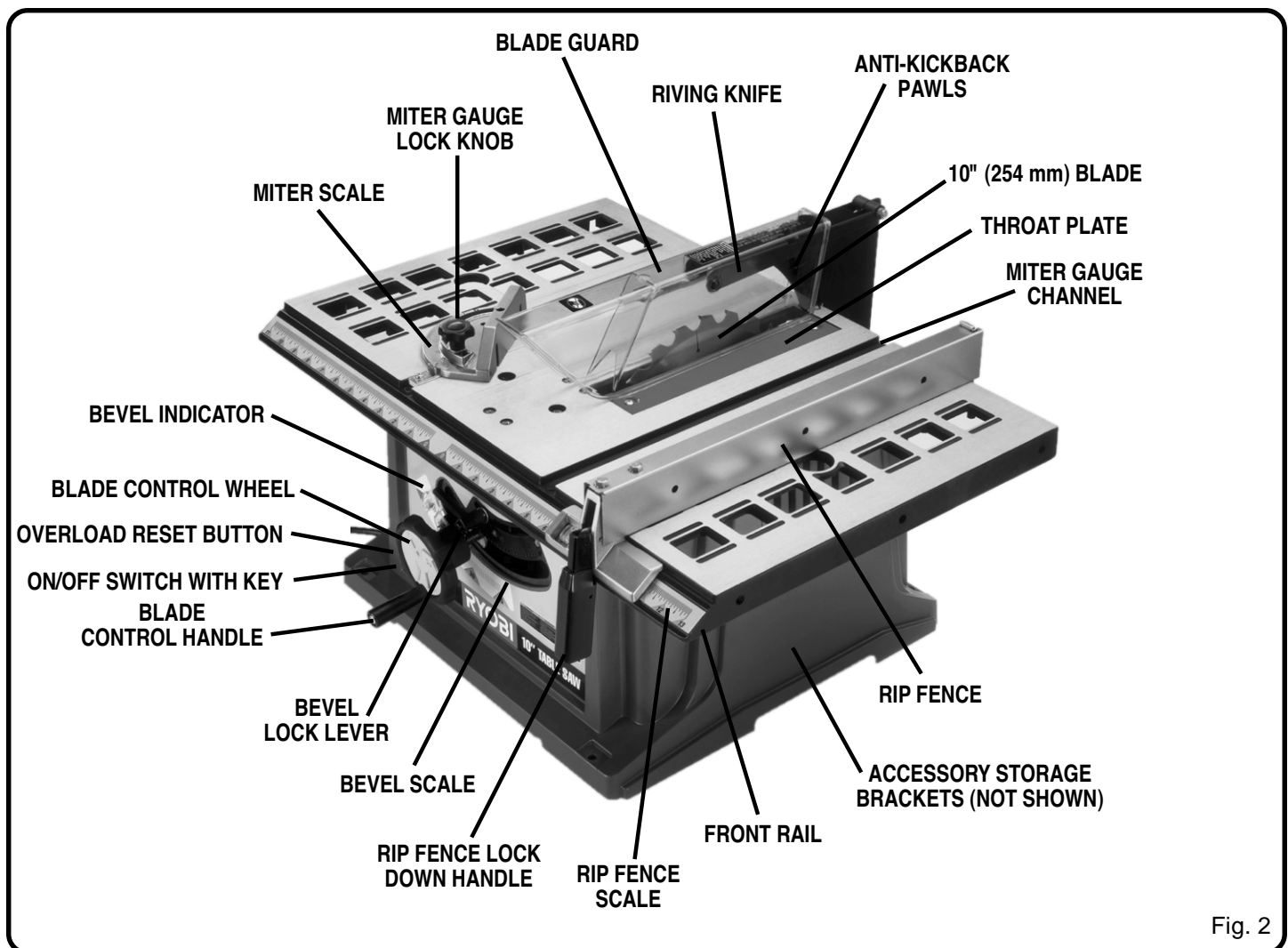

Fig. 2

# ASSEMBLY

## **⚠ WARNING:**

Do not connect to power supply until assembly is complete. Failure to comply could result in accidental starting and possible serious personal injury.

## TOOLS NEEDED

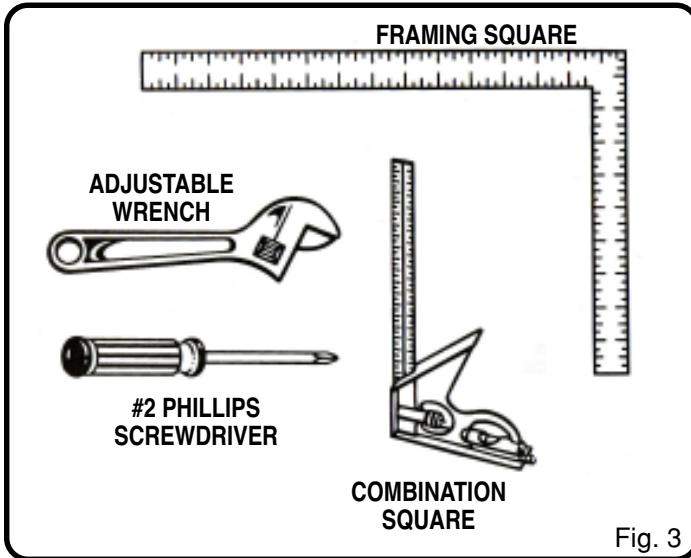

## ASSEMBLING THE BLADE CONTROL HANDLE

Feed the 1/4-20 x 2-7/16" shoulder bolt through the front of the handle so that the screw head is recessed in the handle.

Place the M6 wing nut in the nut pocket in the rear of the control wheel, behind the pre-drilled hole. Place your finger over the nut to hold it in place.

Insert the screw through the hole in the front of the control wheel. Holding the nut and screw in place, tighten with a Phillips screwdriver.

## ATTACHING BLADE GUARD ASSEMBLY

Loosen bevel control by turning bevel lock lever all the way to the left. If it needs to be further loosened, pull spring-loaded bevel lock lever out and rotate it back to the right. Release bevel lock lever and allow it to seat in its original position. Turn it to the left again until loose.

Push the handle on the control wheel in toward the saw and rotate clockwise until the blade is set to 90° as indicated on the bevel indicator.

Tighten bevel control by turning bevel lock lever to the right. If it needs to be tightened more, pull the spring-loaded bevel lock lever out and rotate it to the left. Then release bevel lock lever and allow it to return to its original position. Rotate to the right again. Repeat this process until bevel lock lever is securely tightened.

Fasten the support bracket to the mounting bracket as shown in Figure 4 using the two 1/2" hex head bolts and two 1/4" external tooth lock washers. Do not tighten bolts.

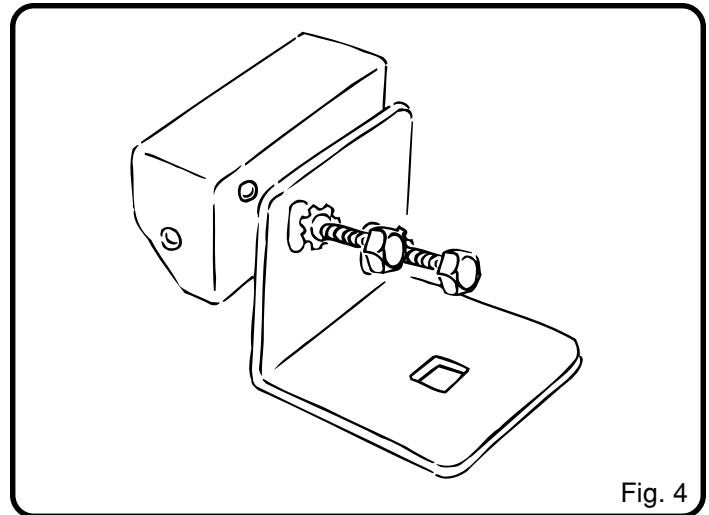

Assemble the internal tooth lock washer, flat washer, and external tooth lock washer onto the 1/4-20 x 2-1/4" socket head bolt. Then feed the assembled bolt through the hole in the mounting bracket and into the exposed end of the threaded rod at the back of the saw as shown in Figure 5. Securely tighten with hex wrench provided.

**NOTE:** The exposed end of the threaded rod on the back of the saw inserts into the recessed end of the mounting bracket.

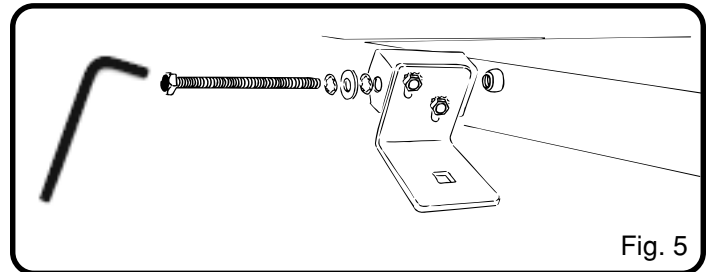

## **⚠ WARNING:**

Confirm blade guard assembly is properly aligned and all mounting hardware is attached and securely tightened before each use of the saw. Failure to comply can result in serious personal injury.

Position the blade guard on the support bracket so that the top circular tab fits in the upper hole in the blade guard assembly and the lower tab is in the slot. See Figure 6.

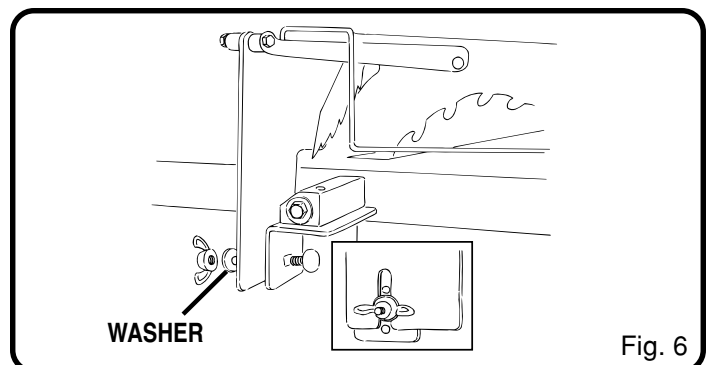

# ASSEMBLY

Attach blade guard assembly to support bracket with M6 x 19 mm carriage bolt. Secure with a 1/4" flat washer, external tooth lock washer and wing nut.

**NOTE:** Before tightening wing nut, make sure there is at least 1/8" (3 mm) between the end of the table and blade guard assembly. Also check to make sure that the two circular tabs are still engaged inside the upper hole and slotted opening.

Raise the saw blade by turning the control wheel handle counterclockwise.

Raise the transparent blade guard, then use a straight edge to make sure that the blade guard assembly is aligned with the saw blade.

If the blade guard assembly is not aligned with the blade, loosen the 1/2" hex head bolts and/or the 2-1/4" socket head bolt and reposition the blade guard assembly so that it is aligned with the blade. Once aligned, securely tighten all bolts.

## **WARNING:**

Failure to confirm blade guard assembly is properly aligned with the blade could cause the workpiece to jam while sawing, causing kickback and injury.

## **INSTALL MITER GAUGE**

To install the pre-assembled miter gauge, simply slide the long end of the miter gauge into the miter gauge channel as shown in Figure 7.

## **INSTALLING THE RIP FENCE LOCK DOWN HANDLE**

Locate the lock down handle and an M4 x 15 mm tapping screw.

Slide the handle over the exposed end of the rip fence. Make sure the handle is inserted as far as it can go. The hole in the metal rip fence should line up with the recessed hole in the handle. Secure handle using the M4 x 15 mm tapping screw.

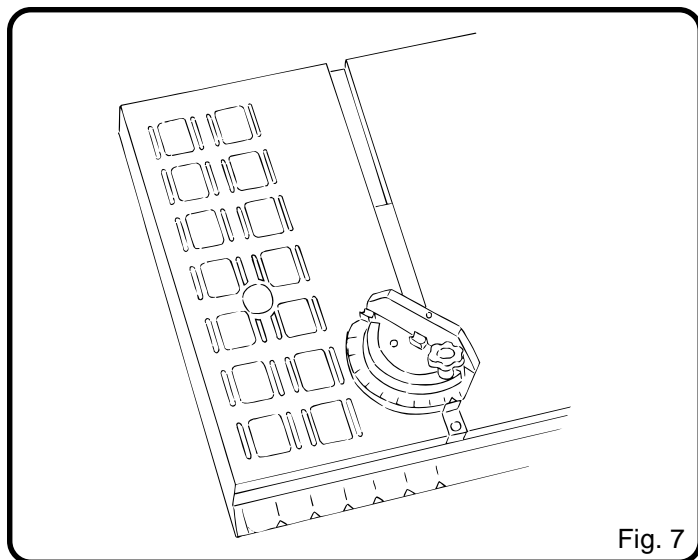

## **INSTALLING THE RIP FENCE**

The rip fence attaches to the rear and front rails by two flanges on either end of the fence. When the lock down handle is in the **Up** position (parallel to the fence), the flanges are relaxed, allowing you to reposition the rip fence. When the lock down handle is in the **Down** position (perpendicular to the fence), the flanges are drawn together and the rail is held in place.

To install the rip fence, place the end furthest from the handle so that the flange is over the rear edge of the table. Then lower the end closest to the lock down handle over the front rail.

**NOTE:** For accurate alignment, make sure that the front block is flush against the front rail.

Push the lock down handle down to fix the rail in place.

# GENERAL INFORMATION

## **⚠ WARNING:**

Your table saw has a precision built electric motor. It should only be connected to a power supply that is 120 volts, 60 Hz, AC only (normal household current). Do not operate this tool on direct current (DC). A substantial voltage drop will cause a loss of power and the motor will overheat. If your tool does not operate when plugged into an outlet, double check the power supply.

## **ON/OFF SWITCH KEY**

Your Ryobi table saw is equipped with an on/off switch key that, if removed, prevents the saw from being turned on. The key must be in place to turn the saw on. If the key is removed during operation, the saw may be turned off but may not be turned on again until the key is replaced. See *Figure 8*.

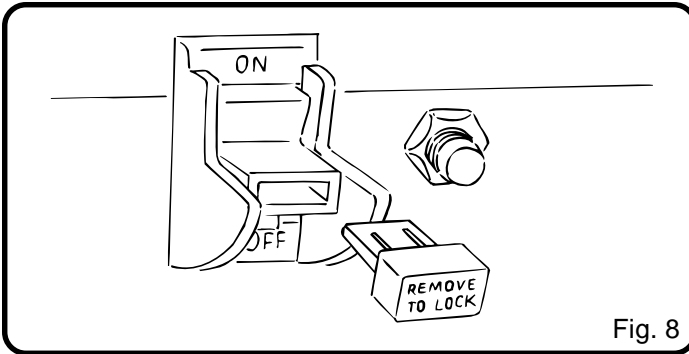

Fig. 8

## **GROUNDING**

In the event of a malfunction or breakdown, grounding provides a path of least resistance for electric current to reduce the risk of electric shock. This tool is equipped with an electric cord having an equipment-grounding conductor and a grounding plug. The plug must be plugged into a matching outlet that is properly installed and grounded in accordance with all local codes and ordinances.

Do not modify the plug provided. If it will not fit the outlet, have the proper outlet installed by a qualified electrician. Improper connection of the equipment-grounding conductor can result in electrical shock. The conductor having an outer surface that is green with or without yellow stripes is the equipment-grounding conductor. If repair or replacement of the electric cord or plug is necessary, do not connect the equipment conductor to a live terminal.

## **⚠ WARNING:**

If an extension cord is used, make sure it is a grounded/3-prong plug and is adequate to prevent excessive voltage loss. See Extension Cord Caution on back page.

Check with a qualified electrician or service personnel if the grounding instructions are not completely understood, or if in doubt as to whether the tool is properly grounded.

Repair or replace a damaged or worn cord immediately.

This tool is intended for use on a circuit that has an outlet like the one shown in *Figure 9*. It also has a grounding pin like the one shown.

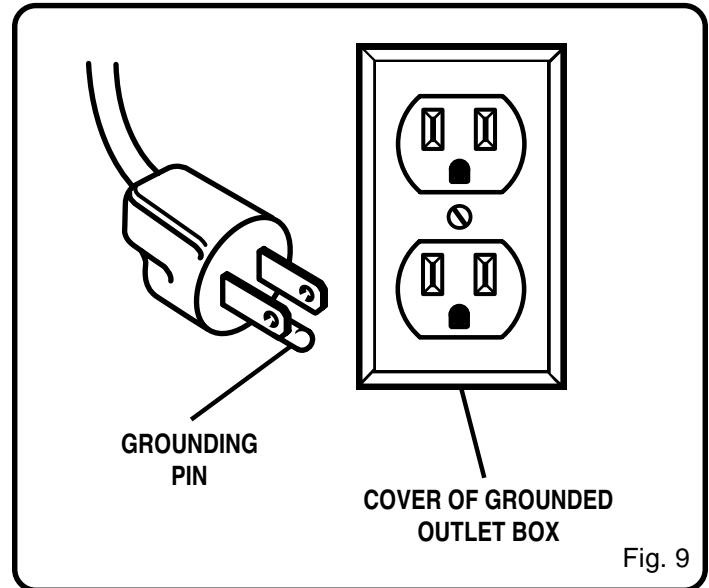

## **OVERLOAD RESET BUTTON**

Your Ryobi table saw features an overload reset button. In the event that your saw turns off during operation, turn the saw off and allow the motor to cool down for approximately 3 minutes. Push the reset button and attempt to turn the saw on again. If the saw does not turn on, turn the switch off and check all cords for proper connection and retry. If it still does not turn on, contact your authorized Ryobi Service Center. If it turns on and then cuts off while you are working, you may be trying to feed the workpiece too quickly or may be trying to operate on a circuit providing insufficient voltage.

## **SPEED AND WIRING**

The no-load speed of your saw is approximately 4,800 rpm. This speed is not constant and decreases under a load or with lower voltage. A line intended only for lights cannot properly carry a power tool motor. Wire that is heavy enough for a short distance will be too light for a greater distance. A line that can support one power tool may not be able to support two or three.

# ADJUSTMENTS

## CALIBRATING AND ADJUSTING YOUR SAW

### **⚠ WARNING:**

Before performing any adjustments or calibrations, make sure the table saw is unplugged from the power supply and the switch is in the "OFF" position. Failure to heed this warning can result in serious personal injury.

Before operating your saw, check for proper alignment of the blade and riving knife. You should also check that the 90° and 45° positive stops are accurate. These should be done prior to each use.

### **CHECKING/ADJUSTING SAW BLADE AND BLADE GUARD ASSEMBLY ALIGNMENT**

To check the alignment of the saw blade and blade guard assembly, raise the blade guard. Place a straight edge flush against the face of the saw blade. The straight edge should line up flush with the blade guard assembly. Lower the blade guard to its original position.

If the blade guard assembly and blade are not in alignment, adjust the blade guard assembly by doing the following:

1. Raise the blade guard.
2. To adjust the horizontal alignment, loosen the two 1/2" hex head bolts holding the mounting bracket to the support bracket. *See Figure 10.* Reposition the blade guard assembly so that the blade guard assembly lines up with the saw blade. Securely tighten bolts.

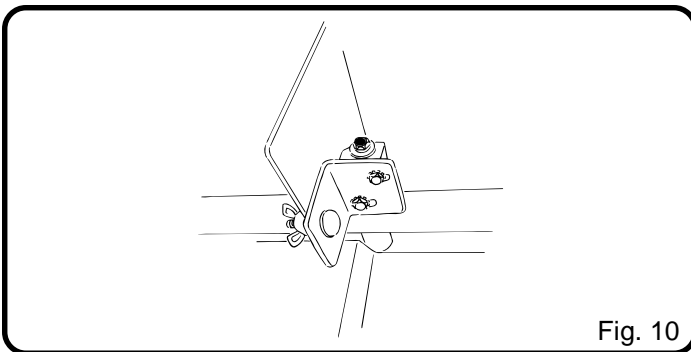

3. To adjust the vertical alignment, loosen the 2-1/4" socket head bolt holding the mounting bracket to the back of the saw. Use a framing square to make sure the blade guard assembly is perpendicular to the table surface. Securely tighten bolt.
4. Return the blade guard to the lowered position.

### **⚠ WARNING:**

If the blade guard/riving knife is out of alignment with the saw blade, adjust the alignment of the blade guard/riving knife assembly and securely tighten all mounting hardware. Do not attempt to adjust the alignment of the saw blade. Failure to heed this warning can result in serious personal injury.

## BEVEL ADJUSTMENTS

Your Ryobi Table Saw has a rack and pinion bevel control that allows you to make angled cuts from 90° to 45°.

**NOTE:** A 90° cut has a 0° bevel and a 45° cut has a 45° bevel.

To change the bevel angle follow these steps.

1. Disconnect the saw from the power supply.
2. Loosen bevel control by turning bevel lock lever all the way to the left. If it needs to be further loosened, pull spring-loaded bevel lock lever out and rotate it back to the right. Release bevel lock lever and allow it to seat in its original position. Turn it to the left again until loose.
3. Adjust the bevel angle by pushing the wheel in toward the saw then turning it. Turning the wheel counterclockwise increases the angle of the blade, bringing it closer to 45°. Turning it clockwise decreases the angle, bringing the blade closer to 90°.
4. Tighten bevel control by turning bevel lock lever to the right. If it needs to be tightened more, pull the spring-loaded bevel lock lever out and rotate it to the left. Then release bevel lock lever and allow it to return to its original position. Rotate to the right again. Repeat this process until bevel lock lever is securely tightened.

### **CHECKING 90° AND 45° POSITIVE STOPS**

To check the 90° positive stop, use a framing square. First, make sure the bevel indicator is as far to the left as possible. This will engage the 90° positive stop. Next, place the square with one side flush with the table surface. The other side should line up flush with the blade.

To check the 45° positive stop, use the angled corner of the combination square. Engage the bevel control and tilt the blade all the way to the right to engage the 45° positive stop. Place the square on the table surface with the angled corner against the blade. The blade and table should both be flush with the square.

If the positive stops need adjusting, proceed as follows.

### **TO ADJUST THE 90° POSITIVE STOP**

Make sure the saw is unplugged from the power source. Raise the blade to the maximum height by turning the blade control wheel counterclockwise. Loosen the bevel control by turning the bevel lock lever to the left.

Next, push the blade control wheel in toward the saw and rotate clockwise until it stops. Use the framing square to check the position of the blade.

**If the blade angle is less than 90°**, turn the 90° Positive Stop Adjustment Screw counterclockwise one turn. Push the blade control wheel in and rotate counterclockwise until it stops. Recheck the blade position. Continue this process until the blade is at 90°. Tighten the bevel control lever.

**If the blade angle is greater than 90°**, use the framing square to position the blade to 90°. Turn the 90° Positive Stop Adjustment Screw clockwise until it stops. Tighten the bevel control lever.

# ADJUSTMENTS

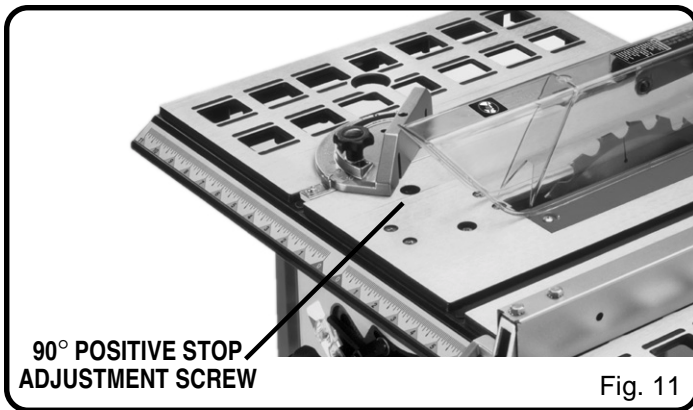

Reset the Bevel Indicator to 90° by loosening the screw holding the indicator. Line up the red line on the indicator with the 0° mark on the bevel scale.

## TO ADJUST THE 45° POSITIVE STOP

Make sure the saw is unplugged from the power source. Raise the blade to the maximum height by turning the blade control wheel counterclockwise. Turn the bevel lock lever to the left to loosen the bevel.

Next, push the blade control wheel in and rotate counterclockwise until it stops. Check the blade position using the angled corner of a combination square or triangle.

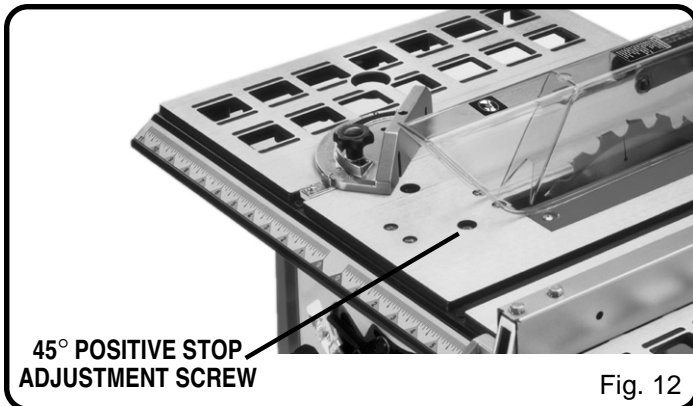

**If the blade angle is greater than 45°**, turn the 45° Positive Stop Adjustment Screw counterclockwise 1 turn and rotate the bevel control wheel counterclockwise until it stops. Recheck the blade position. Continue this process until the blade is at 45°. Tighten the bevel control lever.

**If the blade angle is less than 45°**, use the combination square or triangle to position the blade at 45°. Turn the 45° Positive Stop Adjustment Screw clockwise until it stops. Tighten the bevel control lever.

Reset the Bevel Indicator to 45° by loosening the screw holding the indicator. Line up the red line on the indicator with the 45° mark on the bevel scale.

## TO ADJUST THE BLADE HEIGHT

1. Disconnect saw from power supply.
2. Turn blade control wheel. Turning it clockwise lowers the blade. Turning it counterclockwise raises it.

3. For through-cuts, place the workpiece to be cut flush against the blade. Set the blade so that the tips of the uppermost tooth are about an 1/8" (3 mm) higher than the workpiece and the valley between the teeth (gullet) is lower than the workpiece as in Figure 13.

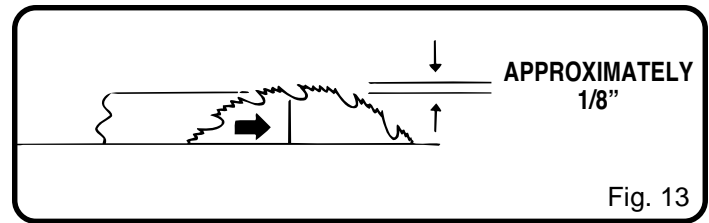

4. For non-through cuts, use a ruler or other graduated straight-edge to measure from the table surface to the tip of the uppermost tooth on the blade.

## TO ADJUST THE RIP FENCE

To reposition the rip fence, lift the lock down handle to the **Up** position (parallel to the fence). Use the indicator on the fence to slide the fence to the desired position. Make sure the front bar on the rip fence is flush against the front rail. Then move the lock down handle to the **Down** position (perpendicular to the fence).

## TO ADJUST TENSION ON THE RIP FENCE

To avoid risk of kickback and to ensure accuracy, the rip fence must be securely attached to the front rail and rear edge. If there is lateral play in the fence, tighten the adjustment nut at the back of the fence. If the rip fence lock down lever is too tight, loosen the adjustment nut.

### **⚠ WARNING:**

The rip fence must be positioned parallel to the miter gauge channel to prevent risk of kickback.

To ensure proper alignment, use a framing square to measure the distance from the front end of the rip fence to either of the miter gauge channels. Then measure from the rear end of the fence to the same miter gauge channel. If the two measurements are not the same, reposition the rear end of the fence and measure again.

## TO ADJUST THE MITER GAUGE

To adjust the miter gauge, simply loosen the lock knob and rotate the miter gauge to the desired position. Then tighten the lock knob.

**NOTE:** There are two miter gauge channels, one on either side of the blade. When making a 90° cross-cut, you can use either miter gauge channel. When making a beveled cross cut (the blade tilted in relation to the table) the miter gauge should be located in the slot on the right so that the blade is tilted away from the miter gauge and your hands.

# OPERATION

## MAKING CUTS

There are seven basic types of cuts:

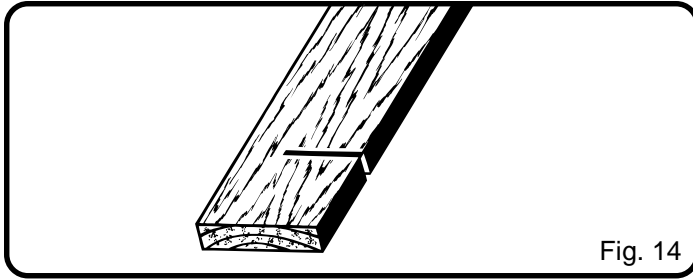

### Straight Cross Cut

Cut made across the grain.

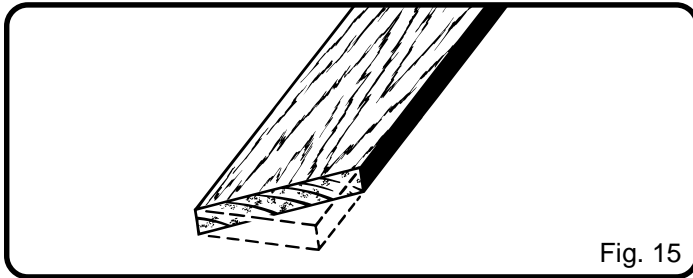

### Miter Cross Cut

Cut made with the workpiece at an angle (other than 90°) relative to the blade.

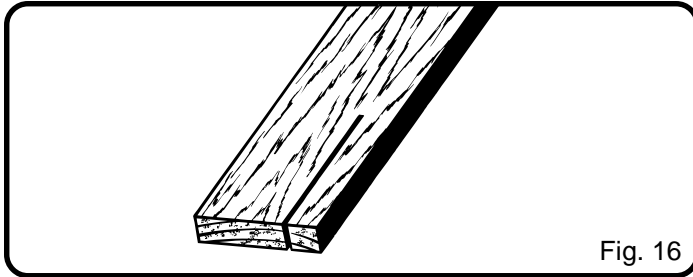

### Straight Rip Cut

Cut made with the grain.

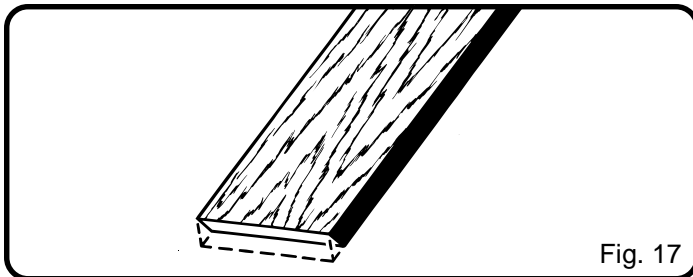

### Bevel Cross Cut

Cut made with the blade tilted relative to the table surface across the grain.

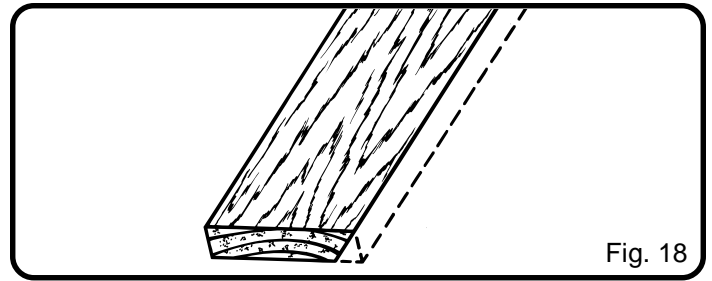

### Bevel Rip Cut

Cut made along the grain with the blade tilted.

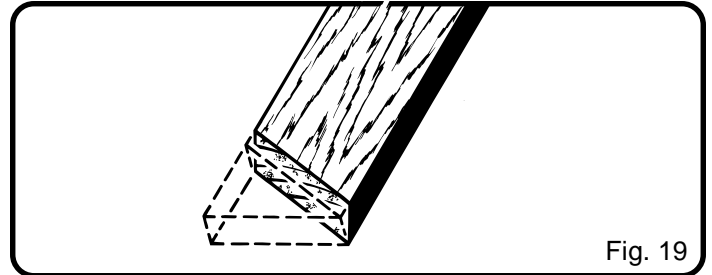

### Compound Miter Cross Cut

Cut made with an angled blade on wood that is angled to the blade.

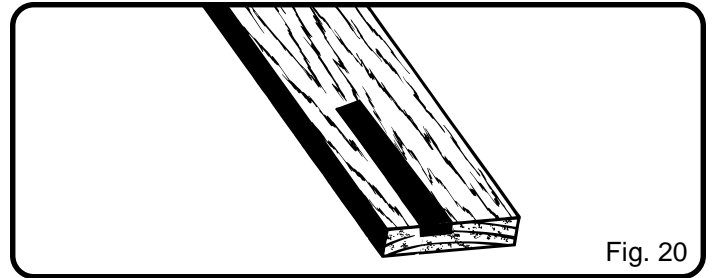

### Non-through Cut

A cut in which the blade does not cut through the entire thickness of the workpiece.

# OPERATION

This section deals with the proper procedures for making these seven basic cuts.

## CUTTING TIPS

- The kerf (the cut made by the blade in the wood) will be wider than the blade to prevent overheating or binding. Make allowances for the kerf when measuring wood.
- Make sure the kerf is made on the scrap side of the measuring line.
- Cut the wood with the finish side up.
- Knock out any loose knots with a hammer before making the cut.
- Always provide proper support for the wood as it comes out of the saw.

## TO MAKE A RIP CUT

It is recommended that you make a test cut on scrap wood first.

### **WARNING:**

Make sure the blade guard assembly is securely installed and working properly to avoid serious personal injury.

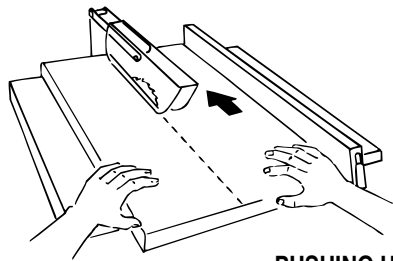

GUIDING HAND      PUSHING HAND  
PROPER FEEDING PROCEDURE FOR RIP CUTS

Fig. 21

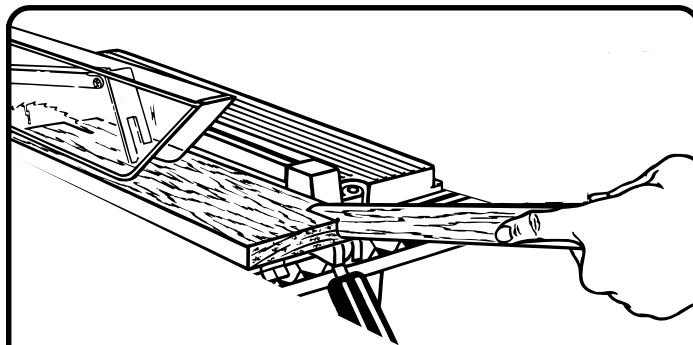

WHENEVER POSSIBLE USE PUSH BLOCKS OR  
PUSH STICKS TO FEED WORKPIECE INTO THE BLADE

Fig. 22

1. Removed the miter gauge by sliding it out of the channel.
2. Position the rip fence the desired distance from the blade, remembering to allow for the kerf, and lock down the handle.

3. If ripping a piece larger than 36" long, place a support the same height as the table surface behind the saw for the cut work.
4. Make sure that all loose items have been removed from the table surface and that the workpiece is not in contact with the blade.
5. Turn the On/Off switch to the **On** position.
6. Position the workpiece flat on the table with the edge flush against the rip fence. Let the blade build up to full speed before feeding the workpiece into the blade.
7. Using a push stick and/or push blocks, slowly feed the workpiece toward the blade. Stand slightly to the side of the wood as it contacts the blade to reduce the chance of injury should kickback occur.
8. Once the blade has made contact with the workpiece, use the hand closest to the rip fence to guide it. Make sure the edge of the workpiece remains in solid contact with both the rip fence and the surface of the table. If ripping a piece narrower than 4", use a push stick to move the piece through the cut and past the blade.
9. Continue to feed the workpiece into the blade until the cut has been completed.
10. Grasp the workpiece from the lead end (the end that was fed into the blade first) and carefully remove it from the table.
11. Turn the On/Off Switch to the **Off** position.
12. After the blade has stopped completely, remove the cut-off stock.

### **WARNING:**

To avoid serious personal injury, never push a small piece of wood into the blade with your hand, always use a push stick. The use of push blocks, push sticks, and featherboards are mandatory when making non-through cuts.

## TO MAKE A CROSS-CUT

It is recommended that you make a test cut on scrap wood first.

### **WARNING:**

Make sure the blade guard assembly is securely installed and working properly to avoid serious personal injury.

1. Remove the rip fence by lifting the lock down handle.
2. Loosen the lock knob on the miter gauge, set the miter gauge to 90° and tighten the lock knob.
3. Make sure that all loose items have been removed from the table surface and that the workpiece is not in contact with the blade.
4. Turn the On/Off Switch to the **On** position.



# OPERATION

5. Position the workpiece flat on the table with the edge flush against the miter gauge. Let the blade build up to full speed before feeding the workpiece into the blade.
6. Use two hands to slowly advance the workpiece and the miter gauge toward the blade. Use the hand furthest from the blade to keep the workpiece flush against the miter gauge. Use the other hand to push the miter gauge and workpiece toward the blade. Stand slightly to the side of the wood as it contacts the blade to reduce the chance of injury should kickback occur.
7. Continue to feed the workpiece into the blade until the cut has been completed.
8. Once the cut is complete, pull the workpiece away from the blade and back toward you.
9. Turn the On/Off Switch to the **Off** position.
10. After the blade has stopped completely, remove the cut-off stock.

## TO MAKE A MITER CROSS CUT

It is recommended that you make a test cut on scrap wood first.

### **WARNING:**

Make sure the blade guard assembly is securely installed and working properly to avoid serious personal injury.

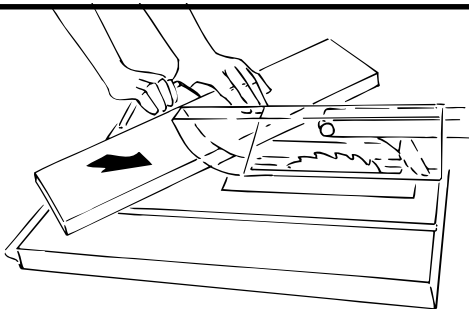

**PROPER FEEDING PROCEDURE FOR MITERED CROSS CUTS**

Fig. 23

1. Remove the rip fence by lifting the lock down handle.
2. Loosen the lock knob on the miter gauge, set the miter gauge to the desired angle and tighten the lock knob.
3. Make sure that all loose items have been removed from the table surface and that the workpiece is not in contact with the blade.
4. Turn the On/Off Switch to the **On** position.
5. Position the workpiece flat on the table with the edge flush against the miter gauge. Let the blade build up to full speed before feeding the workpiece into the blade.
6. Use two hands to slowly advance the workpiece and the miter gauge toward the blade. Use the hand furthest from the blade to keep the workpiece flush against the miter gauge. Use the other hand to push the miter gauge and

workpiece toward the blade. Stand slightly to the side of the wood as it contacts the blade to reduce the chance of injury should kickback occur.

7. Continue to feed the workpiece into the blade until the cut has been completed.
8. Once the cut is complete, pull the workpiece away from the blade and back toward you.
9. Turn the On/Off Switch to the **Off** position.
10. After the blade has stopped completely, remove the cut-off stock.

## TO MAKE A BEVEL CROSS CUT

It is recommended that you place the piece to be saved on the left side of the blade and that you make a test cut on scrap wood first.

### **WARNING:**

Make sure the blade guard assembly is securely installed and working properly to avoid serious personal injury.

1. Remove the rip fence by lifting the lock down handle.
2. Adjust the bevel angle to the desired setting. *See page 13.*
3. Set the blade to the correct depth. *See page 14.*
4. Loosen the lock knob on the miter gauge, set the miter gauge to 90° and tighten the lock knob.
5. Make sure that all loose items have been removed from the table surface and that the workpiece is not in contact with the blade.
6. Turn the On/Off Switch to the **On** position.
7. Position the workpiece flat on the table with the edge flush against the miter gauge. Let the blade build up to full speed before feeding the workpiece into the blade.
8. Use two hands to slowly advance the workpiece and the miter gauge toward the blade. Use the hand furthest from the blade to keep the workpiece flush against the miter gauge. Use the other hand to push the miter gauge and workpiece toward the blade. Stand slightly to the side of the wood as it contacts the blade to reduce the chance of injury should kickback occur.
9. Continue to feed the workpiece into the blade until the cut has been completed.
10. Once the cut is complete, pull the workpiece away from the blade and back toward you.
11. Turn the On/Off Switch to the **Off** position.
12. After the blade has stopped completely, remove the cut-off stock.

# OPERATION

## TO MAKE A BEVEL RIP CUT

It is recommended that you place the piece to be saved on the right side of the blade and that you make a test cut on scrap wood first.

### **WARNING:**

The rip fence must be on the right side of the blade to avoid trapping the wood and causing kickback.

### **WARNING:**

Make sure the blade guard assembly is securely installed and working properly to avoid serious personal injury.

1. Remove the miter gauge by sliding it out of the channel.
2. Position the rip fence the desired distance from the right side of the blade and lock down the handle.
3. Adjust the bevel angle to the desired setting. *See page 13.*
4. Set the blade to the correct depth. *See page 14.*
5. If ripping a piece larger than 36" long, place a support the same height as the table surface behind the saw for the cut work.
6. Make sure that all loose items have been removed from the table surface and that the workpiece is not in contact with the blade.
7. Turn the On/Off switch to the **On** position.
8. Position the workpiece flat on the table with the edge flush against the rip fence. Let the blade build up to full speed before feeding the workpiece into the blade.
9. Using a push stick and/or push blocks, slowly feed the workpiece toward the blade. Stand slightly to the side of the wood as it contacts the blade to reduce the chance of injury should kickback occur.
10. Once the blade has made contact with the workpiece, use the hand closest to the rip fence to guide it. Make sure the edge of the workpiece remains in solid contact with both the rip fence and the surface of the table. If ripping a piece narrower than 4", use a push stick to move the piece through the cut and past the blade.
11. Continue to feed the workpiece into the blade until the cut has been completed.
12. Grasp the workpiece from the lead end (the end that was fed into the blade first) and carefully remove it from the table.
13. Turn the On/Off Switch to the **Off** position.
14. After the blade has stopped completely, remove the cut-off stock.

## TO MAKE A COMPOUND MITER CROSS CUT

It is recommended that you place the piece to be saved on the left side of the blade and that you make a test cut on scrap wood first.

### **WARNING:**

Make sure the blade guard assembly is securely installed and working properly to avoid serious personal injury.

1. Remove the rip fence by lifting the lock down handle.
2. Adjust the bevel angle to the desired setting. *See page 13.*
3. Set the blade to the correct depth. *See page 14.*
4. Loosen the lock knob on the miter gauge, set the miter gauge to the desired angle and tighten lock knob.
5. Make sure that all loose items have been removed from the table surface and that the workpiece is not in contact with the blade.
6. Turn the On/Off Switch to the **On** position.
7. Position the workpiece flat on the table with the edge flush against the miter gauge. Let the blade build up to full speed before feeding the workpiece into the blade.
8. Use two hands to slowly advance the workpiece and the miter gauge toward the blade. Use the hand furthest from the blade to keep the workpiece flush against the miter gauge. Use the other hand to push the miter gauge and workpiece toward the blade. Stand slightly to the side of the wood as it contacts the blade to reduce the chance of injury should kickback occur.
9. Continue to feed the workpiece into the blade until the cut has been completed.
10. Once the cut is complete, pull the workpiece away from the blade and back toward you.
11. Turn the On/Off Switch to the **Off** position.
12. After the blade has stopped completely, remove the cut-off stock.

## TO MAKE NON-THROUGH CUTS

Non-through cuts can be made with the grain (ripping) or across the grain (cross cut). Non-through cuts are essential in cutting grooves, rabbets, and dadoes. This is the only type of cut made with the blade guard assembly removed. You must make sure the entire blade guard assembly is re-installed properly upon completion of this type of cut.

In addition to this section, make sure to read the section on the specific type of non-through cut being made. For example, if your non-through cut is a cross cut, read and understand the section on cross cuts thoroughly before proceeding.

### **WARNING:**

Unplug the saw to avoid serious personal injury.

# OPERATION

1. Remove the wing nut and carriage bolt holding the blade guard assembly to the blade guard support bracket. See *Figure 24*. Remove the blade guard assembly.
2. Lower the blade to the correct height by turning the blade control handle counterclockwise.
3. Always use push blocks, push sticks and featherboards when making non-through cuts to avoid the risk of serious personal injury. See *Figure 25*.

## **⚠ WARNING:**

Carefully check all set ups and rotate the blade one full revolution to assure proper clearance before connecting saw to power source. Failure to comply can result in serious personal injury.

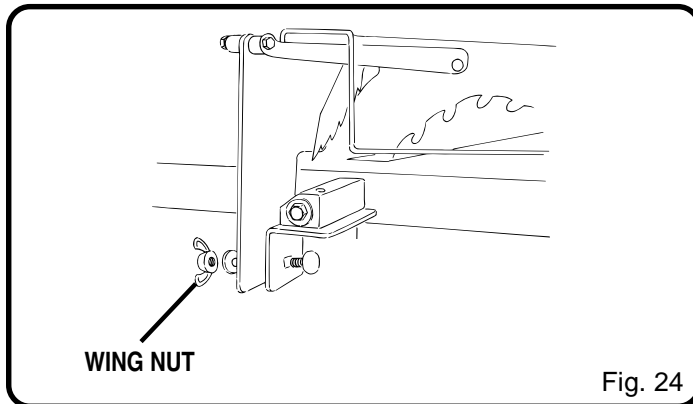

## **⚠ WARNING:**

Never feed wood through with your hands when making non-through cuts such as rabbets or dadoes. Always use push sticks and push blocks. Failure to heed this warning can result in serious personal injury.

4. When the cut is complete, unplug the saw and raise the blade.
5. Reinstall the blade guard assembly, attaching the blade guard assembly to the support bracket using the carriage bolt and wing nut. Make sure the circular tabs on the support bracket are aligned with the hole and slot on the blade guard assembly. Tighten the wing nut. Securely tighten all mounting hardware.
6. Check riving knife alignment to blade face and adjust if necessary. See *page 13*.

## **⚠ WARNING:**

Confirm blade guard assembly is properly aligned and all mounting hardware is attached and securely tightened before each use of the saw. Failure to comply can result in serious personal injury.

## **PUSH STICKS**

A push stick is a device used to safely push a workpiece through the blade instead of using your hands. Push sticks in various sizes and shapes can be made from scrap wood. The stick must always be narrower than the workpiece. If it is too wide, it may jam on the rip fence or blade. When ripping narrow stock, always use a push stick so your hand does not come close to the saw blade.

**NOTE:** Push blocks and featherboards should always be used when making non-through cuts.

A simple push stick design is shown in *Figure 25*. Remember that the push stick must always be narrower than your workpiece. You may want to make several push sticks of varying widths.

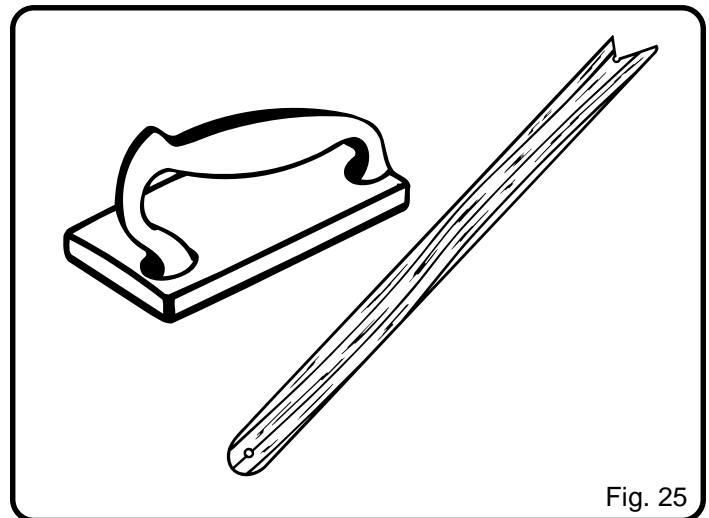

# OPERATION

## SAFETY CONSIDERATIONS

### AVOIDING KICKBACK

Kickback can occur when the blade stalls or binds, kicking the workpiece back toward the front of the saw with great force and speed. Kickback can cause serious injury. Precautions must be taken to avoid the risk of kickback.

The following can cause kickback and should be avoided:

- making a cut with incorrect blade depth.
- attempting to saw through knots or nails in the workpiece.
- twisting the wood while making a cut.
- failing to properly position the riving knife.
- making a cut with a dull, gummed-up, or improperly set blade.
- failing to support large workpieces.
- forcing the workpiece through the saw blade.
- cutting warped or wet lumber.
- not following correct operating procedures.
- failing to use the anti-kickback pawls.
- using the wrong blade for the type of cut.

### TO AVOID KICKBACK

1. Always use the correct blade depth setting. The top of the blade teeth should clear the workpiece by 1/8" to 1/4".
2. Inspect the workpiece for knots or nails before beginning a cut. Knock out any loose knots with a hammer. Never saw into a loose knot or nail.
3. Make straight cuts. Always use the rip fence when rip cutting. This helps prevent twisting the wood in the cut.
4. Always use clean, sharp, properly-set blades. Never make a cut with a dull blade.
5. To avoid pinching the blade, support the workpiece properly before beginning a cut.
6. When making a cut, use steady, even pressure. Never force a cut.
7. Do not cut wet or warped lumber.
8. Always hold your workpiece firmly with both hands or use push blocks, push sticks, and featherboards to keep your body in a balanced position to be able to resist kickback should it occur. Use featherboards and push sticks to control non-through cuts on small workpieces.

### **WARNING:**

Never stand directly in line with the blade or allow hands to come closer than 3 inches to the blade. Do not reach over or across the blade. Failure to comply can result in serious personal injury.

9. Use the right type of blade for the cut being made.

# MAINTENANCE

## GENERAL MAINTENANCE

### **⚠ WARNING:**

Always begin any maintenance procedure by disconnecting the saw from the power supply to avoid risk of serious personal injury.

1. Periodically check the tightness and condition of all nuts, bolts, and screws. Make sure that the throat plate is in proper position and securely attached.
2. Check the blade guard assembly for secure mounting and smooth operation.
3. To maintain the table surface, fence and rails, periodically apply paste wax to them and buff to provide smooth functioning. To prevent work from slipping during cutting operation, do not wax the working face of the miter gauge.
4. To improve function and prolong the life of your saw, periodically clean out sawdust from underneath the table and in the blade teeth. To keep blade clean, remove blade from saw and clean with resin solvent.
5. **Clean plastic parts only with a soft damp cloth. Do not use any aerosol or petroleum solvents.**

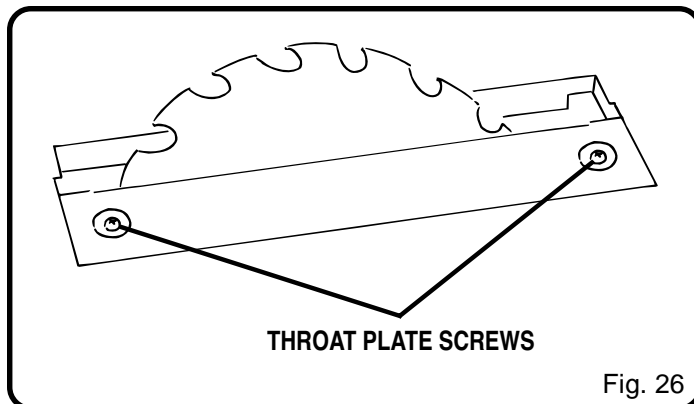

## SPECIFIC TABLE SAW MAINTENANCE

### To remove or change the blade

1. Raise the blade to the maximum height.
2. Remove the two screws holding the throat plate in place and remove the throat plate. *See Figure 26.*
3. To keep blade arbor from rotating, place the open ended wrench on flats located on the left side of the blade. *See Figure 27.*
4. Place the second wrench over the arbor nut located on the right side of the blade. Turn nut counterclockwise to loosen.
5. Remove arbor nut, washer and saw blade.
6. Position new blade on the arbor, making sure the teeth are pointing down toward the front of the table.
7. Attach washer and arbor nut.
8. Tighten arbor nut, making sure to hold the blade stationary with the open ended wrench.
9. Replace throat plate, making sure that the side with the rolled edge underneath is closest to the blade.
10. Securely attach throat plate with screws.

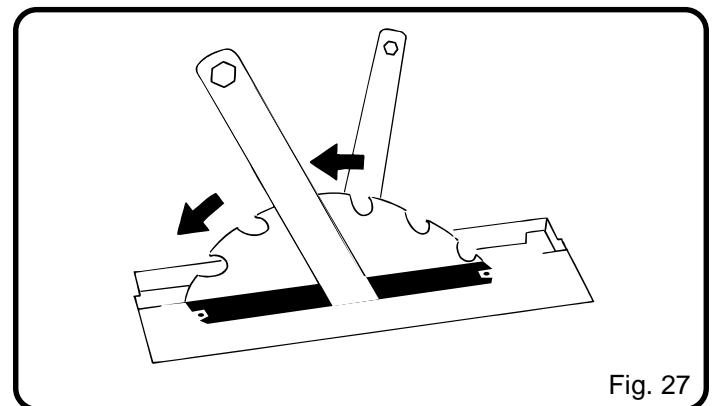

# TROUBLE SHOOTING

<b>Problem</b>	<b>Possible Cause</b>	<b>Solution</b>
Excess Vibration.	<ol style="list-style-type: none"> <li>1. Blade is out of balance.</li> <li>2. Blade is warped or damaged.</li> <li>3. Saw is not mounted securely to a level work surface.</li> </ol>	<ol style="list-style-type: none"> <li>1. Remount and recheck blade. Replace if necessary</li> <li>2. Replace blade immediately. See page 21.</li> <li>3. Reposition on a level surface and tighten all mounting hardware securely.</li> </ol>
Rip fence does not operate smoothly.	<ol style="list-style-type: none"> <li>1. Rip fence not mounted correctly.</li> <li>2. Rails are dirty or sticky.</li> <li>3. Adjustment nut needs adjusting.</li> </ol>	<ol style="list-style-type: none"> <li>1. Remount the rip fence. See page 11.</li> <li>2. Wax underneath front bar of rip fence and front rail.</li> <li>3. Adjust nut counterclockwise.</li> </ol>
Cutting binds or burns work.	<ol style="list-style-type: none"> <li>1. Blade is dull.</li> <li>2. Work is fed too fast.</li> <li>3. Rip fence is misaligned.</li> <li>4. Wood is warped.</li> <li>5. Blade is heeling.</li> </ol>	<ol style="list-style-type: none"> <li>1. Replace or have blade sharpened.</li> <li>2. Slow the feed rate.</li> <li>3. Align the rip fence. See page 14.</li> <li>4. Replace wood.</li> <li>5. Call Ryobi Technical Service at 1-800-525-2579</li> </ol>
Wood edges away from rip fence when ripping.	<ol style="list-style-type: none"> <li>1. Rip fence is misaligned.</li> <li>2. Blade not properly sharpened.</li> </ol>	<ol style="list-style-type: none"> <li>1. Check and adjust the rip fence. See page 14.</li> <li>2. Have blade resharpened.</li> </ol>
Saw does not make accurate 90° or 45° bevel cuts.	<ol style="list-style-type: none"> <li>1. Positive stops need adjusting.</li> </ol>	<ol style="list-style-type: none"> <li>1. Adjust positive stops. See pages 13 and 14.</li> </ol>
Saw does not make accurate 90° or 45° miter cuts.	<ol style="list-style-type: none"> <li>1. Miter gauge is misaligned.</li> </ol>	<ol style="list-style-type: none"> <li>1. Recheck setting on miter scale.</li> </ol>
Blade makes poor cuts.	<ol style="list-style-type: none"> <li>1. Blade is dull or dirty.</li> <li>2. Blade is wrong type for cut</li> <li>3. Blade is mounted backwards.</li> </ol>	<ol style="list-style-type: none"> <li>1. Clean blade (see page 21) or have blade sharpened.</li> <li>2. Replace with correct type.</li> <li>3. Remount blade. See page 21.</li> </ol>
Blade does not lower when turning blade control handle.	<ol style="list-style-type: none"> <li>1. Saw dust build up underneath saw.</li> </ol>	<ol style="list-style-type: none"> <li>1. Clean underside of saw.</li> </ol>
Motor labors in rip cut.	<ol style="list-style-type: none"> <li>1. Incorrect blade for rip cut.</li> </ol>	<ol style="list-style-type: none"> <li>1. Change blade to Ryobi 4650324, or similar 24-tooth, carbide rip blade.</li> </ol>

# NOTES

