

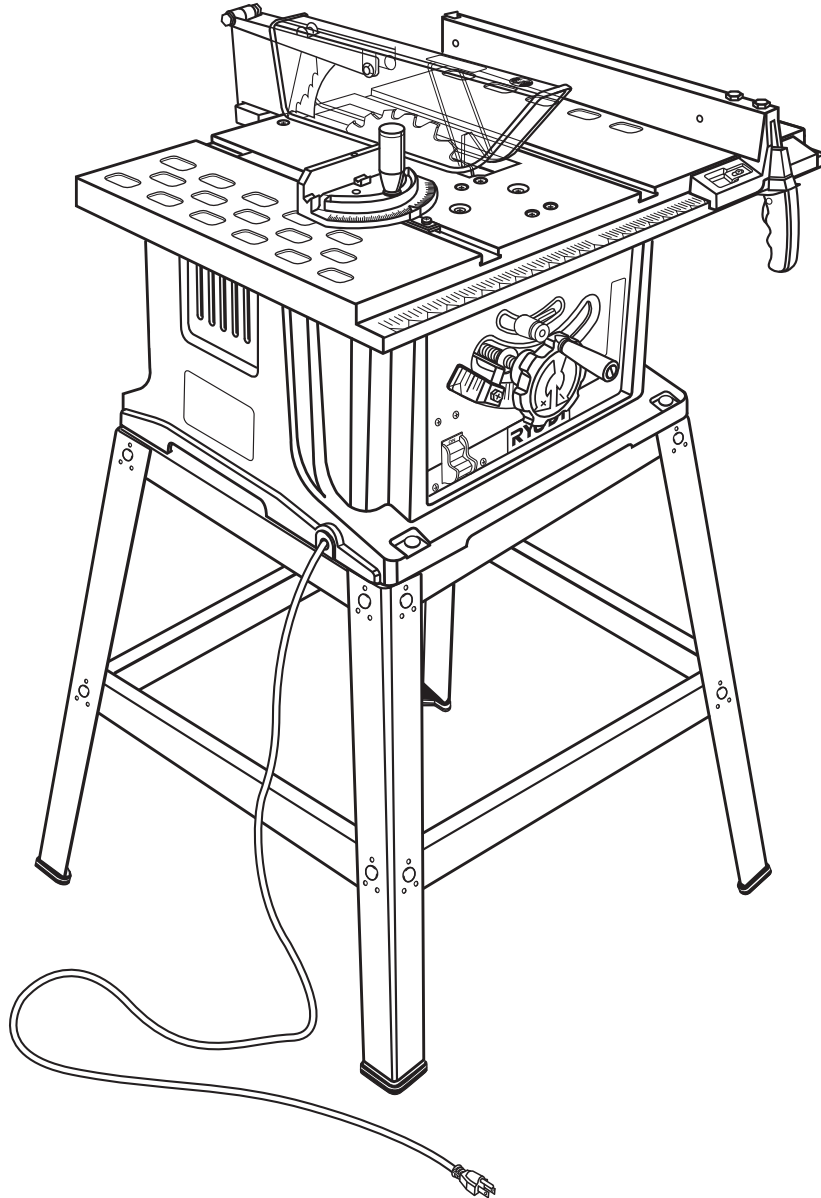

OPERATOR'S MANUAL

10 in. TABLE SAW

BTS12S



Your table saw has been engineered and manufactured to our high standard for dependability, ease of operation, and operator safety. When properly cared for, it will give you years of rugged, trouble-free performance.

⚠ WARNING: To reduce the risk of injury, the user must read and understand the operator's manual before using this product.

Thank you for your purchase.

SAVE THIS MANUAL FOR FUTURE REFERENCE

TABLE OF CONTENTS

■ Introduction	2
■ Warranty	2
■ General Safety Rules	3-4
■ Specific Safety Rules.....	5
■ Symbols.....	6-7
■ Electrical	8
■ Glossary of Terms.....	9
■ Features.....	10-12
■ Tools Needed.....	13
■ Loose Parts	14-15
■ Assembly	16-19
■ Operation.....	20-29
■ Adjustments.....	30-31
■ Maintenance.....	32
■ Troubleshooting.....	33
■ Parts Ordering / Service	Back page

INTRODUCTION

This tool has many features for making its use more pleasant and enjoyable. Safety, performance, and dependability have been given top priority in the design of this product making it easy to maintain and operate.

WARRANTY

RYOBI® POWER TOOL - LIMITED TWO YEAR WARRANTY AND 30 DAY EXCHANGE POLICY

One World Technologies, Inc., warrants its RYOBI® power tools with the following conditions:

30-DAY EXCHANGE POLICY: During the first 30 days after date of purchase, you may either request service under this warranty or you may exchange any RYOBI® power tool which does not work properly due to defective workmanship or materials by returning the power tool to the dealer from which it was purchased. To receive a replacement power tool or requested warranty service, you must present proof of purchase and return all original equipment packaged with the original product. The replacement power tool will be covered by the limited warranty for the balance of the two year period from the date of the original purchase.

WHAT THIS WARRANTY COVERS: This warranty covers all defects in workmanship or materials in your RYOBI® power tool for a period of two years from the date of purchase. With the exception of batteries, power tool accessories are warranted for ninety (90) days. Batteries are warranted for two years.

HOW TO GET SERVICE: Just return the power tool, properly packaged and postage prepaid, to an Authorized Service Center. You can obtain the location of the Service Center nearest you by contacting a service representative at One World Technologies, Inc., P.O. Box 1207, Anderson, SC 29622-1207, by calling 1-800-525-2579 or by logging on to www.ryobitools.com. When you request warranty service, you must also present proof of purchase documentation, which includes the date of purchase (for example, a bill of sale). We will repair any faulty workmanship, and either repair or replace any defective part, at our option. We will do so without any charge to you. We will complete the work in a reasonable time, but, in any case, within ninety (90) days or less.

WHAT'S NOT COVERED: This warranty applies only to the original purchaser at retail and may not be transferred. This warranty only covers defects arising under normal usage and does not cover any malfunction, failure or defects resulting from misuse, abuse, neglect, alteration, modification or repairs by other than Authorized Service Centers. One World Technologies, Inc. makes no warranties, representations or promises as to the quality or performance of its power tools other than those specifically stated in this warranty.

ADDITIONAL LIMITATIONS: Any implied warranties granted under state law, including warranties of merchantability or fitness for a particular purpose, are limited to two years from the date of purchase. One World Technologies, Inc. is not responsible for direct, indirect, or incidental damages, so the above limitations and exclusions may not apply to you. This warranty gives you specific legal rights, and you may also have other rights which vary from state to state.

GENERAL SAFETY RULES

WARNING:

Read and understand all instructions. Failure to follow all instructions listed below, may result in electric shock, fire and/or serious personal injury.

READ ALL INSTRUCTIONS

- **KNOW YOUR POWER TOOL.** Read the operator's manual carefully. Learn the saw's applications and limitations as well as the specific potential hazards related to this tool.
- **GUARD AGAINST ELECTRICAL SHOCK BY PREVENTING BODY CONTACT WITH GROUNDED SURFACES.** For example, pipes, radiators, ranges, refrigerator enclosures.
- **KEEP GUARDS IN PLACE** and in good working order.
- **REMOVE ADJUSTING KEYS AND WRENCHES.** Form habit of checking to see that keys and adjusting wrenches are removed from tool before turning it on.
- **KEEP WORK AREA CLEAN.** Cluttered areas and benches invite accidents. **DO NOT** leave tools or pieces of wood on the saw while it is in operation.
- **DO NOT USE IN DANGEROUS ENVIRONMENTS.** Do not use power tools in damp or wet locations or expose to rain. Keep the work area well lit.
- **KEEP CHILDREN AND VISITORS AWAY.** All visitors should wear safety glasses and be kept a safe distance from work area. Do not let visitors contact tool or extension cord while operating.
- **MAKE WORKSHOP CHILDPROOF** with padlocks and master switches, or by removing starter keys.
- **DON'T FORCE TOOL.** It will do the job better and safer at the feed rate for which it was designed.
- **USE RIGHT TOOL.** Don't force the tool or attachment to do a job it was not designed for. Don't use it for a purpose not intended.
- **USE THE PROPER EXTENSION CORD.** Make sure your extension cord is in good condition. Use only a cord heavy enough to carry the current your product will draw. An undersized cord will cause a drop in line voltage resulting in loss of power and overheating. A wire gauge size (A.W.G.) of at least **14** is recommended for an extension cord 25 feet or less in length. If in doubt, use the next heavier gauge. The smaller the gauge number, the heavier the cord.
- **DRESS PROPERLY.** Do not wear loose clothing, gloves, neckties, or jewelry. They can get caught and draw you into moving parts. Rubber gloves and nonskid footwear are recommended when working outdoors. Also wear protective hair covering to contain long hair.
- **ALWAYS WEAR SAFETY GLASSES WITH SIDE SHIELDS.** Everyday eyeglasses have only impact-resistant lenses, they are **NOT** safety glasses.
- **SECURE WORK.** Use a featherboard to hold work when practical. It's safer than using your hand and frees both hands to operate tool.
- **DON'T OVERREACH.** Keep proper footing and balance at all times.
- **MAINTAIN TOOLS WITH CARE.** Keep tools sharp and clean for better and safer performance. Follow instructions for lubricating and changing accessories.
- **DISCONNECT TOOLS.** When not in use, before servicing, or when changing attachments, blades, bits, cutters, etc., all tools should be disconnected.
- **AVOID ACCIDENTAL STARTING.** Be sure switch is off when plugging in any tool.
- **USE RECOMMENDED ACCESSORIES.** Consult the operator's manual for recommended accessories. The use of improper accessories may risk injury.
- **NEVER STAND ON TOOL.** Serious injury could occur if the tool is tipped or if the cutting tool is unintentionally contacted.
- **CHECK DAMAGED PARTS.** Before further use of the tool, a guard or other part that is damaged should be carefully checked to determine that it will operate properly and perform its intended function. Check for alignment of moving parts, binding of moving parts, breakage of parts, mounting and any other conditions that may affect its operation. A guard or other part that is damaged must be properly repaired or replaced by an authorized service center to avoid risk of personal injury.
- **USE THE RIGHT DIRECTION OF FEED.** Feed work into a blade or cutter against the direction of rotation of blade or cutter only.
- **NEVER LEAVE TOOL RUNNING UNATTENDED. TURN THE POWER OFF.** Don't leave tool until it comes to a complete stop.
- **PROTECT YOUR LUNGS.** Wear a face or dust mask if the cutting operation is dusty.
- **PROTECT YOUR HEARING.** Wear hearing protection during extended periods of operation.
- **DO NOT ABUSE CORD.** Never yank cord to disconnect from receptacle. Keep cord away from heat, oil, and sharp edges.
- **WHEN OPERATING A POWER TOOL OUTSIDE, USE AN OUTDOOR EXTENSION CORD MARKED "W-A" OR "W".** These cords are rated for outdoor use and reduce the risk of electric shock.
- **ALWAYS KEEP THE BLADE GUARD AND SPREADER (SPLITTER) IN PLACE** and in working order.

GENERAL SAFETY RULES







- **KEEP BLADES CLEAN, SHARP, AND WITH SUFFICIENT SET.** Sharp blades minimize stalling and kickback.
- **KEEP HANDS AWAY FROM CUTTING AREA.** Keep hands away from blades. Do not reach underneath work or around or over the blade while blade is rotating. Do not attempt to remove cut material when blade is moving.
- **BLADE COASTS AFTER BEING TURNED OFF.**
- **NEVER USE IN AN EXPLOSIVE ATMOSPHERE.** Normal sparking of the motor could ignite fumes.
- **INSPECT TOOL CORDS PERIODICALLY.** If damaged, have repaired by a qualified service technician at an authorized service facility. The conductor with insulation having an outer surface that is green with or without yellow stripes is the equipment-grounding conductor. If repair or replacement of the electric cord or plug is necessary, do not connect the equipment-grounding conductor to a live terminal. Repair or replace a damaged or worn cord immediately. Stay constantly aware of cord location and keep it well away from the rotating blade.
- **INSPECT EXTENSION CORDS PERIODICALLY** and replace if damaged.
- **GROUND ALL TOOLS.** If tool is equipped with three-prong plug, it should be plugged into a three-hole electrical receptacle.
- **CHECK WITH A QUALIFIED ELECTRICIAN** or service personnel if the grounding instructions are not completely understood or if in doubt as to whether the tool is properly grounded.
- **USE ONLY CORRECT ELECTRICAL DEVICES:** 3-wire extension cords that have 3-prong grounding plugs and 3-pole receptacles that accept the tool's plug.
- **DO NOT MODIFY** the plug provided. If it will not fit the outlet, have the proper outlet installed by a qualified electrician.
- **KEEP TOOL DRY, CLEAN, AND FREE FROM OIL AND GREASE.** Always use a clean cloth when cleaning. Never use brake fluids, gasoline, petroleum-based products, or any solvents to clean tool.
- **STAY ALERT AND EXERCISE CONTROL.** Watch what you are doing and use common sense. Do not operate tool when you are tired. Do not rush.
- **DO NOT USE TOOL IF SWITCH DOES NOT TURN IT ON AND OFF.** Have defective switches replaced by an authorized service center.
- **USE ONLY CORRECT BLADES.** Do not use blades with incorrect size holes. Never use blade washers or blade bolts that are defective or incorrect. The maximum blade capacity of your saw is 10 in.
- **BEFORE MAKING A CUT, BE SURE ALL ADJUSTMENTS ARE SECURE.**
- **BE SURE BLADE PATH IS FREE OF NAILS.** Inspect for and remove all nails from lumber before cutting.
- **NEVER TOUCH BLADE** or other moving parts during use.
- **NEVER START A TOOL WHEN ANY ROTATING COMPONENT IS IN CONTACT WITH THE WORKPIECE.**
- **DO NOT OPERATE A TOOL WHILE UNDER THE INFLUENCE OF DRUGS, ALCOHOL, OR ANY MEDICATION.**
- **WHEN SERVICING** use only identical replacement parts. Use of any other parts may create a hazard or cause product damage.
- **USE ONLY RECOMMENDED ACCESSORIES** listed in this manual or addendums. Use of accessories that are not listed may cause the risk of personal injury. Instructions for safe use of accessories are included with the accessory.
- **DOUBLE CHECK ALL SETUPS.** Make sure blade is tight and not making contact with saw or workpiece before connecting to power supply.

SPECIFIC SAFETY RULES

- **FIRMLY BOLT THE SAW TO A WORK BENCH OR LEG STAND** at approximately hip height.
- **NEVER OPERATE THE SAW ON THE FLOOR.**
- **GUARD AGAINST KICKBACK.** Kickback occurs when the blade stalls rapidly and workpiece is driven back towards the operator. It can pull your hand into the blade resulting in serious personal injury. Stay out of blade path and turn switch off immediately if blade binds or stalls.
- **USE RIP FENCE.** Always use a fence or straight edge guide when ripping.
- **SUPPORT LARGE PANELS.** To minimize risk of blade pinching and kickback, always support large panels.
- **REMOVE ALL FENCES AND AUXILIARY TABLES** before transporting saw. Failure to do so can result in an accident causing possible serious personal injury.
- **ALWAYS USE BLADE GUARD, SPREADER, AND ANTI-KICKBACK PAWLS** on all “through-sawing” operations. Through-sawing operations are those in which the blade cuts completely through the workpiece as in ripping or cross cutting. Keep the blade guard down, the anti-kickback pawls down, and the spreader in place over the blade.
- **ALWAYS SECURE WORK** firmly against the rip fence or miter gauge. **NEVER** use the rip fence during the same operation as the miter gauge.
- **ALWAYS USE A PUSH STICK FOR RIPPING NARROW STOCK.** A push stick is a device used to push a workpiece through the blade instead of using your hands. Size and shape can vary but the push stick must always be narrower than the workpiece to prevent the push stick from contacting the saw blade. When ripping narrow stock, always use a push stick, so your hand does not come close to the saw blade. Use a featherboard and push blocks for non-through cuts.
- **NEVER** perform any operation “freehand” which means using only your hands to support or guide the workpiece. Always use either the rip fence or miter fence to position and guide the work.
- **NEVER** stand or have any part of your body in line with the path of the saw blade.
- **NEVER** reach behind, over, or within three inches of the blade or cutter with either hand for any reason.
- **MOVE THE RIP FENCE** out of the way when cross cutting.
- **DO NOT USE THE MITER GAUGE AND RIP FENCE** during the same operation.
- **NEVER** use rip fence as cutoff gauge when cross cutting.
- **NEVER** attempt to free a stalled saw blade without first turning the saw **OFF** and disconnecting the saw from the power source.
- **PROVIDE ADEQUATE SUPPORT** to the rear and sides of the saw table for wide or long work pieces.
- **AVOID KICKBACKS** (work thrown back toward you) by:
 - a) Keeping blade sharp.
 - b) Keeping rip fence parallel to the saw blade.
 - c) Keeping spreader, anti-kickback pawls, and blade guard in place and operating.
 - d) Not releasing the work before it is pushed all the way past the saw blade using a push stick.
 - e) Not ripping work that is twisted or warped or does not have a straight edge to guide along the fence.
- **IF THE POWER SUPPLY CORD IS DAMAGED**, it must be replaced only by the manufacturer or by an authorized service center to avoid risk.
- **AVOID AWKWARD OPERATIONS AND HAND POSITIONS** where a sudden slip could cause your hand to move into the cutting tool.
- **USE ONLY RECOMMENDED ACCESSORIES** listed in this manual or addendums. Use of accessories that are not listed may cause the risk of personal injury. Instructions for safe use of accessories are included with the accessory.
- **MAKE SURE THE WORK AREA HAS AMPLE LIGHTING** to see the work and that no obstructions will interfere with safe operation **BEFORE** performing any work using the table saw.
- **ALWAYS TURN OFF SAW** before disconnecting it, to avoid accidental starting when reconnecting to power supply.
- **THIS TOOL** should have the following markings:
 - a) Wear eye protection.
 - b) Use saw blade guard and spreader/riving knife for every operation for which it can be used, including all through sawing.
 - c) Keep hands out of the line of saw blade.
 - d) Use a push stick when required.
 - e) Pay particular attention to instructions on reducing risk of kickback.
 - f) Do not perform any operation freehand.
 - g) Never reach around or over the saw blade.
- **SAVE THESE INSTRUCTIONS.** Refer to them frequently and use to instruct other users. If you loan someone this tool, loan them these instructions also.



SYMBOLS

Some of the following symbols may be used on this tool. Please study them and learn their meaning. Proper interpretation of these symbols will allow you to operate the tool better and safer.

SYMBOL	NAME	DESIGNATION/EXPLANATION
V	Volts	Voltage
A	Amperes	Current
Hz	Hertz	Frequency (cycles per second)
W	Watt	Power
min	Minutes	Time
~	Alternating Current	Type of current
≡	Direct Current	Type or a characteristic of current
n_0	No Load Speed	Rotational speed, at no load
	Class II Construction	Double-insulated construction
.../min	Per Minute	Revolutions, strokes, surface speed, orbits etc., per minute
	Wet Conditions Alert	Do not expose to rain or use in damp locations.
	Read The Operator's Manual	To reduce the risk of injury, user must read and understand operator's manual before using this product.
	Eye Protection	Always wear safety goggles or safety glasses with side shields and, as necessary, a full face shield when operating this product.
	Safety Alert	Precautions that involve your safety.
	No Hands Symbol	Failure to keep your hands away from the blade will result in serious personal injury.
	Hot Surface	To reduce the risk of injury or damage, avoid contact with any hot surface.

SYMBOLS

The following signal words and meanings are intended to explain the levels of risk associated with this product.

SYMBOL	SIGNAL	MEANING
	DANGER:	Indicates an imminently hazardous situation, which, if not avoided, will result in death or serious injury.
	WARNING:	Indicates a potentially hazardous situation, which, if not avoided, could result in death or serious injury.
	CAUTION:	Indicates a potentially hazardous situation, which, if not avoided, may result in minor or moderate injury.
	CAUTION:	(Without Safety Alert Symbol) Indicates a situation that may result in property damage.

SERVICE

Servicing requires extreme care and knowledge and should be performed only by a qualified service technician. For service we suggest you return the product to the nearest **AUTHORIZED SERVICE CENTER** for repair. When servicing, use only identical replacement parts.

WARNING:

To avoid serious personal injury, do not attempt to use this product until you read thoroughly and understand completely the operator's manual. If you do not understand the warnings and instructions in the operator's manual, do not use this product. Call Ryobi customer service for assistance.

WARNING:



The operation of any power tool can result in foreign objects being thrown into your eyes, which can result in severe eye damage. Before beginning power tool operation, always wear safety goggles or safety glasses with side shields and, when needed, a full face shield. We recommend Wide Vision Safety Mask for use over eyeglasses or standard safety glasses with side shields. Always use eye protection which is marked to comply with ANSI Z87.1.

SAVE THESE INSTRUCTIONS

ELECTRICAL

EXTENSION CORDS

Use only 3-wire extension cords that have 3-prong grounding plugs and 3-pole receptacles that accept the tool's plug. When using a power tool at a considerable distance from the power source, use an extension cord heavy enough to carry the current that the tool will draw. An undersized extension cord will cause a drop in line voltage, resulting in a loss of power and causing the motor to overheat. Use the chart provided below to determine the minimum wire size required in an extension cord. Only round jacketed cords listed by Underwriter's Laboratories (UL) should be used.

**Ampere rating (on tool data plate)

Cord Length	Wire Size (A.W.G.)					
	0-2.0	2.1-3.4	3.5-5.0	5.1-7.0	7.1-12.0	12.1-16.0
25'	16	16	16	16	14	14
50'	16	16	16	14	14	12
100'	16	16	14	12	10	—

**Used on 12 gauge - 20 amp circuit.

NOTE: AWG = American Wire Gauge

When working with the tool outdoors, use an extension cord that is designed for outside use. This is indicated by the letters "W-A" or "W" on the cord's jacket.

Before using an extension cord, inspect it for loose or exposed wires and cut or worn insulation.

⚠ WARNING:

Keep the extension cord clear of the working area. Position the cord so that it will not get caught on lumber, tools or other obstructions while you are working with a power tool. Failure to do so can result in serious personal injury.

⚠ WARNING:

Check extension cords before each use. If damaged replace immediately. Never use tool with a damaged cord since touching the damaged area could cause electrical shock resulting in serious injury.

ELECTRICAL CONNECTION

This tool is powered by a precision built electric motor. It should be connected to a **power supply that is 120 V, AC only (normal household current), 60 Hz**. Do not operate this tool on direct current (DC). A substantial voltage drop will cause a loss of power and the motor will overheat. If the saw does not operate when plugged into an outlet, double check the power supply.

SPEED AND WIRING

The no-load speed of this tool is approximately 4,800 rpm. This speed is not constant and decreases under a

load or with lower voltage. For voltage, the wiring in a shop is as important as the motor's horsepower rating. A line intended only for lights cannot properly carry a power tool motor. Wire that is heavy enough for a short distance will be too light for a greater distance. A line that can support one power tool may not be able to support two or three tools.

GROUNDING INSTRUCTIONS

This product must be grounded. In the event of a malfunction or breakdown, grounding provides a path of least resistance for electric current to reduce the risk of electric shock. This tool is equipped with an electric cord having an equipment-grounding conductor and a grounding plug. The plug must be plugged into a matching outlet that is properly installed and grounded in accordance with all local codes and ordinances.

Do not modify the plug provided. If it will not fit the outlet, have the proper outlet installed by a qualified electrician.

⚠ WARNING:

Improper installation of the grounding plug is able to result in a risk of electric shock. When repair or replacement of the cord is required, do not connect the grounding wire to either flat blade terminal. The wire with insulation having an outer surface that is green with or without yellow stripes is the grounding wire.

Check with a qualified electrician or service personnel if the grounding instructions are not completely understood, or if in doubt as to whether the tool is properly grounded.

Repair or replace a damaged or worn cord immediately.

This product is for use on a nominal 120 volt circuit and has a grounding plug similar to the plug illustrated in figure 1. Only connect the product to an outlet having the same configuration as the plug. Do not use an adapter with this product.

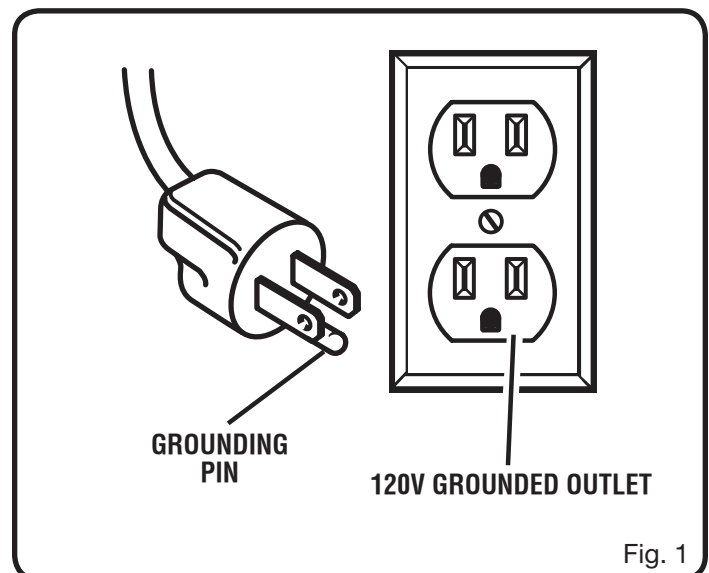

Fig. 1

GLOSSARY OF TERMS

Anti-Kickback Pawls (radial arm and table saws)

A device which, when properly installed and maintained, is designed to stop the workpiece from being kicked back toward the front of the saw during a ripping operation.

Arbor

The shaft on which a blade or cutting tool is mounted.

Bevel Cut

A cutting operation made with the blade at any angle other than 90° to the table surface.

Chamfer

A cut removing a wedge from a block so the end (or part of the end) is angled rather than at 90°.

Compound Cut

A cross cut made with both a miter and a bevel angle.

Cross Cut

A cutting or shaping operation made across the grain or the width of the workpiece.

Cutter Head (planers and jointer planers)

A rotating cutterhead with adjustable blades or knives. The blades or knives remove material from the workpiece.

Dado Cut

A non-through cut which produces a square-sided notch or trough in the workpiece (requires a special blade).

Featherboard

A device used to help control the workpiece by guiding it securely against the table or fence during any ripping operation.

FPM or SPM

Feet per minute (or strokes per minute), used in reference to blade movement.

Freehand

Performing a cut without the workpiece being guided by a fence, miter gauge, or other aids.

Gum

A sticky, sap-based residue from wood products.

Heel

Alignment of the blade to the fence.

Kerf

The material removed by the blade in a through cut or the slot produced by the blade in a non-through or partial cut.

Kickback

A hazard that can occur when the blade binds or stalls, throwing the workpiece back toward operator.

Leading End

The end of the workpiece pushed into the tool first.

Miter Cut

A cutting operation made with the workpiece at any angle to the blade other than 90°.

Non-Through Cuts

Any cutting operation where the blade does not extend completely through the thickness of the workpiece.

Pilot Hole (drill presses)

A small hole drilled in a workpiece that serves as a guide for drilling large holes accurately.

Push Blocks (for jointer planers)

Device used to feed the workpiece over the jointer planer cutterhead during any operation. This aid helps keep the operator's hands well away from the cutterhead.

Push Blocks and Push Sticks (for table saws)

Devices used to feed the workpiece through the saw blade during cutting operations. A push stick (not a push block) should be used for narrow ripping operations. These aids help keep the operator's hands well away from the blade.

Resaw

A cutting operation to reduce the thickness of the workpiece to make thinner pieces.

Resin

A sticky, sap-based substance that has hardened.

Revolutions Per Minute (RPM)

The number of turns completed by a spinning object in one minute.

Ripping or Rip Cut

A cutting operation along the length of the workpiece.

Riving Knife/Spreader/Splitter (table saws)

A metal piece, slightly thinner than the blade, which helps keep the kerf open and also helps to prevent kickback.

Saw Blade Path

The area over, under, behind, or in front of the blade. As it applies to the workpiece, that area which will be or has been cut by the blade.

Set

The distance that the tip of the saw blade tooth is bent (or set) outward from the face of the blade.

Snipe (planers)

Depression made at either end of a workpiece by cutter blades when the workpiece is not properly supported.

Through Sawing

Any cutting operation where the blade extends completely through the thickness of the workpiece.

Throw-Back

The throwing back of a workpiece usually caused by the workpiece being dropped into the blade or being placed inadvertently in contact with the blade.

Workpiece or Material

The item on which the operation is being done.

Worktable

Surface where the workpiece rests while performing a cutting, drilling, planing, or sanding operation.

FEATURES

PRODUCT SPECIFICATIONS

Blade Diameter.....	10 in.	Table Size	25-3/4 in. x 16 in.
Blade Arbor	5/8 in.	Input	120 V, AC only, 60 Hz, 13 A
Cutting Depth at 0°.....	3 in.	No Load Speed	4,800 r/min. (RPM)
Cutting Depth at 45°.....	2-5/8 in.		

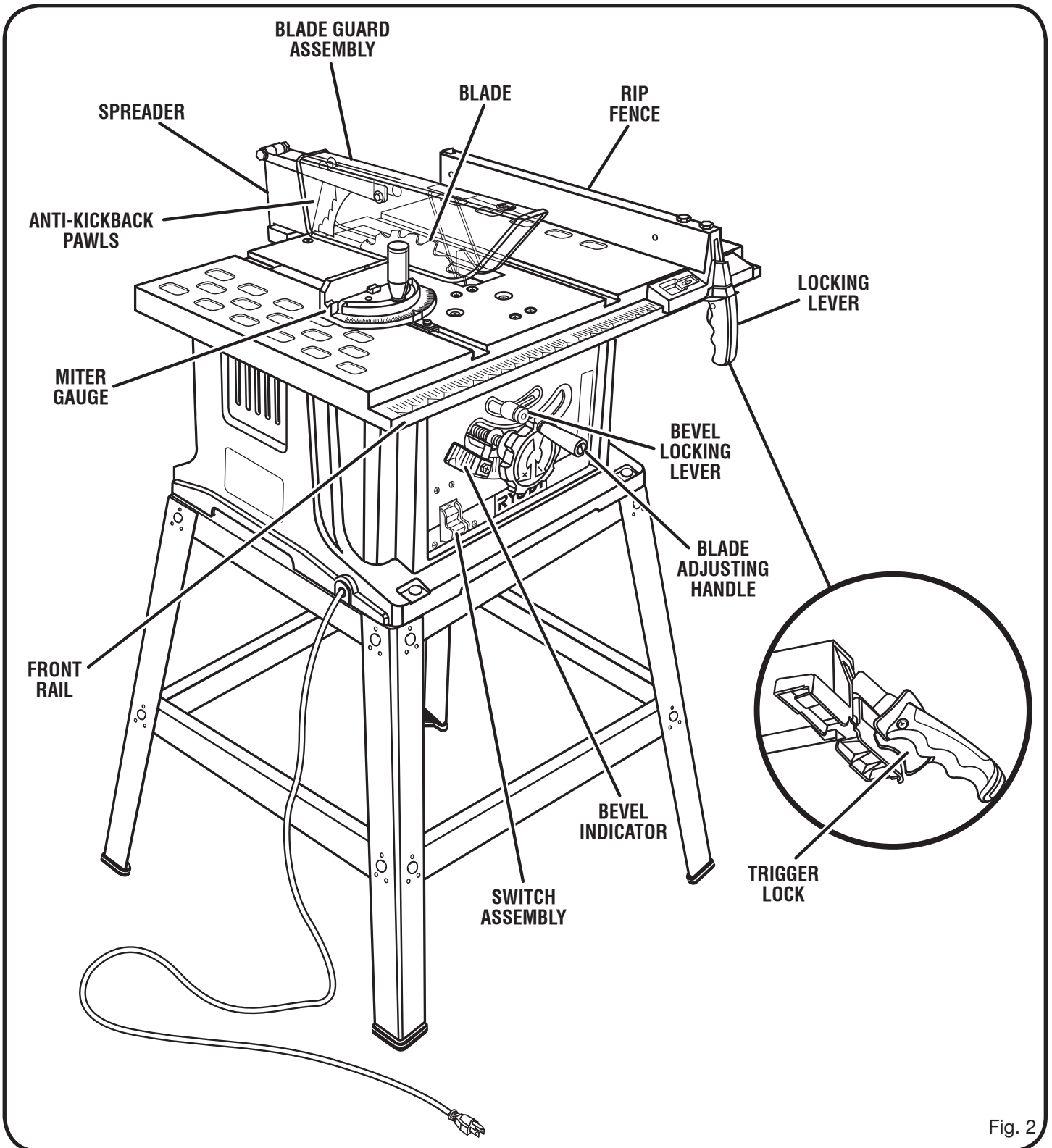

Fig. 2

FEATURES

KNOW YOUR TABLE SAW

See Figure 2.

The safe use of this product requires an understanding of the information on the tool and in this operator's manual as well as a knowledge of the project you are attempting. Before use of this product, familiarize yourself with all operating features and safety rules.

OVERVIEW

The upper portion of the blade projects up through the table, surrounded by an insert called the throat plate. The height of the blade is set with a blade adjusting handle on the front of the cabinet. To cut wood at a bevel, the blade must be tilted using the blade adjusting handle, the bevel lock lever, and the bevel indicator found on the front of the cabinet. Detailed instructions are provided in the *Operation* section of this manual for the basic cuts: rip cuts, cross cuts, miter cuts, bevel cuts, and compound cuts.

This saw includes a rip fence and miter gauge. The rip fence is used to position work that will be cut lengthwise (rip cuts). Push smaller pieces with a push block or push stick. A scale on the front of the saw table shows the distance between the rip fence and the blade. For cuts with the blade straight up and cutting across the grain (cross cuts or miter cuts), use the miter gauge to set the angle and push the wood into the blade.

Use the miter gauge for a bevel cross cut (compound cut) and the rip fence for a bevel rip cut.

The blade guard assembly includes a spreader which is a metal device directly behind and above the blade. It is used to help keep the cut wood from binding together and causing possible kickback. It is very important to use the spreader for all through-sawing operations. The anti-kickback pawls (also a part of the blade guard assembly) are toothed plates mounted on the spreader. Their teeth point away from the work in case the work should be thrown or pulled back toward the operator. Then the teeth dig into the wood to help prevent or reduce the possibility of kickback.

ANTI-KICKBACK PAWLS - Kickback is a hazard in which the workpiece is thrown back toward the operator. The toothed pawls are designed to snag the workpiece to prevent or reduce injury should kickback occur.

BEVEL SCALE - The easy-to-read scale on the front of the cabinet shows the exact blade angle.

BLADE - This saw comes with a 10 in, 24-tooth blade. The blade is adjusted with the blade adjusting handle on the front of the cabinet. Bevel angles are locked with a bevel locking lever below the front rail.

WARNING:

Do not use blades rated less than the speed of this tool. Failure to heed this warning could result in personal injury.

BLADE ADJUSTING HANDLE - Use this handle to set the angle of the blade for bevel cuts and to lower or raise the blade for adjustments. This handle is located on the front of the cabinet.

BLADE GUARD - Always keep the guard down over the blade for through-sawing cuts.

BEVEL LOCKING LEVER - This lever, placed just under the worktable surface on the front of the cabinet, locks the angle setting of the blade. Be sure the lever is unlocked before tilting the blade. If it is not unlocked, it may jam and bend the locking bolt.

MITER GAUGE - This miter gauge aligns the wood for a cross cut. The easy-to-read indicator shows the exact angle for a miter cut.

MITER GAUGE GROOVES - The miter gauge rides in these grooves on either side of the blade.

RIP FENCE - A metal fence guides the workpiece and is secured with a locking lever. When the locking lever is in the locked position, it cannot be unlocked until the trigger lock is pulled.

SCALE - Found on the front of the saw table, the easy-to-read scale provides precise measurements in rip cuts.

SPREADER - A metal piece, slightly thinner than the saw blade, which helps keep the kerf open and prevent kickback.

SWITCH ASSEMBLY - The saw has an easy access power switch located below the front rail. The switch key must be inserted into the switch before the saw can be operated. To lock the switch in the **OFF** position, remove the switch key from the switch. Place the key in a location that is inaccessible to children and others not qualified to use the tool.

FEATURES

BLADES

For maximum performance, it is recommended that you use the 10 in., 24-tooth blade provided with your saw. Additional blade styles of the same high quality are available for specific operations such as ripping. Your local dealer can provide you with complete information.

WARNING:

Do not use blades rated less than the speed of this tool. Failure to heed this warning could result in personal injury.

WARNING:

To prevent possible electrical hazards, have a qualified electrician check the line if you are not certain that it is properly wired.

POWER SWITCH

See Figure 3.

Your table saw is equipped with a power switch that has a built-in locking feature. This feature is intended to prevent unauthorized and possible hazardous use by children and others.

TO TURN YOUR SAW ON:

- With the switch key inserted into the switch, lift the switch button to turn **ON**.

TO TURN YOUR SAW OFF:

- Press the switch button down to turn **OFF**.

TO LOCK YOUR SAW:

- With the saw turned **OFF**, pull the switch key from the switch and store in a safe, secure location.

WARNING:

In the event of a power failure or when the tool is not in use, turn the switch OFF and remove the switch key. This action will prevent the tool from accidentally starting when power returns.

WARNING:

ALWAYS make sure your workpiece is not in contact with the blade before operating the switch to start the tool. Failure to heed this warning may cause the workpiece to be kicked back toward the operator and result in serious personal injury.

WARNING:

To reduce the risk of accidental starting, ALWAYS make sure the switch is in the OFF position before plugging tool into the power source or resetting the overload reset button.

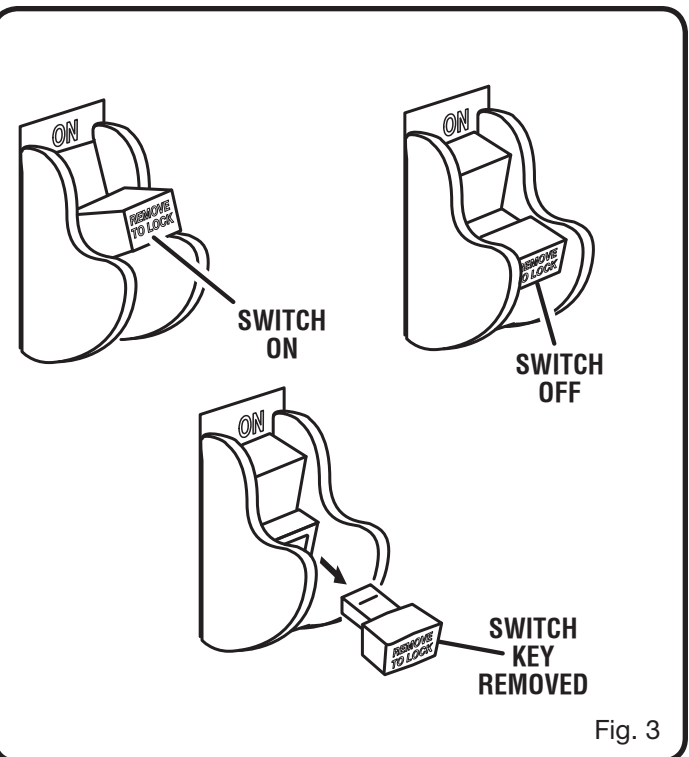
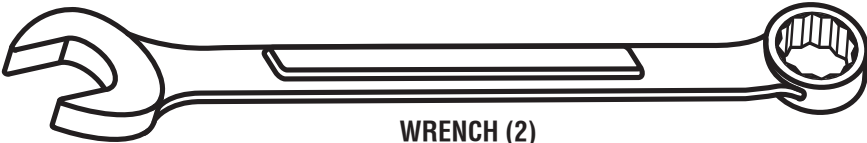

Fig. 3

TOOLS NEEDED

The following tools (not included or drawn to scale) are needed for assembly and making adjustments:



WRENCH (2)
10 mm, 12 mm



**PHILLIPS
SCREWDRIVER**

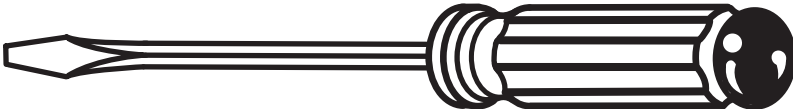

**FLATHEAD
SCREWDRIVER**



FRAMING SQUARE

Fig. 4

LOOSE PARTS LIST

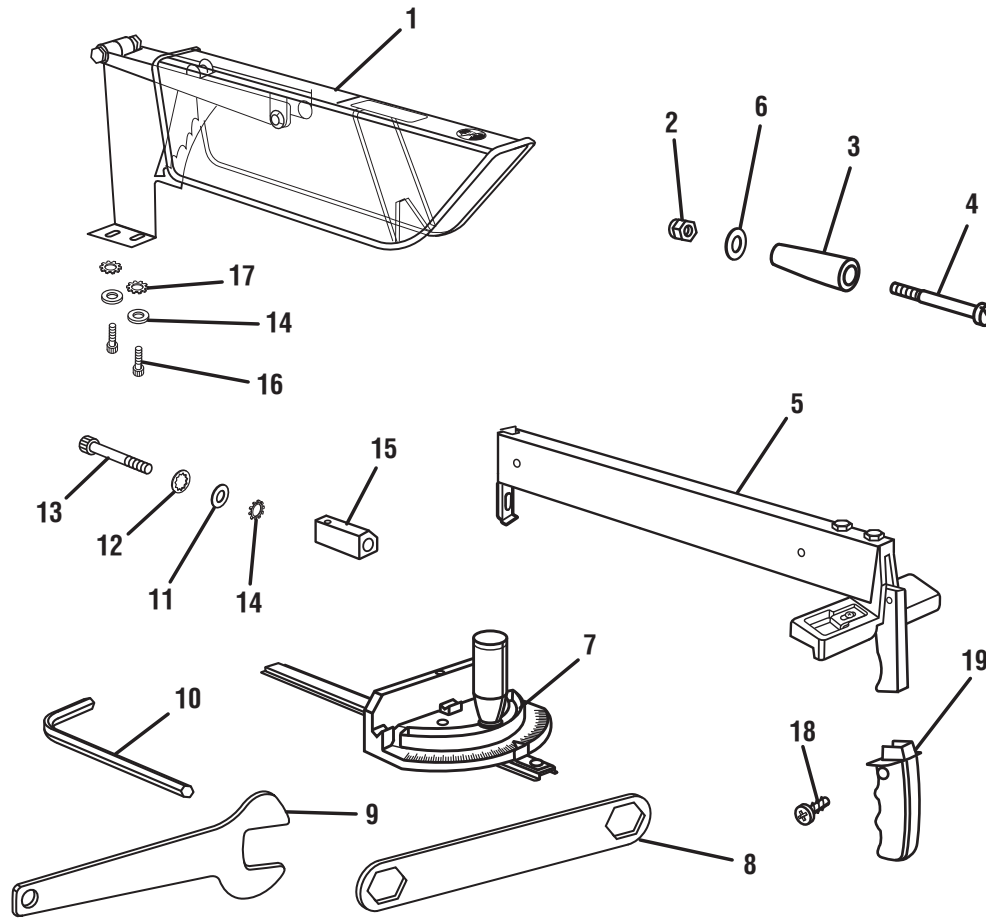

Fig. 5

1	Blade Guard Assembly.....	1
2	Lock Nut.....	1
3	Blade Adjusting Handle.....	1
4	Shoulder Bolt.....	1
5	Rip Fence	1
6	Flat Washer.....	1
7	Miter Gauge	1
8	Small Wrench	1
9	Large Wrench	1
10	Hex Key (5 mm).....	1
11	Flat Washer (1/4 in.).....	1
12	Internal Tooth Lock Washer (1/4 in.).....	1
13	Socket Head Bolt (1/4 - 20 x 2-1/4 in.).....	1
14	Flat Washer.....	3
15	Mounting Bracket.....	1
16	Socket Head Cap Screw	2
17	External Tooth Lock Washer (1/4 in.).....	2
18	Tapping Screw.....	1
19	Locking Handle	1
20	Operator's Manual (Not Shown)	

LOOSE PARTS LIST

The following items are included with the table saw leg stand:

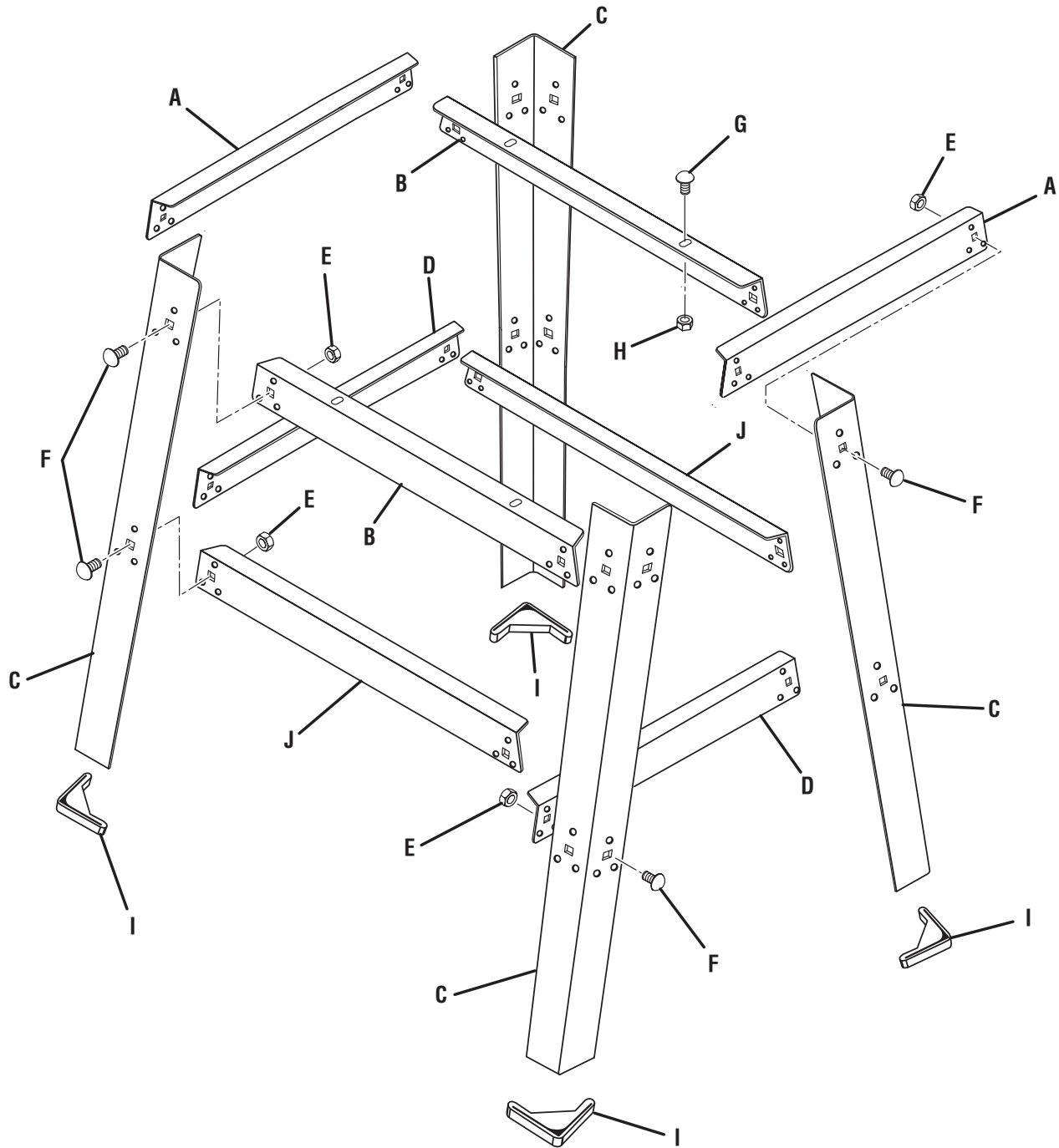

Fig. 3

<p>A. Upper Side Brace 2</p> <p>B. Upper Brace 2</p> <p>C. Leg 4</p> <p>D. Lower Side Brace 2</p> <p>E. Hex Nut 16</p>	<p>F. Carriage Bolt (5/16-18 x 5/8 in.) 16</p> <p>G. Carriage Bolt (1/4-20 x 1-5/8 in.) 4</p> <p>H. Hex Nut 4</p> <p>I. Foot 4</p> <p>J. Lower Brace 2</p>
--	--

ASSEMBLY

UNPACKING

This product requires assembly.

- Carefully remove the tool and any accessories from the box. Place it on a level work surface.
- Inspect the tool carefully to make sure no breakage or damage occurred during shipping.
- Do not discard the packing material until you have carefully inspected the tool, identified all loose parts, and satisfactorily operated the tool.

NOTE: Remove the foam block from between the saw's housing and the motor.

- The saw is factory set for accurate cutting. After assembling it, check for accuracy. If shipping has influenced the settings, refer to specific procedures explained in this manual.
- If any parts are damaged or missing, please call 1-800-525-2579 for assistance.

WARNING:

If any parts are damaged or missing do not operate this tool until the parts are replaced. Failure to heed this warning could result in serious personal injury.

WARNING:

Do not attempt to modify this tool or create accessories not recommended for use with this tool. Any such alteration or modification is misuse and could result in a hazardous condition leading to possible serious personal injury.

WARNING:

Do not connect to power supply until assembly is complete. Failure to comply could result in accidental starting and possible serious personal injury.

WARNING:

Never stand directly in line with the blade or allow hands to come closer than 3 in. to the blade. Do not reach over or across the blade. Failure to heed this warning can result in serious personal injury.

WARNING:

To avoid serious personal injury, always make sure the table saw is securely mounted to a workbench or an approved leg stand. NEVER operate the saw on the floor.

TO ASSEMBLE THE LEG STAND

See Figure 6.

Assembly is best done in the area where the saw will be used. If you are unsure about the description of any part, refer to the drawing. If any parts are missing, delay assembling until you have obtained the missing part(s).

- Take the following from a small hardware pack:
 - 16 - 5/16 in. 18-UNC 5/8 in. bolts
 - 16 - 5/16 in. hex nuts
- Take 4 legs and 8 braces from loose parts.
- Place an upper brace inside two of the legs, with the legs wide end up. (Upper braces have two large holes in each end.) Make sure the dimples on the leg align with the small holes on the brace.
- Align the large holes on the brace and the legs. Insert the bolts. Add hex nuts and hand tighten. Repeat for the other upper brace. These are the front and back sets.
- For the side sets, install an upper side brace on two legs. Add hardware and finger tighten.
- Use the same steps to install the lower braces. Tighten all hex nuts with a wrench.
- Install a foot to the bottom of each leg.
- Move the leg set to desired location.

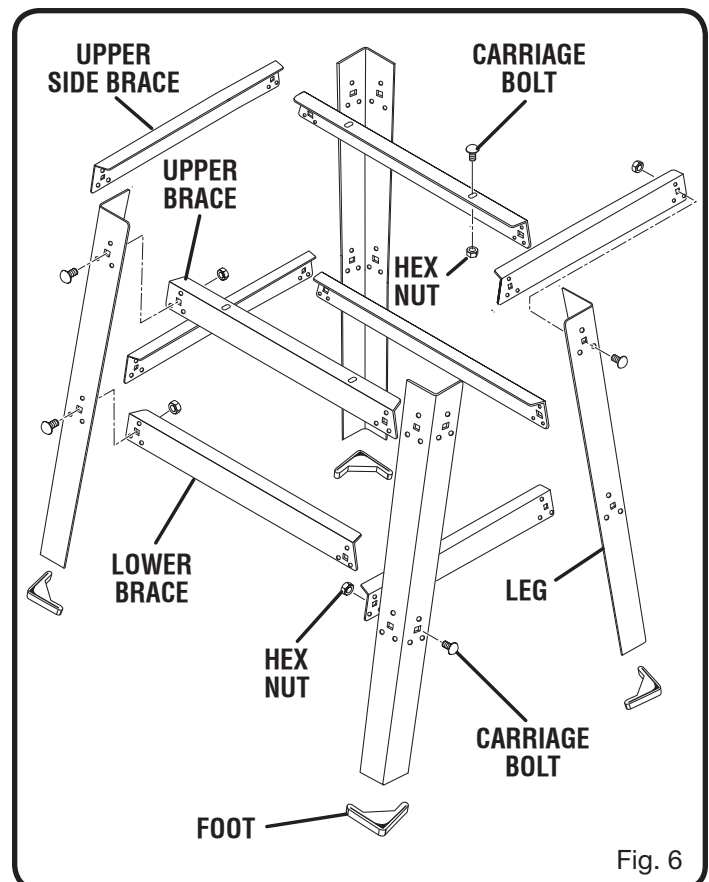

Fig. 6

ASSEMBLY

MOUNTING THE LEG STAND ON THE TABLE SAW BASE

See Figure 7.

Do not lift the saw without help. The saw base weighs approximately 42 lbs. Hold it close to your body. Keep your knees bent and lift with your legs, not your back. Ignoring these precautions can result in back injury.

- Take the following from a small hardware pack:

4 carriage bolts (1/4-20 x 1-5/8 in.)

4 hex nuts (1/4-20)

NOTE: This hardware was in the pack with hardware for assembling the leg stand and leveling feet.

- Place the leg stand on the table saw base. Align the holes in the table with the holes in the end braces.
- Place a bolt in each hole. Secure with a hex nut. Hand tighten.
- Repeat for three remaining holes. Tighten all hardware securely.

MOUNTING HOLES

The table saw must be mounted to a firm supporting surface such as a workbench or leg stand. Four bolt holes have been provided in the saw's base for this purpose. Each of the four mounting holes should be bolted securely using 3/8 in. machine bolts, lock washers, and hex nuts. Bolts should be of sufficient length to accommodate the saw base, lock washers, hex nuts, and the thickness of the workbench. Tighten all four bolts securely.

Carefully check the workbench after mounting to make sure that no movement can occur during use. If any tipping, sliding, or walking is noted, secure the workbench to the floor before operating.

TO INSTALL THE BLADE ADJUSTING HANDLE

See Figure 8.

The blade adjusting handle mounts to the height adjusting handwheel with a shoulder bolt, washer, and lock nut.

- Insert the shoulder bolt in the center of the blade adjusting handle. Place the washer over the bolt and insert into the hole in the blade adjusting handle.
- Place the lock nut behind the blade adjusting handle, and thread the shoulder bolt into the lock nut.
- Holding the nut in place, tighten with a screwdriver.

TO INSTALL THE LOCKING HANDLE

See Figure 9.

- Slide the locking handle over the exposed end of the rip fence making certain the handle is inserted as far as possible.
- Align the hole in the rip fence and the hole in the handle. Secure using the screw.

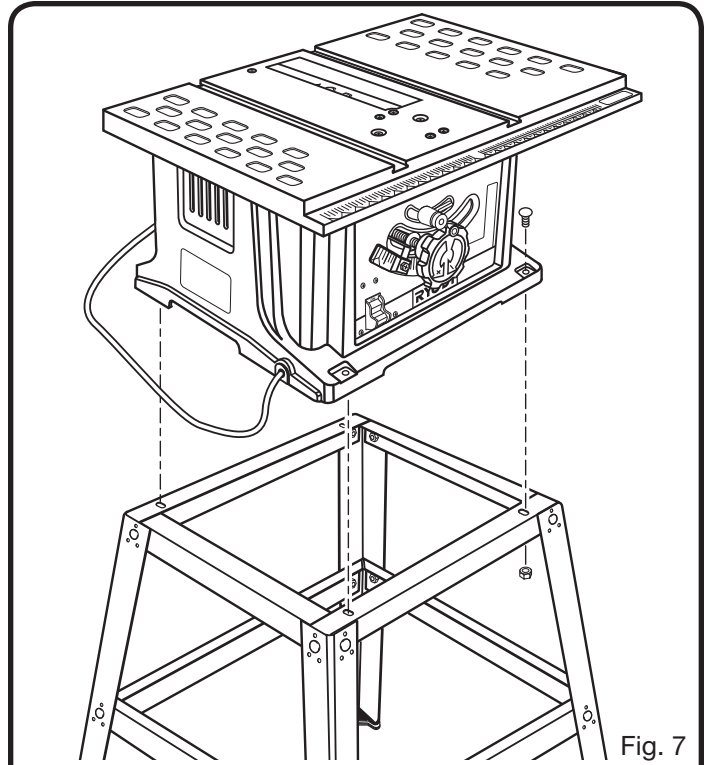

Fig. 7

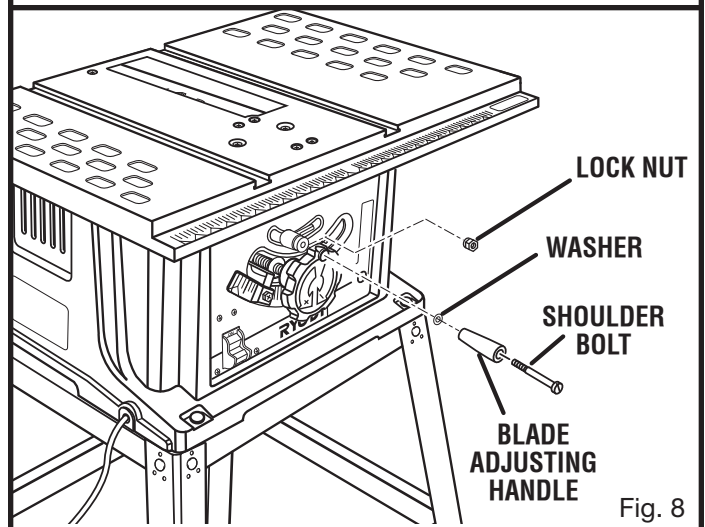

Fig. 8

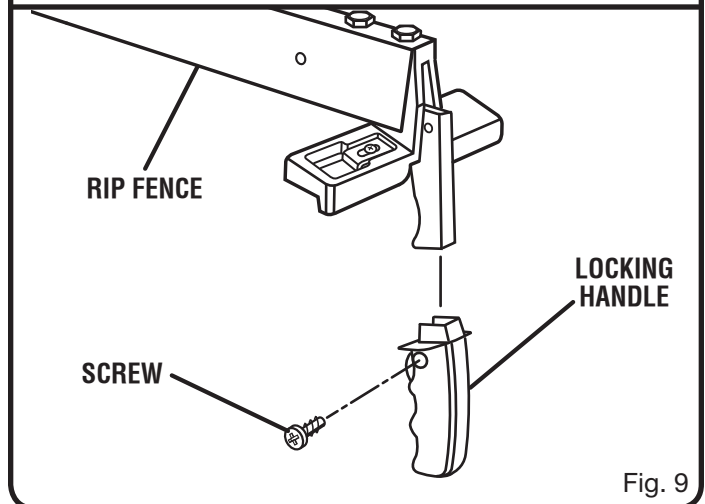

Fig. 9

ASSEMBLY

TO REMOVE/REPLACE THE THROAT PLATE

See Figure 10.

- Lower the blade by turning the blade adjusting handle clockwise.
- Loosen the screws in the throat plate.
- Lift the throat plate and spacers from the saw.
- To reinstall the throat plate, place the spacers of the holes and align the holes in the throat plate with the holes in the saw housing.
- Retighten the screws, being careful not to overtighten, which can cause the throat plate to bow or bend.

TO CHECK SAW BLADE INSTALLATION

See Figures 11 - 12.

To check the saw blade:

- Lower the blade by turning the blade adjusting handle clockwise.
- Remove the throat plate.
- Push the bevel lock lever to the right to lock the blade angle in place.

NOTE: If the bevel lock lever needs to be tightened further, pull the spring-loaded lever out and rotate it back to the left. Release the lever allowing it to seat itself then push it to the right until it is tightened securely.

To loosen the blade:

- Raise the blade to its full height by turning the blade adjusting handle counterclockwise.
- To keep blade arbor from rotating, place the open ended wrench on flats located on the left side of the blade.
- Place the second wrench over the arbor nut located on the right side of the blade. Turn nut counterclockwise to loosen.

To tighten the blade:

- Raise the blade to its full height by turning the blade adjusting handle counterclockwise.
- To keep blade arbor from rotating, place the open ended wrench on flats located on the left side of the blade.
- Place the second wrench over the arbor nut located on the right side of the blade. Turn nut clockwise to loosen.

NOTE: Arbor shaft has right-hand threads.

Check all clearances for free blade rotation.

- Lower the blade by turning the blade adjusting handle clockwise.
- Reinstall the throat plate.

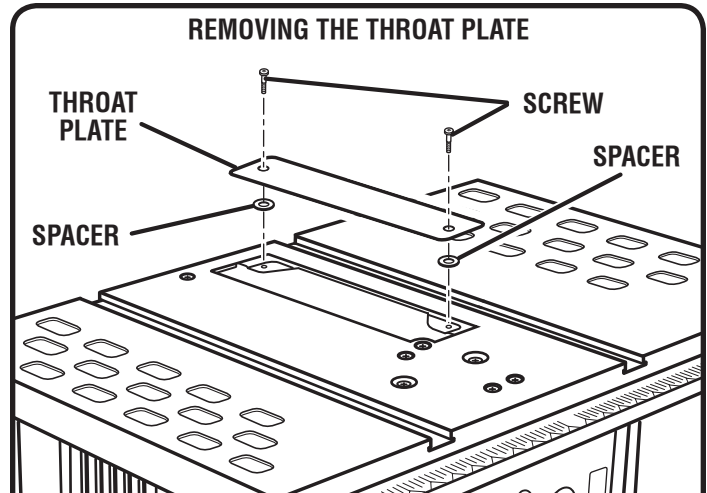

Fig. 10

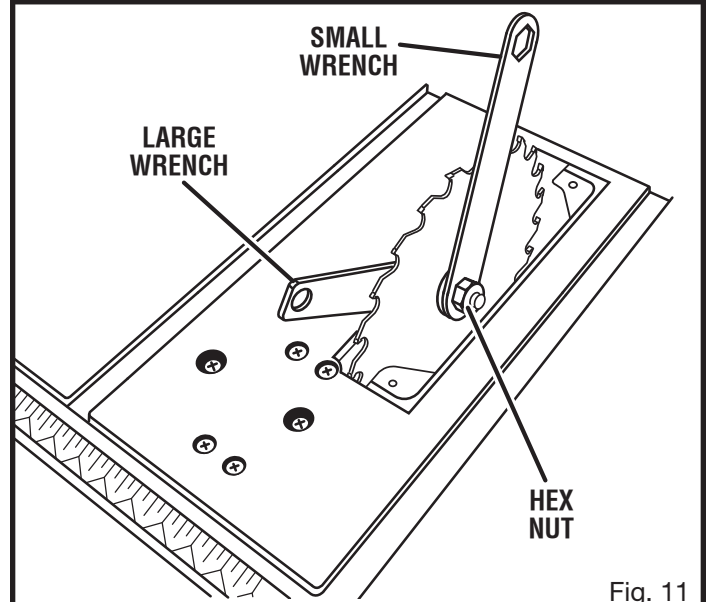

Fig. 11

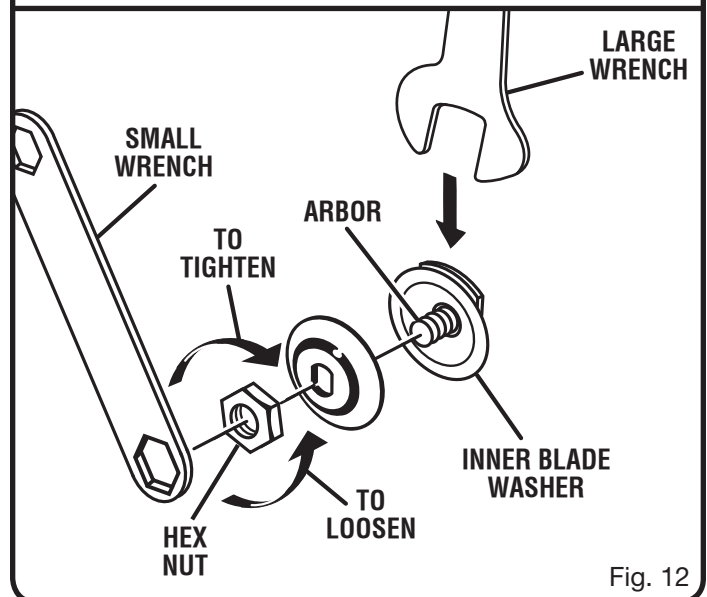

Fig. 12

ASSEMBLY

WARNING:

It is important to install and adjust the blade guard assembly correctly. Poor alignment could cause kickback and throw the workpiece at the operator.

WARNING:

Do not loosen the screws holding the spreader to the blade guard assembly. Unsecured pawls or spreader could cause personal injury while making adjustments.

TO INSTALL BLADE GUARD ASSEMBLY

See Figure 13.

- Lower the blade by turning the blade adjusting handle clockwise.
- Feed an external tooth lock washer, flat washer, and internal tooth lock washer on the socket head bolt then slide the bolt and washers into the hole in the mounting bracket.
- Slide the mounting bracket into the back of the saw over the rod and tighten the socket head bolt using the hex key provided.

NOTE: Before tightening the bolt, be sure there is at least 1/8 in. between the blade and the spreader.

- Securely tighten the bolt using the hex key provided.
- Attach the blade guard assembly to the mounting bracket using the socket head cap screws, flat washers, and external tooth lock washers as shown in figure 13.

The blade guard assembly must be aligned with the saw blade. See the following section for instructions.

TO CHECK AND ALIGN THE SAW BLADE AND BLADE GUARD ASSEMBLY

See Figure 14.

This saw has been adjusted at the factory and, unless damaged in shipping, should not require adjustments during assembly. After extensive use, it may need to be checked. If the blade guard assembly is out of alignment with the saw blade, adjust the alignment of the blade guard assembly.

The spreader must be aligned with the saw blade.

To check alignment of the spreader:

- Raise the saw blade by turning the blade adjusting handle counterclockwise.
- Place a framing square or straight edge beside the saw blade on the left.

If the spreader and saw blade are not in alignment, adjustment is needed. To adjust:

- Unplug the saw then raise the blade guard assembly.
- Loosen the socket head cap screws holding the blade guard assembly to the mounting bracket.

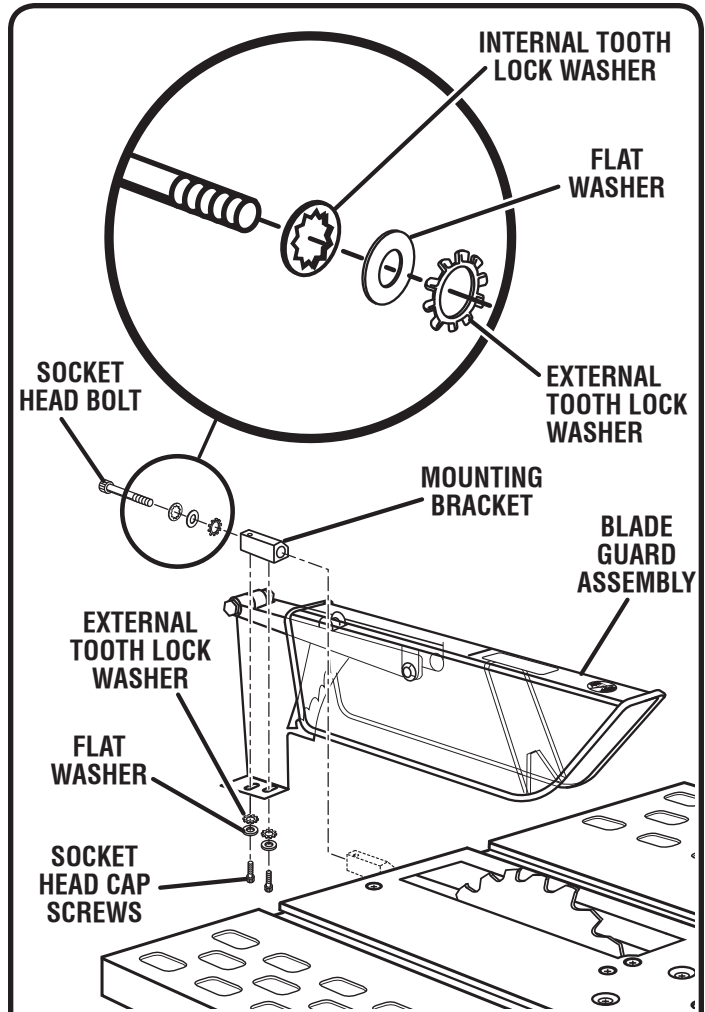

Fig. 13

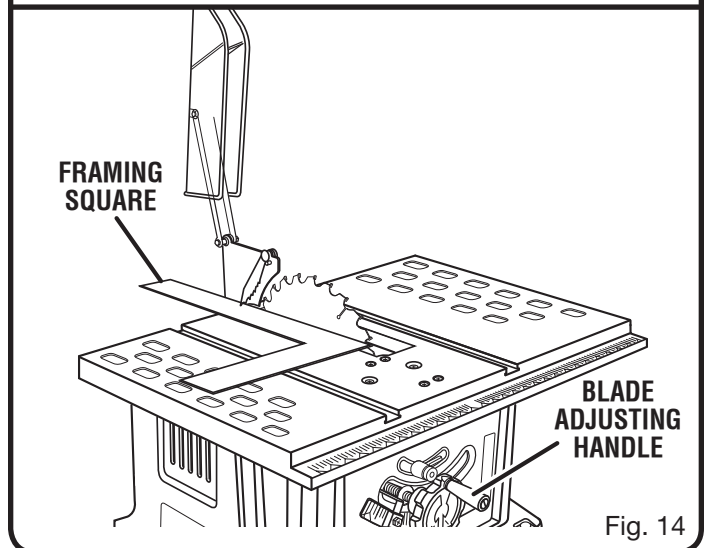

Fig. 14

- Reposition the blade guard assembly left or right as needed to align the spreader with the saw blade.
- Once properly aligned, securely retighten the screws.

OPERATION

⚠ WARNING:

Do not allow familiarity with tools to make you careless. Remember that a careless fraction of a second is sufficient to inflict serious injury.

⚠ WARNING:

Always wear safety goggles or safety glasses with side shields when operating power tools. Failure to do so could result in objects being thrown into your eyes resulting in possible serious injury.

⚠ WARNING:

Do not use any attachments or accessories not recommended by the manufacturer of this tool. The use of attachments or accessories not recommended can result in serious personal injury.

APPLICATIONS

You may use this tool for the purposes listed below:

- Straight line cutting operations such as cross cutting, ripping, mitering, beveling, and compound cutting.
- Cabinet making and woodworking.

NOTE: This table saw is designed to cut wood and wood composition products only.

BASIC OPERATION OF THE TABLE SAW

The 3-prong plug must be plugged into a matching outlet that is properly installed and grounded according to all local codes and ordinances. Improper connection of the equipment can result in electric shock. Do not modify the plug if it will not fit the outlet. Have the correct outlet installed by a qualified electrician. Refer to the *Electrical* section of this manual.

CAUSES OF KICKBACK

Kickback can occur when the blade stalls or binds, kicking the workpiece back toward you with great force and speed. If your hands are near the saw blade, they may be jerked loose from the workpiece and may contact the blade. Obviously, kickback can cause serious injury, and it is well worth using precautions to avoid the risks.

Kickback can be caused by any action that pinches the blade in the wood, such as the following:

- Making a cut with incorrect blade depth
- Sawing into knots or nails in the workpiece
- Twisting the wood while making a cut
- Failing to support work
- Forcing a cut
- Cutting warped or wet lumber
- Using the wrong blade for the type of cut

- Not following correct operating procedures
- Misusing the saw
- Failing to use the anti-kickback pawls
- Cutting with a dull, gummed-up, or improperly set blade

AVOIDING KICKBACK

- Always use the correct blade depth setting. The top of the blade teeth should clear the workpiece by 1/8 in. to 1/4 in.
- Inspect the work for knots or nails before beginning a cut. Knock out any loose knots with a hammer. Never saw into a loose knot or nail.
- Always use the rip fence when rip cutting and the miter gauge when cross cutting. This helps prevent twisting the wood in the cut. Never use both for the same operation.
- Always use clean, sharp, and properly-set blades. Never make cuts with dull blades.
- To avoid pinching the blade, support the work properly before beginning a cut.
- When making a cut, use steady, even pressure. Never force cuts.
- Do not cut wet or warped lumber.
- Always hold your workpiece firmly with both hands or with push sticks. Keep your body in a balanced position to be ready to resist kickback should it occur. Never stand directly in line with the blade.
- Use the right type of blade for the cut being made.

CUTTING AIDS

See Figure 15.

Push sticks are devices used for safely pushing a workpiece through the blade instead of using your hands. They can be made in various sizes and shapes from scrap wood to use in a specific project. The stick must be narrower than the workpiece, with a 90° notch in one end and shaping for a grip on the other end.

A push block has a handle fastened by recessed screws from the underside. Use it on non-through cuts.

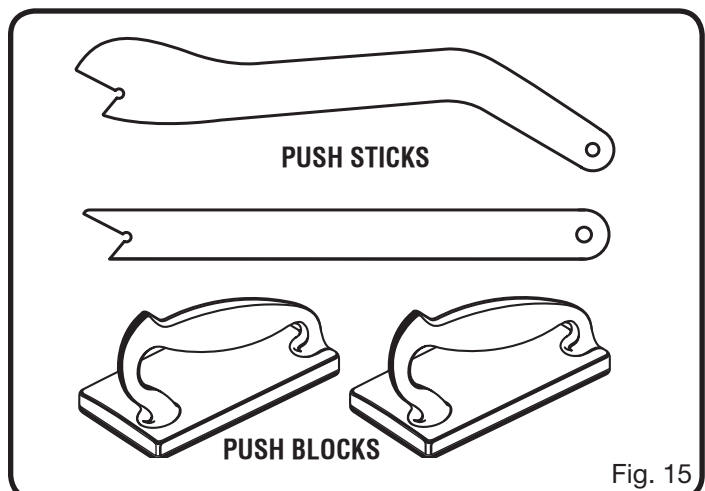

Fig. 15

OPERATION

TYPES OF CUTS

See Figure 16.

There are six basic cuts: 1) the cross cut, 2) the rip cut, 3) the miter cut, 4) the bevel cross cut, 5) the bevel rip cut, and 6) the compound (bevel) miter cut. All other cuts are combinations of these basic six. Operating procedures for making each kind of cut are given later in this section.

WARNING:

Always make sure the blade guard and anti-kickback pawls are in place and working properly when making these cuts to avoid possible injury.

Cross cuts are straight 90° cuts made across the grain of the workpiece. The wood is fed into the cut at a 90° angle to the blade, and the blade is vertical.

Rip cuts are made with the grain of the wood. To avoid kickback while making a rip cut, make sure one side of the wood rides firmly against the rip fence.

Miter cuts are made with the wood at any angle to the blade other than 90°. The blade is vertical. Miter cuts tend to “creep” during cutting. This can be controlled by holding the workpiece securely against the miter gauge.

WARNING:

Always use a push stick with small pieces of wood, and also to finish the cut when ripping a long narrow piece of wood, to prevent your hands from getting close to the blade.

Bevel cuts are made with an angled blade. Bevel cross cuts are across the wood grain, and bevel rip cuts are with the grain. The rip fence must always be on the right side of the blade for bevel rip cuts.

Compound (or bevel) miter cuts are made with an angled blade on wood that is angled to the blade. Be thoroughly familiar with making cross cuts, rip cuts, bevel cuts, and miter cuts before trying a compound miter cut.

CUTTING TIPS

Rabbet cuts are non-through cuts which can be either rip cuts or cross cuts. Carefully read and understand all sections of this operator’s manual before attempting any operation.

WARNING:

Do not use blades rated less than the speed of this tool. Failure to heed this warning could result in personal injury.

- The kerf (the cut made by the blade in the wood) will be wider than the blade to avoid overheating or binding. Make allowance for the kerf when measuring wood.

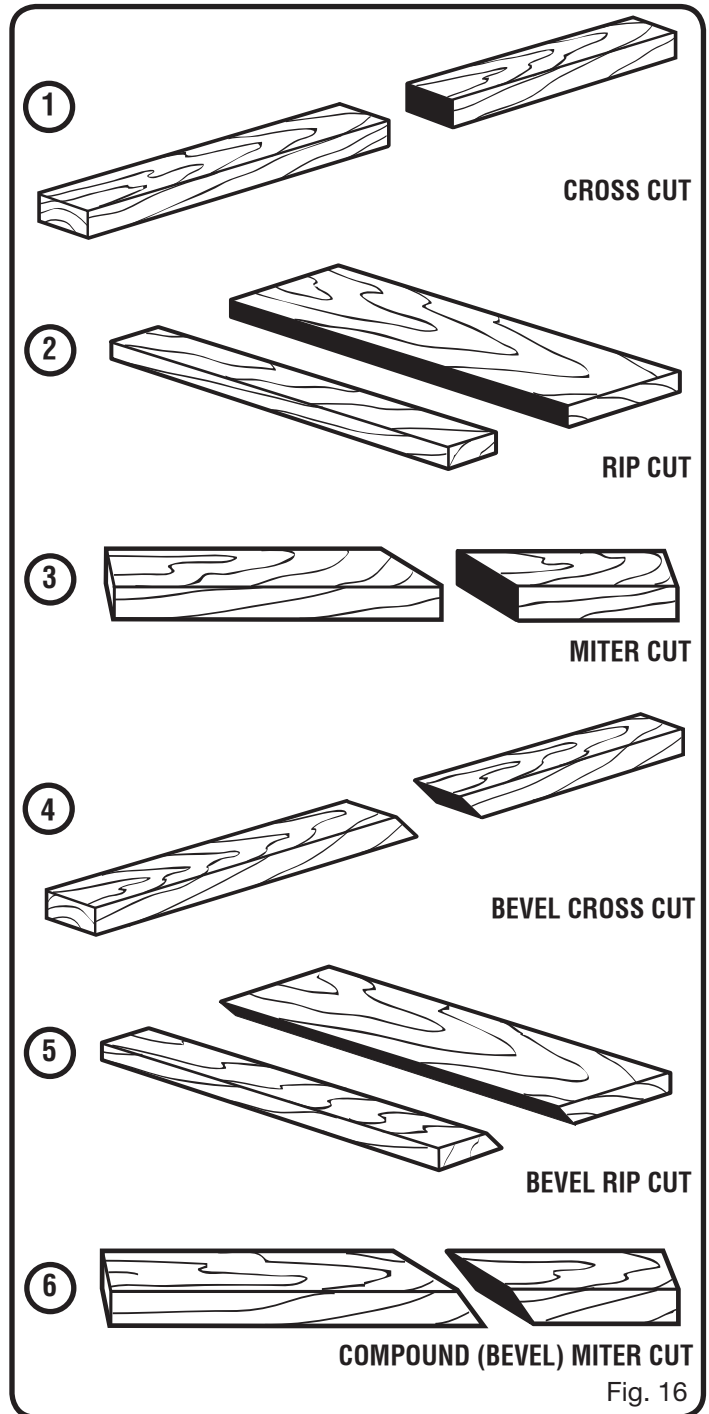

- Make sure the kerf is made on the waste side of the measuring line.
- Cut the wood with the finish side up.
- Knock out any loose knots with a hammer before making the cut.
- Always provide proper support for the wood as it comes out of the saw.

OPERATION

FEATHERBOARD

A featherboard is a device used to help control the workpiece by guiding it securely against the table or rip fence. Featherboards are especially useful when ripping small workpieces and for completing non-through cuts. The end is angled, with a number of short kerfs to give a friction hold on the workpiece. Lock it in place on the table with a C-clamp. Test that it can resist kickback by restricting the forward motion of the workpiece.

⚠ WARNING:

Place the featherboard against the uncut portion of the workpiece, to avoid kickback that could cause serious personal injury.

HOW TO MAKE A FEATHERBOARD

See Figure 17.

The featherboard is an excellent project for this saw. Select a solid, knot-free piece of lumber approximately 3/4 in. thick, 3-5/8 in. wide and 18 in. long. Mark the center of the width on one end of the stock. Miter one-half of the width to 30° and miter the other half of the same end to 45°. See page 26 for information on miter cuts. Mark the board from the point at 6 in. Prepare the saw for ripping as discussed on page 26. Set the rip fence to allow approximately a 1/4 in. "finger" to be cut in the stock. Feed the stock only to the mark previously made at 6 in. Turn the saw OFF and allow the blade to completely stop rotating before removing the stock. Reset the rip fence and cut spaced rips into the workpiece to allow approximately 1/4 in. fingers and 1/8 in. spaces between the fingers.

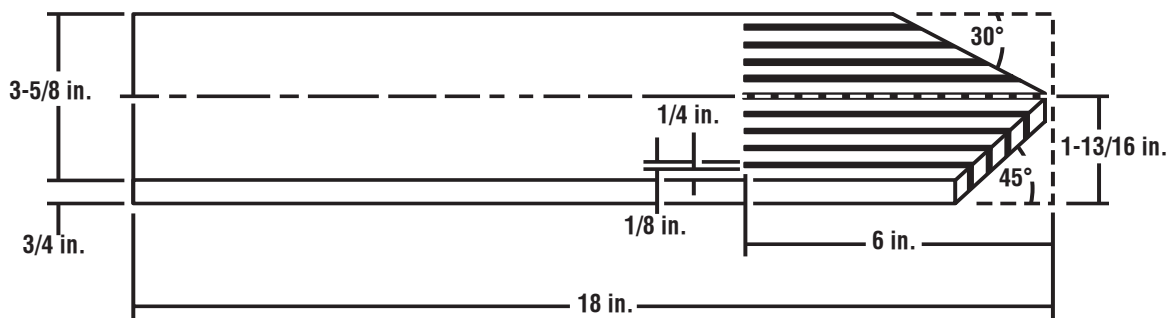

Fig. 17

HOW TO MOUNT A FEATHERBOARD

See Figure 18.

Completely lower the saw blade. Position the rip fence to the desired adjustment for the cut to be performed and lock the rip fence. Place the workpiece against the fence and over the saw blade area. Adjust the featherboard to apply resistance to the workpiece just forward of the blade. Attach a C-clamp to secure the featherboard to the edge of the saw table.

⚠ WARNING:

Do not locate the featherboard to the rear of the blade. Kickback can result from the featherboard pinching the workpiece and binding the blade in the saw kerf if positioned improperly. Failure to heed this warning can result in serious personal injury.

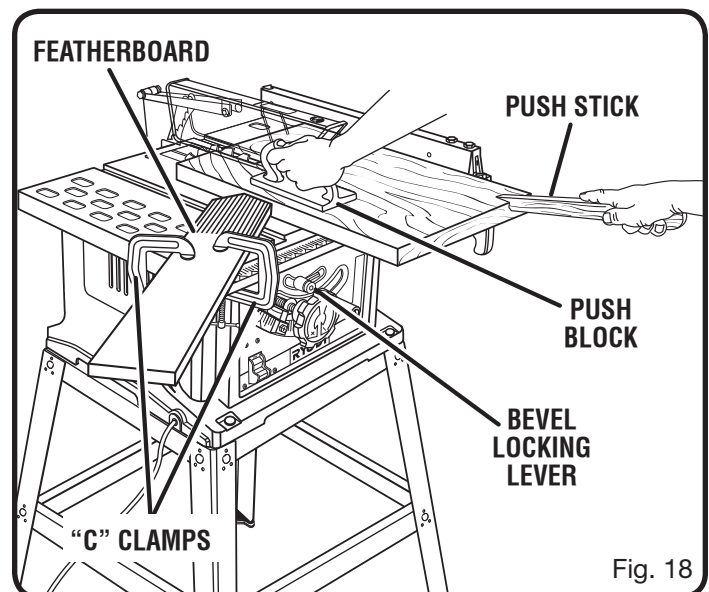

Fig. 18

OPERATION

TO CHANGE THE BLADE DEPTH

See Figure 19.

The blade depth should be set so that the outer tips of the blade are higher than the workpiece by approximately 1/8 in. to 1/4 in. but the lowest points (gullets) are below the top surface. Raise the blade by turning the blade adjusting handle counterclockwise or lower it by turning the handle clockwise.

TO CHANGE BEVEL ANGLE

See Figure 20.

A 90° cut has a 0° bevel and a 45° cut has a 45° bevel.

- Unplug the saw.
- Loosen bevel control by turning bevel lock lever all the way to the left. If it needs to be further loosened, pull spring-loaded bevel lock lever out and rotate it back to the right. Release bevel locking lever and allow it to seat (lock) in its original position. Turn it to the left again until loose.
- Adjust the bevel angle by sliding the blade adjusting handle left or right to the desired angle.
- Tighten bevel control by turning bevel lock lever to the right. If it needs to be tightened more, pull the spring-loaded bevel lock lever out and rotate it to the left. Then release bevel lock lever and allow it to return to its original position. Rotate to the right again. Repeat this process until bevel lock lever is securely tightened.

NOTE: Prior to making cuts, the bevel lock lever must be in the locked position as shown in figure 20.

TO ADJUST THE BEVEL INDICATOR

See Figure 21.

If the bevel indicator is not at zero when the saw blade is at 90°, adjust the indicator by loosening the screw and setting it at 0° on the bevel scale. Retighten the screw.

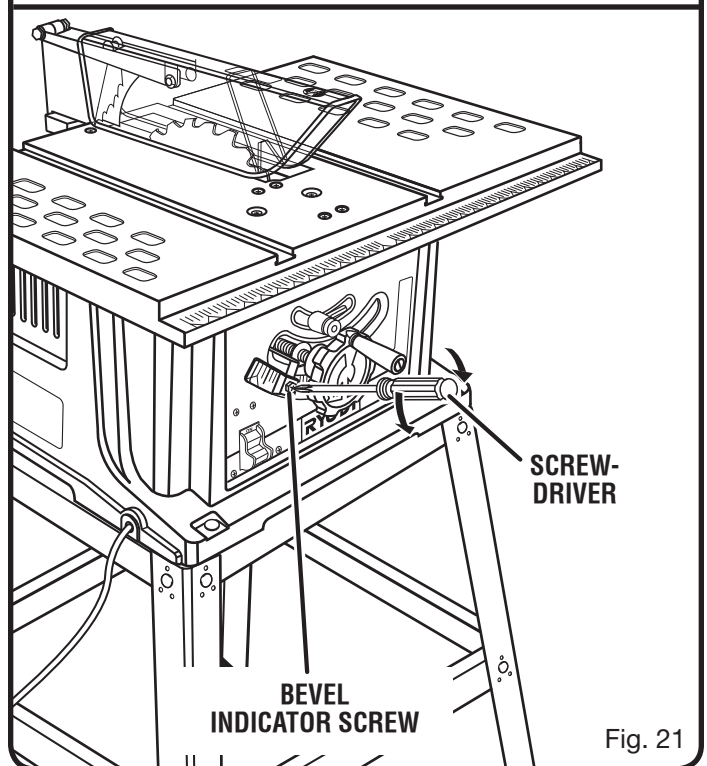
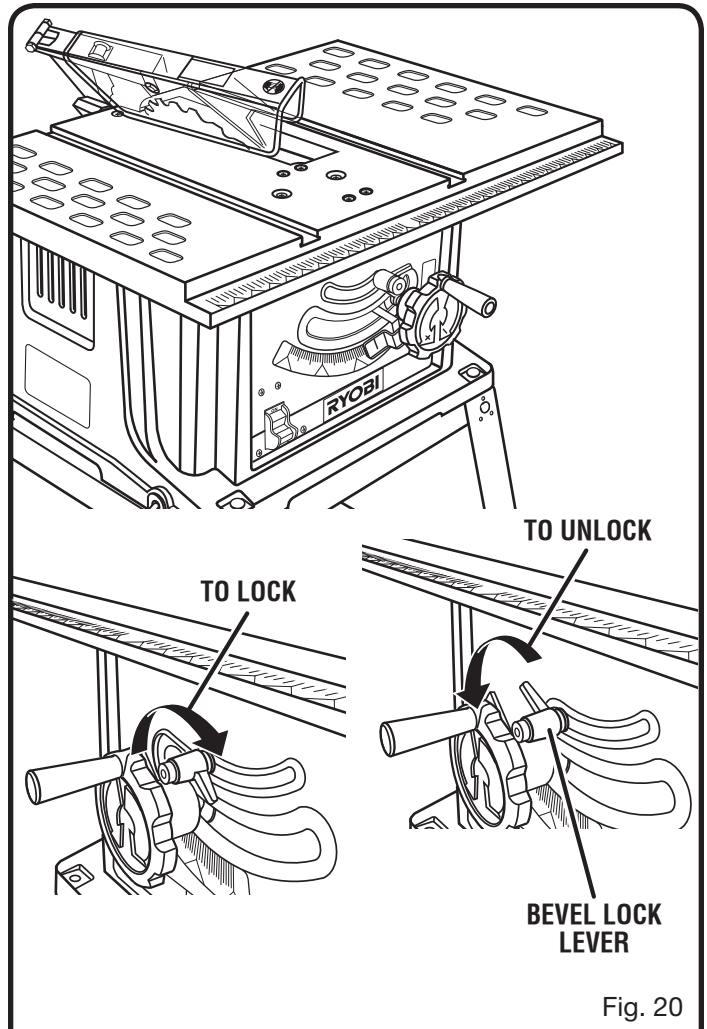
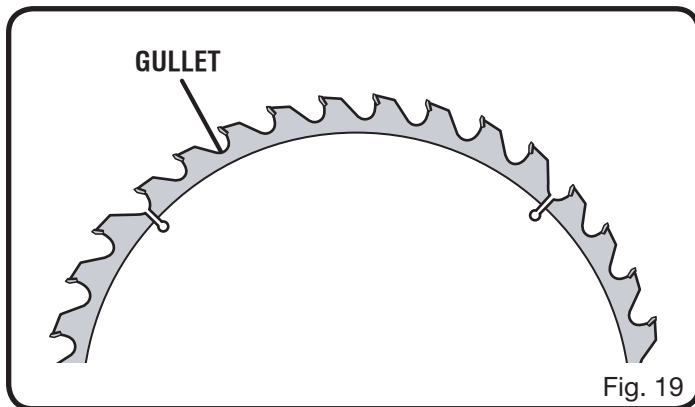

OPERATION

WARNING:

To reduce the risk of injury, always make sure the rip fence is parallel to the blade before beginning any operation.

TO INSTALL THE RIP FENCE

See Figure 22.

- Place the rear lip on the rear of the saw table and pull slightly toward the front of the unit.
- Lower the front end of the rip fence onto the guide surfaces on top of the front rail.
- Push the rip fence lever down to automatically align and secure the fence. The trigger lock must engage.

Check for a smooth gliding action. If adjustments are needed, see **To Check the Alignment of the Rip Fence to the Blade** in the *Adjustment* section of this manual.

TO SET THE RIP FENCE SCALE INDICATOR TO THE BLADE

See Figure 23.

Beginning with the blade at a 0° angle (straight up), use the following steps to set the rip fence scale indicator to the blade:

- Unplug the saw.
- Loosen the rip fence by depressing the trigger lock and lifting the locking handle.
- Using a framing square, set the rip fence 2 in. from the blade tip edge.
- Loosen the screw for the scale indicator and align with the 2 in. mark as shown.
- Retighten the screw.

TO USE THE MITER GAUGE

See Figure 24.

The miter gauge provides greater accuracy in angled cuts. For very close tolerances, test cuts are recommended.

There are two miter gauge channels, one on either side of the blade. When making a 90° cross cut, you can use either miter gauge channel. When making a beveled cross cut (the blade tilted in relation to the table) the miter gauge should be located in the slot on the right so that the blade is tilted away from the miter gauge and your hands.

The miter gauge can be turned 60° to the right or left.

- Loosen the lock knob.
- With the miter gauge in the miter gauge slot, rotate the gauge until the desired angle is reached on the scale.
- Retighten the lock knob.

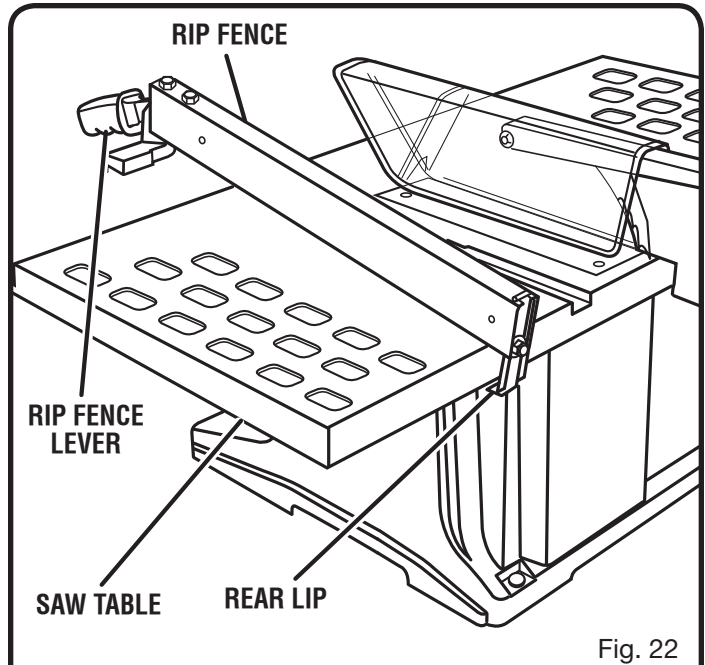

Fig. 22

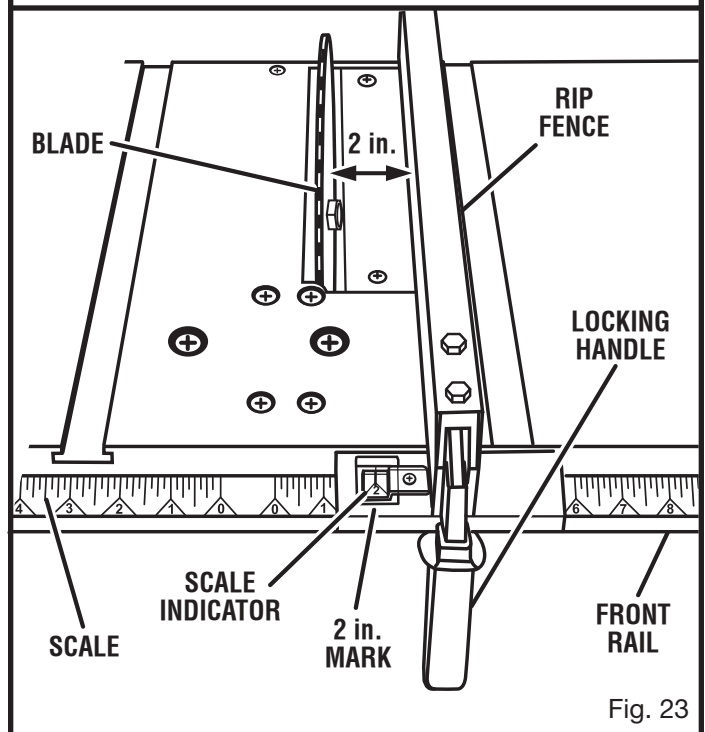

Fig. 23

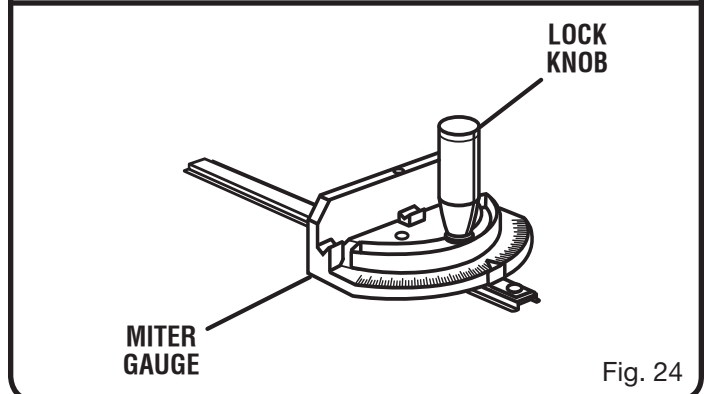

Fig. 24

OPERATION

MAKING CUTS

The blade provided with the saw is a high-quality combination blade suitable for ripping and cross cut operations. Carefully check all setups and rotate the blade one full revolution to assure proper clearance before connecting to a power source.

WARNING:

Do not use blades rated less than the speed of this tool. Failure to heed this warning could result in personal injury.

Use the miter gauge when making cross, miter, bevel, and compound miter cuts. To secure the angle, lock the miter gauge in place by twisting the lock knob clockwise. Always tighten the lock knob securely in place before use.

NOTE: It is recommended that you place the piece to be saved on the left side of the blade and that you make a test cut on scrap wood first.

TO MAKE A CROSS CUT

See Figures 25 - 26.

WARNING:

Using the rip fence as a cutoff gauge when cross cutting will result in kickback which can cause serious personal injury. Never use the rip fence for any purpose when cross cutting.

WARNING:

Make sure the blade guard assembly is installed and working properly to avoid serious personal injury.

- Remove the rip fence by depressing the trigger lock and lifting the locking handle.
- Turn the blade adjusting handle until the blade is set to the correct depth for the workpiece.
- Set the miter gauge to 0° and tighten the lock knob.
- Place a support (the same height as saw table) behind the saw for the cut work.
- Make sure the wood is clear of the blade before turning on the saw.
- Turn the saw **ON** by lifting the switch button.
- Let the blade build up to full speed before moving the workpiece into the blade.
- Hold the workpiece firmly against the miter gauge and feed the workpiece into the blade. Keep the workpiece flush against the miter gauge. Stand slightly to the side of the wood as it contacts the blade to reduce the chance of injury should kickback occur. Keep the miter gauge firmly against the saw table as the workpiece is fed into the blade.

NOTE: The hand closest to the blade should be placed on the miter gauge lock knob and the hand farthest from the blade should be placed on the miter gauge and the workpiece.

- When the cut is made, turn the saw **OFF**. Wait for the blade to come to a complete stop before removing any part of the workpiece.

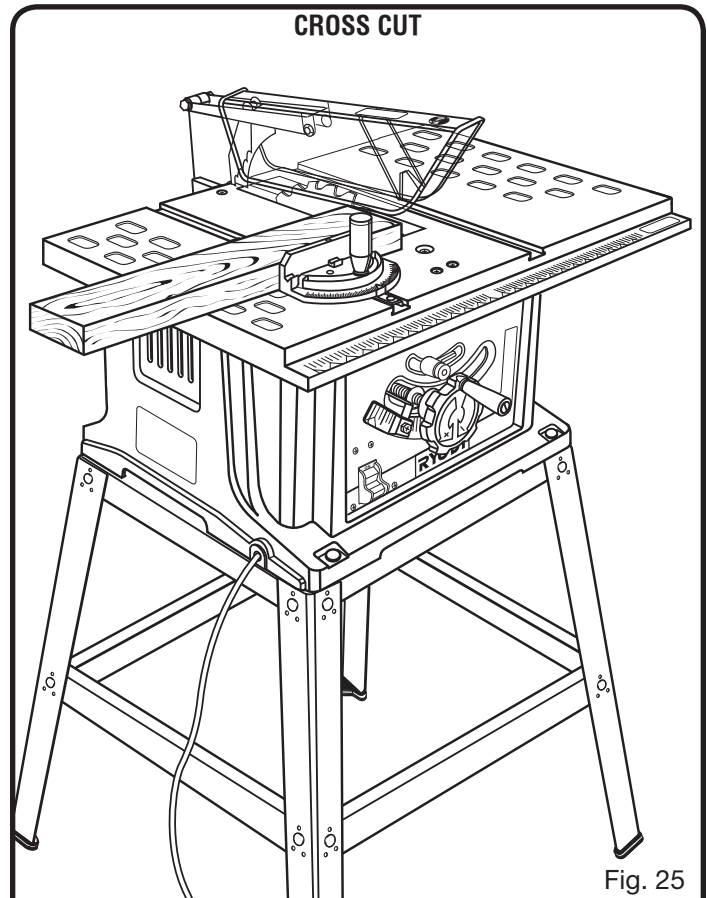

Fig. 25

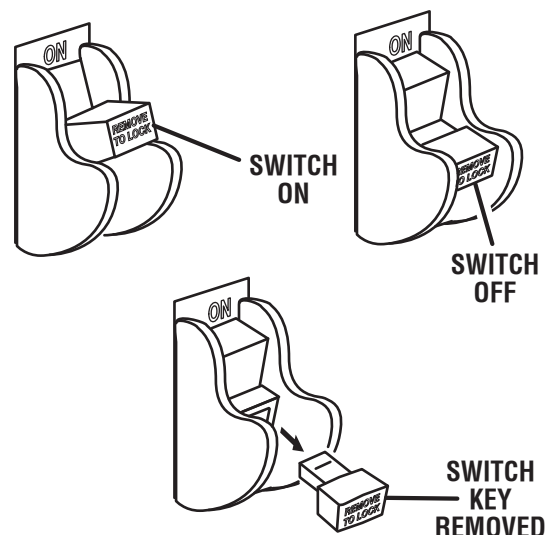

Fig. 26

OPERATION

TO MAKE A MITER CUT

See Figure 27.

WARNING:

Make sure the blade guard assembly is installed and working properly to avoid serious personal injury.

- Remove the rip fence by depressing the lock and lifting the locking handle.
- Turn the blade adjusting handle until the blade is set to the correct depth for the workpiece.
- Set the miter gauge to the desired angle and tighten the miter gauge lock knob.
- Place a support (the same height as saw table) behind the saw for the cut work.
- Make sure the wood is clear of the blade before turning on the saw.
- Turn the saw **ON** by lifting the switch button.
- Let the blade build up to full speed before moving the workpiece into the blade.
- Hold the workpiece firmly with both hands on the miter gauge and feed the workpiece into the blade. Keep the workpiece flush against the miter gauge. Stand slightly to the side of the wood as it contacts the blade to reduce the chance of injury should kickback occur.

NOTE: The hand closest to the blade should be placed on the miter gauge lock knob and the hand farthest from the blade should be placed on the workpiece.

- When the cut is made, turn the saw **OFF**. Wait for the blade to come to a complete stop before removing any part of the workpiece.

TO MAKE A RIP CUT

See Figure 28.

WARNING:

Make sure the blade guard assembly is installed and working properly to avoid serious personal injury.

- Remove the miter gauge by sliding it out of the miter gauge groove.
- Turn the blade adjusting handle until the blade is set to the correct depth for the workpiece.
- Position the rip fence the desired distance from the blade for the cut and securely lock the handle.
- Set the blade to 0°.
- Place a support (the same height as the saw table) behind the table saw for the cut work.
- Make sure the wood is clear of the blade before turning on the table saw.
- Turn the saw **ON**.

- Let the blade build up to full speed before feeding the workpiece into the blade.
- Use a push block or push stick to move the wood through the cut past the blade. **Never push a small piece of wood into the blade with your hand, always use a push stick.** The use of push blocks, push sticks, and featherboards are necessary when making non-through cuts.
- Stand to the side of the wood as it contacts the blade to reduce the chance of injury should kickback occur. Never stand directly in the line of cut.
- When the cut is made, turn the saw **OFF**. Wait for the blade to come to a complete stop before removing any part of the workpiece.

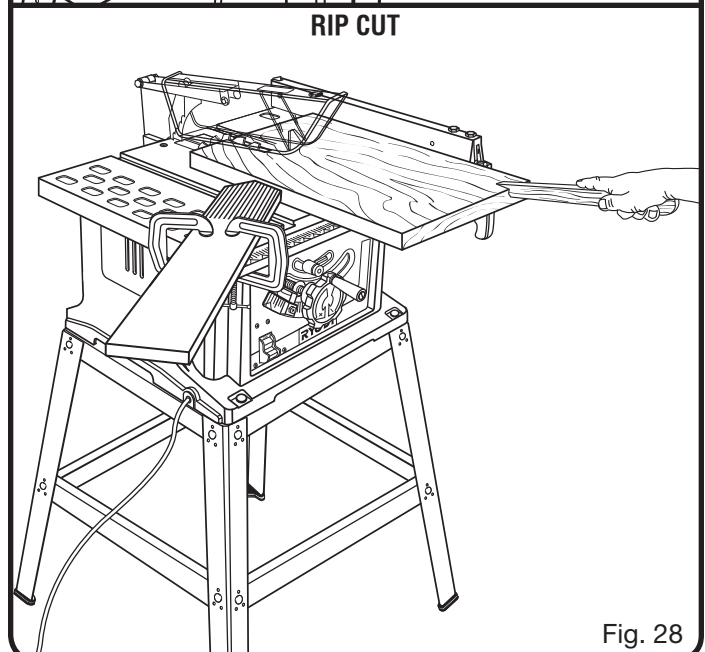
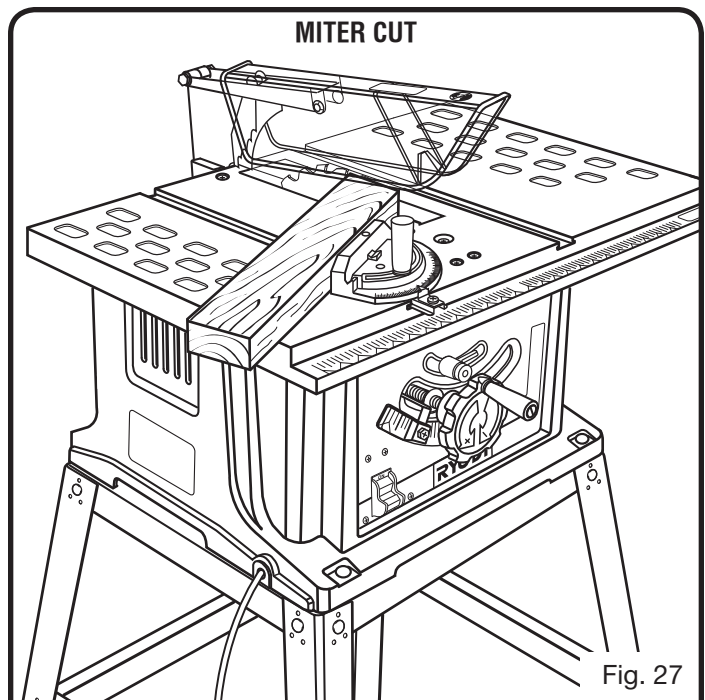

OPERATION

TO MAKE A BEVEL CROSS CUT

See Figure 29.

⚠ WARNING:

Make sure the blade guard assembly is installed and working properly to avoid serious personal injury.

- Remove the rip fence by depressing the lock and lifting the locking handle.
- Turn the bevel locking lever to the left to unlock it. Turn the blade adjusting handle until the bevel indicator is at the desired angle.
- Set the blade to the correct depth for the workpiece and retighten the bevel locking lever.
- Set the miter gauge at 90° and tighten the miter gauge lock knob.
- Place a support (the same height as saw table) behind the saw for the cut work.
- Make sure the wood is clear of the blade before turning on the saw.
- Turn the saw **ON**.
- Let the saw blade build up to full speed before moving the workpiece into the blade.
- Hold the workpiece firmly with both hands on the miter gauge and feed the workpiece into the blade. Keep the workpiece flush against the miter gauge. Stand slightly to the side of the wood as it contacts the blade to reduce the chance of injury should kickback occur.

NOTE: The hand closest to the blade should be placed on the miter gauge lock knob and the hand farthest from the blade should be placed on the workpiece.

- When the cut is made, turn the saw **OFF**. Wait for the blade to come to a complete stop before removing any part of the workpiece.

TO MAKE A BEVEL RIP CUT

See Figure 30.

⚠ WARNING:

When making a bevel rip cut, the rip fence must be on the right side of the blade to avoid trapping the wood and causing kickback. Placement of the rip fence to the left of the blade will result in kickback and the risk of serious personal injury.

⚠ WARNING:

Make sure the blade guard assembly is installed and working properly to avoid serious personal injury.

- Remove the miter gauge by sliding it out of the miter gauge groove.
- Turn the bevel locking lever to the left to unlock. Turn the blade adjusting handle until the bevel indicator is at the desired angle.
- Set the blade to the correct depth for the workpiece and push the bevel locking lever to the right to relock it.

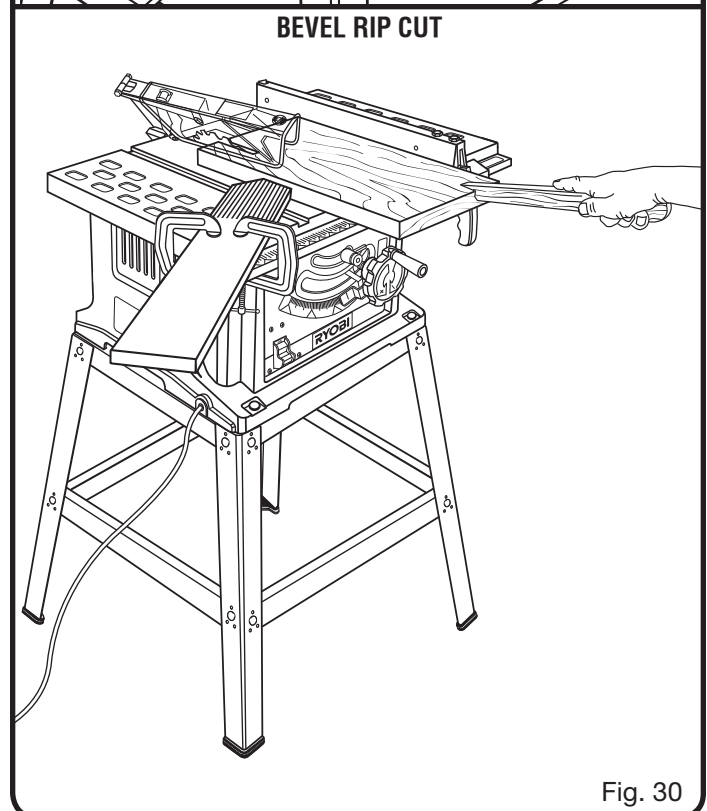
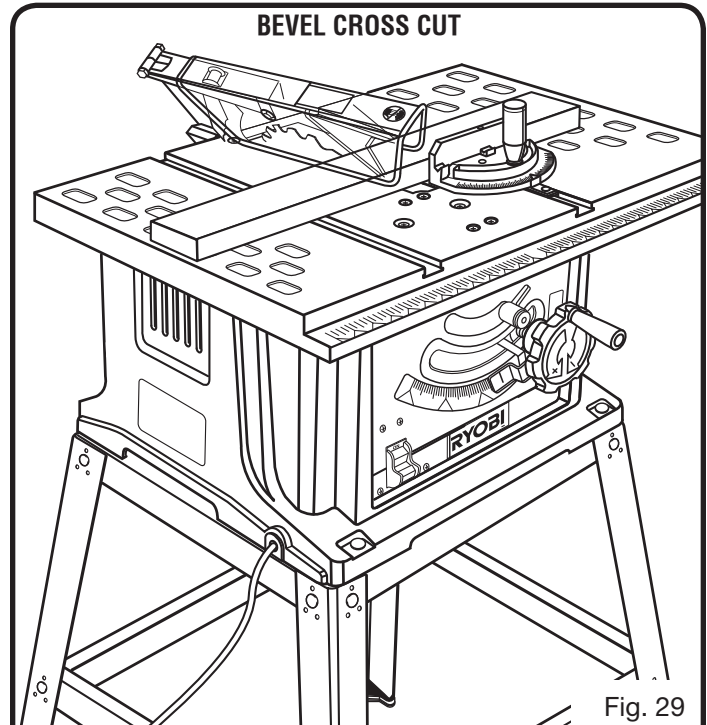

OPERATION

- Position the rip fence the desired distance from the right side of the blade and lock down the lever.
- Place a support the same height as the table surface behind the saw for the cut work.
- Make sure the wood is clear of the blade before turning on the saw.
- Turn the saw **ON**.
- Position the workpiece flat on the table with the edge flush against the rip fence. Let the blade build up to full speed before feeding the workpiece into the blade.
- Using a push stick and/or push blocks, slowly feed the workpiece toward the blade. Stand slightly to the side of the wood as it contacts the blade to reduce the chance of injury should kickback occur.
- Once the blade has made contact with the workpiece, use the hand closest to the rip fence to guide it. Make sure the edge of the workpiece remains in solid contact with both the rip fence and the surface of the table. If ripping a narrow piece, use a push stick to move the piece through the cut and past the blade.
- When the cut is made, turn the saw **OFF**. Wait for the blade to come to a complete stop before removing any part of the workpiece.
- After the blade has stopped completely, remove the cutoff stock.
- Grasp the workpiece from the lead end (the end fed into the blade first) and carefully remove it from the saw table.

TO MAKE A COMPOUND (BEVEL) MITER CUT

See Figure 31.

! WARNING:

Make sure the blade guard assembly is installed and working properly to avoid serious personal injury.

- Remove the rip fence by depressing the lock and lifting the locking handle.
- Turn the bevel locking lever to the left to unlock it. Turn the blade adjusting handle until the bevel indicator is at the desired angle.
- Retighten the bevel locking lever and set the blade to the correct depth for the workpiece.
- Set the miter gauge to desired angle and tighten the miter gauge lock knob.
- Make sure the wood is clear of the blade before turning on the saw.
- Turn the saw **ON**.

- Hold the workpiece firmly with both hands on the miter gauge and feed the workpiece into the blade.
NOTE: The hand closest to the blade should be placed on the miter gauge lock knob and the hand farthest from the blade should be placed on the miter gauge and workpiece.
- Keep the workpiece flush against the miter gauge. Stand slightly to the side of the wood as it contacts the blade to reduce the chance of injury should kickback occur.
- When the cut is made, turn the saw **OFF**. Wait for the blade to come to a complete stop before removing any part of the workpiece.
- After the blade has stopped completely, remove the cutoff stock.

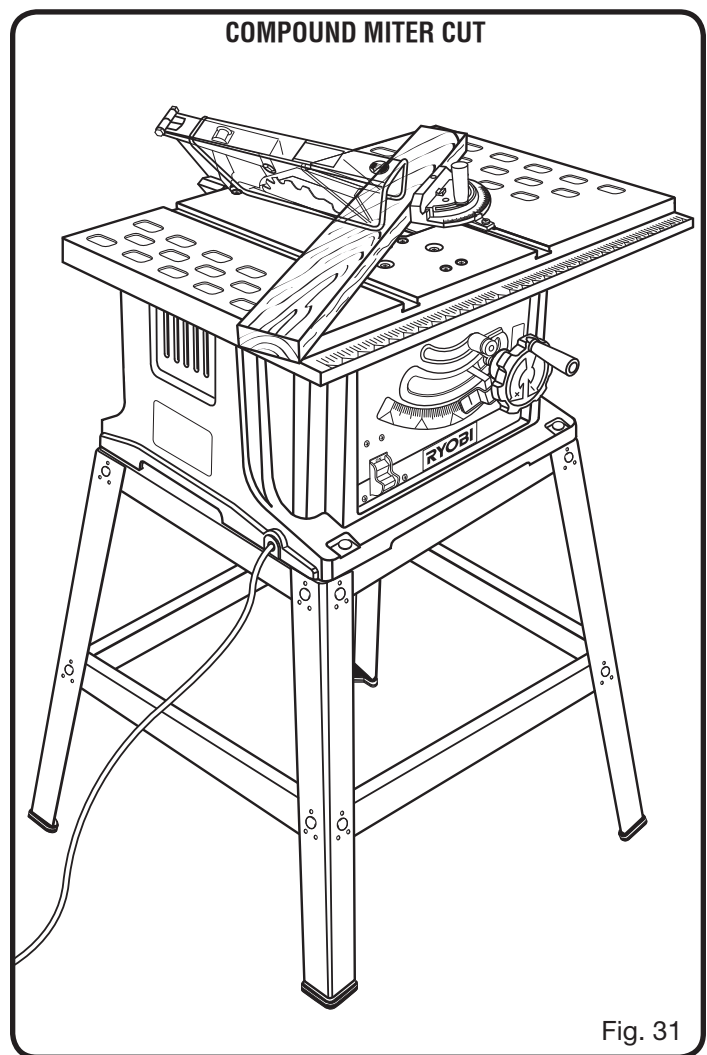

Fig. 31

OPERATION

TO MAKE A NON-THROUGH CUT

See Figure 32.

Non-through cuts can be made with the grain (ripping) or across the grain (cross cut). The use of a non-through cut is essential to cutting grooves. **DO NOT** perform bevel non-through cuts on this machine.

NOTE: This is the only type of cut that is made without the blade guard assembly installed. Make sure the blade guard assembly is reinstalled upon completion of this type of cut. **DO NOT** install dado blades on this machine.

Read the appropriate section which describes the type of cut in addition to this section on non-through cuts. For example, if your non-through cut is a straight cross cut, read and understand the section on straight cross cuts before proceeding.

WARNING:

When making a non-through cut, the cutter is covered by the workpiece during most of the cut. Be alert to the exposed cutter at the start and finish of every cut to avoid the risk of serious personal injury.

WARNING:

Never feed wood with your hands when making any non-through cut such as rabbets. To avoid personal injury, always use push blocks, push sticks, and featherboards.

- Unplug the saw.
- Remove the blade guard assembly by removing the two socket head cap screws, lock washers, and flat washers.
- Set the blade to 0°.
- Set the blade to the correct depth for the workpiece.
- Plug the saw into the power source.
- Turn the saw **ON**.
- Feed the workpiece into the blade.

NOTE: Always use push blocks, push sticks, and featherboards when making non-through cuts to avoid the risk of serious injury.

- When the cut is made, turn the saw **OFF**. Wait for the blade to come to a complete stop before removing any part of the workpiece.

Once all non-through cuts are complete:

- Unplug the saw.
- Lower the blade and reinstall the blade guard assembly using the two socket head cap screws, lock washers, and flat washers.

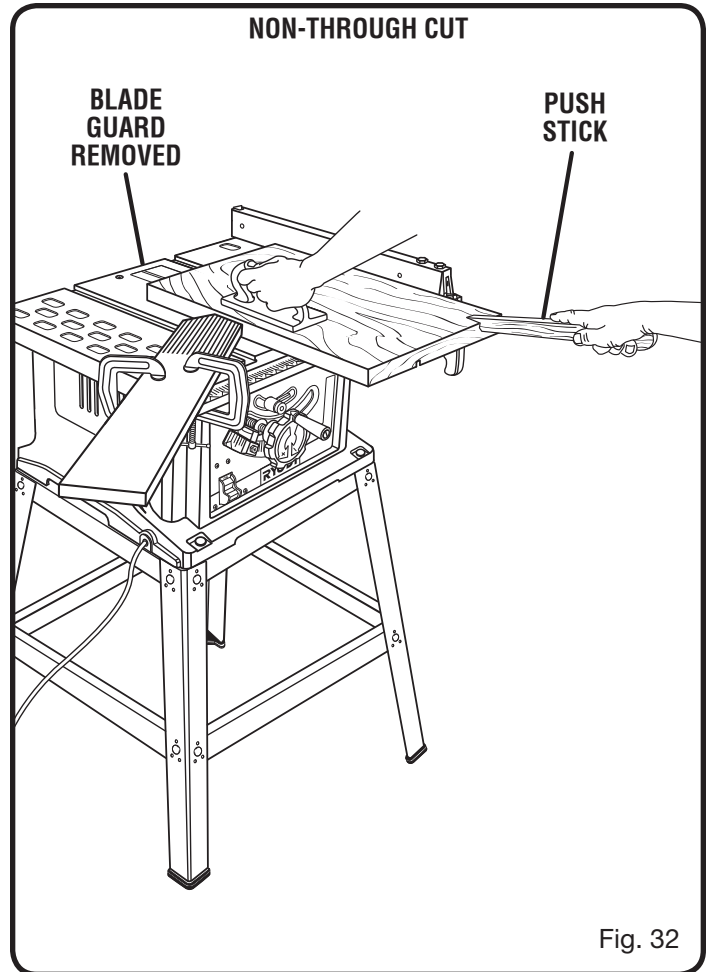

Fig. 32

ADJUSTMENTS

⚠ WARNING:

Before performing any adjustment, make sure the tool is unplugged from the power supply and the switch is in the OFF position. Failure to heed this warning could result in serious personal injury.

To avoid unnecessary setups and adjustments, a good practice is to check your setups carefully with a framing square and make practice cuts in scrap wood before making finish cuts in good workpieces. Do not start any adjustments until you have checked with a square and made test cuts to be sure adjustments are needed.

TO CHECK THE ALIGNMENT OF THE RIP FENCE TO THE BLADE

See Figure 33.

⚠ WARNING:

To reduce the risk of injury, always make sure the rip fence is parallel to the blade before beginning any operation.

- Unplug the saw then remove the blade guard assembly.
- Unlock the rip fence by depressing the trigger lock and lifting the locking handle.
- Place a framing square beside the blade and move the rip fence up to the square. Take the dimension on the rip scale.
- Move the rip fence back and turn the framing square 180° to check the other side.
- If the two dimensions are not the same, loosen the two screws on the fence and align it.
- Retighten the two screws.
- Make two or three test cuts on scrap wood. If the cuts are not true, repeat the process.

NOTE: The rip fence must be secure when the locking handle is engaged. The clamp screw on the rear of the rip fence is tightened by turning clockwise to increase tightness of the rear of the rip fence.

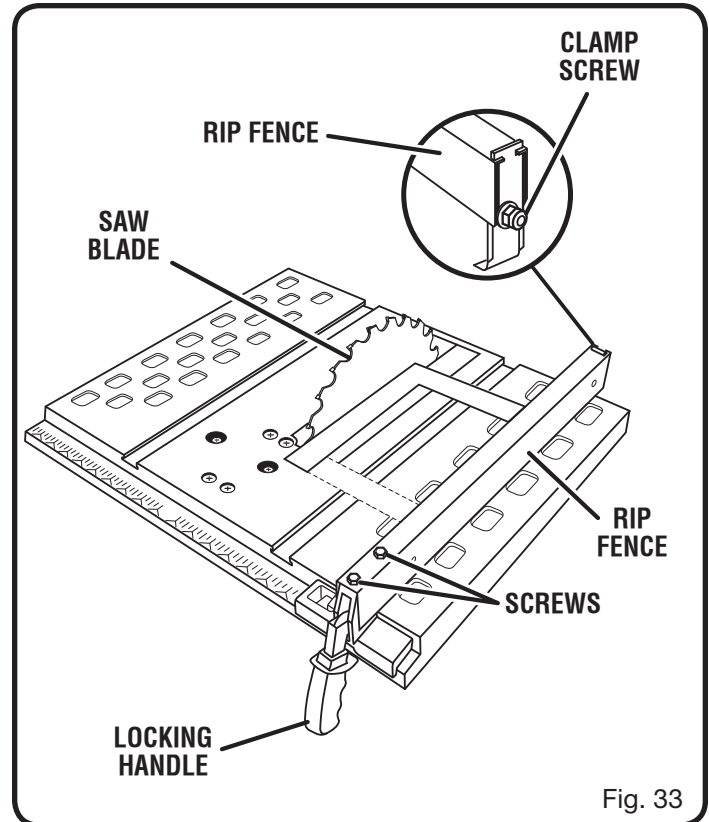

Fig. 33

ADJUSTMENTS

TO SET THE 90° POSITIVE STOP

See Figure 34.

Make sure the saw is unplugged from the power source. Raise the blade to the maximum height by turning the blade adjusting handle counterclockwise. Unlock the bevel locking lever.

If the blade angle is less than 90°, turn the 90° positive stop adjustment screw counterclockwise one turn. Rotate blade adjusting handle counterclockwise until it stops. Recheck the blade position. Continue this process until the blade is at 90°. Relock the bevel locking lever.

If the blade angle is greater than 90°, use the framing square to position the blade to 90°. Turn the 90° positive stop adjustment screw clockwise until it stops. Relock the bevel locking lever.

Reset the bevel indicator to 0° by loosening the screw holding the indicator. Line up the red line on the indicator with the 0° mark on the bevel scale.

TO SET THE 45° POSITIVE STOP

See Figure 35.

Make sure the saw is unplugged from the power source. Raise the blade to the maximum height by turning the blade adjusting handle counterclockwise. Turn the bevel locking lever to the left to loosen the bevel.

If the blade angle is greater than 45°, turn the 45° positive stop adjustment screw counterclockwise 1 turn and rotate the bevel adjusting handle counterclockwise until it stops. Recheck the blade position. Continue this process until the blade is at 45°. Tighten the bevel locking lever.

If the blade angle is less than 45°, use the combination square or triangle to position the blade at 45°. Turn the 45° positive stop adjustment screw clockwise until it stops. Tighten the bevel locking lever.

Reset the bevel indicator to 45° by loosening the screw holding the indicator. Line up the red line on the indicator with the 45° mark on the bevel scale.

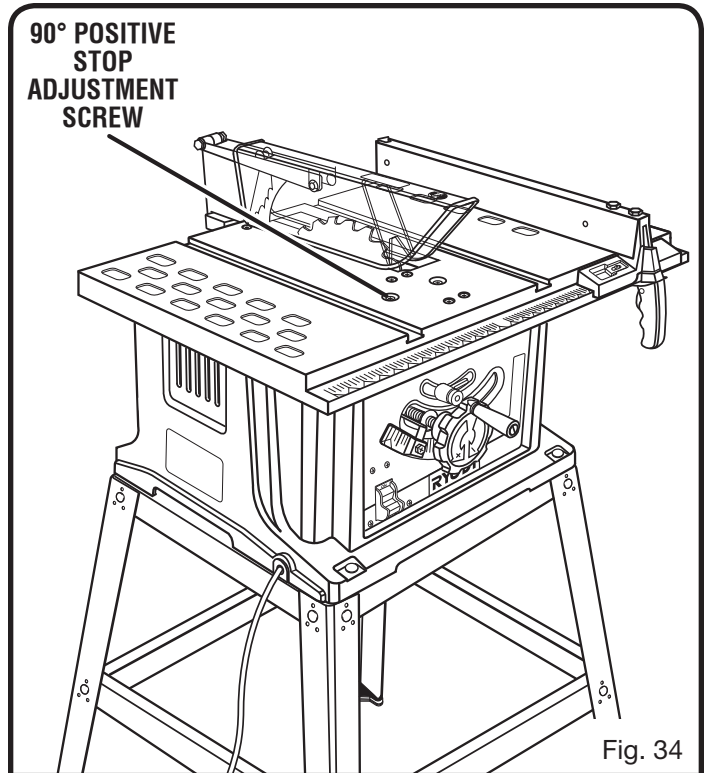

Fig. 34

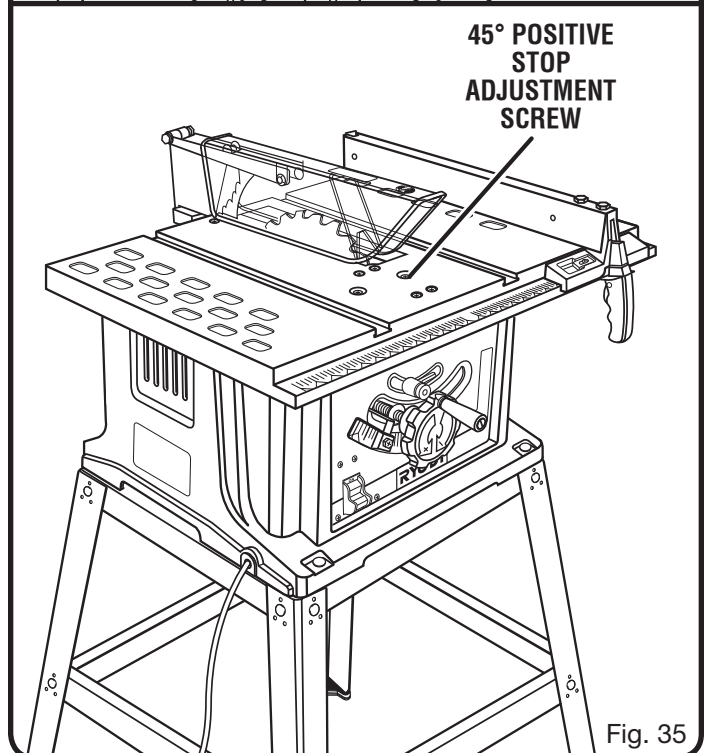

Fig. 35

MAINTENANCE

WARNING:

When servicing, use only identical Ryobi replacement parts. Use of any other parts may create a hazard or cause product damage.

WARNING:

Always wear safety goggles or safety glasses with side shields during power tool operation or when blowing dust. If operation is dusty, also wear a dust mask.

GENERAL MAINTENANCE

Avoid using solvents when cleaning plastic parts. Most plastics are susceptible to damage from various types of commercial solvents and may be damaged by their use. Use clean cloths to remove dirt, dust, oil, grease, etc.

WARNING:

Do not at any time let brake fluids, gasoline, petroleum-based products, penetrating oils, etc., come in contact with plastic parts. Chemicals can damage, weaken, or destroy plastic which may result in serious personal injury.

- Periodically check all clamps, nuts, bolts, and screws for tightness and condition. Make sure the throat plate is in good condition and in position.
- Check the blade guard assembly.
- To maintain the table surfaces, fence, and rails, periodically apply paste wax to them and buff to provide smooth functioning.
- Protect the blade by cleaning out sawdust from underneath the table and in the blade teeth. Use a resin solvent on the blade teeth.
- **Clean plastic parts only with a soft damp cloth. DO NOT** use any aerosol or petroleum solvents.

LUBRICATION

All of the bearings in this tool are lubricated with a sufficient amount of high grade lubricant for the life of the unit under normal operating conditions. Therefore, no further lubrication is required.

TO REMOVE OR CHANGE THE BLADE

See Figure 36.

- Unplug the saw.
- Remove the screws holding the throat plate in place then remove the throat plate.
- Raise the blade to the maximum height.
- To keep blade arbor from rotating, place the open ended wrench on flats located on the left side of the blade.
- Place the second wrench over the arbor nut located on the right side of the blade. Turn nut counterclockwise to loosen.
- Remove arbor nut, outer blade washer, and blade.
- Position new blade on the arbor, making sure the teeth are pointing down toward the front of the table.
- **Attach outer blade washer and arbor nut.**
- Tighten arbor nut, making sure to hold the blade stationary with the open ended wrench.
- Replace throat plate, making sure that the side with the rolled edge underneath is closest to the blade.
- Securely attach throat plate with screws.

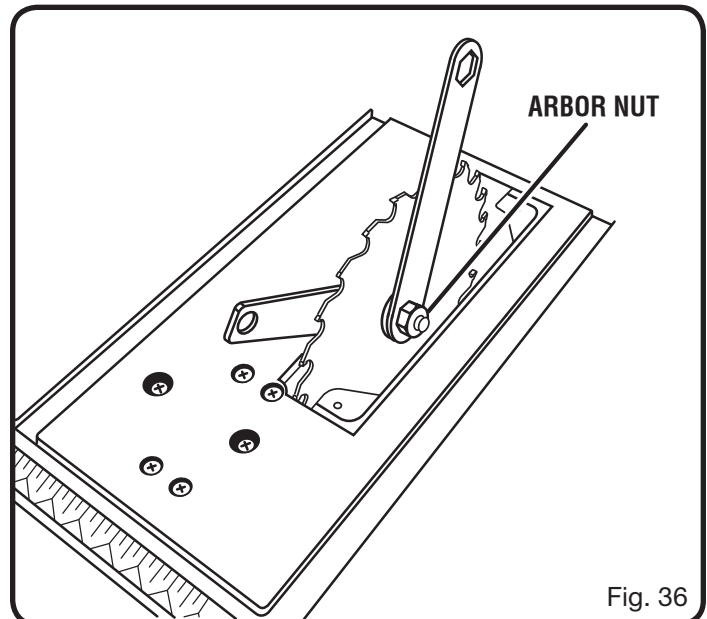

Fig. 36

TROUBLESHOOTING

Problem	Possible Cause	Solution
Excess Vibration.	<ol style="list-style-type: none"> 1. Blade is out of balance. 2. Blade is warped or damaged. 3. Saw is not mounted securely to a level work surface. 	<ol style="list-style-type: none"> 1. Remount and recheck blade. Replace if necessary. 2. Replace blade immediately. 3. Reposition on a level surface and tighten all mounting hardware securely.
Rip fence does not operate smoothly.	<ol style="list-style-type: none"> 1. Rip fence not mounted correctly. 2. Rails are dirty or sticky. 3. Adjustment nut needs adjusting. 	<ol style="list-style-type: none"> 1. Remount the rip fence. 2. Clean underneath front bar of rip fence and front rail. 3. Adjust nut counterclockwise.
Cutting binds or burns work.	<ol style="list-style-type: none"> 1. Blade is dull. 2. Work is fed too fast. 3. Rip fence is misaligned. 4. Wood is warped. 5. Blade is heeling. 	<ol style="list-style-type: none"> 1. Replace or have blade sharpened. 2. Slow the feed rate. 3. Align the rip fence. 4. Replace wood. 5. Call Ryobi Technical Service at 1-800-525-2579.
Wood edges away from rip fence when ripping.	<ol style="list-style-type: none"> 1. Rip fence is misaligned. 2. Blade not properly sharpened. 	<ol style="list-style-type: none"> 1. Check and adjust the rip fence. 2. Have blade resharpened.
Saw does not make accurate 90° or 45° bevel cuts.	<ol style="list-style-type: none"> 1. Positive stops need adjusting. 	<ol style="list-style-type: none"> 1. Adjust positive stops.
Saw does not make accurate 90° or 45° miter cuts.	<ol style="list-style-type: none"> 1. Miter gauge is misaligned. 	<ol style="list-style-type: none"> 1. Recheck setting on miter scale.
Blade makes poor cuts.	<ol style="list-style-type: none"> 1. Blade is dull or dirty. 2. Blade is wrong type for cut. 3. Blade is mounted backwards. 	<ol style="list-style-type: none"> 1. Clean blade or have blade sharpened. 2. Replace with correct type. 3. Remount blade.
Blade does not lower when turning blade control handle.	<ol style="list-style-type: none"> 1. Saw dust build up underneath saw. 	<ol style="list-style-type: none"> 1. Clean underside of saw.
Motor labors in rip cut.	<ol style="list-style-type: none"> 1. Incorrect blade for rip cut. 	<ol style="list-style-type: none"> 1. Change blade to Ryobi 4650301, or similar 24-tooth, carbide rip blade.

