

RYOBI
40 VOLT STRING TRIMMER
MODEL NO. RY40200
ALL VERSIONS
REPAIR SHEET

RYOBI 40 VOLT STRING TRIMMER – MODEL NUMBER RY40200

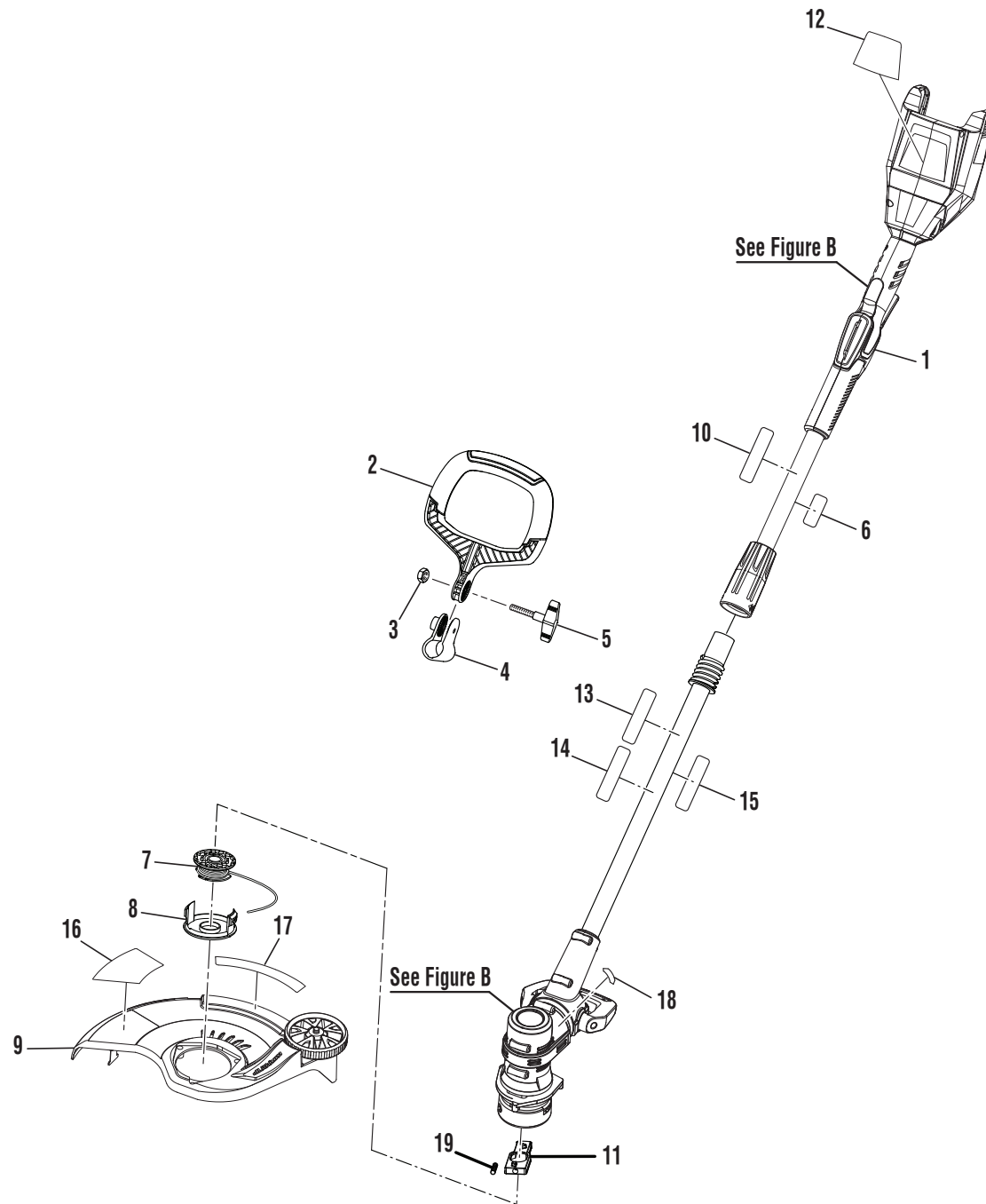

Figure A

RYOBI 40 VOLT STRING TRIMMER – MODEL NUMBER RY40200

The model number will be found on a label attached to the motor housing. Always mention the model number of your **String Trimmer** when requesting service or ordering repair parts.

PARTS LIST (FIGURE A)

KEY NO.	PART NUMBER	DESCRIPTION	QTY
1	31104715G	40V Power Head Assembly	1
2	31302517G	Adjustable Front Handle	1
3	3290205G	Hex Nut (M6).....	1
4	3410605AG	Clamp	1
5	34104517G	Handle Knob.....	1
6	941588022	Data Label (Upper Boom)	1
7	3110382G	Spool w/Line (AC14RSL)	1
8	3411546-7G	Spool Cap.....	1
9	31107517G	Grass Deflector Assembly	1
10	941645001	Warning Icon Label (Power Head)	1
11	310920001	Slider Assembly	1
12	941650001	Logo Label.....	1
13	641646001	Warning Icon Label (Boom)	1
14	941588016	Data Label (Boom)	1
15	941652001	Boom Warning Label	1
16	941649001	Adjustable Cutting Width Label.....	1
17	941648001	Automatic Line Feed Label.....	1
18	099628001001	Rotation Arrow Label	1
19	679034001	Compression Spring.....	1
NOT SHOWN :			
	140181001	Charger	1
	130186006	Battery	1
	988000836	Operator's Manual	
	3-16-12 (REV:01)		

RYOBI 40 VOLT STRING TRIMMER – MODEL NUMBER RY40200

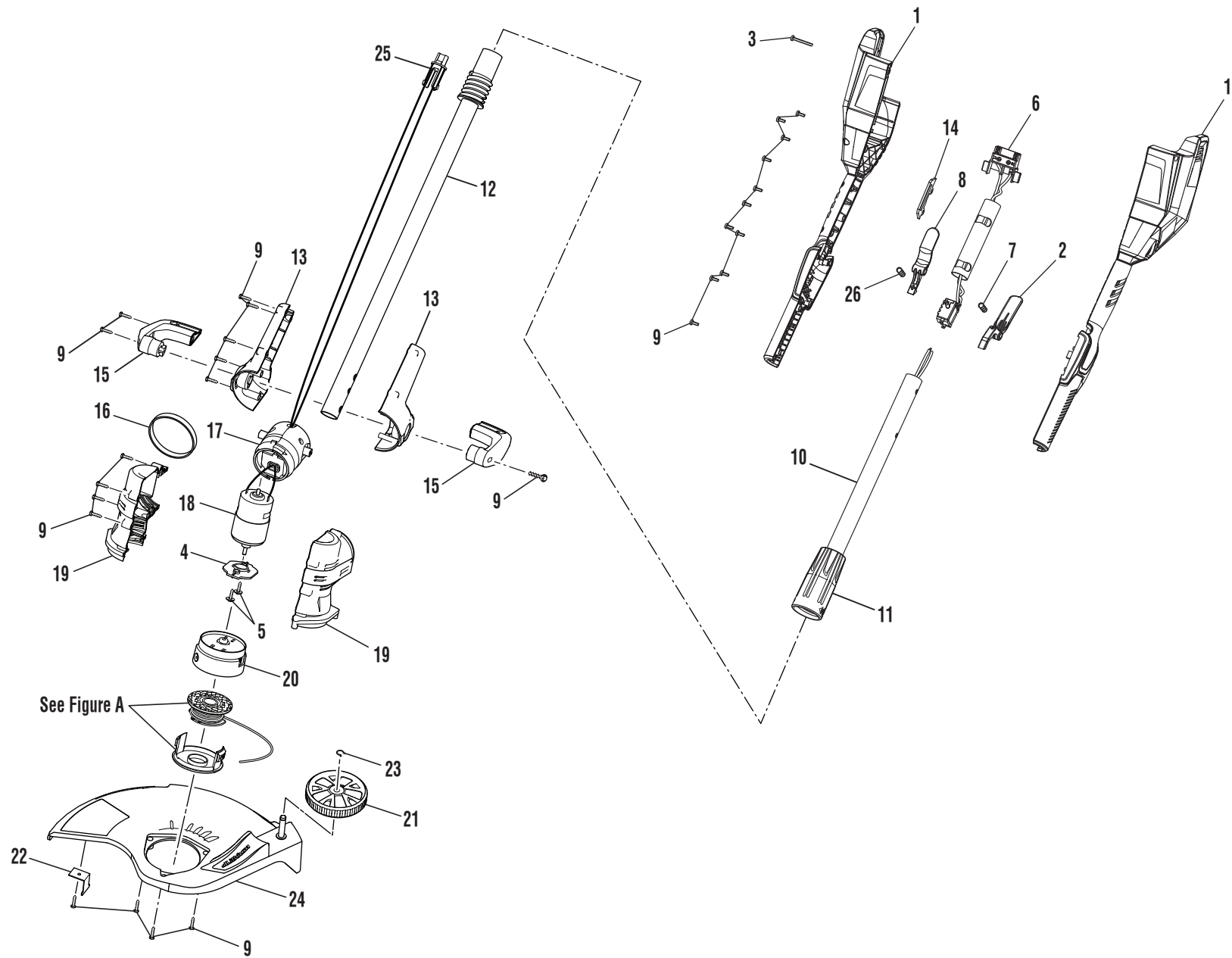

Figure B

RYOBI 40 VOLT STRING TRIMMER – MODEL NUMBER RY40200

The model number will be found on a label attached to the motor housing. Always mention the model number of your **String Trimmer** when requesting service or ordering repair parts.

PARTS LIST (FIGURE B)

KEY NO.	PART NUMBER	DESCRIPTION	QTY
1	099967002003	Handle Assembly	1
2	099967002009	Trigger	1
3	099967002002	Screw (M4 x 30 mm).....	1
4	34106517G	Motor Mounting Plate	1
5	32200517G	Screw w/Washer	2
6	099967002007	Switch and Contact Plate Assembly	1
7	099967002008	Compression Spring	1
8	099967002006	Lock-Out Button	1
9	32201517G	Screw (M4 x 14 mm).....	26
10	31105715G	Upper Boom Assembly.....	1
11	34113508-1G	Coupler	1
12	31106517G	Lower Boom Assembly (Inc. Key No. 25)	1
13	31303517G	Pivot Housing Assembly	1
14	099967002004	Shoulder Strap Hook	1
15	31106715G	Adjustment Pedal Assembly.....	1
16	34105517G	Coupler Ring.....	1
17	31100339G	Pivot Assembly	1
18	31103715G	Motor Assembly (Inc. Key Nos. 4-5 and 20).....	1
19	31305517G	Motor Housing Assembly	1
20	31101345G	Line Head.....	1
21	34109517G	Edger Wheel	1
22	33304517G	Cutting Blade.....	1
23	32901131G	Retaining Ring	1
24	34108517G	Guard	1
25	31109517G	Male Plug.....	1
26	099967002005	Spring	1

RYOBI 40 VOLT STRING TRIMMER - MODEL NUMBER RY40200

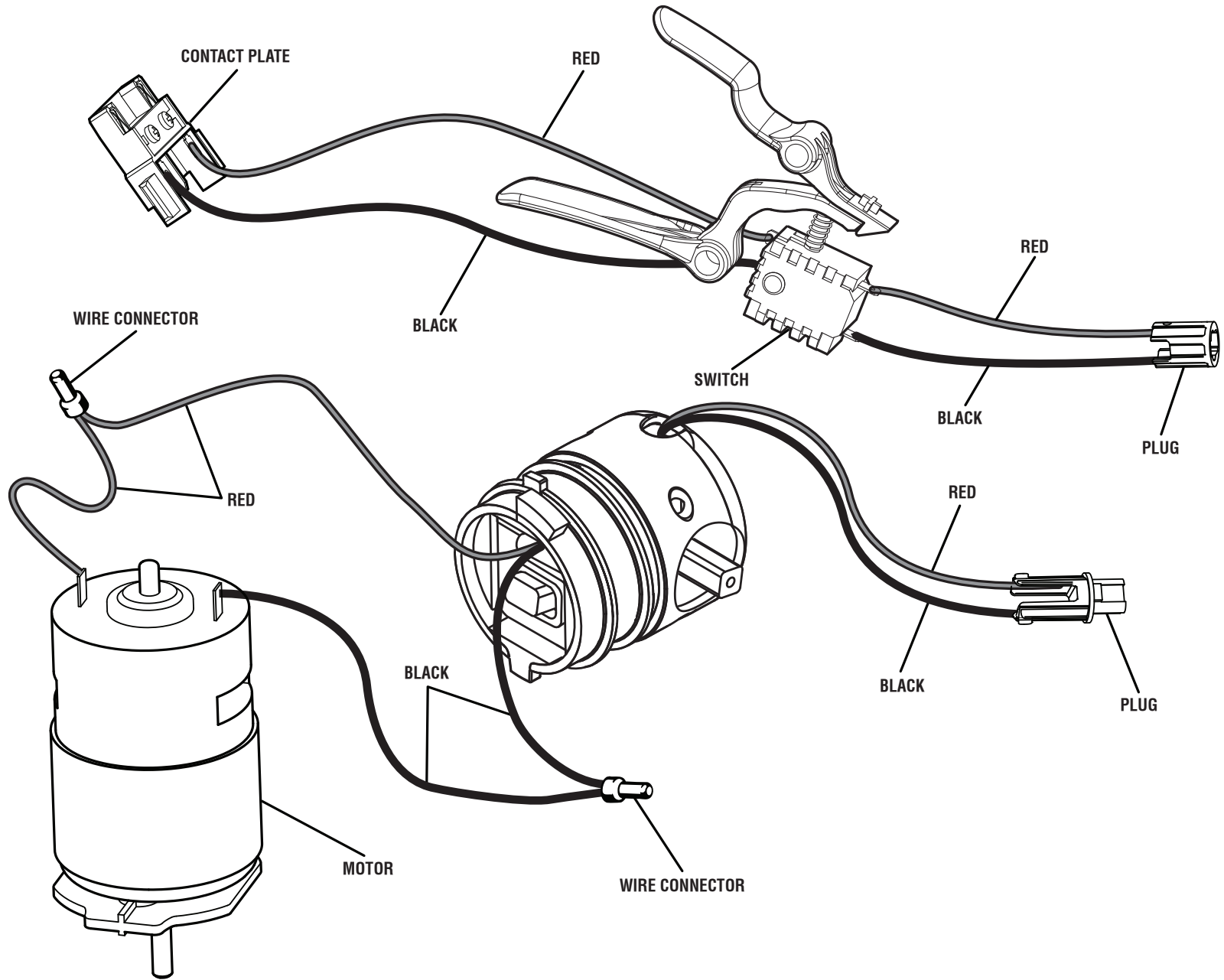

WIRING DIAGRAM