

Thank you and welcome to the world of wireless. This brand new system is designed to provide you with the most audio clarity and strongest anti-interference protection that you can ever imagine.

Follow our instructions in this user guide, and enjoy the easy way of setting up the system and operating the system now.

### **FREQUENCY BAND SELECTION**

Most countries closely regulate the radio frequencies used in the transmission of wireless information.

These regulations state which devices can use which frequencies, and help to limit the amount of RF (radio frequency) interference in all wireless communications.

To be flexible enough to operate worldwide, this new system receiver is available in a number of frequency ranges. Each frequency range, or band, spans up to 30 MHz of the wireless broadcast spectrum. Available bands are:

U0: 614-654MHz

U1: 730-759MHz

U2: 760-789MHz

U3: 790-806MHz

U4: 790-819MHz

U5: 820-849MHz

U6: 850-865MHz

U7: 863-865MHz

U8: 902-928MHz

To facilitate system setup and protect against RF interference, each system comes with multiple predefined frequency **groups** and **channels**.

When using a single system, the operating frequency will generally not have to be changed. In an installation with multiple receiver/transmitter systems, each system must operate on a separate channel. The group and channel system provides an optimum frequency spread when using multiple systems.

Within a single frequency band, up to 13 individual transmitter/receiver systems may be used in a single installation. In regions where additional frequency bands are available, it is possible to operate up to 20 systems simultaneously. Check with your local retailer for information on which bands are available in your area.

---



**TABLE OF CONTENTS**

**System Components ..... 1**

**Receiver Features ..... 2**

**Handheld Transmitter ..... 3**

**Bodypack Transmitter ..... 4**

**Single System Setup ..... 5**

**Multiple System Setup ..... 5**

**Programming**

    Receiver Programming ..... 6

    Transmitter Programming ..... 6

    The Master Frequency List ..... 7-8

**Rack-Mounting Receivers ..... 9**

**Tips for Improving System Performance ..... 10**

**Troubleshooting..... 10**

**Specifications..... 11**



# 1200 Channels PLL Wireless

## System Components

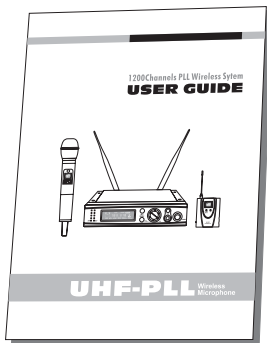
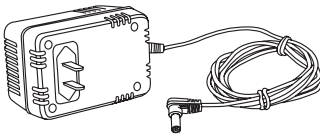
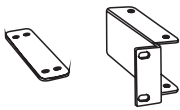
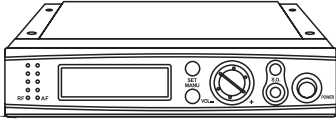

### Any system will include:

- Receiver
- Power supply
- User guide

### Optional accessories:

- Rack mount supplies
  - Short rack ear
  - Long rack ear
  - Link bar to mount to similar receiver
  - 8 rack ear screws
  - 4 rack mount screws with washers
- Extension cables and connectors for front-mounting antennas

### And, a Handheld system will include:

- Microphone head ① (Optional DM-58, EM-11S)
- Handheld transmitter ②
- Microphone holder ③
- 2 AA batteries

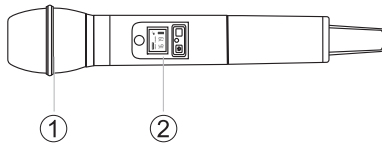

### Or, a Body pack systems will include:

- Body pack transmitter ①
- Lavalier microphone (Optional LV-0211②, LV-6210③, LV-4111④)
- Headworn microphone (Optional HS-4111⑤, HS-6210⑥, HS-0211S⑦)
- 2 AAA batteries

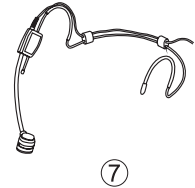
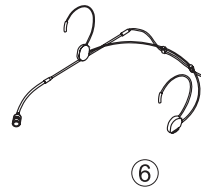
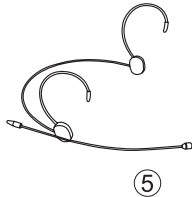
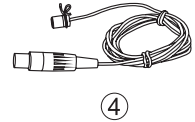
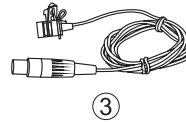
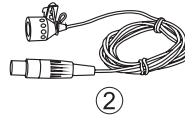
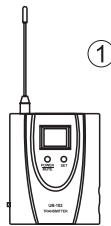

### Or, a Guitar system will include:

- Body pack transmitter ①
- 1/4 jack to mini 4-pin guitar cable ②
- 2 AAA batteries

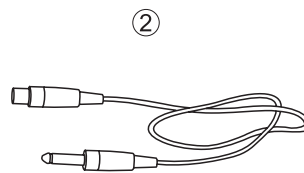
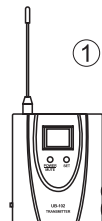

## Handheld Transmitter

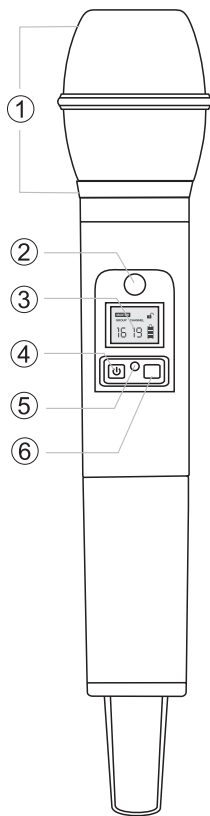

## Features

- ① Interchangeable microphone head
- ② IR port - Receives infrared beam to synchronize frequencies. When using multiple systems, only one transmitter IR port should be exposed at a time.
- ③ LCD screen - See "Transmitter Programming" on page 6.
- ④ On-off / mute switch - Press and hold to turn on or off. Press and release to mute or unmute.

To avoid accidentally muting the microphone during a performance, lock the front panel while the microphone is in use.

- ⑤ Mute indicator- Red: mute on
- ⑥ Set switch - See "Transmitter Programming" on page 6.

## Changing Batteries

Expected life for an Alkaline battery is approximately 8 hours.

When the battery bar in LCD display is empty, the batteries should be changed immediately as shown below:

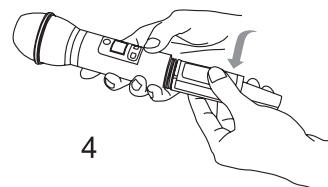
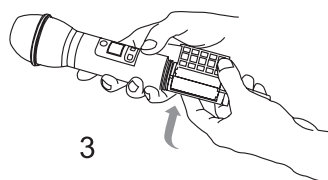
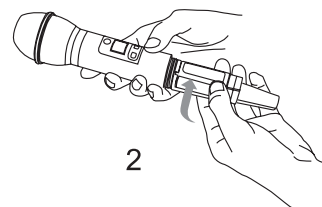
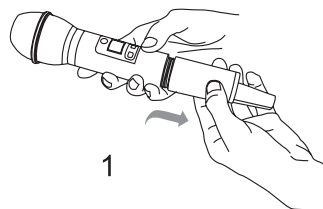

## Bodypack Transmitter

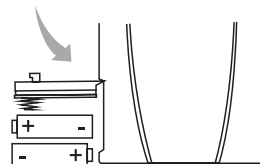
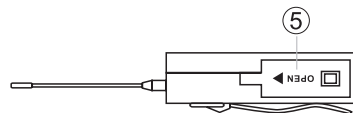
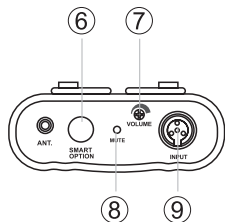
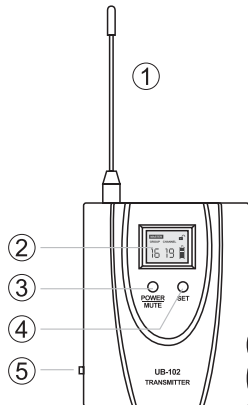

### Features

- ① Antenna
- ② LCD screen
- ③ On-off / mute switch  
Press and hold to turn on or off. Press and release to mute or unmute.
- ④ Set switch
- ⑤ Battery cover
- ⑥ IR port  
Receives infrared beam to synchronize frequencies. When using multiple systems, only one transmitter IR port should be exposed at a time.
- ⑦ Gain adjustment switch
- ⑧ Mute indicator  
Red: mute on
- ⑨ 4-Pin microphone input jack

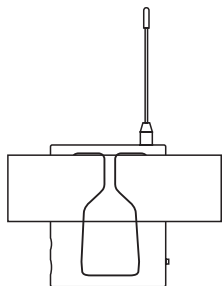

### Wearing the Bodypack Transmitter

- Clip the transmitter to a belt until the belt is pressed against the base of the clip as show on the left.

### Changing Batteries

- Expected life for an Alkaline battery is approximately 8 hours.
- When the battery bar in LCD display is empty, the batteries should be changed immediately as shown below:

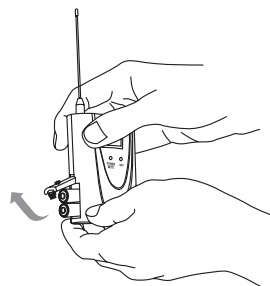
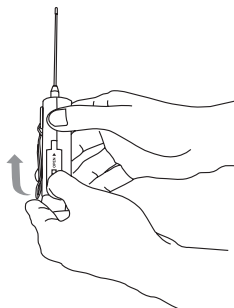

## Single System Setup

Note: transmitting devices such as cellular phones and two-way radios may interfere with wireless audio transmissions. Keep your transmitters and receivers away from these and other potential sources of interference.

Follow these steps when using a single system:

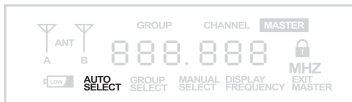

### 1. Automatic Frequency Selection ① menu ② set

Scans for an available channel and sets the receiver to that channel.

### 2. Automatic Transmitter Setup S.O.

Exposed the IR port to the receiver, press S.O.

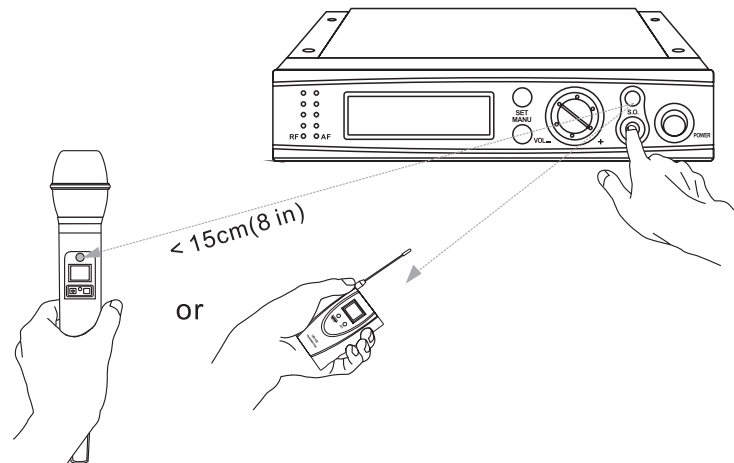

## Multiple System Setup

Follow these steps when using multiple systems in a single installation:

1. Turn all receivers on and all transmitters off.
2. Set all receivers to the same frequency group.
3. Perform Automatic Frequency Selection from the Single System Setup section above.
4. Turn on the first transmitter.
5. Perform Automatic Transmitter Setup from the Single System Setup section above.  
Repeat for each system.

**Be sure that only one transmitter's IR port is exposed when synchronizing a system.**

## Programming

Any option displayed on screen will generally time out after five seconds.

### Receiver Programming

**Group Selection** ① 2x **menu** ② **set** ③ **S.O.**

Allows manual selection of a frequency group. Pressing **set** increases the group number by one. When the correct frequency is displayed press **S.O.**. For best results when operating multiple systems, set all systems to a single group; then set each system to a unique channel within that group.

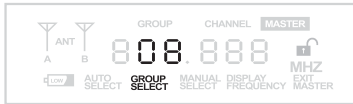

**Manual Channel Selection** ① 3x **menu** ② **set** ③ **S.O.**

Allows manual selection of a frequency channel. Pressing **set** increases the channel number by one. When the correct frequency is displayed press **S.O.**.



**Display Frequency** ① 4x **menu** ② **set**

Display the current frequency in MHz. Press again to display group and channel.

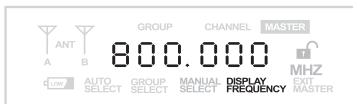

**Lock or Unlock Receiver Settings** **set** + **menu**

Hold down the **set** key and press **menu** to lock or unlock the receiver. When locked, the current receiver settings cannot be changed.

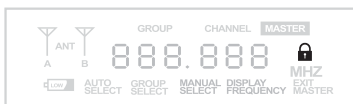

#### Antenna Status

Indicates RF activity. Only one antenna is active at any one time.

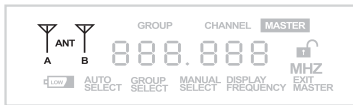

#### Transmitter Battery Status

Indicates a low transmitter battery charge.

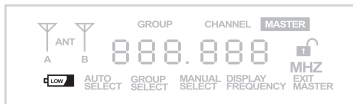

### Transmitter Programming

**Manually Select a Group and/or Channel** **set**

1. Press and hold the **set** button until the GROUP and CHANNEL displays begin to alternate.
2. To change the group setting, release the **set** button while GROUP is displayed. While GROUP is flashing, pressing **set** increases the group setting by one.
3. Press **power** button to switch between GROUP and CHANNEL settings.

Remember to press **power** and **set** button to confirm when the setting is completed.

**Lock or Unlock Transmitter Settings** **power** + **set**

Press the **power** and **set** buttons simultaneously to lock or unlock the transmitter settings. When locked, the current settings cannot be changed manually.

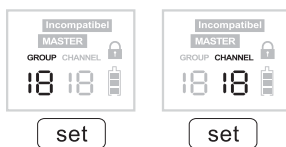

#### Battery Status

Indicates charge remaining in transmitter batteries.



#### Master List Indicator

Indicates that a master list frequency is currently in use. Group or channel information will be display.



Press **set** till GROUP and CHANNEL display begins to alternate. Hold **set** and press **power** till MASTER displays.

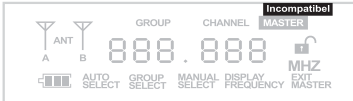

### **INCOMPATIBLE Frequency Warning**

The INCOMPATIBLE warning indicates that the receiver and transmitter are set to incompatible frequency bands. Contact your retailer for assistance.

### **The Master Frequency List**

#### **Receiver**

**Using the Master** **menu** + **power**

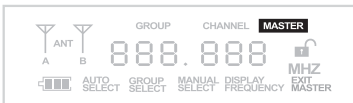

The "Master" of frequencies should be accessed only by experienced users in situations which call for precise frequency selection. The "Master" is a comprehensive index of all available frequencies in 25 kHz increments.

To access the Master, hold down the menu button while powering on the receiver.

#### **Under the display of frequency**

**Select Frequencies in the Master** ① 3x **menu** ② **set** ③ **set** ↑ / **menu** ↓

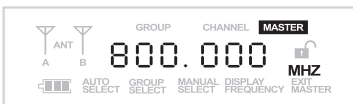

While FREQUENCY is flashing, the set button scrolls up through all available frequencies; The menu button scrolls down. Press and release to change the frequency in 25 kHz increments; press and hold to scroll quickly.

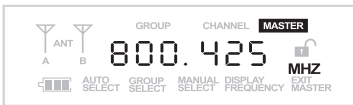

If you know the frequency you need, to speed up your selection, you can follow 2 steps below:

1. Select the frequency under zero, like 0.425MHz.
2. Press S.O., it will switch to select the frequency above zero, like 801MHz. Press and release to change the frequency in 1 MHz increments; press and hold to scroll quickly.

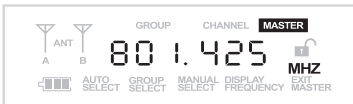

When the correct frequency is displayed, wait five seconds for the screen to time out.

#### **Under the display of group and channel**

**Select Frequencies in the Master** ① 3x **menu** ② **set** ③ **set** ↑ / **menu** ↓

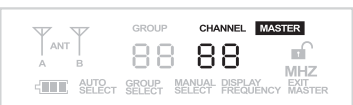

While CHANNEL is flashing, the set button scrolls up through all available frequencies; the menu button scrolls down. Press and release to change the frequency in 25 kHz increments; press and hold to scroll quickly.

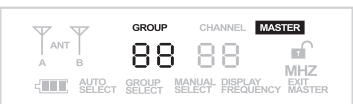

If you know the group and channel you need, to speed up your selection, you can follow 2 step below:

1. Select the channel.
2. Press S.O., It will switch to select the group. Press and release to change the frequency in 1 MHz increments; press and hold to scroll quickly

When the correct group and channel is displayed, wait five seconds for the screen to time out.

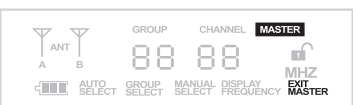

**Exit the Master** ① 2x **menu** ② **set**

To exit the Master and return to normal system operations, press menu, then set.





### **Transmitter**

**Enter the Master Press and hold**  +

While the "Master" is shown, release set + power, then press power + set to enter the "Master."

### **Select Frequencies in the Master**

Press and hold the set button till the group is flashing. Press and release to change the frequency in 1 MHz increments. Press and hold to scroll quickly.

Switch to channel select by pressing the power button.

Press and hold the set button till the channel is flashing. Press and release to change the frequency in 25 KHz increments. Press and hold to scroll quickly.



**Exit the Master Press and hold**  +

While the "Master" is disappear, release set + power, then press power + set to exit the "Master."



## Rack-Mounting Receivers

The supplied mounting hardware allows an receiver to be mounted in any standard 19" audio equipment rack.

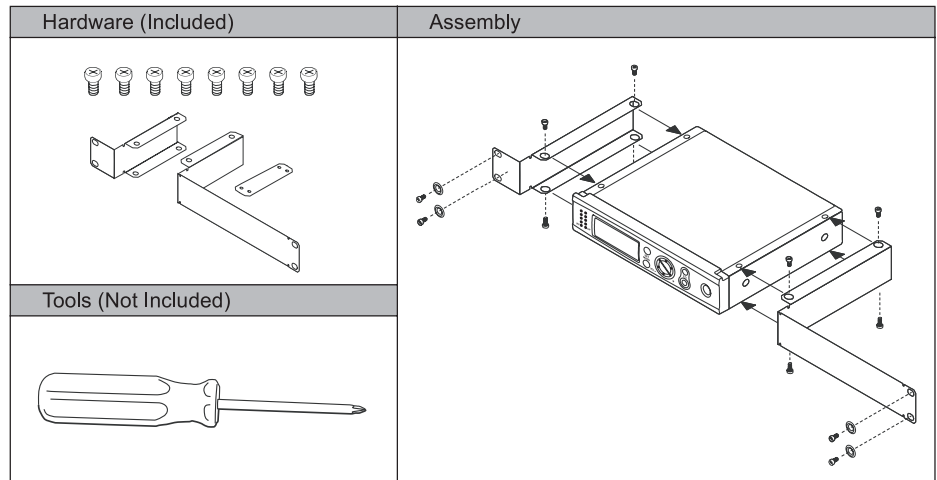

## Tips for Improving System Performance

- Maintain a line of sight between transmitter and antenna.
- Avoid placing the receiver near metal surfaces or any digital equipment (CD players, computers, etc.)
- Secure the AC adapter cable to the receiver using the cable retainer loop
- If rack-mounting the receiver, front-mount the antennas by using the extension cables and connectors.

## Troubleshooting

Issue	Indicator Status	Solution
No sound or faint sound	Transmitter power light off	<ul style="list-style-type: none"> <li>• Turn transmitter on</li> <li>• Make sure the +/- indicators on battery match the transmitter terminals</li> <li>• Insert a fresh battery</li> </ul>
	Receiver LCD off	<ul style="list-style-type: none"> <li>• Make sure AC adapter is securely plugged into electrical outlet and into DC input connector on rear panel of receiver</li> <li>• Make sure AC electrical outlet works and is supplying proper voltage</li> </ul>
	Receiver display indicates antenna activity	<ul style="list-style-type: none"> <li>• Press mute switch on transmitter</li> <li>• Turn up receiver volume control</li> <li>• Increase transmitter gain switch setting</li> <li>• Check cable connection between receiver and amplifier or mixer</li> </ul>
	Receiver display indicates no antenna activity; transmitter and receiver power lights glowing	<ul style="list-style-type: none"> <li>• Extend receiver antennas vertically</li> <li>• Move receiver away from metal objects</li> <li>• Check for line of sight between transmitter and receiver</li> <li>• Move transmitter closer to receiver</li> <li>• Check that receiver and transmitter are using the same frequency</li> </ul>
	Transmitter power light glowing or flashing red	<ul style="list-style-type: none"> <li>• Replace transmitter batteries</li> </ul>
	<b>INCOMPATIBLE</b> warning on transmitter	<ul style="list-style-type: none"> <li>• The <b>INCOMPATIBLE</b> warning indicates that the receiver and transmitter are set to incompatible frequency bands. Contact your retailer for assistance.</li> </ul>
Distortion or unwanted noise bursts	Receiver display indicates antenna activity	<ul style="list-style-type: none"> <li>• Remove nearby sources of RF interference (CD players, computers, digital effects, in-ear monitor systems, etc.)</li> <li>• Change receiver and transmitter to a different frequency</li> <li>• Reduce transmitter gain</li> <li>• Replace transmitter battery</li> <li>• If using multiple systems, increase the frequency spread between systems</li> </ul>
Distortion level increases gradually	Transmitter power light glowing or flashing red	<ul style="list-style-type: none"> <li>• Replace transmitter batteries</li> </ul>
Sound level different from cabled guitar or microphone, or when using different guitars		<ul style="list-style-type: none"> <li>• Adjust transmitter gain and receiver volume as necessary</li> </ul>
FULL warning displays on receiver		<ul style="list-style-type: none"> <li>• The <b>FULL</b> warning indicates that all available channels in the currently selected group are in use. When this occurs, reprogram all systems to an alternate group.</li> </ul>
Cannot turn transmitter off	Transmitter light flashing red	<ul style="list-style-type: none"> <li>• Replace transmitter batteries</li> </ul>

## Specifications

### System

#### Operating Range Under Typical Conditions

100m (300 ft.)

Note: actual range depends on RF signal absorption, reflection, and interference

#### Audio Frequency Response (+/- 2 dB)

Minimum: 50 Hz

Maximum: 20 kHz

(Overall system frequency depends on microphone element.)

#### Total Harmonic Distortion (ref. +/- 30 kHz deviation, 400Hz tone)

0.5%, typical

#### Dynamic Range

>100 dB A-weighted

#### Operating Temperature Range

-18°C (0°F) to +57°C (+135°F)

Note: battery characteristics may limit this range

### UB-102 Bodypack Transmitter

#### Gain Adjustment Range

30dB

#### Input Impedance

500K  $\Omega$

#### RF Transmitter Output

30 mW maximum (dependent on applicable country regulations)

#### Dimensions

85 mm H x 70 mm W x 20 mm D

#### Weight

97 g without batteries

#### Housing

Molded ABS case

#### Power Requirements

2 "AAA" size alkaline or rechargeable batteries

#### Battery Life

>5 hours (alkaline)

### UH-102 Handheld Transmitter

#### RF Transmitter Output

30 mW maximum (dependent on applicable country regulations)

#### Dimensions (including EM-11S cartridge)

270 mm x 52 mm dia.

#### Weight

250 g without batteries

#### Housing

Molded ABS handle and battery cup

#### Power Requirements

2 "AA" size alkaline or rechargeable batteries

#### Battery Life

>8 hours (alkaline)

### UHF-102 Receiver

#### Dimensions

205 mm H x 160 mm W x 39 mm D

#### Weight

960 g

#### Housing

Galvanized steel

#### Audio Output Level (ref. +/- 30 kHz deviation with 400Hz tone)

XLR connector (into 600  $\Omega$  load): -30dBV

1/4 inch connector (into 3000  $\Omega$  load): -9dBV

#### Output Impedance

XLR connector: 200  $\Omega$

1/4 inch connector: 1k $\Omega$

#### XLR output

Impedance balanced

Pin 1: Ground (cable shield)

Pin 2: Audio

Pin 3: No Audio

#### Sensitivity

-105 dBm for 12 dB SINAD, typical

#### Image Rejection

>70 dB, typical

#### Power Requirements

22V dc at 400mA, supplied by external power supply

NOTE:

THE MANUFACTURER IS NOT RESPONSIBLE FOR ANY RADIO OR TV INTERFERENCE CAUSED BY UNAUTHORIZED MODIFICATIONS TO THIS EQUIPMENT. SUCH MODIFICATIONS COULD VOID THE USER AUTHORITY TO OPERATE THE EQUIPMENT.

NOTE: This equipment has been tested and found to comply with the limits for a Class B digital device, pursuant to Part 15 of the FCC Rules. These limits are designed to provide reasonable protection against harmful interference in a residential installation. This equipment generates, uses and can radiate radio frequency energy and, if not installed and used in accordance with the instructions, may cause harmful interference to radio communications. However, there is no guarantee that interference will not occur in a particular installation. If this equipment does cause harmful interference to radio or television reception, which can be determined by turning the equipment off and on, the user is encouraged to try to correct the interference by one or more of the following measures:

- Reorient or relocate the receiving antenna.
- Increase the separation between the equipment and receiver.
- Connect the equipment into an outlet on a circuit different from that to which the receiver is connected.
- Consult the dealer or an experienced radio/TV technician for help.

## FCC STATEMENT

1. This device complies with Part 15 of the FCC Rules. Operation is subject to the following two conditions:

(1) This device may not cause harmful interference.

(2) This device must accept any interference received, including interference that may cause undesired operation.

2. Changes or modifications not expressly approved by the party responsible for compliance could void the user's authority to operate the equipment.

NOTE: This equipment has been tested and found to comply with the limits for a Class B digital device, pursuant to Part 15 of the FCC Rules. These limits are designed to provide reasonable protection against harmful interference in a residential installation.

This equipment generates uses and can radiate radio frequency energy and, if not installed and used in accordance with the instructions, may cause harmful interference to radio communications. However, there is no guarantee that interference will not occur in a particular installation. If this equipment does cause harmful interference to radio or television reception, which can be determined by turning the equipment off and on, the user is encouraged to try to correct the interference by one or more of the following measures:

- Reorient or relocate the receiving antenna.

- Increase the separation between the equipment and receiver.

- Connect the equipment into an outlet on a circuit different from that to which the receiver is connected.

- Consult the dealer or an experienced radio/TV technician for help.

## RF warning statement:

The device has been evaluated to meet general RF exposure requirement. The device can be used in portable exposure condition without restriction.