

SMART SPECTRUM[®]

WIRELESS MICROPHONES

Operating Guide

SWM6000 915 MHz Systems
SWM7000 2.4 GHz Systems

SABINE[®]
WIRELESS SYSTEMS

the sound of innovation[™]

Need other EC docs here

EC - DECLARATION OF CONFORMITY
CE MARKING

We, the Manufacturer

SABINE, INC.
13301 NW US HIGHWAY 441
ALACHUA, FLORIDA USA

declare that the product

RECEIVER
SABINE MODEL SWM7000

Is in conformity with

Council Directive: 73/23/EEC and 89/336/EEC (EMC Directives)
Standards to which conformity is declared:

EN 60065: 2001
EN 55022: 1998 Class B
EN 50082-1: 1998

Manufacturer Signature: _____



Date: 28 April, 2003

Name: Doran Oster, President

Table of Contents

1. INTRODUCTION	5	9. DE-ESSER	33
1.1. Section Contents	5	9.1. De-mystifying De-essers	33
2. PRODUCT VIEWS	6	9.2. The Sabine De-esser	33
2.1. Receivers	6	9.3. Using the De-esser	33
2.1.1. Front panel views	6	10. PROGRAM SAVE & RECALL	34
2.1.2. Back panel Views	6	10.1. Saving a Preset	34
2.2. Transmitters	7	10.2. Loading a Preset	34
2.2.1. Handheld	7	10.3. Naming a Preset	34
2.2.2. Beltpack	7	10.4. Power Off Memory	34
2.3. Components	7	11. MULTIPLE SYSTEMS OPERATION	35
3. QUICK SETUPS	8	11.1. Overview	35
3.1. Receiver & Transmitter Quick Setup	8	11.1.1. Multiple System Interference	35
3.2. FBX Quick Setup	8	11.1.2. Setup Complexity	35
3.3. Tips for Good RF Performance	12	11.2. Antenna Distribution Amplifier	36
3.4. Common Sources of RF Interference	12	11.3. Antenna Distribution Amplifier Connection	36
4. TRANSMITTER OPERATION	14	12. EXTENSION ANTENNAS	38
4.1. First step	14	12.1. Overview	38
4.2. Displays and Settings	14	12.2. Antenna Cabling & Cable Loss	38
4.2.1. LCD Display	14	13. REMOTE CONTROL OPERATION	40
4.2.2. Accessing Transmitter Controls	15	13.1. Overview	40
4.2.3. Adjusting Transmitter Settings	16	13.1.1. Single vs. Multiple Receiver Control	40
4.2.4. Transmitter Battery Management	17	13.1.2. Features & Controls Added Software	40
5. RECEIVER OPERATION	20	13.1.3. Software Multiple Unit Control	42
5.1. LCD Display.	20	13.2. Software Installation	42
5.2. Parameter Control & LCD Display	22	13.2.1. Requirements & Recommendations	42
5.2.1. One set of Controls for 1 or 2 Channels	22	13.2.2. Connections	42
5.2.2. Channel Select / Contrast Button.	22	13.2.3. Installing the Software	43
5.2.3. Special LCD Display Messages.	23	13.3. Launching the software	43
5.3. RF Channel Select	23	13.3.1. Off-Line Edit/Demo	43
5.4. Output Level	23	13.3.2. Connecting Receivers.	43
5.5. Channel Mixing	23	13.4. Remote Control Operation	44
5.5.1. How to toggle channel mixing mode	23	13.4.1. Two Views, Two Sets of Controls	44
5.5.2. Controlling the receiver in channel mixing mode	24	13.4.2. Menu, Icons & Hot Keys	44
5.6. Guitar Cord Simulating	24	14. TIPS & TROUBLESHOOTING	48
5.7. Receiver Antenna Placement	24	14.1. Tips for Maximum Performance	48
5.7.1. Multi-path Interference	24	14.2. Troubleshooting	48
5.7.2. Receiver & Antenna Placement Tips	24	14.3. Common Sources of RF Interference	49
6. MIC SUPERMODELING™	26	14.3.1. RF Sources	49
6.1. Introduction	26	15. FBX THEORY & PRACTICE	51
6.2. Emulation Choices	26	15.1. Introduction to FBX®	51
6.3. Mic Modeling Front Panel Control	26	15.2. The Advantages of FBX Filters	51
6.4. Future Microphone Modeling Choices	27	15.3. Parametric Filters and FBX	52
6.4.1. Mic Model Upgrade Instructions	27	15.3.1. The FBX & True Mobility® Advantage	53
7. FBX FEEDBACK EXTERMINATOR®	28	14.3.2. FBX Fixed & Dynamic Filters	53
7.1. FBX Introduction	28	14.3.3. FBX Filter Width	54
7.1.1. FBX Fixed Filters	28	14.3.4. Who Benefits from FBX?	54
7.1.2. FBX Dynamic Filters	28	15. APPENDICES	55
7.1.3. Balancing Fixed & Dynamic Filters	28	Appendix A: Beltpack Connector Wiring Diagrams	55
7.1.4. FBX Filter Width	28	Appendix B: Antenna System Diagrams	55
7.2. FBX Set Up	28	Appendix C: Specifications	56
7.2. FBX Bypass Button	29	Appendix D: Dip Switch Settings	58
8. COMPRESSOR/LIMITER OPERATION	30	Appendix E: Frequency Chart	59
8.1. Basics of Compression	30	Appendix F: Battery Endurance Tests (Typical)	60
8.2. Using the Compressor	30	Appendix G: Changing Audix Mic Capsules (SW70-H)	60
8.3. Suggested Compression Settings	31	16. CAUTIONS & WARRANTY	61
8.3.1. Vocal Settings	31	INDEX	63
8.3.2. Guitar Settings	31		

This operating guide written for receivers using Sabine SWM Remote Control Software version 2.0 and above.

1. INTRODUCTION

Congratulations on purchasing a Sabine 2.4 GHz Smart Spectrum True Mobility™ Wireless System. True Mobility™ Wireless Systems give you all the built-in processing you need on every microphone, and offer unique and powerful features unavailable with any other wireless microphone.

1.1. Section Contents

- Section 2** **Product Views** — illustrates system components (front & back panel views, transmitters, accessory lists and part numbers).
- Section 3** **Quick Setup** — gives the Quick Setup procedures for Receiver & Transmitter Operation and using the FBX Feedback Exterminator®. Note that there is also a quick-start label on top of your True Mobility receiver for the Sabine FBX Feedback Exterminator®, Compressor/Limiter and De-Esser functions.
- Section 4** **Transmitter Operation** — details transmitter setup and operation.
- Section 5** **Receiver Operation** — details receiver installation and setup.
- Section 6** **Mic SuperModeling™** — explains the use of the Sabine Mic SuperModeling™ and lists the microphones modeled.
- Section 7** **FBX Feedback Exterminator®** — explains how to set up your FBX filters.
- Section 8** **Compressor/Limiter** — explains the use of the Compressor.
- Section 9** **De-Esser** — details operation of the adaptive De-Esser.
- Section 10** **Program Save & Recall** — explains how to save and recall individual program settings.
- Section 11** **Multiple Systems** — how multiple systems interface, computer control of multiple systems, suggestions for maximizing the number of collocated systems.
- Section 12** **Extension Antennas** — how to get maximum performance using a Sabine Extension Antennas (Antenna Distribution Amplifier also available for multi-receiver installations).
- Section 13** **Sabine Remote Control Software** — how to control up to 70 channels from one PC.
- Section 14** **Tips & Troubleshooting** — gives tips on how to get the best performance from your Sabine Wireless, and describes some possible operating problems and their solutions.
- Section 15** **Appendices** — wiring diagrams, frequency charts, specifications, typical system diagrams and dip switch settings for Sabine 2.4 GHz Wireless systems.
- Section 16** **Cautions & Warranties** — states caution and warranty information for your True Mobility™ Wireless system.

Index

Important note about using this Operating Guide

This guide covers the operation of both the SWM6000 and SWM7000 Wireless Systems. The basic operating procedures for these two series are the same. The crucial differences are the frequency bands each of these series uses, and the number of available channels.

SWM6000: Offers XX channels, and uses the 915 MHz band. All transmitters and receivers include the number “6” or the designation “M9” in the part number to denote this series.

SWM7000: Offers 70 channels, and uses the 2.4 GHz band. All transmitters and receivers include the number “7” or the designation “M1” in the part number to denote this series.

These products may be used together in the same location, but remember that transmitters and receivers must always work together. For example, in order for an SWM6000 Series system to work, the transmitters and receivers must both be from that series.

Other components in your system can be mixed between these two series. These include lavalier and headworn mics, mic clips and chargers, cables and adaptors, and anything that is not involved in the transmission or reception of the wireless signal.

2. PRODUCT VIEWS

2.1. Receivers

2.1.1. Front panel views

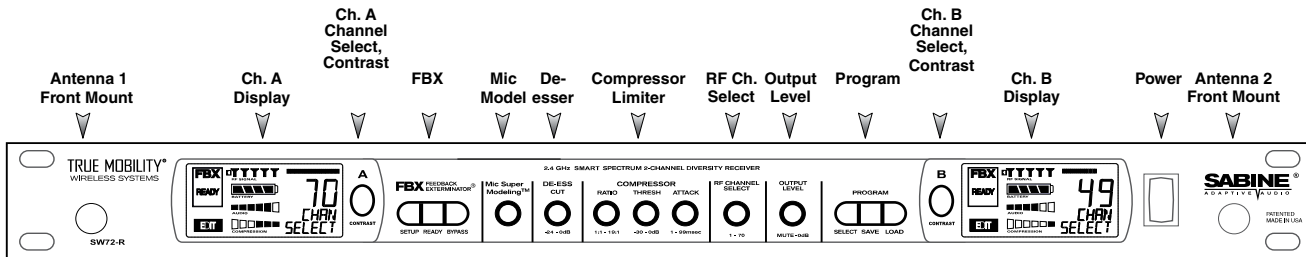


Fig. 2a - SW72-NDR & SW72-R (SW62-NDR & SW62-R) Two-channel Receivers

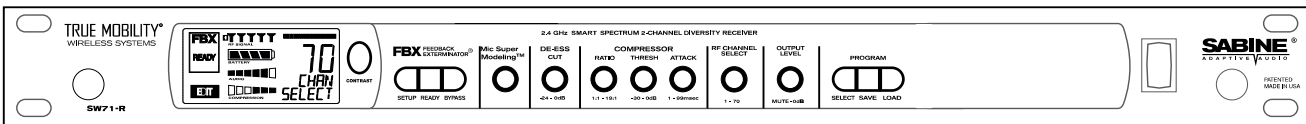


Fig. 2b - SW71-R (SW62-R) One-channel Receiver

2.1.2. Back panel Views

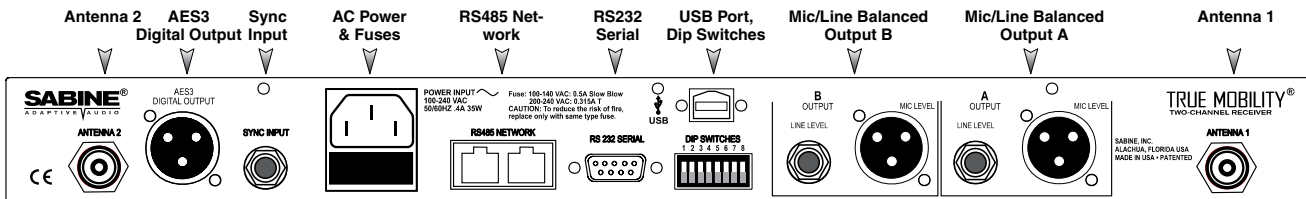


Fig. 2c - SW72-NDR (SW62-NDR) Two-channel Receiver w/Network & Digital Interface

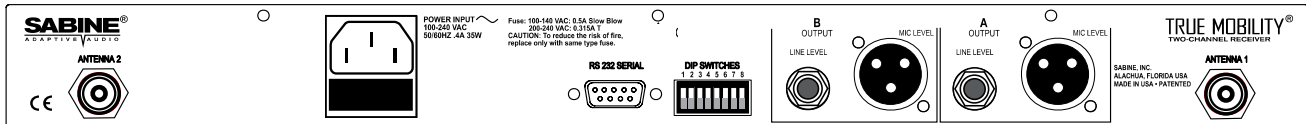


Fig. 2d - SW72-R (SW62-R) Two-channel Receiver

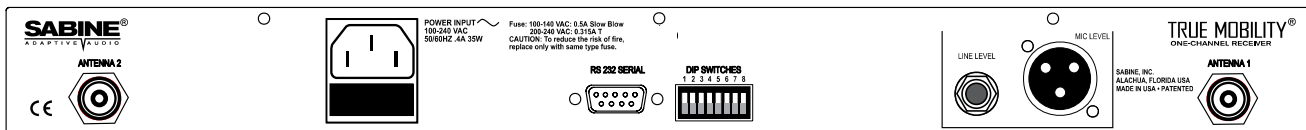


Fig. 2e - SW71-R (SW61-R) One-channel Receiver

See Page 55 for the chart of DIP Switch Settings

2.2. Transmitters

2.2.1. Handheld

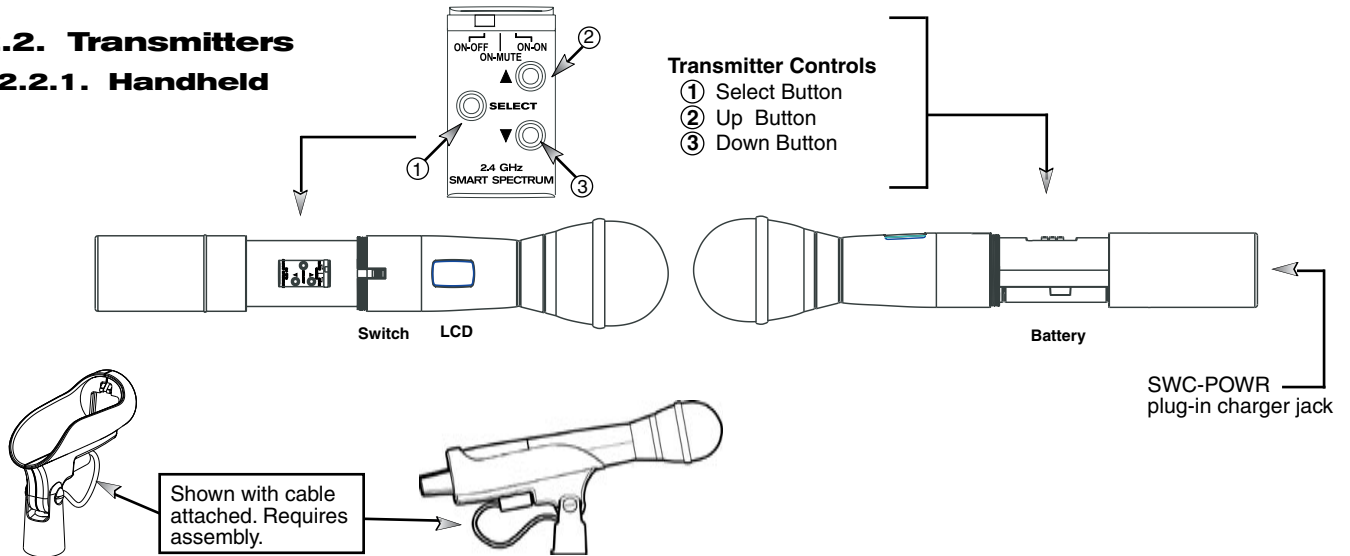


Fig. 2h - SWC70CL - SW70-H13 (SW60-H13), SW70-H15 (SW60-H15) & SW70-H19 (SW60-H19) Mic Clip with Built-in Charger

2.2.2. Beltpack

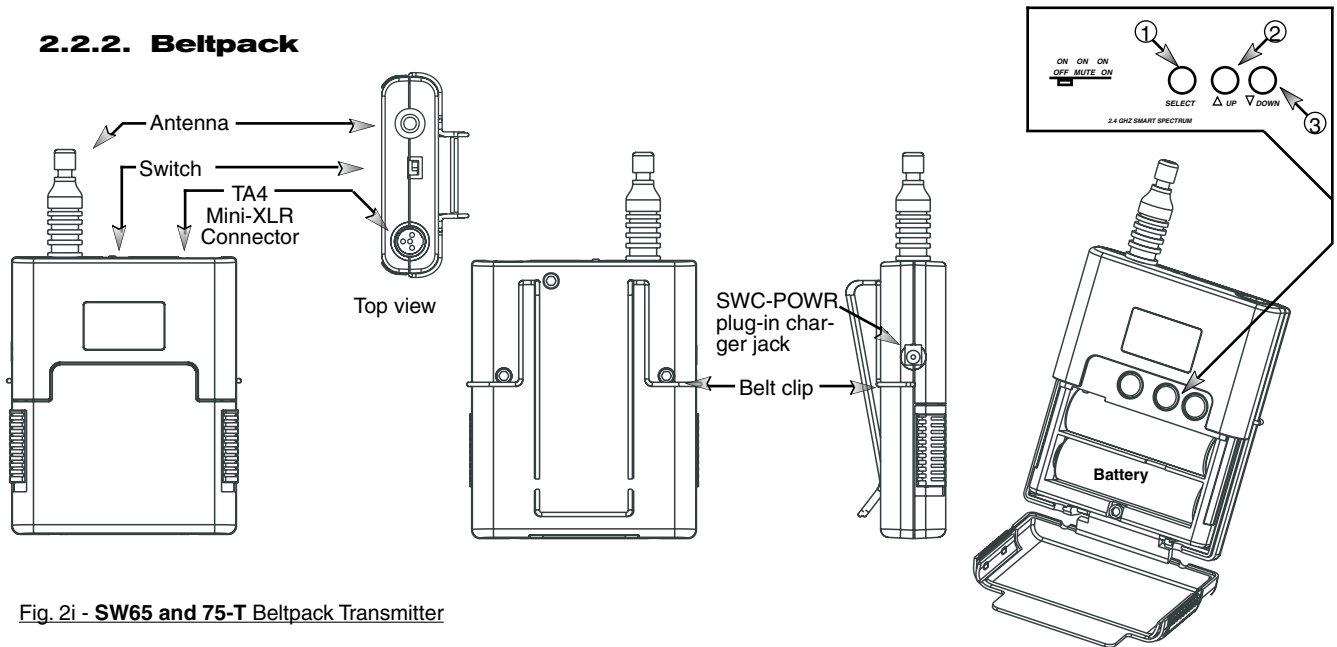


Fig. 2i - SW65 and 75-T Beltpack Transmitter

2.3. Components

(for a complete list see the Sabine Catalog)

Receivers

- SW62 and 72-NDR: 2-Ch. Receiver w/Network & Digital Interface
- SW62 and 72-R: 2-Ch. Receiver
- SW61 and 71-R: 1-Ch. Receiver

Microphones

- SWT31L-TA4: Cardioid Lavalier Mic
- SWT56W-TA4: Headworn Mic
- SVT70BW-TA4: Voice Technologies Omni Headworn Mic (Black)
- SVT70LW-TA4: Voice Technologies Omni Headworn Mic (Tan)
- SVT80BW-TA4: Voice Technologies Cardioid Headworn Mic (Black)
- SWTVT50-TA4: Voice Technologies Miniature Omni Lavalier
- SVT40L-TA4: Voice Technologies Sub-Mini Omni Lavalier
- SWT70G-TA4: Instrument Input w/cable

Transmitters

- SW65 and 75-T: Beltpack Transmitter
- SW60 and 70-H13: Handheld Mic w/Dynamic Element (Audix OM3)
- SW60 and 70-H15: Handheld Mic w/Dynamic Element (Audix OM5)
- SW60 and 70-H19: Handheld Mic w/Condenser Element (VT)

Antennas

- SWA700: TNC Front to Rear Converter Kit (Set of 2)
- SWA6SS: 2.4 GHz Antenna Distribution Amp for 6 systems
- SWASS-EXT: Extension Antenna Kit (Set of 2)
- SWAANT-2.4: 2.4 GHz Antennas (2)
- SWATNC-N: RF Adaptor cable, Set of 4, TNC to NB
- SWATNC-MCA: TNC Male Crimp Connector 2.4 GHz
- SWACA15(or 30)-TNC: RF Cables, RG58, TNC, One Pair

Batteries

- SWBAA2: Rechargeable NiMH AA set for SW75-T & H1

Mic & Transmitter Accessories

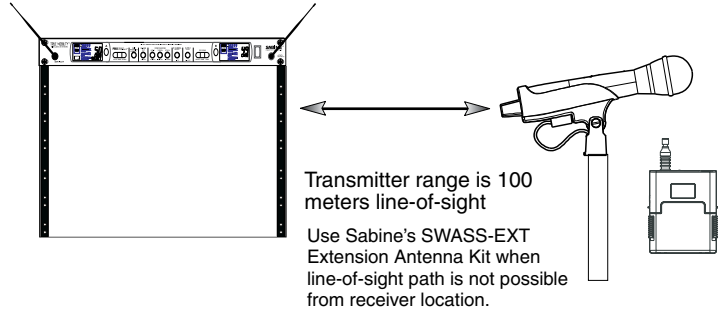
- SWCRJ45: RS485 Serial Cable for ND Receivers
- SWC70CL-1: SW60/70-H Mic Holder w/Built-in Charger
- SWC70CL-12: Stage clip for SW70-H
- SWCPOWR-EXT: Charger extension cable (3 meters)
- SWCPOWR: Plug-in charger for SW60/70 Series Transmitters
- SWC4P-TA4: Standard Mini-XLR Connector

3. QUICK SETUPS

3.1. Receiver & Transmitter Quick Setup

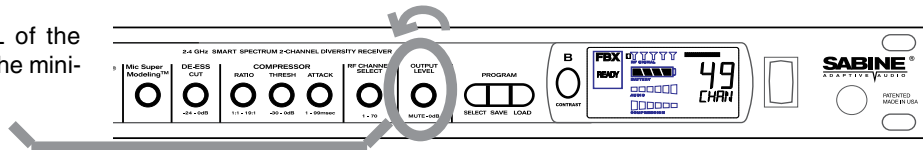
Please read **Section Four Transmitter Operation** and **Section Five Receiver Operation** for a complete understanding of how to set up your Sabine Smart Spectrum True Mobility™ System.

- 1 Selecting RF Channels:** It is best to keep the system's channels close together at the low or high end of the spectrum, i.e. channels 1, 2,3,4,5 or channels 65, 66, 67, 68. If there is another 2.4 GHz source in the room, grouping the channels reduces the chances of an overlap. Do not start by spreading your channels throughout the full channel range of the system – you are more likely to encounter interference this way.

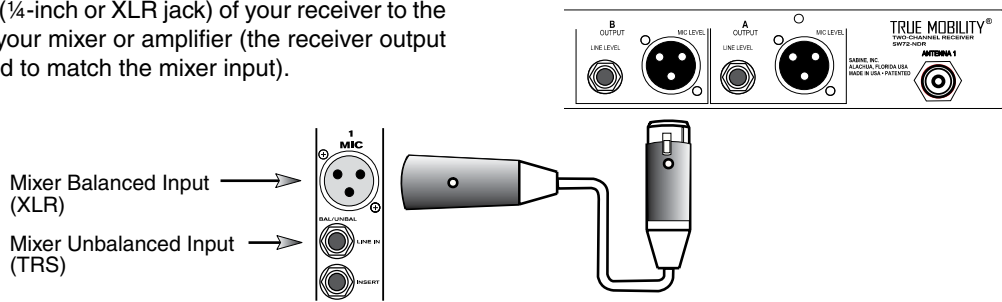


Be sure that all transmitters are off. Position receiver so that the antennas are within visual range of the intended transmitter locations. Transmitter range is about 100 meters, but structural objects in the transmission path can reduce that range. For best results, maintain a line-of-sight path between receiver antennas and transmitters (see Section 12). Use the **TNC Rear-to-Front Kit (SWA700)** included with the receiver to move antennas to front if necessary. See Appendix B for more information on multiple-system connection.

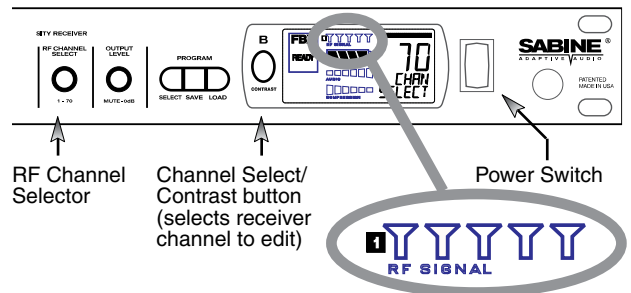
- 2** Turn the **OUTPUT LEVEL** of the receiver and mixer gain to the minimum settings.



- 3** Connect the output (¼-inch or XLR jack) of your receiver to the mic or line input of your mixer or amplifier (the receiver output gain can be adjusted to match the mixer input).



- 4**
 1. Turn on the receiver.
 2. Tap the **Channel Select/Contrast** button to edit a receiver channel. (Not necessary on 1-channel SW71-R & SW61-R receivers).
 3. Turn the **RF Channel Selector knob** to the desired channel.

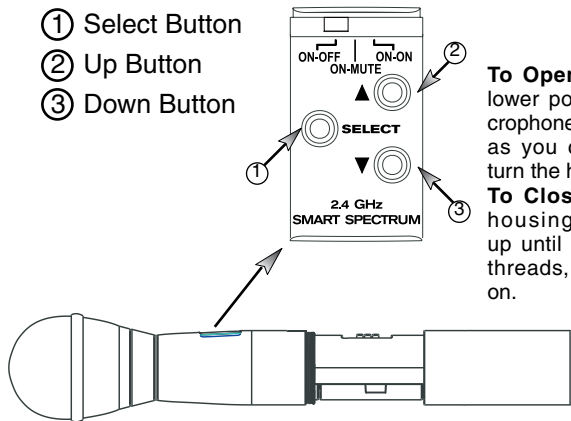


NOTE: Dual channel receivers will not allow you to select the same RF channel for both channels.

NOTE: Front panel RF Signal display will only register Sabine transmitters. It will not show RF interference. Use the RF Scan function in the software to scan for potential RF interference.

Transmitter Controls

- ① Select Button
- ② Up Button
- ③ Down Button

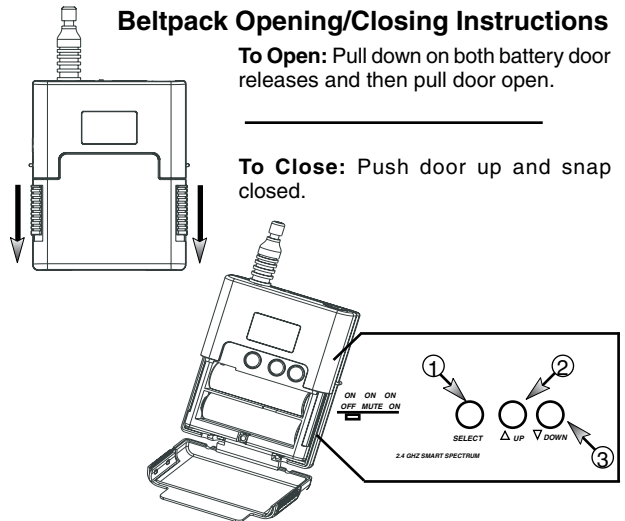


To Open: Unscrew lower portion of microphone. Pull down as you continue to turn the housing.
To Close: Turn the housing and push up until it meets the threads, then screw on.

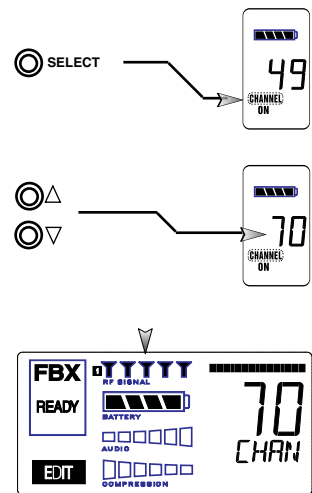
Beltpack Opening/Closing Instructions

To Open: Pull down on both battery door releases and then pull door open.

To Close: Push door up and snap closed.



- 5**
1. Turn on the transmitter.
 2. Use the **SELECT** button until **CHANNEL** appears in the LED. NOTE: the transmitter is **muted during editing**.
 3. Use the **UP** or **DOWN** button until the desired channel appears above **CHANNEL**.
 4. Check that the receiver's **RF SIGNAL** display now indicates a strong signal (at least 3 bars).

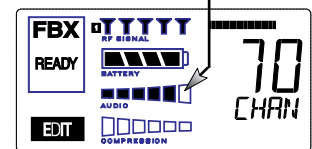


6 Gain Adjustment Settings

1. Transmitter (PAD Adjustment). Adjust the Transmitter PAD setting if last segment of the Transmitter or Receiver Audio Level Meter lights up often, or remains on when mic or beltpack is used.

1. Use the **Transmitter Select** button to scroll through functions until **PAD** flashes in the Transmitter LCD.
2. Use the **Up** or **Down** buttons to select the desired setting. Selection is stored after 3 seconds of inactivity.
3. Check to see if **Audio Level Meter** stays out of **Clipping Zone**

Adjust PAD setting so that Receiver Audio Level Meter stays out of the clipping zone (last segment)



2. Receiver. Adjust the receiver **Output Level** to supply a strong input level to the mixer, amplifier or active loudspeaker. If your receiver output is connected to a microphone level input on the mixer, keep the receiver output gain lower than when connecting to a line level mixer input. NOTE: -10 is a good place to start.

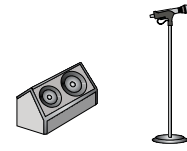
3. Mixer. Adjust the output gain of the mixer so that the mixer output meters approach clipping when all the inputs to the mixer are active, and the audio program reaches its peak level.

4. Amplifier/active loudspeaker/crossover. Finally, adjust the amplifier gain control (and/or crossover gain, if one is used) to provide the desired level of sound pressure in the auditorium or listening area.

See Section 4.2.3 **Adjusting Transmitter Settings** for more information.

3.2. FBX Quick Setup

1 Place microphone and speakers in primary position.



2 Press and hold the **SETUP** button (Fig. 3d) on the receiver until the LCD **SETUP** indicator (Fig. 3e) flashes 4 times and **SETUP** stays lit — then release it.

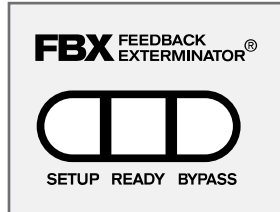


Fig. 3d - FBX: SETUP

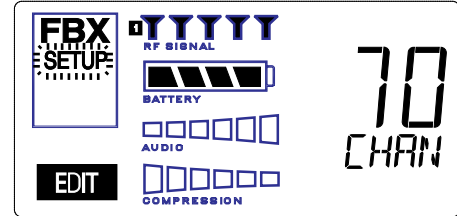
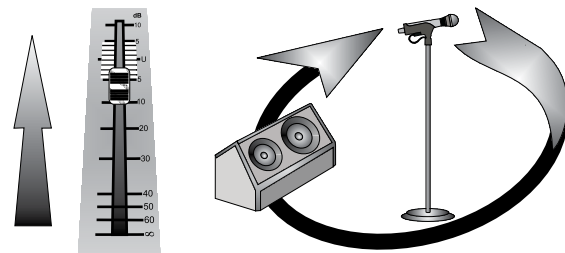


Fig. 3e - SETUP indicator flashing

3 **NOTE: DO NOT TALK INTO YOUR SYSTEM while in Setup Mode.**

Slowly raise the gain on the mixer or amp until FBX eliminates the first few feedback tones. With each new feedback frequency, you will hear a short, quiet burst of feedback that will disappear immediately as a filter is set.

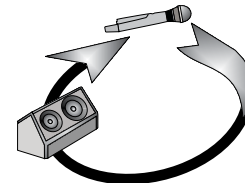


Mixer Channel

Location #1

4 Pause raising the gain, and move the microphone to another area where it will be used. Resume slowly raising the mixer gain, until FBX eliminates a few more feedback tones.

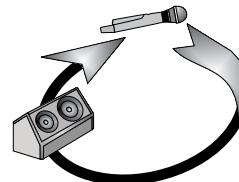
NOTE: When choosing microphone setup locations, try to anticipate likely areas where the microphone will be positioned or moved to, or areas that may be especially prone to feedback problems (e.g., under an overhead speaker).



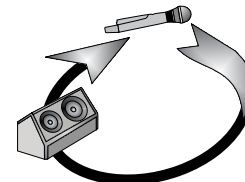
Location #2

5 Repeat until the **SETUP** indicator automatically turns off and the **READY** indicator comes on.

NOTE: You may quit **SETUP** mode at any time prior to its automatic exit by simply pressing the **READY** button. This will enable ready-to-operate status, but with fewer fixed FBX filters in place. In the default factory setting, dynamic FBX filters will still be held in reserve to catch and eliminate new feedback, regardless of how or when **SETUP** mode is exited. (See **Section 14.3.2** for details on the differences between fixed and dynamic FBX filters and **Section 13.4.2.1** for instructions on changing the balance of fixed versus dynamic FBX filters using the Remote Control Software or **Appendix D** for using the Dip Switches on the back of the receiver).



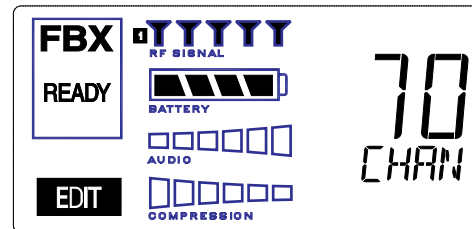
Location #3



Location #4 (if necessary)

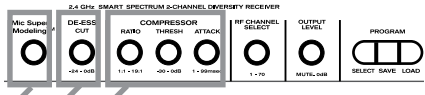
3.2.2. FBX Bypass

The **BYPASS** button (Fig. 3d) bypasses only the FBX filters, and not the additional signal processing (de-essing, compression and Mic SuperModeling™) available on the True Mobility™ Wireless Receiver. This is a useful button that allows comparison of the sound quality when FBX filters are in place, to the sound with no filters (the quality should be very similar). **Before pressing **BYPASS**, take care to reduce your overall system gain so that you do not release suppressed feedback!**



FBX BYPASS CAUTION

Bypassing FBX filters may allow suppressed feedback to be released!



COMPRESSOR/LIMITER

Vocal Settings

RATIO A soft voice could be set to 2:1, whereas a loud voice might require a ratio setting of 6:1.

THRESH The higher the threshold setting, the more signal is required to initiate compression. Ideally this should be set to reign in peak levels, and allow signals of lower gain to pass uncompressed. Threshold settings will depend on the nature and variety of the signal source.

ATTACK Short attack times usually work well for voice. However, too strong a compression ratio, too low a threshold, and too fast an attack may attenuate speech consonants, which provide important intelligibility cues to the audience, thus compromising clarity.

Guitar Settings

RATIO A high compression ratio (with gain makeup) will add sustain to held notes and chords.

THRESH Moving the threshold will change the audible thick/thinness of the guitar tone, but generally you want to compress all the notes played.

ATTACK Be wary of too quick an attack, which may reduce the percussive attack of the guitar notes.

In general, be wary of too much gain makeup, and too high a compression ratio, which may make a noisy guitar amplifier more objectionable. Ratio settings might range from 6 to 19:1, threshold variable, slower attack, soft knee, output gain boosted slightly to significantly depending on amount of compression.

Bass Guitar Settings

RATIO Set to 4:1

THRESH Set to compress peaks only.

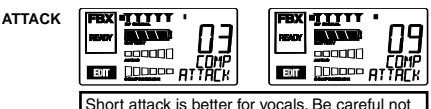
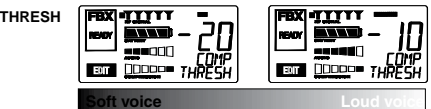
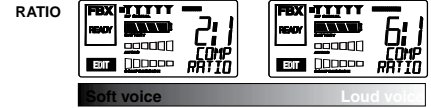
ATTACK Quick attack, medium release, hard knee; (try various release settings, depending on the speed of notes played).

GAIN Output boosted slightly.

DE-ESSER

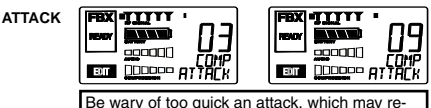
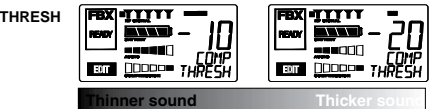
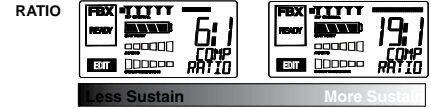
MIC SUPERMODELING™

Vocals

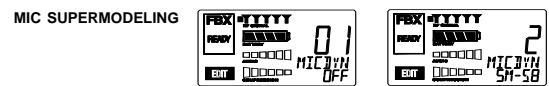
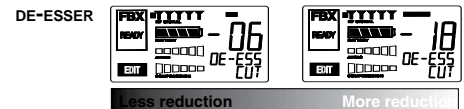


Short attack is better for vocals. Be careful not to over attenuate speech consonants.

Guitar



Be wary of too quick an attack, which may reduce the percussive attack of the guitar notes.



Scroll through available microphone settings. See website for additional downloadable microphones.

NOTE: Mic SuperModeling™ is not available using belt-pack transmitters.

NOTE: Use these settings as a place from which to start, then adjust to your own satisfaction.

3.3. Tips for Good RF Performance

- It is best to **keep the system's channels close together at the low or high end of the spectrum**, i.e. channels 1, 2, 3, 4, 5 or channels 65, 66, 67, 68 (41, 42, 43 on the SWM6000 series). If there are other 2.4 GHz or 900 MHz sources in the room, grouping the channels reduces the chances of overlap. Do not start by spreading your channels throughout the full channel range of the system -- you are more likely to encounter interference this way.
- Avoid potential sources of RF interference by performing a scan using Sabine's Remote Control Software., which will reveal the ambient RF level in your area on each channel of your system. Please refer to Section 13.4.2.5. for information on the RF Scan function, which will automatically determine the best RF channels to use.
- If you cannot perform a scan then proceed to use your system, beginning with Channel 1. If you hear any RF "hits" or dropouts, then move to another of the available channels. If you have multiple mics keep all your channels grouped together.
- For best results, maintain line-of-sight from transmitter to receiver. Use either front or rear panel antenna mounting to maintain line-of-sight.
- Mount receiver antennas at 90 degrees to one another, leaning away at 45 degree angles, in the same plane.
- When using multiple receivers, try to maintain at least 1 foot (30 cm) distance between antennas from different units. When such antenna spacing proves difficult or impossible, we recommend using Sabine's SWA6SS Antenna Distribution Amplifier. The SWA6SS works with up to six receivers, or 12 channels.
- Maximize the distance between the receiver and light sources, such as fluorescent bulbs or neon signs, which may emit very short-range, broadband interference.
- Maximize the distance between transmitters and receivers and potential sources of RF interference.
- Maintain a minimum distance of at least 3 meters (10 feet) between transmitters and receivers or extension antennas. This can solve many anomalies.
- Turn on your system one component at a time, beginning with the first receiver.
- Be careful not to set more than one transmitter to the same channel; each paired transmitter and receiver should be set to unique corresponding channels, until all channels are receiving clearly and cleanly.

Antenna Placement Caution

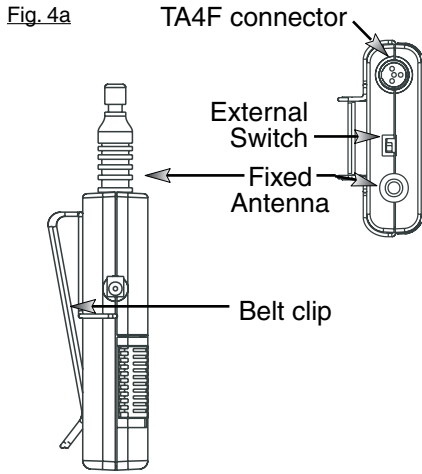
As a general precaution, keep 2.4 GHz or 900 MHz cordless telephones, microwave ovens, WLAN antennas and 2.4 GHz wireless video camera transmitters twice the distance from your Sabine wireless microphone system antennas as that of your Sabine transmitters.

3.4. Common Sources of RF Interference

- **Microwave ovens:** In the vast majority of situations, interference from microwave ovens will not affect performance of your SWM series microphone systems. Since barriers such as walls work to block interference, a microwave oven will likely present a problem only when located in fairly close proximity within the same room as the wireless receiver (or reception antenna). See caution at left.
- **Wireless Local Area Networks (WLANS):** These computer network devices allow computers to connect via wireless devices that act as both receivers and transmitters. These low-powered transceivers often have selectable channels and can utilize the entire 2.4 GHz band. In general, Sabine microphones should not be affected by these WLANS because their spread spectrum technology does not present a problem for the Sabine Smart Spectrum™ system. The Sabine wireless system will not interfere with the WLAN. See caution at left.

- **2.4 GHz or 900 MHz Cordless phones:** These home telephones broadcast at very low power and should not present interference problems for your Sabine wireless. This is especially true if the telephone uses spread spectrum technology. See caution at left.
- **Wireless Video Cameras:** Certain wireless video cameras (X10, for example) use the 2.4 GHz band. These devices are also very low power and, in general, should not present a problem when using the SWM system. See Section 5 Receiver Operation for methods of optimizing clear reception and minimizing interference. See caution at left.

In the event problems still arise, see Section 5 Receiver Operation for methods of optimizing clear reception and minimizing interference.



4. TRANSMITTER OPERATION

4.1. First step

Before you begin, let's look at a few basics regarding your transmitters. The handheld mic is ready to go — the microphone and transmitter are combined in one unit. To use the belt pack transmitter, however, you will have to connect a lavalier or headworn microphone (or instrument pickup) to its input. Sabine lavalier and headworn mics, and Sabine's guitar/instrument connector (SW70G-TA4) come equipped with the proper TA4F connector, and are ready to plug right in. Be sure to line up the pins properly — do not force the connector into the belt pack.

If you are using a different microphone with the Sabine belt pack, please refer to the **Appendix A** for the required wiring plan. Failure to use the proper wiring scheme may damage your mic or the belt pack, and void your warranty.

Use the clip on the back of the belt pack transmitter to attach it to your belt or clothing. The spring clip can be removed and reversed, to allow the transmitter and antenna to point either up or down in its clipped-on position. You can also remove the clip if you choose to keep the transmitter in your pocket. **NOTE:** it is essential that transmitters retain a line-of-sight relationship with the receiver antennas.

4.2. Displays and Settings

Your Sabine Smart Spectrum handheld microphone and belt pack transmitter have many powerful features, all of which are easily monitored (using the transmitter LCD display) and adjusted. The controls and displays for both handheld and belt pack transmitters are almost identical in function, though positioning differs (compare figures 4b & 4c). The LCD display and one control switch are located on the exterior of the transmitters. A more powerful set of recessed controls is located under the hinged access panel, to prevent accidental or inappropriate alteration of settings.

4.2.1. LCD Display

When the transmitter is first turned on, it shows an initial test screen (Fig. 4f), followed by the default screen (Fig. 4g). The LCD also reverts to this default display within a few seconds after any programming changes are made with the recessed controls. The default LCD display always shows transmission channel, audio level, and battery voltage level; additional information will appear to indicate important changes caused either by user adjustments, or automatically as transmitter status changes.

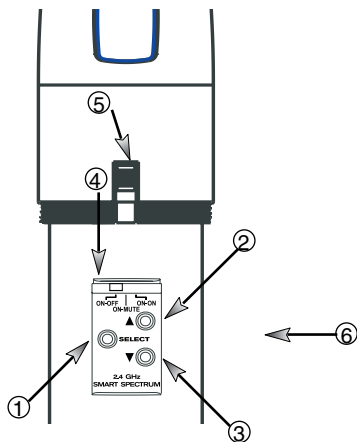


Fig. 4b SW-H series Handheld Control Setting Buttons

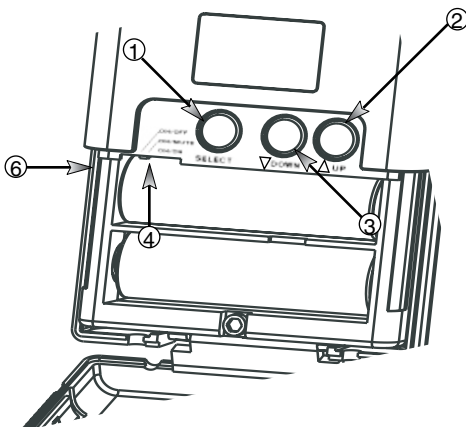


Fig. 4c SW65 & 75-T Transmitter Control Setting Buttons

1. Select Button
2. Up Button
3. Down Button
4. Programmable Control of External Switch
5. External Switch
6. Recessed control and battery compartments

4.2.2. Accessing Transmitter Controls

Control of all your transmitter functions is made using the **Select** button and the **Up/Down** buttons. These control buttons are located inside the access compartment on the beltpack or handheld transmitters.

Opening the Beltpack Transmitter Access Compartment:

1. Using your thumb and forefinger, grab both tabs and simultaneously pull down toward the bottom of the beltpack. This releases the locks.
2. Gently pull the door open.

Closing the Beltpack Transmitter Access Compartment:

3. Swing the door back up and close it by firmly pushing the top part of the door in until you hear the locks click.

Opening the Handheld Transmitter Access Compartment:

1. Unscrew lower portion of the case. Continue turning as you pull down.

Closing the Handheld Transmitter Access Compartment:

2. Begin by turning the lower portion of the case as you push up. When threads meet screw on until snug.

NOTE: Do NOT attempt to unscrew the mic capsule from the body. This will void your warranty!

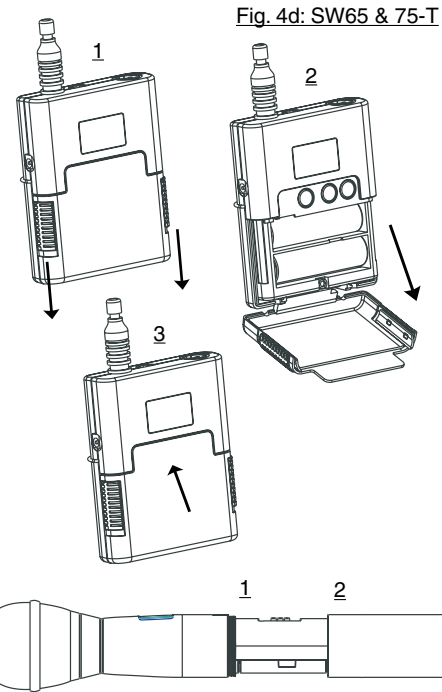


Fig. 4d: SW65 & 75-T

BEFORE CHANGING BATTERY

Turn off transmitter before changing battery(s).

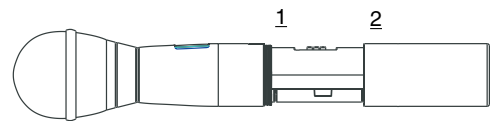
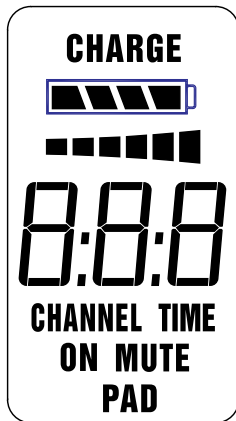
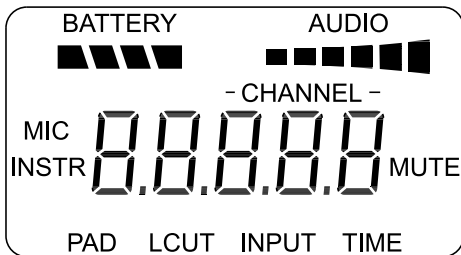


Fig. 4e: SW70-H

Transmitter LCD Display Indicators



SW-H Series



SW65 & 75-T

Fig. 4f: Start up Transmitter LCD displays

CHARGE: Illuminates when the transmitter battery is being charged (i.e., when the charger is connected, either by direct plug-in or by placing the handheld mic in the Sabine charging clip).

BATTERY VOLTAGE LEVEL METER: Indicates measured battery voltage; the more segments illuminated, the higher the voltage, and the greater the remaining battery life.

AUDIO LEVEL METER: Shows the audio output level of the transmitter (affected by the pad setting). The last and largest segment indicates clipping.

PARAMETER VALUE: In default mode this indicates the RF TRANSMISSION CHANNEL chosen for the transmitter. In conjunction with the Select button (see figures 4b & 4c), this field will also display battery run-time hours, or when a low frequency roll-off filter or an attenuation (pad) is active (see Fig. 4g).

"TIME": Displays when battery run-time hours are being displayed.

"MUTE": Indicates output is currently muted.

"PAD": Illuminates when the microphone pad is turned on. Use this if the audio meter shows clipping.

"MIC" INSTR": Indicates SW65 & 75-T beltpack (only) is set to accept either mic or instrument input.

"ON": Illuminates when either the audio and RF transmission, or the RF transmission only, are turned on. (SW-H Series only)

"CHANNEL": Illuminates in default mode to display transmission channel.

Transmitter LCD Display Cycle

Pressing the Parameter Select button cycles the LCD through each of the editable functions on the transmitter. Individual screens appear for approximately 4 seconds, during which the function is editable. The LCD for the SW65 & 75-T is shown. The LCD for the SW-H Series displays the same information in a different layout. See the previous page for a comparative look at both LCDs.

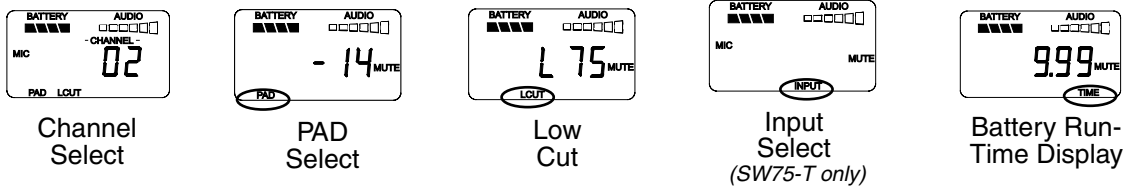


Fig. 4g

Handheld Microphone PAD Settings

Your new Sabine wireless handheld microphone is designed to accept a wide range of input levels, from spoken word all the way up to screaming vocals. In order to accommodate this broad range of inputs, the transmitter has a PAD setting. Handheld mics are set to a factory default of -14 dB, which is the preferred setting for concert vocal performance. If you need more output out of a microphone (the receiver LCD audio meter shows the mic output level) then change the PAD settings as described below. When any level of attenuation is programmed, the default screen will illuminate PAD.

Transmitter PAD Adjustment

(See Fig. 4b, 4f & 4g)

1. Use the Transmitter Select button to scroll through functions until PAD flashes in the Transmitter LCD.
2. Use the Up or Down buttons to select the desired setting. Selection is stored after 3 seconds of inactivity.
3. Check to see if the receiver's Audio Level Meter stays out of the Clipping Zone.

Suggested PAD Settings

Venue	PAD
Speech	0 dB
Loud speech & vocal performance	-6 dB
Strong vocal performance (default)	-14 dB
Very strong vocal performance	-20 dB

Programmable External Switch

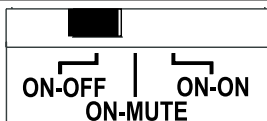


Fig. 4h - Programmable Control of External Switch

4.2.3. Adjusting Transmitter Settings

DEFAULT/CHANNEL: Press the Select button to enter Edit Mode, and repeat until the CHANNEL indicator flashes. In this mode, the Up/Down buttons will adjust Transmission Channel.

INPUT: (SW65 & 75-T Beltpack Transmitter only) Either "MIC" or "INSTR" for microphone or instrument. You are required to choose the input in order to program both the transmitter and the receiver to optimize the input settings. Choosing MIC automatically selects the 75 Hz roll-off filter. You can choose to remove that but the extended low frequency response of the SW65 & 75-T may reproduce too much low energy for your system, so beware. Choosing INSTR automatically removes the 75 Hz roll off filter for that added bottom end in your instruments. NOTE: You can manually change that filter setting as needed.

NOTE

Electric Guitar/Bass & FBX: For best results, when using the SW65 & 75-T Beltpack Transmitter for **electric guitar** or **bass**, put your receiver's FBX Feedback Exterminator into **BYPASS** mode. FBX **BYPASS** is accessible via the receiver front panel or Remote Software control.

NOTE

Guitar Cord Simulator (Beltpack Transmitter Only)

This feature allows you to fine tune the sound of your instrument while it is patched into your Sabine wireless beltpack. For instructions please refer to page 22.

PAD: Transmitter PAD setting. Press the Select button until the PAD indicator flashes. The Up/Down buttons will adjust attenuation (**SW-H Series**) 0, -6, -14, -20 dB; **SW65 & 75-T:** 0, -3, -6, -10, -14, -17, -20, -23, -26, -30, -34, -37, -40 dB). When any level of attenuation is programmed, the default screen will illuminate PAD. See margin notes on this page and p.15 for settings instructions.

TIME: Battery Run-Time Hours. Selecting this option changes the display to indicate the length of power-on time (hours and minutes) since the last battery change or recharge.

NOTE: Battery run-time hours will reset when the transmitter (with battery in place) is connected to a charger. In the case of the charger, run-time hours will not start again until the charger is disconnected. You can manually reset the run-time hours by pressing both the up and down arrows. Use this to count hours when you use alkaline batteries.

LOW FREQUENCY ROLL-OFF: Selecting this option adds a 12 dB/octave low frequency roll-off filter, starting at 75 Hz, to the audio output of the transmitter. A roll-off filter may help reduce microphone handling noise, or other unwanted low frequency content. Pressing the Up or Down button toggles between the conditions of no filter (indicated in the display as L 0) or low roll-off (indicated by L 75).

INTERNAL CONTROL OF EXTERNAL SWITCH: The recessed controls include a 3-position switch, which in turn determines how the transmitter's external two-position switch behaves (see figures 4a, 4b & 4h). From left-to-right, the 3 positions of the internal switch correspond to the following external switch operations:

1. **ON/OFF.** In internal position #1, the external switch acts as a typical on/off switch. Use this setting if you trust the microphone user to switch the microphone on and off as needed, and/or wish to conserve transmitter battery life during down times. In the ON position the transmitter LCD will display ON. Both audio and RF are on. In the OFF position the LCD ON is no longer illuminated. Both RF and audio are off, and the battery run-time hours meter is off. Note that Sabine's squelch system prevents any "popping" when switching the transmitter on and off. However, this protection causes a very short "power-on" delay in the reactivation of the audio when the external switch is turned from OFF to ON.
2. **ON/MUTE.** In internal position #2, the external switch acts as a typical mute switch. Use this setting if you trust the microphone user to switch the microphone audio output on and off as needed; it will not conserve battery life in MUTE condition, but will allow the receiver to monitor and display the RF signal strength in either switch position. In the on position the default LCD will display ON. Both audio and RF are on. In the off position the word MUTE is displayed in the LCD. The audio is muted but the transmitter is still transmitting the RF signal, and the battery run-time meter is running. There are no audible pops when switching the transmitter between MUTE and ON. Switching from MUTE to ON will instantaneously pass audio signal (there will be NO delay as with internal position #1).
3. **ON/ON.** In internal position #3, the external switch is disabled. The transmitter (both RF and audio) is always on, and the word ON is always displayed in the transmitter LCD screen. Use this setting if you do not want to allow the speaker or performer to turn off the transmitter, or are worried that a transmitter may be accidentally turned off. Caution: When your program is over we suggest you move this switch to another setting so you can turn off the transmitter and save your battery. You may also elect to remove the battery (though replacing the same one will restart the run-time meter and affect its accuracy accordingly).

Once you have completed the transmitter setup, you are ready to work with your receiver (see Section 5). First, however, let's talk about the issues and solutions concerning the source of transmitter power: the battery.

4.2.4. Transmitter Battery Management

4.2.4.1. Battery problems and Sabine solutions

Rechargeable Battery memory. Batteries that are repeatedly recharged prior to a complete discharge may fail more quickly in subsequent uses. This problem is usually referred to as "battery memory." Fortunately, Sabine's innovative Tireless Wireless™ Charger takes steps to avoid this problem, by automatically reconditioning the battery whenever its intelligent diagnostics determine this is appropriate. Sabine's Tireless Wireless™ Charger will insure maximum life per battery charge, and also prolong the useful multiple-charge life span of rechargeable batteries.

Battery life. Both handheld and beltpack transmitters can work with disposable alkaline, disposable heavy-duty (manganese dioxide-carbon zinc), or rechargeable Nickel Metal Hydride (NiMH) batteries. We specifically caution against using NiCad rechargeables due to well-known battery memory problems, and specifically recommend using the Sabine-supplied SWBAA2 (AA for the H1 Series handhelds and beltpack) batteries. The rechargeable SWBAA2 batteries will last about 8 hours per recharge (typically, alkaline AA batteries will last about 10 hours). NOTE: Heavy-duty batteries will fall somewhere in the middle, between rechargeables and alkalines.

Beltpack Transmitter PAD Settings

The SW65 & 75-T beltpack transmitter has a broad range of PAD settings, which allow you to use it with almost any microphone or instrument. As in all audio equipment, the setting of the input level is crucial to achieving the best sound quality. Setting minimal PAD levels (-3, -6, or -10 dB) may produce a distorted sound if you are using a high output microphone or instrument. Conversely, setting a more extreme PAD level (-40, -37, or -34 dB) may require you to raise your system gain unnecessarily, resulting in a noisier output. Watch the input meter on either the transmitter or the receiver (see illustrations) and set your level so there are at least three indicators illuminated for normal program level, with an occasional move to the fourth indicator. The fifth and biggest indicator denotes clipping – watch out! If you see clipping, choose a lower pad setting (for example, from -10 to -14 dB).

Transmitter PAD Adjustment

(See Fig. 4c, 4f & 4g)

1. Use the Transmitter Select button to scroll through functions until PAD flashes in the Transmitter LCD.
2. Use the Up or Down buttons to select the desired setting. Selection is stored after 3 seconds of inactivity.
3. Check to see if the receiver's Audio Level Meter stays out of the Clipping Zone.

Suggested PAD Settings

Venue	PAD
Low output microphones	-10 dB
Standard mics; acoustic instruments with low-gain pickups	-17 dB
Electric guitars with low-gain pickups & mics with higher gain	-23 dB
Most standard electric guitars	-26 to -34 dB
Instruments with high-gain pre-amps	-37 dB

See the Transmitter Quick Guide that came with your transmitter for a complete look at the suggested pad settings. Default pad setting is -30 for SW65 & 75-T.

IMPORTANT BATTERY INFORMATION

Acceptable Batteries for use with
Handheld & Beltpack Transmitters

SW70-H1, SW65- & 75-T Transmitters

2 "AA" size (14.5x50.5mm 卓3電池2本使用)

- NiMH Rechargeable (Sabine part #: SWBAA2)
- Alkaline: NEDA 14A - ANSI 14A - IEC LR14
- Heavy Duty batteries (NOT recommended)

Alkaline batteries must be one of following types:

NEDA: 14A ANSI: 14A IEC: LR14

WARNING! DO NOT USE Alkaline Rechargeable Batteries



FIRST-TIME BATTERY CHARGING

Your Sabine True Mobility® transmitter comes with one or more rechargeable NiMH batteries. **For best results, charge the battery for at least 8 hours before using it for the first time.** Please note that the full charging potential of the battery will be achieved after the first 5 charging cycles have been completed.

NiMH rechargeable batteries are highly resistant to "memory effect," which affects some other rechargeable batteries. The included NiMH batteries will provide more lifetime charges and longer battery life for each charge than many other rechargeable batteries.

BEFORE CHANGING BATTERY

**Turn off transmitter before
changing battery(s).**

Sabine rechargeable battery advantages. Here are several more good reasons why you can feel more confident about using rechargeable batteries:

1. All transmitters report two types of battery status information. The first report is the all-important voltage the battery is supplying. Second, you'll know how long the battery has been in use (battery run time hours). Each receiver channel also receives telemetry information from its associated transmitter, regarding the battery voltage, and displays the information in the receiver LCD (see figure 5b). When the voltage reaches a level indicating an estimated 30 remaining minutes of useful battery life, both transmitter and receiver automatically flash warnings in their LCD displays. As an alternative means of anticipating battery depletion, you can check the number of hours of use, by checking the transmitter LCD display (see Section 4.2.2 and figure 4g), or the Remote Control Software.
2. The handheld microphone clip that we provide with each handheld transmitter not only holds the microphone — it also can double as an unobtrusive charger housing. Anytime the mic is parked in the clip (and the clip is connected to the charger power supply), the mic is being charged. As an additional safety margin against battery failure, the mic placed in the powered clip gets its power from the charger, not the battery, so it will work perfectly even if the battery is completely dead.
3. Sabine's intelligent charger circuitry detects the type of battery in place within the battery compartment, and automatically turns off the charger if the battery is not compatible with the charger.
4. The Tireless Wireless™ Charger detects when a battery is fully charged, and turns off the charging cycle.
5. The Tireless Wireless™ Charger prevents futile attempts to resuscitate dead batteries — if the battery is unresponsive, the charging cycle is stopped.
6. Beltpack and handheld batteries can be recharged without removing them from the transmitters. Just connect charger plug to the transmitter jack (see Fig. 4l).

NOTE: In the "most discharged" battery condition, a full recharge may take up 8 to 12 hours depending on the mA value of the AA batteries used with the handheld and beltpack transmitter. The charging system will charge a batteries with a mA value of up to 2400. When in doubt, charge the batteries overnight. Sabine's battery-protection circuit will shut the charger down when charging is completed.

4.2.4.2. Charging Your Batteries

Equipment Connections. Each SW65- & 75-T or SW-H Series transmitter comes equipped with an SWC-POWR Tireless Wireless™ plug-in charger (see Fig. 4l). In addition, each SW-H comes with its own battery-charging mic clip (SWC70-CL). The SWC-POWR charger can be plugged directly into either the transmitter or into the clip. A Sabine rechargeable battery (SWBC1) will charge whenever the mic clip is connected to the Sabine SWC-POWR charger and the handheld is properly placed within the mic clip.

Charging Indicators. Much like your cell phone, the transmitters will let you know the charging status of the battery. When the battery is charging, the battery meter will flash to indicate the relative level of the charge — one, two, three or four elements will flash (see Fig. 4i).

Once the battery is fully charged, all four elements in the battery meter will flash. This indicates that the charging circuit is no longer on (see Fig. 4j).

NOTE: The right-side indicator segment will flash for several minutes when charging is first attempted (see Fig. 4h). The lower the battery level, the longer this initial “testing/not charging” flashing sequence will continue. During this time, the Tireless Wireless battery circuit is evaluating the suitability and charge status of the battery in place. When it has completed its evaluation, it will either commence the progressive flashing depicted in figure 4i (CHARGING), or continue to flash (TESTING/NOT CHARGING). All segments flashing in unison signifies that the battery is fully charged (see Fig. 4j).

These same indications will also be displayed on the receiver LCD, and on the Remote Control Software screen.

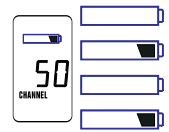
NOTE: The Tireless Wireless battery charger will only charge NiMH rechargeable batteries. If you place any other kind of battery in the transmitter, and then attempt to charge it by connecting the charger, the Tireless Wireless circuit will detect the type of battery and will not begin charging. Again, the battery indicator on the transmitter will flash the right-side element indicating testing/no charging (see Fig. 4h).

Battery Warnings. When the transmitter battery voltage drops below a critical threshold, the battery icon (which normally displays the voltage level) will begin to flash. This will occur on the transmitter and receiver and is an indication that you need to replace the battery, or charge it by placing the handheld mic in the charger clip. **NOTE:** Microphone will still transmit audio when placed in clip. Alternatively, you can connect the charger directly to the transmitter using the built-in charger jack located on the side of the beltpack transmitter and near the antenna on the handheld transmitter (see Fig. 4l). If the battery is not changed or recharged, the transmitter will eventually turn off (see Fig. 4k).

NOTE: When the battery has reached a specific discharge level, the transmitter will automatically turn off, and the transmitter LCD will display the message at right.

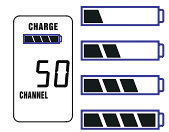


Fig. 4h: TESTING/NOT CHARGING



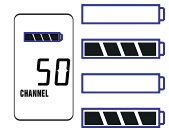
Right-side battery indicator segment will flash to indicate that the battery is being tested. This occurs prior to charging a NiMH battery and whenever a non-rechargeable battery is placed on charge. Charging is not occurring when indicator lights in this fashion.

Fig. 4i: CHARGING



Battery indicator segments will flash progressively starting from the relative charge state of the battery. This example depicts a fully discharged battery being charged. As the charge progresses, left-side segments will remain visible as right side segments continue to flash, until all segments are visible. At that point, all segments will flash on and off in unison (see Fig. 4j).

Fig. 4j: FULL CHARGE



Battery indicator segments will flash in unison to indicate that the battery is fully charged.

NOTE: Battery can be left connected to the charger and will receive periodic maintenance charging.

Fig. 4k: Battery CHARGE LEVEL displays

- Fully Charged
- Partially Used
- Very Used
- Very Low (Flashing)

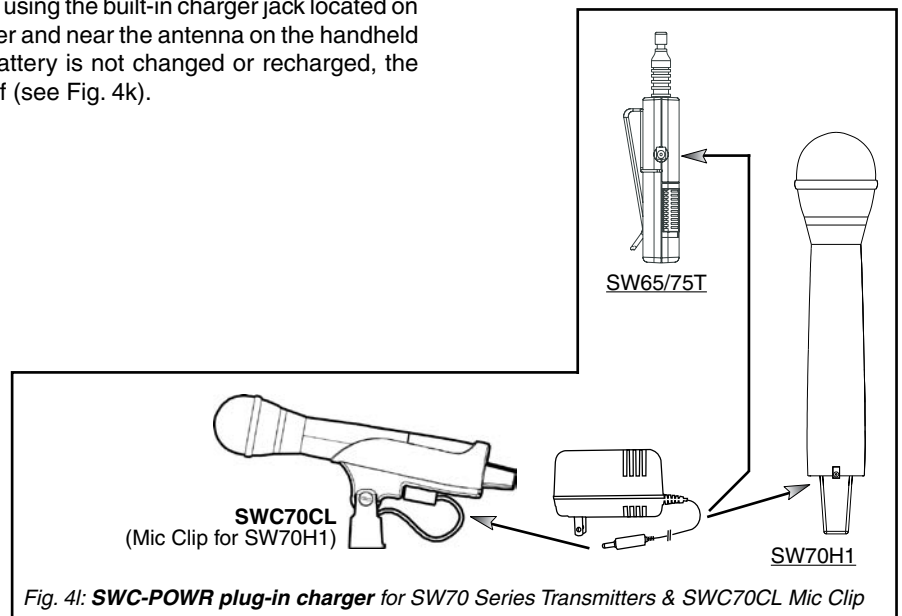


Fig. 4l: SWC-POWR plug-in charger for SW70 Series Transmitters & SWC70CL Mic Clip

5. RECEIVER OPERATION

5.1. LCD Display.

The receiver LCD display is shown below (Fig. 5b). Two-channel receivers feature two LCDs, one for each channel. The display provides a snapshot report of the condition of your wireless channel, including battery status information sent from the transmitter by telemetry.

The right two-thirds of the display primarily shows status information regarding the condition of your receiver channel, as follows:

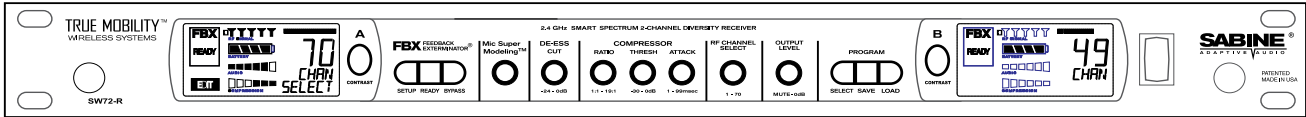


Fig. 5a: SW72-R (SW62-R) front panel

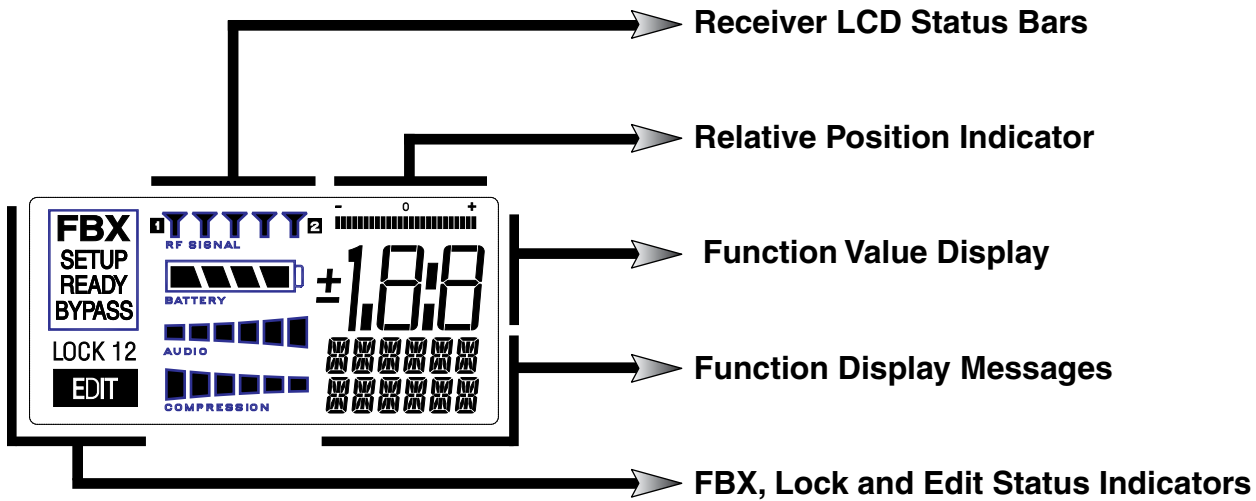
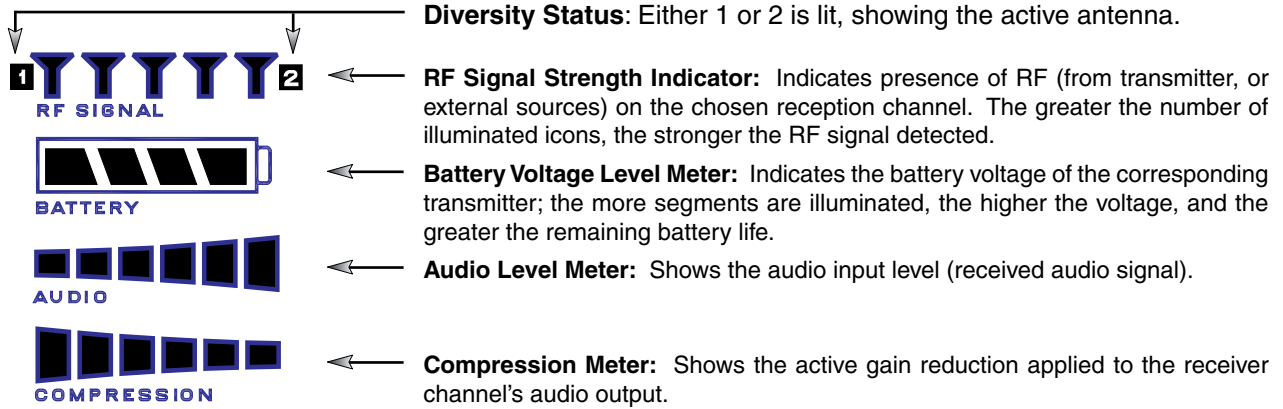
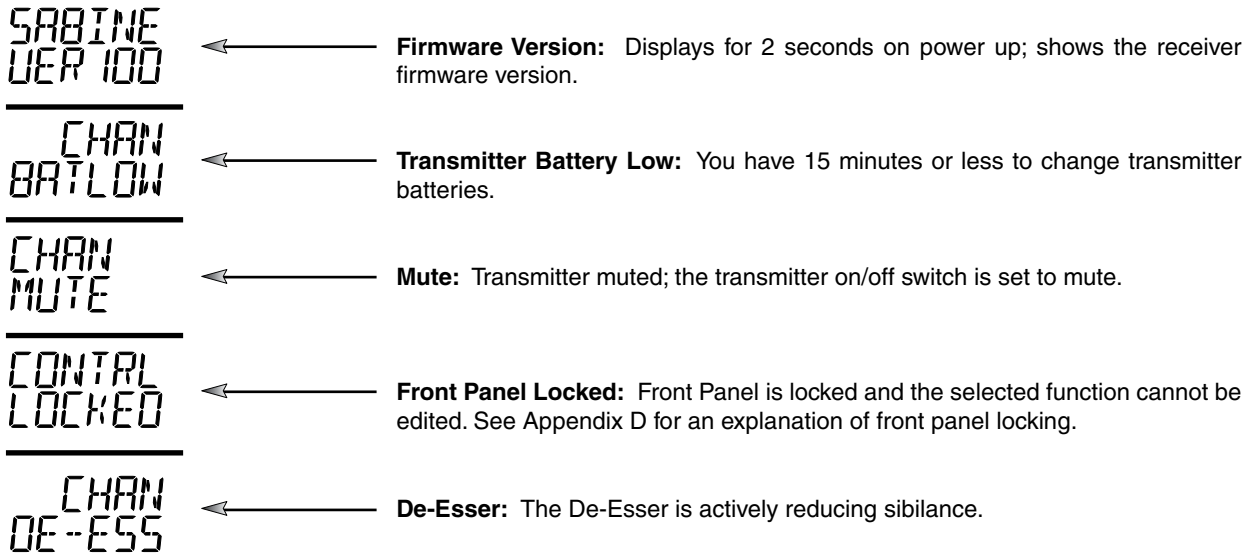


Fig. 5b: Receiver LCD Complete Display

Receiver LCD Status Bars



Function Display Messages



FBX, Lock and Edit Status Indicators

