

# Operational Description of HiLoV2 module

## 1. Block diagram

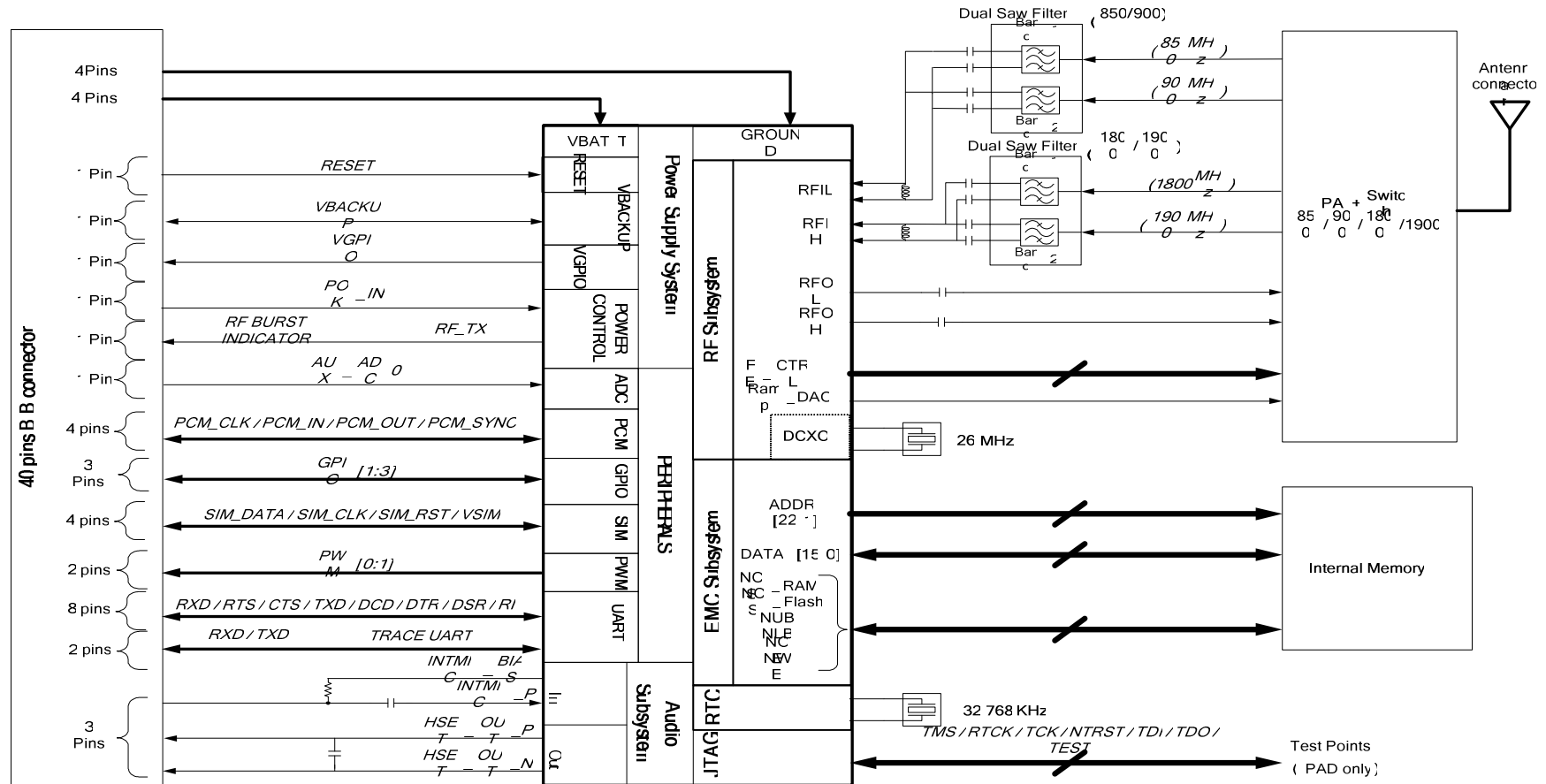

## 2. Functional description

### 2.1 Power supply system

The power supply system includes: VBAT, VGPIO, VBACKUP, Reset and Power control (POK\_IN signal, RF burst indicator signal).

The VBAT is the power supply for the module. Its range is from 3.2V to 4.5V.

The VGPIO is the power supply output from the module. It is supplied for external circuits and its rated value is 2.8V.

The VBACKUP is the power supply of backup battery. It should be connected to a backup battery. If no backup battery is provided, a 10uF capacitor should be connected between VBACKUP and GND.

The reset signal is used to reset the whole module as the requirement.

The POK\_IN signal is used for powering up the module. When this signal is pulled down for a few seconds, the module will be powered up.

The RF burst indicator signal is used for indicating the RF burst. When the RF burst comes, it will be in high voltage level. Otherwise, it will be in low voltage level.

### 2.2 RF subsystem

The RF subsystem includes: internal RF circuit, one antenna connector and two antenna pads.

The internal RF circuit is inside the module and works for RF communication.

The antenna connector is used for the connection between the module and external antenna.

The two antenna pads are also used for the connection between the module and external antenna.

The antenna connector and antenna pads can not be used at the same time.

### 2.3 EMC subsystem

The EMC subsystem is inside the module and used for reading and writing system data.

## 2.4 RTC

There is a RTC crystal inside the module. It is used for real time counting.

## 2.5 JTAG

There are 9 JTAG pads in the module. They are for JTAG debugging and reserved for Sagemcom.

## 2.6 Peripherals

The peripherals include: ADC, PCM, GPIO, SIM, PWM and two UARTs.

The ADC allows external sensor analog input to the module.

The PCM is the digital audio interface which can be used for digital audio data communication with host CPU.

The GPIOs are used for controlling external circuits. There are 3 GPIOs in the module.

The SIM interface is used for SIM card connection. 3V or 1.8V SIM card can be connected to the module through this interface.

There are two PWMs in the module. PWM0 is dc PWMs and used for external LED driving. PWM2 is a buzzer PWM and used for driving buzzer.

A V24 full UART is provided in the module. With this UART port, the module can communicate with other processors.

A two-wire UART is reserved for Sagemcom. It is for debugging.

## 2.7 Audio subsystem

A single-end audio input signal and a pair of differential audio output signals are provided in the module. They are used for connecting microphone and receiver.