

SAGEMCOM

SX682 WiMAX

User Guide – User



This device works in a frequency band for which no general licence has been obtained from your National Authority for Frequency Management. Please contact your service provider or your National Authority for Frequency Management about licensing before putting this device into service.

Contents

For your safety	5
Safety precautions	5
Cleaning and care	5
Trademarks	5
Information on Specific Absorption Rate (SAR)	6
Information about the optional outdoor antenna	6
SX682 WiMAX	9
What is WiMAX?	9
SX682 WiMAX	9
Product features	10
Product overview	10
Connectors and LEDs	10
Installing the SX682 WiMAX	13
Choosing your location	13
System requirements	15
Connecting the SX682 WiMAX	16
Connecting the outdoor antenna	16
Connecting the PC	17
Connecting a telephone, fax machine or answer machine	18
Switching on the devices	18
Restarting and resetting the SX682 WiMAX	19
Rebooting the SX682 WiMAX	19
Returning the SX682 WiMAX to factory settings	20
Configuration with the Web browser	21
User interface	21
Launching the user interface	21
UI elements	23
Setting the language	24
Opening online Help	25
Menu structure	25
The Home page	26
Basic Setup Wizard	27
Starting the Basic Setup Wizard	27
Entering access data for the WiMAX network	27
Setting up Internet access	27
Selecting the antenna	28
Adjusting the antenna	28
Establishing a radio connection to a WiMAX network	28
Precisely aligning the antenna	30
Setting up VoIP access	32

Advanced Settings	33
Setting the operating mode	34
Configuring Internet access	35
Setting up the Internet Connection	35
Setting up DNS servers	36
Enabling or disabling the firewall	36
Port Forwarding	37
Opening the firewall for a selected PC (Exposed Host)	38
LAN configuration	39
Setting up Internet telephony (VoIP)	40
WiMAX configuration	42
Antenna selection	42
Administration	43
System password	43
Restoring factory settings	44
Restart	45
Updating the firmware	45
Status	46
Internet	47
Local network LAN	48
Telephony	48
Device status	49
Radio status	49
Using the SX682 WiMAX	51
Making a phone call or faxing with the SX682 WiMAX	51
Making calls via VoIP	52
Receiving VoIP phone calls	52
Telephone functions	52
Confirmation tones	58
Appendix	59
Troubleshooting	59
Other faults and problems	60
Before contacting customer service or your provider	61
Checking the connection to the SX682 WiMAX	62
Configuring the Web browser	63
Setting up an HTTP proxy	63
Allowing pop-up windows	64
Specifications	65
Outdoor antenna specifications (optional)	65
Putting into service	66
CE declaration	66

Contents

Open Source Software used in the product	67
Warranty regarding further use of the Open Source Software	67
Open Source Software used	68
Acknowledgements	68
Open Source Software Licenses	69
Glossary	75
Index	83

For your safety

- ▶ Please read the safety instructions carefully before putting into service.

Safety precautions

General safety instructions

- ◆ If you give the SX682 WiMAX to someone else, make sure you also give them its documentation.
- ◆ The SX682 WiMAX must only be used as described in these installation instructions.

Safety instructions for connection

- ◆ Only use the mains adapter supplied, as indicated on the underside of the SX682 WiMAX.

Safety precautions for the SX682 WiMAX

- ◆ The operation of medical appliances may be affected. Be aware of the technical conditions in your particular environment, e.g. doctor's surgery.
- ◆ The SX682 WiMAX and the antenna can interfere with the functioning of medical devices such as pacemakers. Keep at least 20 cm between the devices and the pacemaker. For more information, consult your doctor.
- ◆ The device may cause an unpleasant humming noise in hearing aids.
- ◆ Do not use the devices in environments with a potential explosion hazard, e.g. car paint shops, or in a humid environment (bathroom etc.).
- ◆ The Ethernet function (LAN socket, **LAN**) and the FXS function (analogue phone port, **Phone**) are designed exclusively for connection **inside** a building.

Cleaning and care

Wipe the SX682 WiMAX with a **damp** cloth (do not use solvent) or an antistatic cloth. **Never** use a dry cloth. This can cause static.

Trademarks

- ◆ Microsoft Windows 2000, Windows XP, Windows Vista and Internet Explorer are registered trademarks of the Microsoft Corporation.
- ◆ Mozilla Firefox is a registered trademark of the Mozilla Organization.

Information on Specific Absorption Rate (SAR)

This device meets the limits for protecting the health of the public from the effects of exposure to electromagnetic fields when it is operated in connection with the designated antenna(s) like described in the user manual.

Your device is a radio transmitter and receiver. It is designed and manufactured not to exceed the limits for exposure to emission from electromagnetic fields recommended by international guidelines from the International Commission on Non-Ionizing Radiation Protection (ICNIRP). These limits are part of comprehensive guidelines for the protection of the public and establish permitted levels of exposure to electromagnetic radiation for the population. The guidelines were confirmed by independent scientific organisations through periodic and thorough evaluation of scientific studies. The limits include a substantial safety margin designed to assure the safety of all persons, regardless of age and health.

The exposure limit employs a unit of measurement known as the Specific Absorption Rate, or SAR. The SAR limit stated in the international guidelines is 2.0 W/kg. Tests for SAR are conducted in all frequency bands with the device transmitting at its highest power level with minimum possible distance to the body. The actual SAR level of the device during operation with the designated antenna(s) is below the maximum value and is additionally decreased by a distance to the device. This is because the device is designed to operate at multiple power levels so as to use only the power required to enable seamless network connection.

Information about the optional outdoor antenna



Only one of the antennas listed on page 13 must be used.

The outdoor antenna must be installed and put into service by a qualified electrician.

- ▶ Only commence the outdoor work once you have taken all the necessary steps to make the location safe.

Be sure to observe the safety instructions.

Wall duct:

To connect the SX682 WiMAX to the outdoor antenna, the antenna cable must be fed through the wall to the outside of the building. It must be possible to make a suitable wall or window duct at or near the location of the SX682 WiMAX.

Setting up the antenna mast:

There should not be any obstructions (walls, trees etc.) in front of the antenna.

The best results will be obtained if the outdoor antenna is in sight of the WiMAX base station (cf. Fig. 1). →

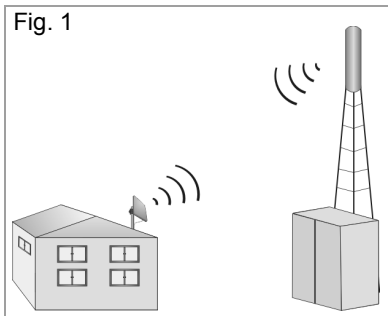

If a line of sight is not possible, you can reflect the radio waves off neighbouring buildings. To do this, direct the antenna at the building it is to reflect off and not at the base station (cf. Fig. 2).

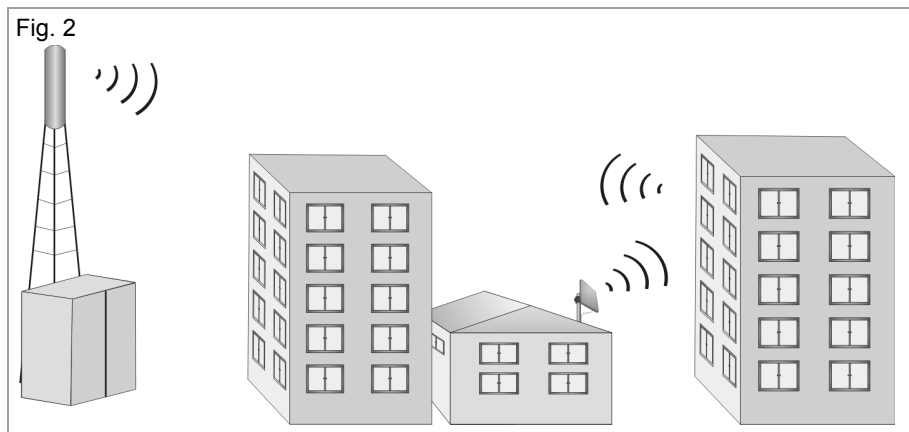

The antenna mast must be structurally secure. Check how secure the various attachments are.

The antenna mast must be within reach of the cable. Ideally, the antenna cable should be protected outside (from frost, sun, unauthorised and mechanical influences etc.).

In particular, make sure the antenna mast has sufficient load capacity. If you are mounting the mast on the roof, make sure the roof is fully sealed again afterwards.

Lightning protection

The antenna mast should be positioned near a lightning conductor. A suitable lightning conductor must be installed where necessary.

The outdoor antenna is not designed to be struck directly by lightning and must be protected accordingly. The antenna must therefore be mounted in areas that are protected against lightning (Lightning Protection Zone 0B). The corresponding separation distance (IEC 62305) must be complied with.

Earthing and lightning protection work may only be carried out by electricians specifically qualified for such work.

Information about the optional outdoor antenna

The appropriate earthing clamps must be used to create an equipotential bonding between a cable shield and an equipotential bonding bar that complies with regulations.

Please observe the standard DIN VDE 0855-300 and find out more on the Internet at <http://www.dehn.de>.

Antenna cable and antenna connection:

It must be possible to connect the outdoor antenna to the SX682 WiMAX by means of an antenna cable.

Please note that the antenna connection must be protected from the impact of rain and other weather effects.

Use cable clamps to attach the cable to the mast. Please note that the cable must be long enough to turn the antenna at a later stage.

Antenna alignment:

When aligning the antenna, we recommend asking a second person to run the Basic Setup Wizard on the PC and to check the reception quality on the screen; see Chapter "Basic Setup Wizard" on page 27.

Aligning the antenna using acoustic signals

If neither you nor the assistant are able to check the signal strength on screen while the antenna is being aligned, you can monitor it via a radio system. To do this you will need, for example, two cordless phones, mobile phones or radio devices:

i

- ▶ Activate **Tone on** on the configuration PC.
- ▶ Establish an internal connection between the two handsets and switch on the loudspeaker on both devices.
- ▶ Leave one handset next to the configuration PC and carry the other with you (belt clip).

You will now be informed of the signal strength by means of beeps. The closer together the sequence of beeps, the better the connection quality.

After installation:

Tighten all screw connections to the torques listed in the installation instructions.

Secure the antenna cable with cable clamps and cable ties. The cable must be protected from exposure to pressure and tension.

SX682 WiMAX

What is WiMAX?

WiMAX stands for "Worldwide Interoperability for Microwave **A**ccess", a modern wireless network technology that enables fast Internet connection even in remote areas. With WiMAX technology you are no longer dependent on a DSL infrastructure in your home or place of work. Instead, you connect your PC or network wirelessly to radio stations operated in your region by your provider. As a result, WiMAX gives you fast, economical broadband Internet access, even in places that are not connected to the DSL cable network.

The WiMAX standard IEEE 802.16 generally defines WiMAX technology. Your SX682 WiMAX already meets the latest IEEE 802.16e-2005 standard, a mobile WiMAX standard that offers many extra possibilities.

SX682 WiMAX

With your SX682 WiMAX, you can make use of everything the Internet has to offer:

◆ Downloads

- Even large files download quickly to your PC.
- Complex Website designs are no longer characterised by the time they take to download – you can enjoy flash animation and high-resolution graphics immediately after clicking a link.

◆ Audio

- Play back audio files straight from the Internet.
- Listen to the radio via the Internet in superb digital quality.

◆ Video

- View short or longer films you find on the Internet without tedious waiting times.
- Watch television via the Internet (IPTV).
- Use "Video on Demand" and order films that are transmitted to you via the Internet.

◆ Real time

- Take part in video conferences and feel as if you are sitting in the same room as the people you are talking to.
- Speak to and see your chat partners.

◆ VoIP

- Benefit from the economical telephone rates for Internet telephony (Voice over IP, VoIP). Your PC does not even need to be switched on.

Product features

- ◆ Wireless high-speed Internet access with a transmission rate of up to 20 Mbps (14 Mbps downlink, 6 Mbps uplink)
- ◆ Standard compatibility: IEEE 802.16e-2005
- ◆ Compatible with all current operating systems
- ◆ Suitable for home and business facilities
- ◆ Multi-protocol support: TCP/IP, FTP, HTTP and other Internet related protocols
- ◆ Easy to set up without installing software
- ◆ Internet and VoIP connection without the hassle of entering access data
- ◆ DHCP server and routing functions
- ◆ High performance and quality of service
- ◆ Optional: outdoor antenna for improved connection quality

Product overview

Connectors and LEDs

Connectors

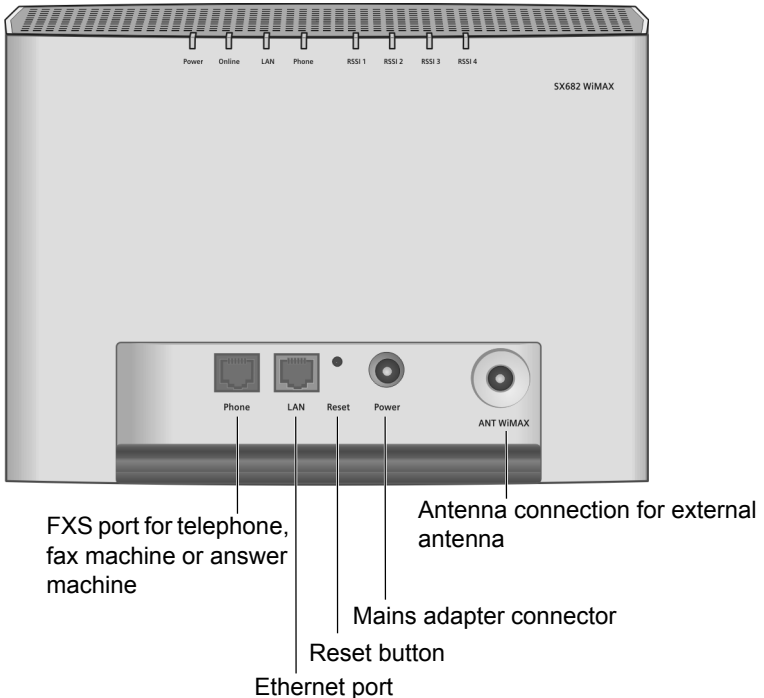

- ◆ For information about the optional outdoor antenna, please refer to "Connecting the outdoor antenna" on page 16.
- ◆ For information on connecting the mains adapter, please refer to "Switching on the devices" on page 18.
- ◆ For information on the reset button, please refer to "Restarting and resetting the SX682 WiMAX" on page 19.
- ◆ For information on the Ethernet port, please refer to "Connecting the PC" on page 17.

LEDs

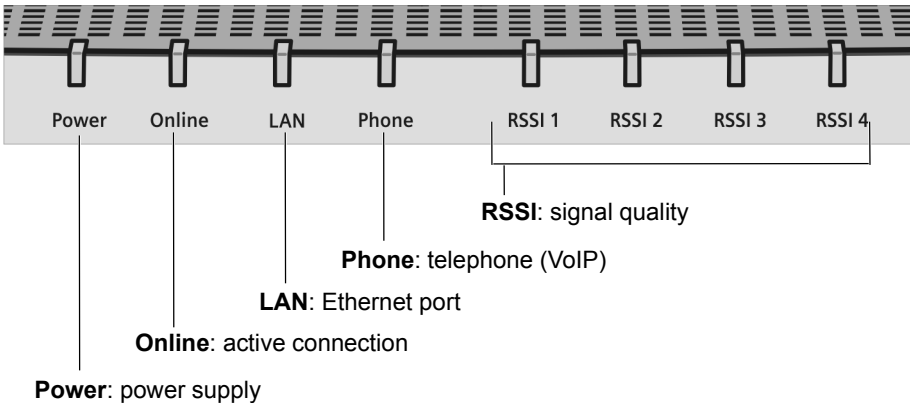

The LEDs indicate the status of the SX682 WiMAX and the current signal strength.

Name	LED	Meaning
Power: power supply	Lights up green	The SX682 WiMAX is powered correctly.
	Does not light up	The SX682 WiMAX is not powered correctly or the power supply has failed.
Online: active connection	Lights up green	The SX682 WiMAX is registered with a WiMAX network and ready for use.
	Does not light up	The SX682 WiMAX is not registered with a WiMAX network; it is not possible to establish an Internet connection.
	Flashes green	The SX682 WiMAX is establishing a connection with a WiMAX network.
	Lights up red	The SX682 WiMAX is not ready. Possible cause: device is overheating or faulty.
LAN: Ethernet port	Lights up green	Correct cable connection with a powered connection partner.
	Does not light up	No or incorrect cable connection.
	Flashes green	Data transfer via the Ethernet port.

Product overview

Name	LED	Meaning
Phone: telephone	Lights up green	The phone connection is active and registered with a VoIP provider. You can make calls via the Internet.
	Does not light up	The telephone connection is not active or not registered with a VoIP provider. You cannot make calls via the Internet.
	Flashes green	The connected telephone is active: it is being used to make a call or there is an incoming call.
RSSI: signal quality	0 to 4 LEDs light up green	The LEDs on the SX682 WiMAX help you to position the antenna more easily. The LEDs indicate the signal quality; the more LEDs that light up, the better the signal reception.
	All 4 LEDs flash green	The SX682 WiMAX is being reset to the factory settings; see "Returning the SX682 WiMAX to factory settings" on page 20.

<i>i</i>	<p>The connection quality can be detected in two different ways:</p> <ul style="list-style-type: none"> ◆ CINR (Carrier to Interference and Noise Ratio) measures the signal quality. ◆ RSSI (Received Signal Strength Indication) measures the signal strength. <p>The LEDs indicate either RSSI or CINR values. The used method is pre-configured by your operator. If RSSI is used the RSSI 1 - RSSI 4 LEDs will show the signal strength.</p>
-----------------	--

Installing the SX682 WiMAX

The SX682 WiMAX can only be used with the device's integrated antenna or with one of the following outdoor antennas:

3.5 GHz	18 dBi	WiMAX	Antenna Outdoor	"Antenna cable 3 m"
2.6 GHz	15 dBi	WiMAX	Antenna Outdoor	"Antenna cable 3 m"

	<p>3.5 GHz versions should be used for the European Economic Area. The following requirements apply: All the external antennas used for this product must undergo a conformity assessment procedure. The 3.5 GHz antennas listed here meet the European requirements and guarantee the functionality of the complete system. During the conformity assessment procedure it was ensured that the SAR limits set down in directive 99/519/EC are observed. Verification was performed using EN 50385.</p> <p>The outdoor antenna must be installed and put into service by a qualified electrician. The notes in the enclosed installation instructions must be followed.</p>
---	---

This user guide assumes that installation of the outdoor antenna has been completed.

Choosing your location

- ◆ Choose a location that enables you to simply set up the following connections without any further work.
 - Connect the Ethernet cable for connection to a PC or network.
 - Connect the power lead to the mains socket.
- ◆ Stand the SX682 WiMAX upright on an even, non-slip surface.
- ◆ Lay the cables in such a way that nobody can tread on or trip over them.
- ◆ Position the SX682 WiMAX so that you can see the LEDs.
- ◆ Do not cover the openings in the SX682 WiMAX housing to ensure the heat can circulate; otherwise, the duty cycle of the device will be reduced or the SX682 WiMAX switched off to avoid overheating.
- ◆ Do not operate the SX682 WiMAX under the influence of direct heat sources (e.g. directly in the sun).

Choosing your location

If you use the integrated antenna:

- ◆ Position the SX682 WiMAX directly in a window, so that the side with the LEDs and connectors is pointing into the room, towards you. Wherever possible, position the SX682 WiMAX on one of the upper storeys. Note that obstructions, particularly doors and wall coverings containing metal can affect data transmission.
- ◆ Position the SX682 WiMAX as far away as possible from metallic objects and coated foils.

SX682 WiMAX with integrated antenna

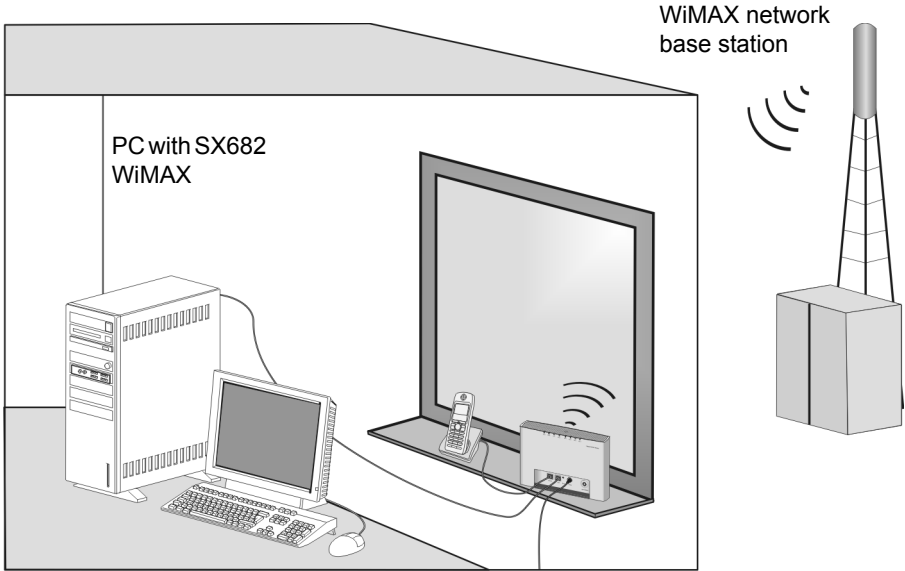

SX682 WiMAX with outdoor antenna

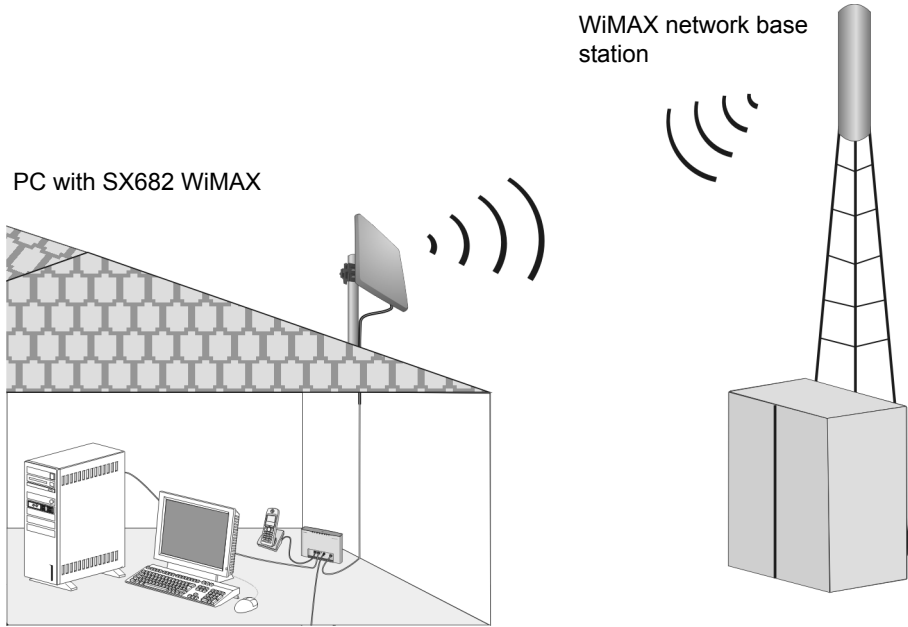

When used with the integrated antenna or the outdoor antenna, the SX682 WiMAX complies with the regulations on limiting the effect of electromagnetic fields on the general population.

System requirements

To use the SX682 WiMAX, the following requirements have to be fulfilled.

- ◆ You will need a PC that meets the following requirements:
 - PC with a free LAN interface 10/100BaseT (network adapter). The network adapter on the configuration PC must support one of the following modes: 10BaseT Half Duplex, 10BaseT Full Duplex, 100BaseT Half Duplex, 100BaseT Full Duplex. The TCP/IP protocol has to be set up on the PC (standard installation for Windows XP and Windows Vista; if you are using a different Windows operating system, read the separate instructions on network configuration, if necessary).
 - A Web browser is installed on the configuration PC (e.g. Internet Explorer or Mozilla Firefox).
- ◆ To access the Internet you will need to register your SX682 WiMAX with a WiMAX Internet provider. To use Internet telephony, your provider will need to register a VoIP account for your SX682 WiMAX.

Connecting the SX682 WiMAX

Connect the SX682 WiMAX in the following order:

1. If you use the outdoor antenna, have it installed by a qualified electrician. Connect the antenna cable from outside to the SX682 WiMAX.
2. Connect the PC to the SX682 WiMAX.
3. Connect an analogue terminal (telephone, fax machine, answer machine).
4. Connect the SX682 WiMAX to the mains power supply and switch all the devices on.

Connecting the outdoor antenna

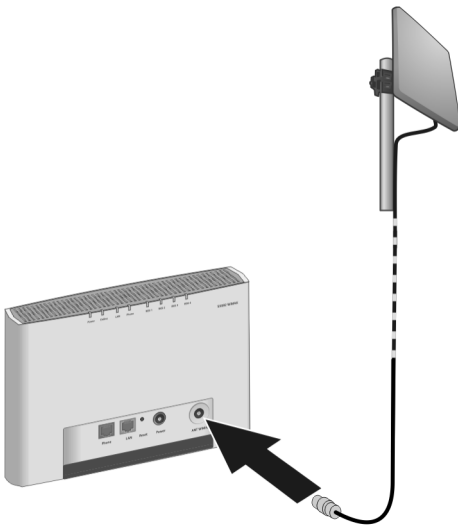

- ▶ Screw the connector of the antenna cable into the **ANT WiMAX** connector on your SX682 WiMAX. In order to disconnect the antenna cable from the connector, open the screw connection.

Connecting the PC



Use either the Ethernet cable that is supplied or a standard network cable (CAT-5) to connect the device to the PC. It is not important whether the Ethernet cable has straight or crossed wiring.

Always use a shielded Ethernet cable.

Connecting SX682 WiMAX to the PC

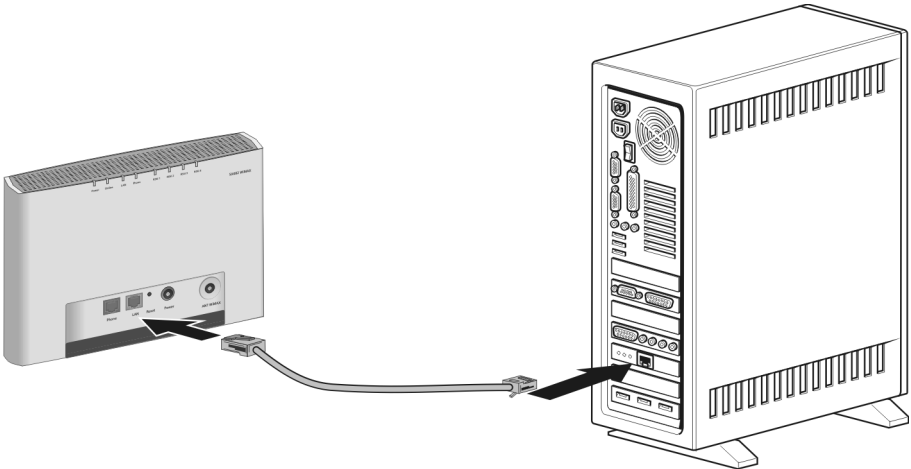

- ▶ Connect one Ethernet cable plug to the Ethernet port on the SX682 WiMAX.
- ▶ Connect the other plug of the Ethernet cable to the LAN interface on the PC.

Optional: connecting several terminals

If you wish to connect several terminals (for example a PC and a laptop) and establish an Internet connection with all the devices, connect a switch or hub to your SX682 WiMAX.



A DHCP server is integrated into your SX682 WiMAX. Please ensure that a second DHCP server is not activated on your server. For details on this, read the operating instructions for your switch/hub.

Connecting the SX682 WiMAX

Connecting a telephone, fax machine or answer machine

You can connect an analogue terminal, such as a telephone with cord, cordless telephone, fax machine or answer machine, and operate them via the Internet in future (Internet telephony/VoIP).



Depending on the connection plug on your analogue terminal, you may require an additional adapter (TAE socket on the RJ11 plug).

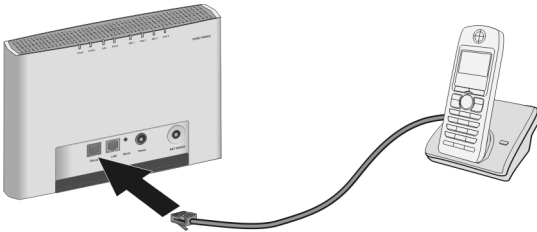

- ▶ Connect the plug on the analogue terminal to the **Phone** connection on the SX682 WiMAX.

If your analogue terminal has a TAE plug, first connect this to the adapter (connect a telephone to the F-coded socket, a fax machine or answer machine to the N-coded socket). Then connect the adapter plug to the **Phone** connection on the SX682 WiMAX.

- ▶ If necessary connect the telephone, fax machine or answer machine to the mains power supply.

Switching on the devices



Only use the SX682 WiMAX with the mains adapter supplied.

- ▶ Connect the mains adapter plug to the SX682 WiMAX socket.
- ▶ Power up the PC.
- ▶ Connect the mains adapter to the mains power supply.

The system starts up and performs a self-test. After the self-test, the SX682 WiMAX continually attempts to register with a WiMAX network. Registration may be successful immediately. If not, registration will take place when the SX682 WiMAX is being configured.

- ▶ Check the LEDs during startup:

LEDs during startup:

- The **Power** power supply LED lights up **green**, and the SX682 WiMAX starts a self-test. If the LED does not light up, check that the mains adapter is connected correctly and the power socket is live.
- The **LAN** Ethernet LED is continuously lit **green**. If the LED does not light up, check that the Ethernet cable is connected correctly.
- If registration with a WiMAX network has already been successful, the **Online** LED lights up **green**. If the LED does not light up, register your SX682 WiMAX during configuration.

Restarting and resetting the SX682 WiMAX

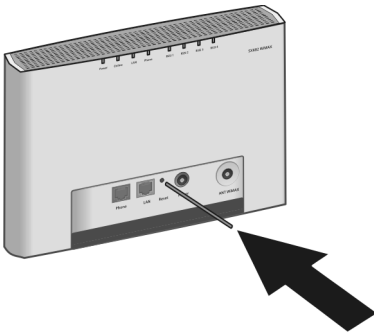

The reset button is located inside the SX682 WiMAX so that it cannot be pressed accidentally. If you need to restart or reset the SX682 WiMAX, use a thin object such as an opened up paper clip.

Rebooting the SX682 WiMAX

- ▶ Briefly press the reset button (for less than 5 seconds). The configuration settings will remain, the SX682 WiMAX will be restarted.

You can also restart the SX682 WiMAX via the user interface or by briefly cutting the power supply.

Returning the SX682 WiMAX to factory settings

If you no longer have access to your SX682 WiMAX, you can also restore factory settings with the reset button on the back of the device.



When the factory settings are restored, all personal settings are deleted.

- ▶ Press and hold the reset button for more than 5 seconds.

The 4 **RSSI** LEDs will begin to flash green. The configuration settings are returned to the factory settings and the SX682 WiMAX is restarted. This process takes about 25 seconds. The SX682 WiMAX will then automatically try to set up a connection to a WiMAX network; depending on the connection quality, 0 to 4 **RSSI** LEDs will permanently light up green.

Factory settings

After restoring the factory settings, your SX682 WiMAX will be in its original condition:

- ▶ Proceed as follows to start operating your device again:

Menu

Setting

Basic Setup Wizard

Execute the Basic Setup Wizard to configure your device and to establish a connection to the WiMAX network, see "Basic Setup Wizard" on page 27.

Advanced Settings – Administration – System Password

Protect the configuration interface of your device with a password, see "System password" on page 43.

If the device came from your provider with a preset system password, this will now be valid again. Please check the documents supplied by your provider.

Configuration with the Web browser

You do not need to install any software on your PC to configure your SX682 WiMAX; the configuration program is stored on the device. Open this software in the same way as an Internet page in the Web browser and make the required settings. Your settings are then stored directly on the device.

On startup, the Basic Setup Wizard helps you set up a connection to the WiMAX network and configure your Internet access.



For experienced users:

- IP address: 192.168.2.1
- Subnet mask: 255.255.255.0

Presentation of the configuration program

To configure your SX682 WiMAX, we recommend the Microsoft Internet Explorer version 7.0 or Mozilla Firefox version 2.0 or their higher versions. However, you can also use most other or older Web browsers.



Number and amount of the functions and settings provided by the configuration program may differ specific to a project.

User interface

Launching the user interface

- ▶ Open your Web browser.
- ▶ Enter the IP address of your SX682 WiMAX in the address field of your Web browser:

`http://192.168.2.1`

- ▶ Press Enter (Return).

If a system password has been set up on your SX682 WiMAX, the login screen will now open.

- ▶ Enter the system password supplied by your provider in the text box and click **Ok**.

The start page (Home) of the user interface opens, in which you can change the language if necessary (→ page 24).

Change the system password later to one of your own (see "System password" on page 43).

If no system password has been set up on your SX682 WiMAX, a security warning will appear first. You should then assign a system password as soon as possible.

- ▶ Confirm the security warning with **Ok**.

User interface

The user interface start page opens.

If the login screen does not open:

- ▶ Check the connections; see "Connecting the SX682 WiMAX" on page 16.
- ▶ If you use a firewall on the PC, it must allow connection to the SX682 WiMAX. If applicable, switch off the firewall for a test; if you can then open the login screen, configure the firewall accordingly. For details, refer to the user guide for your firewall.

If you have changed the standard settings on your PC, you might not be able to open the configuration pages.

- ▶ For details on how to find and rectify the fault, see "Fault tracing" on page 59.

Saving the user interface address

- ▶ You can add the address of the login screen to your favourites/bookmarks so that you will no longer need to enter the IP address manually in future:
 - Internet Explorer: **Add to Favorites** button
 - Firefox: **Bookmarks > Add Bookmark**

UI elements

The user interface you open with the Web browser is divided into the following sections:

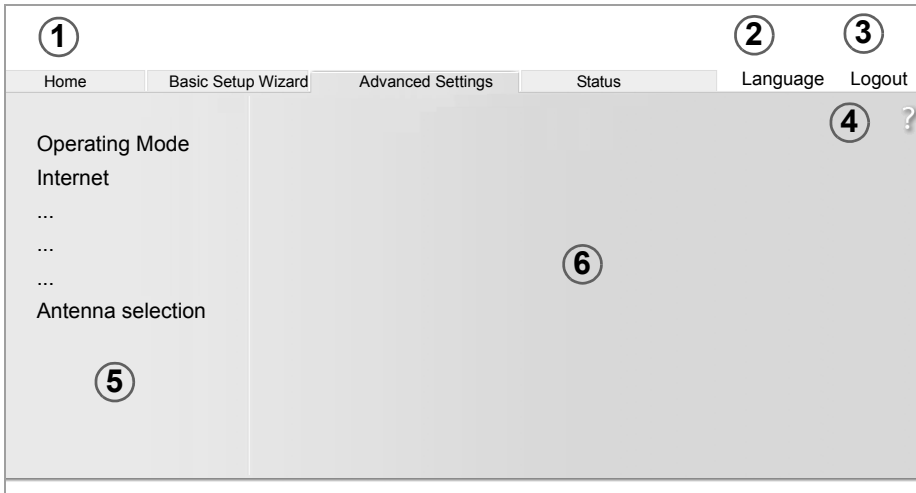

- 1 Tab selection:**
Open the **Home**, **Basic Setup Wizard**, **Advanced Settings** or **Status** tabs to display the contents of each configuration area.
- 2 Language button:**
Select your language. This button is only available on the **Home** screen.
- 3 Logout button:**
This button is only displayed if a system password is set up.
Log off from your SX682 WiMAX.
- 4 Open Help window button:**
Open the online Help relating to the menu item currently in the working area.
- 5 Menu area:**
Click the menu items to display the respective pages of the currently open configuration area or a submenu.
- 6 Working area:**
Check the settings on your SX682 WiMAX and change them as necessary.

User interface

Buttons



Open online Help.

Click this button if you require information about the screen you currently have open. The corresponding Help topic is opened.

Logout

Button with which you end the connection between the PC and the SX682 WiMAX.

Back

Return to the previous screen in the Basic Setup Wizard.

Next

Move on to the next screen in the Basic Setup Wizard.

Cancel

Changed settings are not applied and you return to the highest level.

Ok

Save the settings and return to the highest level.

End

Save the settings and exit the Basic Setup Wizard.

You will see other buttons depending on the screen currently open. If you require further information about these, open the online Help at the appropriate place using the question mark button.

Input fields

On the configuration screens, change the required settings using the following input fields:



Option buttons:

Two or more buttons, of which one is activated. As soon as you click another option button, it is activated and the one previously selected is reset. You will find option buttons wherever there is a choice between several possibilities, e.g. whether or not you wish to use an external or the internal antenna.



Text field:

Enter text or digits. Click in the field to activate input mode. You will find text fields at points where you can specify text or numbers as required, e.g. a new system password.



Setting the language

The user interface is initially displayed in the language that has been set by your operator. Other languages may be available.

- ▶ If you wish to change the preset language, click on the **Language** button at the top right. This opens the page for setting the language.
- ▶ Click the arrow next to the selection field to open it and select your language.
- ▶ Click **Ok** to change the language.

Opening online Help

There is an online Help for each screen of the configuration program, which you can open directly on the screen.

- ▶ Click the question mark button at the top right.
The online Help is shown in the right pane of the configuration program.
- ▶ If necessary, click **Open Help window** to open the online Help in a separate window.

Menu structure

The menu of the user interface on your SX682 WiMAX is split into the following main areas: **Home**, **Basic Setup Wizard**, **Advanced Settings** and **Status**. Under these menu options, you will find the following areas:

Menu	Description
Home	Start page and starting point for all configuration and administration tasks. It also shows the connection status and allows you to set the language, see "User interface" on page 21.
Basic Setup Wizard	Establish a connection to the WiMAX network, optimise the antenna direction and set up your Internet connection and VoIP access, see "Basic Setup Wizard" on page 27.
Advanced Settings	Configure your Internet and VoIP access and your local network and perform administration tasks. For example, you can enter a system password for access to your SX682 WiMAX or change it, see "Configuration with the Web browser" on page 21.
Status	Obtain information on the operating status of your SX682 WiMAX and read off the device and version numbers as well as IP addresses; see "Status" on page 46.
	Internet See "Internet" on page 47.
	Local Network See "Local network LAN" on page 48.
	Telephony See "Telephony" on page 48.
	Device Status See "Device status" on page 49.
	Radio Status See "Radio status" on page 49.

The Home page

Once you have logged in successfully to the SX682 WiMAX, you will see the **Home** page for the device software. The start screen offers an overview of all areas of the configuration program:

Menu	Description
Basic Setup Wizard	Perform the basic configuration and set up the radio connection to the WiMAX network (→ page 27).
Advanced Settings	Perform advanced configuration and administration tasks (→ page 33).
Status	Obtain information on the status of your SX682 WiMAX (→ page 46).

In the area to the right of the start screen, you will see the connection status of your SX682 WiMAX:

- ◆ **connected** = The SX682 WiMAX has established a radio connection with a WiMAX network. You will see the connection duration in brackets and in the format ddd:hh:mm:ss (d=days, h=hours, m=minutes, s=seconds).
- ◆ **disconnected** = The SX682 WiMAX is trying to establish a connection with a WiMAX network.

To configure your SX682 WiMAX, use the Basic Setup Wizard, which will help you establish a radio connection.

Connecting to the Internet manually

Once you have configured your Internet access (see page 27 and page 35), you can establish a manual connection to the Internet on the start screen if you have selected **Connect on demand** as the Connection mode.

To establish or end an Internet connection manually:

- ▶ Open the start screen of the SX682 WiMAX as described on page 21.
- ▶ If you have already started the user interface, click the **Home** tab at the top left of the window.
- ▶ Click **Connect** to establish a connection to the Internet.
- ▶ Click **Disconnect** if you no longer require the connection.

Basic Setup Wizard

The Basic Setup Wizard helps you start up your device and guides you step by step through the configuration process with the most important settings.

The Basic Setup Wizard comprises the following steps:

- ◆ Entering the access data for the WiMAX network
- ◆ Configuring the Internet access
- ◆ Selecting the antenna
- ◆ Positioning the device
- ◆ Scanning the frequencies to establish a radio connection with a WiMAX network
- ◆ Exact alignment of the antenna to optimise the quality of the connection
- ◆ Configuring VoIP access



You can check all the configuration settings that you make with the Basic Setup Wizard later via the Advanced Settings menus and, if necessary, change them, see "Advanced Settings" on page 33.



Depending on the pre-configuration of your device some of the menu entries and configuration possibilities might be missing in your device.

Starting the Basic Setup Wizard

- ▶ To start the Basic Setup Wizard, click the **Basic Setup Wizard** tab.
- ▶ Click **Next**.

Entering access data for the WiMAX network

On this page you enter the data for authentication of your device on the WiMAX base station. You will need the access data supplied by your WiMAX operator for this.

- ▶ Activate the **Authentication** option, if this is required by your WiMAX operator.
- ▶ Enter the access data and click **Next**.

Setting up Internet access

To allow users in your local network access to the Internet, set up the Internet connection of your device using the information supplied by your Internet provider.

- ▶ Enter the access data and click **Next**.



Your SX682 WiMAX can be used as an Internet router or bridge. For more on this see "Setting the operating mode" on page 34.

Selecting the antenna

- ▶ Select whether you want to operate your SX682 WiMAX with an outdoor antenna or the integrated one.
 - Click the first option button if you want to use the integrated antenna. Your SX682 WiMAX must be positioned by the window with the cable connections pointing inwards and must be connected.
 - Click the second option button if your SX682 WiMAX came with an outdoor antenna. This antenna must have been installed and connected by an electrical specialist.
- ▶ Click **Next**.

Adjusting the antenna

- ▶ If you are using the integrated antenna, adjust your SX682 WiMAX by the window. If you are using the outdoor antenna, this must already be installed and facing towards the base station, see "Installing the SX682 WiMAX" on page 13.
- ▶ Click **Next**.

Establishing a radio connection to a WiMAX network

The Basic Setup Wizard will now scan the frequencies to establish an initial radio connection to a WiMAX network.

The frequency scan begins automatically. A progress bar indicates how far the scan has progressed. In addition, you will see in the **Remaining time** area roughly how much time is still needed for the complete scan. Depending on how your SX682 WiMAX has been preconfigured by your provider, the scan can last several minutes before the first radio connection is established.



During the scan, the SX682 WiMAX or antenna must not be moved; this is the only way to guarantee a complete scan with the current antenna alignment.

As soon as a radio connection has been established with a WiMAX network, the scan will end. The progress bar is fully filled in and the display in the **Remaining time** area jumps to **0 seconds**.

- ▶ If the scan has been successful, read on in Chapter "Precisely aligning the antenna" on page 30.

If the scan was not successful:

Both the integrated antenna and the outdoor antenna are directional antennas; this means that they must at least be pointing roughly in the direction of a WiMAX network base station in order to establish a radio connection. The access data must also have been entered correctly.

If the scan was not successful:

- ▶ First check your access data by going back to the WiMAX configuration page (→ page 27).
- ▶ If you have entered your access data correctly, adjust the antenna.

If you are using the integrated antenna:

- ▶ Turn your SX682 WiMAX by approx. 45°.

Correct:



Incorrect:

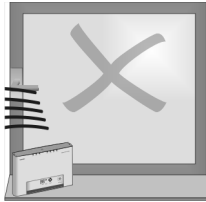

- ▶ Click **Ok** to restart the scan.



You must not move the SX682 WiMAX during the scan. You should therefore always place the SX682 WiMAX upright and on a level surface directly by the window.

If the scan has still not been successful with the alignment changed:

- ▶ Place the SX682 WiMAX by a window that faces a different direction.
- ▶ If necessary, repeat the scan with all possible locations and alignments.
- ▶ If necessary, ask your provider for the location of the nearest WiMAX network base station and select a location for your SX682 WiMAX that points towards this base station.

The best results will be obtained if the SX682 WiMAX is in sight of a WiMAX network base station.

Basic Setup Wizard

If a line of sight is not possible, you can reflect the radio waves off neighbouring buildings. To do this, direct the SX682 WiMAX at the building it is reflecting off and not at the WiMAX network base station.

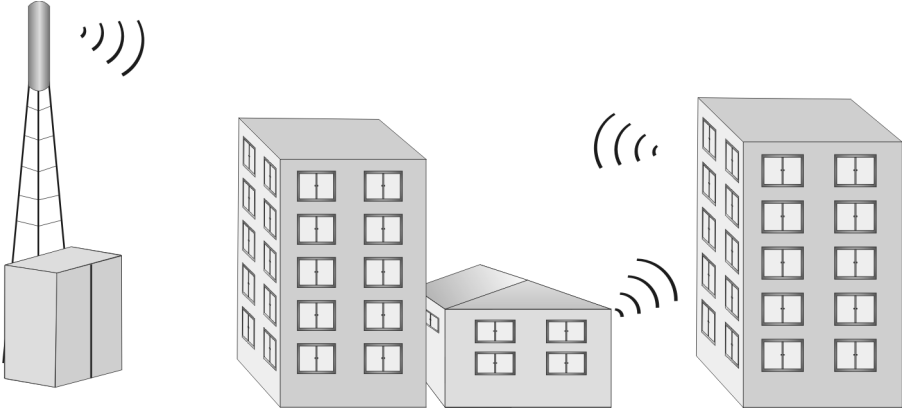

If you are using the outdoor antenna:

- ▶ The qualified electrician turns the antenna through 20° in the vertical axis. Then the scan is repeated by clicking the **OK** button.
- ▶ If necessary, the scan should be repeated with all possible antenna alignments.

Precisely aligning the antenna

Once you have established a radio connection to a WiMAX network, align your SX682 WiMAX or antenna precisely using the Basic Setup Wizard.



Take extra care to align the SX682 WiMAX or outdoor antenna precisely. The better the connection quality, the faster your Internet connection will be in the future.

To obtain precise alignment of the SX682 WiMAX or antenna, turn it a little at a time. If you use the antenna integrated in the SX682 WiMAX, you can also move the device a little at a time to optimise the reception quality.

- ▶ When a connection to a WiMAX network has been established, click **Next** to make fine adjustments to the antenna.

The quality of the radio connection is represented graphically by the **Signal quality** bar. The longer the bar is, the better the radio connection. Try to obtain the best possible radio connection setting.

- ▶ If you are using the antenna integrated in the SX682 WiMAX:
Memorise the current location and alignment of your SX682 WiMAX, so that you can restore it if the connection is broken.
- ▶ If you are unable to check the display of the signal quality on the screen while aligning the antenna:
Activate the **Audible feedback** option to obtain information about the signal quality by means of beeps. The closer together the sequence of beeps, the better the connection quality.
- ▶ Turn or move the SX682 WiMAX or turn the antenna a little at a time and note the signal quality display. Use this to move the antenna to the position with the best signal quality.

In addition to the beeps and on-screen bar graph you can also determine the quality of the connection by how many of the 4 LEDs indicating signal quality are lit up on the device (**RSSI 1–RSSI 4**). The more LEDs that light up, the better the connection quality.

If you have turned your SX682 WiMAX or the antenna too far, the connection might break. You should then return to the alignment that provided a connection and repeat the procedure for establishing a connection to the WiMAX network. Then make any fine adjustments step by step.

i	<p>The connection quality can be detected in two different ways:</p> <ul style="list-style-type: none"> ◆ CINR (Carrier to Interference and Noise Ratio) measures the signal quality. ◆ RSSI (Received Signal Strength Indication) measures the signal strength. <p>The bar indicates either RSSI or CINR values. The used method is pre-configured by your operator. If RSSI is used the bar is labeled Signal strength.</p>
----------	--

When your SX682 WiMAX or outdoor antenna is optimally aligned:

- ▶ Click **Next**.

Make sure that in future your SX682 WiMAX or outdoor antenna is always in the set position.

Setting up VoIP access

If you have connected an analogue telephone to the **Phone** port of your device for Internet telephony, you set up your VoIP account here using the information you received from your VoIP provider.

- ▶ Activate the **VoIP** option to use Internet telephony for your device.
- ▶ Enter the access data for your VoIP account that you received from your VoIP provider. You can normally keep the default settings, unless your provider explicitly requires other values.

You can enable or disable the following options:

Comfort noise generation

In digital voice transmission, CNG (Comfort Noise Generation) ensures that the listener hears a slight background noise in the pauses between speech, otherwise they might think the connection has been lost.

Out-of-band DTMF

With analogue phones, DTMF (Dual-Tone Multi-Frequency, a multi-frequency dialling system) is used to dial a number or transmit digits during a connection. There are two kinds of DTMF:

Out-of-band: DTMF digits are transmitted in the voice-frequency band (above G.711).

In-band: DTMF digits are transmitted through RFC 2833 signalling (e.g. when retrieving an external voicemail).

- ▶ If you want to clear all the occupied fields on this page, click **Clear**.
- ▶ Click **End** to close the Basic Setup Wizard and apply the settings you have made.



Further features as **Call waiting**, **Call forwarding** and **Call transfer** can be configured in the **Advanced Settings** menu on the **Telephony** page.

For more detailed information on the telephone functions, see section "Making a phone call or faxing with the SX682 WiMAX" on page 51.

Advanced Settings

In the **Advanced Settings** menu, you can configure all the options for the SX682 WiMAX. If required, you can also change the settings you made using the Basic Setup Wizard. The following table contains the options available in this menu.

Menu	Description
Operating Mode	Here you can define whether your SX682 WiMAX will be used as a router or a bridge for the Internet access (page 35).
Internet	Here you can configure your Internet access. This menu covers all setting options for the Internet (page 35).
Local Network	Here you can configure your local network, e.g. change the private IP address of the SX682 WiMAX or make settings for the DHCP server (page 39).
Telephony	Here you can configure your access for Internet telephony (VoIP) (page 40).
Administration	Here you can do various administration tasks, e.g. assign a system password (page 43) or reset the configuration to the factory defaults (page 44). You can also load new firmware (page 45)
WiMAX configuration	Here you can change the access data for your WiMAX access (page 42).
Antenna selection	Here you can choose whether to use the internal antenna or an outdoor one for your WiMAX access (page 42).

All Advanced Settings pages contain **Ok** and **Cancel** buttons.

- ▶ Click **Ok** to confirm your entries.
- ▶ Click **Cancel** to close a page without applying the changes.

<i>i</i>	Depending on the pre-configuration of your device some of the menu entries and configuration possibilities might be missing in your device.
-----------------	---

Setting the operating mode

Via the operating mode, you define the role your SX682 WiMAX will play when establishing and administering Internet connections.

You can run your SX682 WiMAX in the following operating modes:

- Router** Your SX682 WiMAX serves as an Internet router for the network components connected to the LAN port, i.e. it establishes the connection to the Internet and ensures the transfer of the communication data to and from the Internet (default).
- Bridge** The network components initiate and control their Internet connection themselves. Your SX682 WiMAX only allows the communication data to and from the Internet to pass through.

- ▶ To change the operating mode, open the **Advanced Settings** tab and select **Operating Mode** from the menu.

When you change the operating mode, your device is restarted.

In **Bridge** mode, the following functions are no longer available:

- ◆ The DHCP server of the SX682 WiMAX is deactivated (→ page 39) because the network components receive IP addresses in the public network.
If you want to access the configuration program of the SX682 WiMAX via your PC, you must connect the PC directly to the LAN port. You must also temporarily assign it a static IP address in the address range of the SX682 WiMAX. If you want to use the Internet again after this, reset your PC to “automatic IP address”. For details see the document “Configuring the local area network” on the product CD.
- ◆ The firewall of your SX682 WiMAX is disabled and cannot be enabled (→ page 36).
- ◆ The NAT function of your SX682 WiMAX is disabled. This means that the functions Port Forwarding (→ page 37) and Exposed Host (→ page 38) are not available.

If necessary you may have to protect your network components against unwelcome access from the Internet by appropriate means (e.g. firewall software).

Configuring Internet access

If you have configured the SX682 WiMAX using the Basic Setup Wizard, you have also configured your Internet access. You can check or change these settings in the **Internet** menu.

This menu also offers you a wide range of possibilities for setting up security settings and limiting access to the Internet as well as for providing your own services on the Internet.

You can carry out the following via the **Internet** menu:

Internet Connection	Check and edit the Internet connection of the SX682 WiMAX (for further information see below),
DNS Servers	Make DNS server settings (→ page 36),
Firewall	Protect the network against hacker attacks (→ page 36),
Port Forwarding	Provide your own services on the Internet (→ page 37),
Exposed Host	Opening the firewall for a selected PC (→ page 38).

Setting up the Internet Connection

You can set up or change the configuration of your Internet connection in this screen. All the settings you make here must coincide with the features your Internet service provider makes available to you. Incorrect information can lead to problems with your Internet connection.



Depending on the pre-configuration of your device some of the following configuration possibilities might be missing in your device.

- ▶ Open the **Advanced Settings** tab and on the **Internet** menu select **Internet Connection**.
- ▶ Enter the data you have been given by your service provider.
- ▶ Select the **Protocol** used for Internet access.
 - **PPPoE**
 - **Static**
 - **Obtain automatically**
- ▶ Apply the default settings for the other parameters unless your service provider has given you other data.

Connection mode

For a PPPoE connection (Point-to-Point over Ethernet), specify the **Connection mode**:

Configuring Internet access

Always on

This gives the users in your network a constantly active Internet connection. Only choose this setting if your Internet tariff is not time-dependent.

Choose this option if you use Internet telephony, otherwise you cannot receive incoming calls.

If necessary you can terminate the Internet connection manually (→ page 26).

Connect on demand

The Internet connection is only established if an application, e.g. an Internet browser or an e-mail program, requests it.

PPPoE pass-through

If you activate the **PPPoE pass-through** function, a PC in the network can connect to the Internet via its own connection ID. The router puts this connection through.

Setting up DNS servers

DNS (Domain Name System) is a decentralised database on the Internet which allocates clearly understandable Internet names (domains) to the actual addresses of PCs and services (e.g. IP addresses). The DNS servers required for access to this database are normally provided by your provider and do not have to be set up specially. But if necessary you can change them here.

- ▶ Open the **Advanced Settings** tab and on the **Internet** menu select **DNS Servers**.
- ▶ Activate the **Use custom DNS servers** function and enter the IP addresses for your **Preferred DNS server** and the **Alternate DNS server**.

Enabling or disabling the firewall

Your SX682 WiMAX comes with an integrated firewall, which protects your device and network against unauthorised access from the Internet. If the firewall is enabled, your device can identify certain events, e.g. suspicious incoming data packets from the Internet, as attacks and avert them (hacker defence). Your device's firewall is enabled by default.



We urgently recommend that you leave the firewall of your SX682 WiMAX enabled, otherwise your network will no longer be protected against hacker attacks from the Internet.

If you still want to disable the firewall:

- ▶ Open the **Advanced Settings** tab and on the **Internet** menu select **Firewall**.
- ▶ Disable the firewall.



This function is not available in **Bridge** operating mode, see "Configuring Internet access" on page 35.

PCs in your network should be protected by a separate firewall. You can set up protection against DoS (Denial of Service) attacks in Bridge mode via the local network configuration, see "LAN configuration" on page 39.

Port Forwarding

The SX682 WiMAX comes with the NAT (Network Address Translation) function, which is always activated in Router operating mode. With address mapping, multiple users in the local network can access the Internet via the public IP address. All the local IP addresses are assigned to the router's public IP address by default. All IP addresses of PCs in the local network are converted to the router's public IP address when accessing the Internet.

Most Internet applications can be executed behind the NAT firewall without any problems. However, some applications - such as Internet games - require users in the Internet to send requests to users in the local network so that the players can communicate with each other. Sometimes these applications also require several ports to communicate through. Such applications do not work if NAT is active.

Using port forwarding (the forwarding of requests to particular ports) the router is forced to send requests from the Internet for a certain service, for example a game, to the appropriate port(s) on the PC on which the game is running. If you configure Port Forwarding, the SX682 WiMAX outwardly assumes the role of the server. It receives requests from remote users under its public IP address and automatically redirects them to local PCs. The private IP addresses of the servers on the local network remain protected.

Internet services are addressed via defined port numbers. The SX682 WiMAX needs a mapping table of the port numbers to redirect the service requests to the servers that actually provide the service. Port Forwarding has to be configured for this purpose.

- ▶ Open the **Advanced Settings** tab and on the **Internet** menu select **Port Forwarding**.
- ▶ Define the list of services for which you want requests from the Internet to be forwarded.

Important services are already included in the **Predefined applications** selection field. The list can hold up to 16 entries.



The IP addresses of the PCs for which you set up port forwarding must remain unchanged. If the IP addresses of the PCs are assigned via the DHCP server of the SX682 WiMAX, you must select the option **Never expires** as the **Lease time** when configuring the DHCP server or assign static IP addresses to the PCs, see "Configuring the DHCP server" on page 39.



This function is not available in **Bridge** operating mode, see "Configuring Internet access" on page 35.

Opening the firewall for a selected PC (Exposed Host)

You can set up a client in your local network to be a so-called "exposed host". Your device will then forward all incoming requests from the Internet to this client, with the exception of requests to the port numbers already defined via port forwarding. You can then, for example, operate your own Web server on one of the clients in your local network and make it accessible to Internet users.

As the exposed host, the local client is directly visible to the Internet and therefore particularly vulnerable to attacks (e.g. hacker attacks). Only activate this function if it is absolutely necessary (e.g. to operate a Web server) and other functions (e.g. port forwarding) are not adequate. In this case you should take appropriate measures for the clients concerned.

- ▶ Open the **Advanced Settings** tab and on the **Internet** menu select **Exposed Host**.
- ▶ Define the list of PCs you want to set up as exposed hosts.
- ▶ Activate a PC which you want to function as the current exposed host. Only one PC at a time can be selected.



The IP addresses of the PCs you want to set up as exposed hosts must remain unchanged. If the IP addresses of the PCs are assigned via the DHCP server of the SX682 WiMAX, you must select the option **Never expires** as the **Lease time** when configuring the DHCP server or assign static IP addresses to the PCs, see "Configuring the DHCP server" on page 39.



This function is not available in **Bridge** operating mode, see "Configuring Internet access" on page 35.

LAN configuration

With the help of the LAN configuration you can change the preset values for the computer name and the private IP address for your SX682 WiMAX and configure the integrated DHCP server.

- ▶ Open the **Advanced Settings** tab and select **Local Network**.

The preset IP address is 192.168.2.1. This is the private IP address of the SX682 WiMAX. This is the address under which the device can be reached in the local network. It can be freely assigned from the block of available addresses. The IP address under which the SX682 WiMAX can be reached from outside is assigned by the Internet service provider. The default Subnet mask for the local network administered by the SX682 WiMAX is 255.255.255.0.

Please note which subnet mask is set when assigning the IP address. The preset subnet mask defines the first three parts of the IP address which must be identical for all network components (including routers).

We recommend that you use an address from a block that is reserved for private use. This address block is 192.168.1.1 to 192.168.255.254.

Configuring the DHCP server

The SX682 WiMAX has a DHCP server for which the factory setting is active. Consequently, the IP addresses of the PCs are automatically assigned by the SX682 WiMAX.

i

◆ If the DHCP server for the SX682 WiMAX is activated, you can configure the network setting on the PC so that the option **Obtain an IP address automatically** is set up.

◆ If you deactivate the DHCP server, you will have to assign a static IP address for the PCs that use the network settings.

For more information see the document “Configuring the local area network” on the CD.

- ▶ If the DHCP server is active, you can define a **Lease time**. The lease time indicates how long the client may use the allocated IP configuration.

Note:

If you select **Never expires**, the IP addresses are never changed. Activate this option if you want to make NAT or firewall settings using the IP addresses of the PCs; otherwise you have to assign static IP addresses to these PCs.

- ▶ Define the range of IP addresses the SX682 WiMAX should use to automatically assign IP addresses to the PCs. Define the **Start IP** and the **End IP**.

Setting up Internet telephony (VoIP)

Assigning static IP addresses to individual PCs

Even if you have activated the DHCP server, you can still assign a static IP address to individual PCs (e.g. when setting up these PCs for NAT functions).

- ▶ Enter the **MAC address** of the PC to which you want to assign a static IP address and the **IP address** you wish to assign to the PC.

Configuring the local network in Bridge operating mode

In **Bridge** operating mode (→ page 35) the SX682 WiMAX DHCP server is deactivated. The network components get their IP addresses from a DHCP server in the public network.

Ageing time for MAC table When a PC in the network is accessed, your SX682 WiMAX writes the MAC address and port number in a MAC table to speed up further accesses. The entry in the MAC table is deleted after a fixed time. If necessary you can change this value via the **MAC table ageing time** parameter.

Protection against DoS attacks DoS (Denial of Service) attacks are attacks on a system in the network to make its services unusable. This is basically done by overloading the system by constantly sending requests. In Bridge mode, the SX682 WiMAX provides protection against DoS attacks, which you can enable or disable via the **activate DOS protection** parameter.

Setting up Internet telephony (VoIP)

The SX682 WiMAX allows you to make phone calls over the Internet with an analogue telephone. For Internet telephony (VoIP) you need the access authorisation of your provider and the corresponding access data.

You can connect an analogue telephone, a base for mobile components or a fax machine to the phone port of your SX682 WiMAX.

To be able to make phone calls over the Internet via VoIP, you will need to set up your VoIP account using the information supplied by your VoIP provider.

If you have executed the Basic Setup Wizard, you will already have entered these details there. If necessary you can change them here.



For PPPoE Internet connections, do **not** change the default setting for the Internet connection mode (= “Always on”) if you use VoIP (page 35). You can only receive calls via VoIP if this mode is set. Bear in mind, however, that this setting may incur high connection costs if you have a time-based tariff with your Internet provider.

You get the access and configuration data for Internet telephony from your provider.

- ▶ Open the **Advanced Settings** tab and select **Telephony**.

- ▶ Enter the access data for your VoIP account that you received from your VoIP provider. You can normally keep the default settings, unless your provider explicitly requires other values.

You can enable or disable the following options:

Comfort noise generation

In digital voice transmission, CNG (Comfort Noise Generation) ensures that the listener hears a slight background noise in the pauses between speech, otherwise they might think the connection has been lost.

Out-of-band DTMF

With analogue phones, DTMF (Dual-Tone Multi-Frequency, a multi-frequency dialling system) is used to dial a number or transmit digits during a connection. There are two kinds of DTMF:

Out-of-band: DTMF digits are transmitted in the voice-frequency band (above G.711).

In-band: DTMF digits are transmitted through RFC 2833 signalling (e.g. when retrieving an external voicemail).

Telephone functions

You can also configure the following telephone functions:

- Call waiting** An incoming call is signalled while you are on the phone (only for phones on the Phone port).
- Call forwarding** You can forward incoming calls to another telephone connection. There are the following possibilities:
- Forwarding always:** All calls are forwarded at once.
 - Forwarding on busy:** Calls are forwarded if your connection is busy.
 - Forwarding on no response:** Calls are forwarded if the phone is not answered.
- Call transfer** You can transfer calls to other participants if this feature is available also for the other participants.



Call waiting and **Forwarding on busy** cannot both be activated in parallel.



For detailed information on the telephone functions, see section "Making a phone call or faxing with the SX682 WiMAX" on page 51.

WiMAX configuration

On this page you enter the data for authentication of your device on the WiMAX base station. You will need the access data supplied by your WiMAX operator for this.

If you have executed the Basic Setup Wizard, you will already have entered these details there. If necessary you can change them here.

- ▶ Open the **Advanced Settings** tab and select **WiMAX configuration** from the menu.
- ▶ Select **Authentication**, if authentication is required by your WiMAX operator and enter or change the required access data.

Antenna selection

On this page you select the antenna to be used for your connection.

If you have executed the Basic Setup Wizard, you will already have entered these details there. If necessary you can change the setting here.

- ▶ Open the **Advanced Settings** tab and select **Antenna selection** from the menu.



To establish an optimum connection to the WiMAX base station, you may have to adjust the antenna. Go through the Basic Setup Wizard - it will help you with the exact adjustment of your antenna for optimum reception, see "Establishing a radio connection to a WiMAX network" on page 28.

Administration

The user interface **Administration** menu includes several helpful functions for administering your SX682 WiMAX.

System Password	Changes the system password (page 43)
Factory Reset	Reset the SX682 WiMAX to the factory settings (page 44)
Restart	Reboots the device (page 45)
Firmware Update	Updates firmware (page 45)



Depending on the pre-configuration of your device some of the menu entries and configuration possibilities might be missing in your device.

System password

The system password is the password for configuring your SX682 WiMAX and is requested when you open the configuration pages, see "Launching the user interface" on page 21.

If the device came from your provider with a preset system password, you can change this password here.



The system password protects your SX682 WiMAX and your local network from unauthorised access. For this reason, it is important to set up a password and change the default password.

- ▶ Open the **Advanced Settings** tab and on the **Administration** menu select **System Password**.

Features of a secure password

A password should be difficult for unauthorised users to work out. Note the following points when choosing a password:

- ◆ The more characters a password has, the more secure it is.
- ◆ Choose a series of characters that is as varied as possible (not AAAA, 0000) and alternate between letters and numbers.
- ◆ Do not use any term that could be found in a dictionary.
- ◆ Do not use sequential characters (not 123456, abcd) and no recognisable system (not 1a2b3c).
- ◆ Never use a password several times for different applications.
- ◆ Never save a password on the PC. Instead, make a note of it and store it in a secure place.
- ◆ Change your passwords regularly.

Restoring factory settings

Changing the password

- ▶ Enter the current password in the **Current password** field. If no default system password has been set, leave this field empty.
- ▶ Enter a new password in the **New password** field.
 - Select any series of characters with a minimum length of 4 and a maximum length of 20 characters. You can use the following characters: A–Z, a–z, 0–9 as well as the following special characters: \ ! " \$ % & ' / () = ? | + # * ~ , . - ; : _ ^ < > @ [] { }.
 - Note down your new password on a sheet of paper and store it in secure place.
- ▶ Enter your new password in the **Confirm new password** field again. This entry is case-sensitive.

The new password can only be activated if both entries match. This detects typing errors when the password is entered.
- ▶ Finally, click **Ok** to accept your change and to activate the new password.

The new password is valid immediately for each instance the configuration is called up.



The configuration of the SX682 WiMAX cannot be accessed if you do not enter a valid password. In this case, you must restore all the factory settings of the SX682 WiMAX. To find out how to do this, see chapter "Returning the SX682 WiMAX to factory settings" on page 20.

Restoring factory settings

You can reset the SX682 WiMAX to the factory settings. You should do this before making the device available to others or exchanging it through the dealer. Otherwise unauthorised users may use the Internet access data at your expense.

- ▶ Open the **Advanced Settings** tab and on the **Administration** menu select **Factory reset**.
- ▶ Click **Ok**.

A window will appear prompting you to confirm the procedure.



- ◆ Please remember that when the device is fully reset, **all** the configuration settings are returned to the factory settings. This means that you will have to completely reconfigure the SX682 WiMAX.
- ◆ You can also reset the SX682 WiMAX via the Reset button on the device itself (→ page 20).

Restart

If the SX682 WiMAX is not operating properly, you can reboot it. It should then be ready for use again.

- ▶ Open the **Advanced Settings** tab and on the **Administration** menu select **Restart**.
- ▶ Click **Ok** to reboot the device.

A window will appear prompting you to confirm the procedure.

Updating the firmware

If your WiMAX provider provides a new downloadable firmware version for your SX682 WiMAX with new functions or to fix errors, you can update your device quickly and easily.

- ▶ First download the relevant firmware file from the Internet and save it on your PC. Read the information provided carefully.



Only update the firmware if there is a new version of the firmware that is currently installed on your device on the Internet. The firmware version currently installed is shown under **Active image version**.

- ▶ Open the **Advanced Settings** tab and on the **Administration** menu select **Firmware Update**.
- ▶ Enter the path and file name of the firmware file to be installed or click **Browse** to select a file on your PC.
- ▶ Click **Ok** to start the firmware update.



Do not disconnect your SX682 WiMAX from the PC or the power supply during the firmware update, as this could damage the device. It may take up to five minutes before the device is ready for use again.

Status

You can check the status of your SX682 WiMAX with the pages in the **Status** menu. The menu is divided into several individual pages opened by clicking the entries in the menu area. To help with orientation, in the following sections the path is placed first so that you can quickly find the status messages described.

For example, with the following address you can open the settings of your LAN:

Status > Local Network.

i	<p>If you have problems, before contacting your provider or customer service, check the status of your SX682 WiMAX.</p> <p>When looking for the fault, your provider or customer service will need some details that you will find on the status pages.</p>
----------	---

You will find the most important status information summarised on the homepage. For detailed information, click an entry in the submenu.

Information on the Status homepage

- Connection status** The status of the radio connection with the WiMAX network is displayed as follows:
- ◆ **connected** = The SX682 WiMAX has established a radio connection with a WiMAX network. You will see the connection duration in brackets and in the format ddd:hh:mm:ss (d=days, h=hours, m=minutes, s=seconds).
 - ◆ **disconnected** = The SX682 WiMAX is trying to establish a connection with a WiMAX network.
- IP address** For an existing Internet connection only:
Displays the IP address used by the SX682 WiMAX on the Internet.
- IP address** IP address used by the SX682 WiMAX in your local network.
- DHCP server** Displays whether the DHCP server of your SX682 WiMAX is activated. As DHCP server, your SX682 WiMAX assigns an IP address to all the PCs in the network. DHCP must be activated on a PC for the PC to receive an IP address from the DHCP server. For more information see the document "Configuring the local area network" on the product CD.
- VoIP status** Shows whether Internet telephony is set up.
- System time** Displays the current date and time. The date and time are transmitted to your SX682 WiMAX from the WiMAX network.
- Operating mode** Role played by your SX682 WiMAX during connection setup to the Internet (**Router** or **Bridge**).
- Firmware version** Version number of the currently installed device software. You will also need to give your provider this number.

- ▶ If necessary, click the **Refresh** button to refresh the data in the status display.

Internet

Status > Internet

The connection settings for your SX682 WiMAX are displayed in the **Internet** sub-menu.

Connection status	The status of the radio connection with the WiMAX network is displayed as follows: <ul style="list-style-type: none"> ◆ connected = The SX682 WiMAX has established a radio connection with a WiMAX network. You will see the connection duration in brackets and in the format ddd:hh:mm:ss (d=days, h=hours, m=minutes, s=seconds). ◆ disconnected = The SX682 WiMAX is trying to establish a connection with a WiMAX network.
IP address	For an existing Internet connection only:
Subnet mask	Displays the public IP address and subnet mask via which your SX682 WiMAX establishes the connection with the Internet.
MAC address	The MAC address uniquely identifies a network component within a network, in this case the public MAC address of your SX682 WiMAX within the WiMAX network you use.
Default gateway	For an existing Internet connection only: Displays the gateway the SX682 WiMAX uses for connecting to the Internet.
DHCP server	IP address of the DHCP server with which the SX682 WiMAX is connected. While the SX682 WiMAX has not been assigned an IP address by the WiMAX network, the field stays empty.
Preferred DNS server	For an existing Internet connection only:
Alternate DNS server	Displays the domain name server the SX682 WiMAX uses to convert names to IP addresses.
Address Translation (NAT)	Displays whether NAT mode is activated on your SX682 WiMAX. NAT converts the internal IP addresses of the PCs in your network to public IP addresses. This maintains the confidentiality of your internal IP addresses.

- ▶ If necessary, click the **Refresh** button to refresh the data in the status display.

Local network LAN

Status > Local Network

The configuration of the local network is displayed in the **Local Network** submenu.

IP address	IP address used by the SX682 WiMAX in your local network. Default: 192.168.2.1
Subnet mask	Subnet mask of your local network. Default: 255.255.255.0
MAC address	The MAC address uniquely identifies a network component within a network, in this case the local MAC address of your SX682 WiMAX within your local network.
DHCP server	Displays whether the DHCP server of your SX682 WiMAX is activated. As DHCP server, your SX682 WiMAX assigns an IP address to all the PCs in the network. If the DHCP server is activated, you will see the network subscribers that have received your IP address from the DHCP server in the DHCP clients field. DHCP must be activated on a PC for the PC to receive an IP address from the DHCP server. For more information see the document "Configuring the local area network" on the product CD.

- ▶ If necessary, click the **Refresh** button to refresh the data in the status display.

Telephony

Status > Telephony

The VoIP configuration is displayed in the **Telephony** submenu.

User name	The user name registered with your VoIP provider.
SIP domain	The name of your VoIP provider's SIP domain.
Status	Current status of your analogue phone connection: You can see whether your SX682 WiMAX is registered to a server and whether there is currently an active connection.

- ▶ If necessary, click the **Refresh** button to refresh the data in the status display.

Device status

Status > Device Status

The device status of your SX682 WiMAX is displayed in the **Device Status** submenu.

System uptime	Operating time of your SX682 WiMAX since it was last restarted. The operating time is given in the format ddd:hh:mm:ss (d=days, h=hours, m=minutes, s=seconds).
System time	Displays the current date and time. This information is transmitted to your SX682 WiMAX by the WiMAX network.
Operating Mode	Role played by your SX682 WiMAX during connection setup to the Internet (Router or Bridge).
Device temperature	Current device temperature inside your SX682 WiMAX. In the event of overheating, the SX682 WiMAX switches off.
System Log	Error protocol in which you will find information about problems.

► If necessary, click the **Refresh** button to refresh the data in the status display.

Radio status

Status > Radio Status

Information about the radio connection to the WiMAX network is displayed in the **Radio Status** submenu.

Connected to a base station

Indicates whether or not your SX682 WiMAX is connected to a base station.

Base station ID

ID number of the base station to which the device is connected.

MAC state

Status of the connection setup to the base station. The information shown here is only intended for technically experienced users. Under **Connected to a base station** is shown whether a connection to a base station exists.

Authentication

Indicates whether an authentication method is used for the WiMAX connection.

Protocol

Protocol used for authentication.

Received power level

Receive level from the WiMAX base station. Values in the range -70 dBm to -10 dBm are considered optimum. You can ensure this by optimising the antenna direction.

Radio status

Transmitted power level

Current transmission power.

Carrier to interference and noise ratio

Measurement of the reception quality of the base station. The higher the value, the better the quality of the data transfer to the base station.

Centre frequency of current uplink channel

Currently used uplink frequency. The reading changes frequently during the measurement.

Centre frequency of current downlink channel

Currently used downlink frequency.

Current channel bandwidth

Currently used bandwidth.

Radio port uplink current average throughput

Average approximate uplink throughput in one second, moving average (5 samples).

Radio port downlink current average throughput

Average approximate downlink throughput in one second, moving average (5 samples).

Current uplink modulation scheme

Currently used uplink modulation type.

Current downlink modulation scheme

Currently used downlink modulation type.

- ▶ If necessary, click the ***Refresh*** button to refresh the data in the status display.

Using the SX682 WiMAX

When you have finished configuring your SX682 WiMAX, use it to surf the Internet, send e-mails or make phone calls via the Internet etc.

As soon as you attempt to access the Internet with a PC connected to the SX682 WiMAX (for example, by opening the Web browser and calling up an Internet site, or by starting your e-mail program and retrieving e-mails), your SX682 WiMAX automatically establishes a connection to the Internet or uses the permanent Internet connection. Whether the connection needs to be established or is permanently available depends on your provider's default settings.

Making a phone call or faxing with the SX682 WiMAX

You can use your SX682 WiMAX to make calls via the Internet (VoIP) and operate a fax machine or answer machine without installing any additional software. If you wish, for example, to make a phone call via the Internet, you do not need to switch on your PC.

In order to operate an analogue terminal on your SX682 WiMAX, the following preconditions must be satisfied:

- ◆ You have an analogue terminal (telephone, fax machine or answer machine) connected to your SX682 WiMAX.
- ◆ Internet telephony (VoIP) is included in your contract with your provider. This is necessary as your provider needs to set up VoIP access for you. You can find out whether VoIP access is configured in your SX682 WiMAX either from the documentation given to you by your provider or by referring to the relevant status page on your SX682 WiMAX; see Chapter "Telephony" on page 48.
- ◆ Your SX682 WiMAX will adjust extremely flexibly to your requirements: if you wish to make a call via VoIP, the SX682 WiMAX will automatically provide a permanent bandwidth for the purpose. This enables good voice quality when making a call via VoIP.
- ◆ You need a permanent Internet connection if you wish to be permanently accessible and make calls via VoIP.



Please note that you cannot make phone calls via the Internet in the event of a power failure.

Ask your provider which emergency numbers are available via the VoIP connection. It is also possible that service numbers cannot be reached in the usual way.

Ask your provider about VoIP rates for VoIP connections.

The VoIP features may vary considerably, depending on your provider's VoIP configuration. You should therefore read the documentation given to you by your provider and, where applicable, visit your provider's Internet site for further options.

Making a phone call or faxing with the SX682 WiMAX

Making calls via VoIP

Make telephone calls in the same way as on a conventional phone: dial as usual or use the directory to dial. The **Phone** LED flashes green.

Receiving VoIP phone calls

Your PC does not need to be switched on for you to receive calls. You only need the SX682 WiMAX to be ready for operation (**Phone** LED lights up green).

For you to receive calls via VoIP, let potential callers know your VoIP phone number. You will find your VoIP phone number in the documentation supplied by your provider.



As soon as a call comes in on your VoIP phone, the **Phone** LED starts to flash green and the phone rings. When you lift the receiver or press the connect button, your SX682 WiMAX will provide the appropriate bandwidth for voice transmission. If you are surfing the Internet at the same time, the data might be transmitted slightly more slowly, similar to when downloading several large data packets. The call is made in the same way as via a conventional phone line. When you have ended the call, the **Phone** LED glows green again and your SX682 WiMAX makes the entire bandwidth available for data transfer.

Telephone functions

This section describes the telephone functions available via the phone socket of your SX682 WiMAX.





Telephoning

You want to call someone.

Key sequence	Action
	▶ Lift the receiver.
	▶ Dial the number you want to call. The call is connected.
	▶ Hang up the receiver to end the call.

Consultation Call



You are on the phone to subscriber A. During the call you want to call subscriber B with an enquiry. When you finish talking to subscriber B, you want call A to be restored.

Key sequence	Action
	You are on the phone to subscriber A.
	▶ Press the R button. Subscriber A is put on hold. You hear the dialling tone for the second call.
	▶ Dial the number for subscriber B. The call is connected and you can talk to subscriber B.
	▶ Hang up the receiver to end the call. You will receive an automatic callback from subscriber A.
	▶ Pick up the receiver and resume the call to subscriber A.

If you cannot get through to subscriber B

Key sequence	Action
	If you cannot get through to subscriber B because the line is busy, you will hear the busy tone.

either

	▶ Hang up the receiver to end the call. You will receive an automatic callback from subscriber A.
	▶ Pick up the receiver and resume the call to subscriber A.



or

	▶ Press the R button. Your call to subscriber A will be reconnected.
---	---

Making a phone call or faxing with the SX682 WiMAX

Accepting a call waiting



You are on the phone to subscriber A. A call comes in from subscriber B. You want to accept the call from subscriber B and end the call to subscriber A.

Key sequence	Action
	You are on the phone to subscriber A.
	During the call you hear the “call waiting” tone.
	▶ Hang up the receiver to end the call to subscriber A.
	▶ Pick up the receiver again. You will be connected to subscriber B.

	A waiting call is only signalled on your phone if the Call waiting function is activated. You can make the desired settings via the configuration program (→ page 40).
---	---





Alternating between callers (call holding)

You are on the phone to subscriber A. A call comes in from subscriber B. You want to accept the call from subscriber B without ending the call to subscriber A.

Key sequence	Action
	You are on the phone to subscriber A.
	During the call you hear the “call waiting” tone.
	▶ Press the R button. Subscriber A is put on hold. You are connected to subscriber B.
	▶ Press the R button. Subscriber B is put on hold. You are reconnected to subscriber A.

Call transfer





You are on the phone to subscriber A and you want to transfer the call to subscriber B.

Key sequence	Action
	You are on the phone to subscriber A.
	▶ Press the R button. Subscriber A is put on hold.
	▶ Dial the number for subscriber B. The connection to subscriber B is established.
	▶ Hang up the receiver. Subscriber A and subscriber B are connected.

i	The Call transfer function must be activated via the configuration program (→ page 40) and must be available at the other subscribers.
----------	---

Conference calling

You want to make a conference call to two other parties.

Key sequence	Action
	▶ Pick up the receiver.
	▶ Dial the number for subscriber A. The call is connected. Subscriber A answers.
	▶ Press the R button. Subscriber A is put on hold. You hear the dialling tone for a second call.
	▶ Dial the number for subscriber B. The call is connected. Subscriber B answers.
	▶ Press the R button. The conference call between you, subscriber A and subscriber B is set up.

If you press the R button while the call is being connected to subscriber B, the call setup is cancelled and you continue with your call to subscriber A.

Making a phone call or faxing with the SX682 WiMAX

Ending a conference call

You want to end the call to subscriber B.

Key sequence	Action
	<p>▶ Press the R button.</p> <p>The connection to subscriber B is terminated and you continue with your call to subscriber A.</p>



You want to end the conference call with both parties.

Key sequence	Action
	<p>▶ Hang up the receiver.</p> <p>The conference call is terminated.</p>

Subscribers A and B can quit the conference call at any time by hanging up. The connection to the remaining subscriber continues.

Call transfer during conference

You have initialised a conference call with subscriber A and subscriber B and now you want to back out of the conference call. Subscriber A and Subscriber B should remain connected.

Key sequence	Action
	You are on the phone to subscriber A and subscriber B.
	<p>▶ Hang up the receiver.</p> <p>The conference is terminated for you. Subscriber A and subscriber B remain connected.</p>

	The Call transfer and Call transfer during conference functions must have been activated using the configuration program (→ page 40).
---	---

Call forwarding

You can forward incoming calls to another telephone extension always, on busy or on no response and define each with different destinations. The destinations for forwarding are set via the configuration program, see "Setting up Internet telephony (VoIP)" on page 40.

You activate or deactivate the desired function via the configuration program or directly on the phone.



The key sequences described below are default settings and may be different for your VoIP provider. Please use the appropriate information of your provider.

Key sequence	Action: Activating "Forwarding always"
* 2 0	<p>▶ Press the star key and then the keys 2 and 0.</p> <p>All incoming calls are forwarded to the phone number defined in the configuration program.</p> <p>When Forwarding always is active and an incoming call is forwarded, this is signalled by a splash ring (single ring).</p> <p>If Forwarding always is active and you pick up the phone to make an outgoing call 3 beep tones are played before the dialtone (Stutterdial Tone).</p>
	Action: Deactivating "Forwarding always"
* 2 1	<p>▶ Press the star key and then the keys 2 and 1.</p> <p>Call forwarding will be deactivated.</p>
	Action: Activating "Forwarding on busy"
* 3 0	<p>▶ Press the star key and then the keys 3 and 0.</p> <p>If your connection is busy, all incoming calls are forwarded to the phone number defined in the configuration program.</p> <p>Note: The <i>Forwarding on busy</i> and <i>Call waiting</i> functions cannot be activated both in parallel.</p>
	Action: Deactivating "Forwarding on busy"
* 3 1	<p>▶ Press the star key and then the keys 3 and 1.</p> <p>Call forwarding on busy will be deactivated.</p>
	Action: Activating "Forwarding on no response"
* 4 0	<p>▶ Press the star key and then the keys 4 and 0.</p> <p>If incoming calls are not answered, they are forwarded to the phone number defined in the configuration program.</p>

Confirmation tones

	Action: Deactivating "Forwarding on no response"
* 4 1	▶ Press the star key and then the keys 4 and 1. Call forwarding on no response will be deactivated.
	Action: Deactivating call forwarding in all cases
* 1 1	▶ Press the star key and then press twice the key 1. All call forwarding settings will be deactivated.

Confirmation tones

If you execute one of the actions listed in section "Call forwarding" on page 57 you will hear a confirmation tone. The confirmation tone sounds even if the action doesn't make sense, e.g. if you try to activate a feature that is already activated. After a confirmation tone you must hang up the receiver before you can execute another action or before you can telephone.

Confirmation tone: Call forwarding is activated and an incoming call is forwarded.
If you are at home this signal will remind you that call forwarding is activated.

Sutter-dial tone (short signal tone) Call forwarding is activated and you lift the receiver.

i	The confirmation tones can be configured by the operator.
----------	---

Appendix

Troubleshooting

Fault tracing

When troubleshooting, start by checking the LEDs on your SX682 WiMAX. Please answer the questions on the left-hand side and follow the arrows to the answers and solutions:

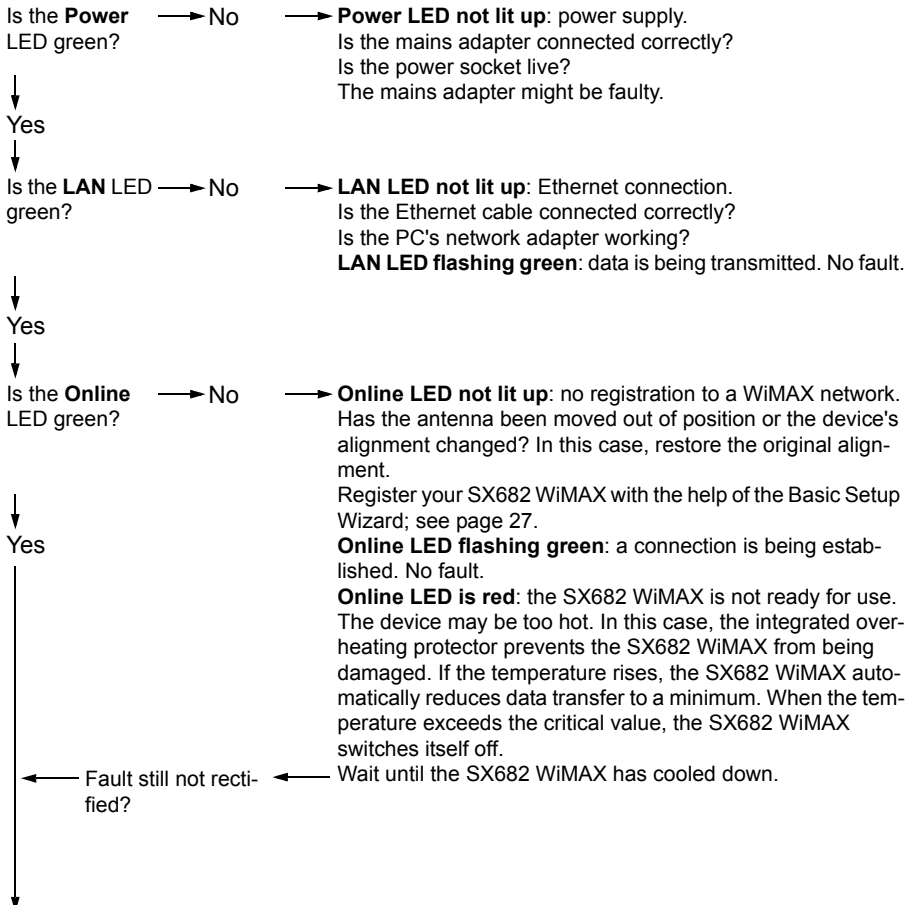

Troubleshooting

Can the configuration program be accessed? → Yes → Look for a suitable place to set up your SX682 WiMAX; see page 13.
Register your SX682 WiMAX with the help of the Basic Setup Wizard; see page 27.

↓
No

↓
Check the connection to your SX682 WiMAX; see page 62.

↓

Is there a connection? → Yes → The Web browser (Internet Explorer, Mozilla Firefox) is incorrectly configured; see page 63.

↓
No

↓
The TCP/IP network is incorrectly configured on the PC; see document "Configuring the local area network" on product CD.

Other faults and problems

You are using a firewall on the PC that prevents access to the SX682 WiMAX

Test this, if necessary, by briefly switching off the firewall. If access is possible, configure the firewall. For details, refer to the user guide for your firewall.

You have forgotten the system password

If you have assigned your own system password or changed and forgotten it, you need to return your SX682 WiMAX to the factory settings; see Chapter "Returning the SX682 WiMAX to factory settings" on page 20.

The Online LED is lit up permanently in red and the possibility of the device overheating can be excluded

The SX682 WiMAX may be faulty. Restart the SX682 WiMAX; see "Rebooting the SX682 WiMAX" on page 19. If the **Online** LED remains red after the device has been restarted and does not go off, please contact your provider/service technician.

Only a few LEDs have lit up to display the signal strength (RSSI) and the Online LED is green

If you are using the antenna integrated in the SX682 WiMAX, turn the SX682 WiMAX until more LEDs light up. Try to place the SX682 WiMAX even closer to the window and check the signal strength bar in the Basic Setup Wizard of the configuration program.

Power failure

No data will be lost.

Before contacting customer service or your provider

- ▶ First exclude all the faults listed in this section.
- ▶ Have the documentation supplied by your provider ready.
- ▶ If you can open the configuration program in the Web browser, click the **Status** tab.
- ▶ Note the number in the **Firmware version** field. This is the number of the currently installed device software.
- ▶ Open the **Local Network** submenu and note the entry consisting of numbers and letters in the **MAC address** field. The MAC address is used for the globally unique identification of your device.
- ▶ Leave the PC switched on and the configuration program open when you phone customer service or your provider. They might need still more information, which you will find on the status pages.

Checking the connection to the SX682 WiMAX

You can check whether the PC is correctly connected to the SX682 WiMAX. This can be done as follows:

- ▶ Open the command prompt on the PC:
 - Click **Start > Run**.
 - Enter `cmd` in the input field and click **OK**.
The **Command prompt** window opens.
- ▶ Check whether the SX682 WiMAX responds with the ping command. Enter `ping 192.168.2.1` and press Enter.

```
C:\>ping 192.168.2.1
```

The PC now sends some test packets via this connection and checks whether the connection partner responds. The connection partner may respond in the following ways:

- ◆ **Reply from the IP address of your SX682 WiMAX;** statistics about the connection are presented. If you receive these statistics, the connection to the device is OK.
- ◆ **The request exceeds the time limit;** it was not possible either to send or receive any packets. There is no physical connection between the PC and your SX682 WiMAX. Check the following points:

- Is the Ethernet cable between the SX682 WiMAX and the PC properly connected?

The **LAN** LED on the SX682 WiMAX must light up.

- Has TCP/IP been properly configured on your PC?

If the SX682 WiMAX has the IP address 192.168.2.1, your PC's IP address must be between 192.168.2.2 and 192.168.2.254. The subnet mask must be 255.255.255.0.

To find out the IP address of your PC, enter `ipconfig` in the command prompt.

```
C:\>ipconfig

Windows IP Configuration

Ethernet adapter Local Area Connection:

    Connection-specific DNS Suffix. . . : 
    IP Address. . . . . : 192.168.2.5
    Subnet Mask . . . . . : 255.255.255.0
    Default Gateway . . . . . : 192.168.2.1

C:\>_
```

If the SX682 WiMAX has not responded successfully to the `ping` command, you need to adjust the network settings on the PC. To find out how to do this, please read the document "Configuring the local area network" on the product CD.

If the SX682 WiMAX has responded successfully to the `ping` command, the network is configured correctly. If it is not possible to access the configuration program of your SX682 WiMAX, check and change the settings in your Web browser. To find out how to do this, please read the next chapter.

Configuring the Web browser

If you are using a current Web browser but cannot open the configuration program in it, check the Web browser settings.



We recommend Microsoft Internet Explorer Version 7.0 or Mozilla Firefox 3.0 as the Web browser.

- ◆ Do not use an HTTP proxy for accessing your SX682 WiMAX.
- ◆ Popup windows must be enabled for your SX682 WiMAX.

The following descriptions relate to Internet Explorer Version 7.0 and Mozilla Firefox Version 3.0.

Setting up an HTTP proxy

An HTTP proxy is a buffer for Internet pages that have been called up. For example, once called up, a page can continue to be shown even if you are currently offline. However, this buffer would prevent the configuration pages being read again when you call up the configuration for your SX682 WiMAX; for this reason, your SX682 WiMAX can only be configured if the HTTP proxy is not being used for local pages.

Check the HTTP proxy in the Web browser you wish to use for the configuration.

Internet Explorer 7.0:

- ▶ Open Internet Explorer.
- ▶ Click **Tools** and then **Internet Options**.
- ▶ Open the **Connections** tab.
- ▶ Click **LAN settings**.
- ▶ If the option **Use proxy server for LAN** is activated in the **Proxy server** area, activate the selection field **Circumvent proxy server for local addresses**. If the option **Use proxy server for LAN** is not activated, you do not need to make any settings.
- ▶ Click **OK** and then **OK** again to close the **Internet Options** window.

Firefox 3.0:

- ▶ Open Firefox.
- ▶ Click **Tools** and then **Settings**.
- ▶ Click **Advanced**.
- ▶ Open the **Network** tab and click **Settings** in the **Connection** area.
- ▶ Select either **No Proxy** or **Manual proxy configuration**. If you have chosen **Manual proxy configuration**, in the **No proxy for:** field, enter the IP block in which the IP address of your SX682 WiMAX is found:
192.168.2.0/24
- ▶ Click **OK** and then **OK** again to close the **Settings** window.

Allowing pop-up windows

Pop-up windows are small windows that are opened either as the result of an action or automatically. The device software for your SX682 WiMAX uses pop-up windows to display the online Help, for example.

Many Internet sites, however, call up distracting pop-up windows for effective advertisement placement, for example, without detracting from the layout of the site itself. To prevent these pop-up windows from opening, current Web browsers offer pop-up blockers.

If necessary, you can configure the pop-up blocker to display desirable pop-up windows and to block undesirable windows.



If you are using a different pop-up blocker, configure it to allow pop-up windows for the IP address 192.168.2.1.

Internet Explorer 7.0:

- ▶ Open Internet Explorer.
- ▶ Click **Tools** and then **Pop-up Blocker** and choose **Pop-up Blocker Settings**.
- ▶ Enter the IP address of your SX682 WiMAX as the Website address:
192.168.2.1
- ▶ Click the **Add** button.
- ▶ Click **Close** to apply the settings.

Firefox 3.0:

- ▶ Open Firefox.
- ▶ Click **Tools** and then **Settings**.
- ▶ Click **Content**.
- ▶ If the **Block pop-up windows** check box is activated, click **Exceptions** to its right.
- ▶ Enter the IP address of your SX682 WiMAX as the Website address:
192.168.2.1
- ▶ Click the **Allow** button.
- ▶ Click **Close** and **OK** to apply the settings.

Specifications

Model	SX682 WiMAX
Dimensions	Approx. 230 x 160 x 52 mm
Operating temperature	+5°C to +40°C
Network interface	1 Ethernet 10/100BaseT (RJ45) LAN connection (10BaseT Half Duplex, 10BaseT Full Duplex, 100BaseT Half Duplex or 100BaseT Full Duplex)
Telephone interface	1 FXS (RJ11) for connecting an analogue terminal (telephone, fax machine or answer machine)
Frequency	2.3–2.4 / 2.5–2.7 / 3.4–3.6 GHz
Output power	Max. 26 dBm
Power consumption	3–6 W, depending on operating state
Bandwidth	Optional 3.5 / 5.0 / 7.0 / 8.75 or 10.0 MHz
Type of transmission	TDD
Modulation technique	SOFDMA 512/1024
Subcarrier modulation	QPSK, 16/64 QAM
Encoding rate	1/2, 2/3, 3/4, 5/6
Antenna socket	50 Ohm reverse SMA
Antenna type	2 internal antennas (2xRX, 1xTX) for MIMO Matrix A & B; Type DN1 (EN 302 326-3 V1.2.2) Optional: outdoor antenna
Antenna gain	2.5 GHz: max. 7dBi, 3.5 GHz: max. 10 dBi (integrated antennas)
Antenna polarisation	Send direction vertical, Receive direction vertical and horizontal / vertical and vertical
Mains adapter	Input: 100–240 V AC Output: 12 V; 1.0 A DC

Outdoor antenna specifications (optional)

Model	Outdoor antenna
Operating temperature	–40 °C to +70 °C
Frequency	2.5–2.7 GHz or 3.4–3.6 GHz
Antenna socket	50 Ohm
Antenna gain	3.5 GHz: 18 dBi 2.6 GHz: 15 dBi
Antenna polarisation	Vertical or horizontal

Putting into service

This device is intended for use in the country indicated on the device's label.

The device is operated under a single licence, which is held by your service provider.

Contact your service provider regarding licensing before you put the device into service.

Please observe the legal provisions and local restrictions when putting the device into service. Please ask your service provider for further information.

CE declaration

This device is intended for use with WiMAX base stations.

We, Sagemcom Broadband SAS, declare that this device meets the essential requirements and other relevant regulations laid down in Directive 1999/5/EC.

National laws and regulations must be considered before putting the device into service.

A copy of the 1999/5/EC declaration of conformity is available at this Internet address: <http://support.sagemcom.com/>



Open Source Software used in the product

The SX682 WiMAX contains, among other things, Open Source Software, licensed under an Open Source Software License and developed by third parties. These Open Source Software files are protected by copyright. Your rights to use the Open Source Software beyond the mere execution of the Sagemcom Broadband SAS program, is governed by the relevant Open Source Software license conditions.

Your compliance with those license conditions will entitle you to use the Open Source Software as foreseen in the relevant license. In the event of conflicts between Sagemcom Broadband SAS license conditions and the Open Source Software license conditions, the Open Source Software conditions shall prevail with respect to the Open Source Software portions of the software. The Open Source Software is licensed royalty-free (i.e., no fees are charged for exercising the licensed rights, whereas fees may be charged for reimbursement of costs incurred by Sagemcom Broadband SAS). The license conditions can be found in the following chapters. In addition some of the license texts can also be downloaded from:

- ◆ The BSD License is available on the Internet at:
<http://www.freebsd.org/copyright/license.html>
- ◆ The OpenSSL license is available on the Internet at:
<http://www.openssl.org/source/license.html>
- ◆ The zlib license is available on the Internet at:
http://www.zlib.net/zlib_license.html
- ◆ Boost Software License
http://www.boost.org/LICENSE_1_0.txt

Warranty regarding further use of the Open Source Software

Sagemcom Broadband SAS provides no warranty for the Open Source Software programs contained in this device, if such programs are used in any manner other than the program execution intended by Sagemcom Broadband SAS. The licenses listed below define the warranty, if any, from the authors or licensors of the Open Source Software. Sagemcom Broadband SAS specifically disclaims any warranties for defects caused by altering any Open Source Software program or the product's configuration. You have no warranty claims against Sagemcom Broadband SAS in the event that the Open Source Software infringes the intellectual property rights of a third party.

Open Source Software used in the product

Open Source Software used

Open Source Software Component	License
wpa_supplicant	BSD-license
djbdns	public domain
zlib	Zlib license
boost lib	Boost Software License
expat	expat license
openssl	OpenSSL License, SSLeay License
sybyx	proprietary
AES and combined encryption / authentication modes	proprietary

Acknowledgements

WPA Supplicant:

Copyright (c) 2003-2007, Jouni Malinen <j@w1.fi> and contributors
All Rights Reserved.

OpenSSL:

This product includes software developed by the OpenSSL Project for use in the OpenSSL Toolkit. (<http://www.openssl.org/>)

This product includes cryptographic software written by Eric Young (eay@cryptsoft.com)

Zlib:

This product includes software developed by Jean-loup Gailly and Mark Adler

sybyx:

This product uses Streaming WBXML Parser developed by MediaSite Inc Research and Development Group.

Open Source Software Licenses

WPA-Supplicant

License: BSD

WPA Supplicant

=====

Copyright (c) 2003-2007, Jouni Malinen <j@w1.fi> and contributors
All Rights Reserved.

Redistribution and use in source and binary forms, with or without modification, are permitted provided that the following conditions are met:

1. Redistributions of source code must retain the above copyright notice, this list of conditions and the following disclaimer.
2. Redistributions in binary form must reproduce the above copyright notice, this list of conditions and the following disclaimer in the documentation and/or other materials provided with the distribution.
3. Neither the name(s) of the above-listed copyright holder(s) nor the names of its contributors may be used to endorse or promote products derived from this software without specific prior written permission.

THIS SOFTWARE IS PROVIDED BY THE COPYRIGHT HOLDERS AND CONTRIBUTORS "AS IS" AND ANY EXPRESS OR IMPLIED WARRANTIES, INCLUDING, BUT NOT LIMITED TO, THE IMPLIED WARRANTIES OF MERCHANTABILITY AND FITNESS FOR A PARTICULAR PURPOSE ARE DISCLAIMED. IN NO EVENT SHALL THE COPYRIGHT OWNER OR CONTRIBUTORS BE LIABLE FOR ANY DIRECT, INDIRECT, INCIDENTAL, SPECIAL, EXEMPLARY, OR CONSEQUENTIAL DAMAGES (INCLUDING, BUT NOT LIMITED TO, PROCUREMENT OF SUBSTITUTE GOODS OR SERVICES; LOSS OF USE, DATA, OR PROFITS; OR BUSINESS INTERRUPTION) HOWEVER CAUSED AND ON ANY THEORY OF LIABILITY, WHETHER IN CONTRACT, STRICT LIABILITY, OR TORT (INCLUDING NEGLIGENCE OR OTHERWISE) ARISING IN ANY WAY OUT OF THE USE OF THIS SOFTWARE, EVEN IF ADVISED OF THE POSSIBILITY OF SUCH DAMAGE.

OpenSSL

This is a copy of the current LICENSE file inside the CVS repository.

LICENSE ISSUES

The OpenSSL toolkit stays under a dual license, i.e. both the conditions of the OpenSSL License and the original SSLeay license apply to the toolkit.

See below for the actual license texts. Actually both licenses are BSD-style Open Source licenses. In case of any license issues related to openssl please contact openssl-core@openssl.org.

Open Source Software used in the product

OpenSSL License

Copyright (c) 1998-2005 The OpenSSL Project. All rights reserved.

Redistribution and use in source and binary forms, with or without modification, are permitted provided that the following conditions are met:

1. Redistributions of source code must retain the above copyright notice, this list of conditions and the following disclaimer.
2. Redistributions in binary form must reproduce the above copyright notice, this list of conditions and the following disclaimer in the documentation and/or other materials provided with the distribution.
3. All advertising materials mentioning features or use of this software must display the following acknowledgment: "This product includes software developed by the OpenSSL Project for use in the OpenSSL Toolkit. (<http://www.openssl.org/>)"
4. The names "OpenSSL Toolkit" and "OpenSSL Project" must not be used to endorse or promote products derived from this software without prior written permission. For written permission, please contact openssl-core@openssl.org.
5. Products derived from this software may not be called "OpenSSL" nor may "OpenSSL" appear in their names without prior written permission of the OpenSSL Project.
6. Redistributions of any form whatsoever must retain the following acknowledgment:
This product includes software developed by the OpenSSL Project for use in the OpenSSL Toolkit (<http://www.openssl.org/>)

THIS SOFTWARE IS PROVIDED BY THE OpenSSL PROJECT "AS IS" AND ANY EXPRESSED OR IMPLIED WARRANTIES, INCLUDING, BUT NOT LIMITED TO, THE IMPLIED WARRANTIES OF MERCHANTABILITY AND FITNESS FOR A PARTICULAR PURPOSE ARE DISCLAIMED. IN NO EVENT SHALL THE OpenSSL PROJECT OR ITS CONTRIBUTORS BE LIABLE FOR ANY DIRECT, INDIRECT, INCIDENTAL, SPECIAL, EXEMPLARY, OR CONSEQUENTIAL DAMAGES (INCLUDING, BUT NOT LIMITED TO, PROCUREMENT OF SUBSTITUTE GOODS OR SERVICES; LOSS OF USE, DATA, OR PROFITS; OR BUSINESS INTERRUPTION) HOWEVER CAUSED AND ON ANY THEORY OF LIABILITY, WHETHER IN CONTRACT, STRICT LIABILITY, OR TORT (INCLUDING NEGLIGENCE OR OTHERWISE) ARISING IN ANY WAY OUT OF THE USE OF THIS SOFTWARE, EVEN IF ADVISED OF THE POSSIBILITY OF SUCH DAMAGE.

=====

This product includes cryptographic software written by Eric Young (eyay@cryptsoft.com). This product includes software written by Tim Hudson (tjh@cryptsoft.com).

Original SSLeay License

Copyright (C) 1995-1998 Eric Young (eyay@cryptsoft.com)

All rights reserved.

This package is an SSL implementation written by Eric Young (eyay@cryptsoft.com). The implementation was written so as to conform with Netscapes SSL.

This library is free for commercial and non-commercial use as long as the following conditions are adhered to. The following conditions apply to all code found in this distribution, be it the RC4, RSA, lhash, DES, etc., code; not just the SSL code. The SSL documentation included with this distribution is covered by the same copyright terms except that the holder is Tim Hudson (tjh@cryptsoft.com).

Copyright remains Eric Young's, and as such any Copyright notices in the code are not to be removed. If this package is used in a product, Eric Young should be given attribution as the author of the parts of the library used. This can be in the form of a textual message at program startup or in documentation (online or textual) provided with the package.

Redistribution and use in source and binary forms, with or without modification, are permitted provided that the following conditions are met:

1. Redistributions of source code must retain the copyright notice, this list of conditions and the following disclaimer.
2. Redistributions in binary form must reproduce the above copyright notice, this list of conditions and the following disclaimer in the documentation and/or other materials provided with the distribution.
3. All advertising materials mentioning features or use of this software must display the following acknowledgement: "This product includes cryptographic software written by Eric Young (eay@cryptsoft.com)" The word 'cryptographic' can be left out if the routines from the library being used are not cryptographic related :-).
4. If you include any Windows specific code (or a derivative thereof) from the apps directory (application code) you must include an acknowledgement: "This product includes software written by Tim Hudson (tjh@cryptsoft.com)"

THIS SOFTWARE IS PROVIDED BY ERIC YOUNG "AS IS" AND ANY EXPRESS OR IMPLIED WARRANTIES, INCLUDING, BUT NOT LIMITED TO, THE IMPLIED WARRANTIES OF MERCHANTABILITY AND FITNESS FOR A PARTICULAR PURPOSE ARE DISCLAIMED. IN NO EVENT SHALL THE AUTHOR OR CONTRIBUTORS BE LIABLE FOR ANY DIRECT, INDIRECT, INCIDENTAL, SPECIAL, EXEMPLARY, OR CONSEQUENTIAL DAMAGES (INCLUDING, BUT NOT LIMITED TO, PROCUREMENT OF SUBSTITUTE GOODS OR SERVICES; LOSS OF USE, DATA, OR PROFITS; OR BUSINESS INTERRUPTION) HOWEVER CAUSED AND ON ANY THEORY OF LIABILITY, WHETHER IN CONTRACT, STRICT LIABILITY, OR TORT (INCLUDING NEGLIGENCE OR OTHERWISE) ARISING IN ANY WAY OUT OF THE USE OF THIS SOFTWARE, EVEN IF ADVISED OF THE POSSIBILITY OF SUCH DAMAGE.

The licence and distribution terms for any publicly available version or derivative of this code cannot be changed. i.e. this code cannot simply be copied and put under another distribution licence [including the GNU Public Licence.]

Zlib:

'zlib' general purpose compression library version 1.1.4, March 11th, 2002

Copyright (C) 1995-2002 Jean-loup Gailly and Mark Adler

This software is provided 'as-is', without any express or implied warranty. In no event will the authors be held liable for any damages arising from the use of this software.

Open Source Software used in the product

Permission is granted to anyone to use this software for any purpose, including commercial applications, and to alter it and redistribute it freely, subject to the following restrictions:

1. The origin of this software must not be misrepresented ; you must not claim that you wrote the original software. If you use this software in a product, an acknowledgment in the product documentation would be appreciated but is not required.
2. Altered source versions must be plainly marked as such, and must not be misrepresented as being the original software.
3. This notice may not be removed or altered from any source distribution.

Jean-loup Gailly
jloup@gzip.org

Mark Adler
madler@alumni.caltech.edu

The data format used by the zlib library is described by RFCs (Request for Comments) 1950 to 1952 in the files <ftp://ds.internic.net/rfc/rfc1950.txt> (zlib format), [rfc1951.txt](ftp://ds.internic.net/rfc/rfc1951.txt) (deflate format) and [rfc1952.txt](ftp://ds.internic.net/rfc/rfc1952.txt) (gzip format).

This manual is converted from `zlib.h` by piaip

Visit <http://ftp.cdrom.com/pub/infozip/zlib/> for the official zlib web page.

Boost lib

Boost Software License - Version 1.0 - August 17th, 2003

Permission is hereby granted, free of charge, to any person or organization obtaining a copy of the software and accompanying documentation covered by this license (the "Software") to use, reproduce, display, distribute, execute, and transmit the Software, and to prepare derivative works of the Software, and to permit third-parties to whom the Software is furnished to do so, all subject to the following:

The copyright notices in the Software and this entire statement, including the above license grant, this restriction and the following disclaimer, must be included in all copies of the Software, in whole or in part, and all derivative works of the Software, unless such copies or derivative works are solely in the form of machine-executable object code generated by a source language processor.

THE SOFTWARE IS PROVIDED "AS IS", WITHOUT WARRANTY OF ANY KIND, EXPRESS OR IMPLIED, INCLUDING BUT NOT LIMITED TO THE WARRANTIES OF MERCHANTABILITY, FITNESS FOR A PARTICULAR PURPOSE, TITLE AND NON-INFRINGEMENT. IN NO EVENT SHALL THE COPYRIGHT HOLDERS OR ANYONE DISTRIBUTING THE SOFTWARE BE LIABLE FOR ANY DAMAGES OR OTHER LIABILITY, WHETHER IN CONTRACT, TORT OR OTHERWISE, ARISING FROM, OUT OF OR IN CONNECTION WITH THE SOFTWARE OR THE USE OR OTHER DEALINGS IN THE SOFTWARE.

expat

Copyright (c) 1998, 1999, 2000 Thai Open Source Software Center Ltd and Clark Cooper

Copyright (c) 2001, 2002, 2003, 2004, 2005, 2006 Expat maintainers.

Permission is hereby granted, free of charge, to any person obtaining a copy of this software and associated documentation files (the "Software"), to deal in the Software without restriction, including without limitation the rights to use, copy, modify, merge, publish, distribute, sublicense, and/or sell copies of the Software, and to permit persons to whom the Software is furnished to do so, subject to the following conditions:

The above copyright notice and this permission notice shall be included in all copies or substantial portions of the Software.

THE SOFTWARE IS PROVIDED "AS IS", WITHOUT WARRANTY OF ANY KIND, EXPRESS OR IMPLIED, INCLUDING BUT NOT LIMITED TO THE WARRANTIES OF MERCHANTABILITY, FITNESS FOR A PARTICULAR PURPOSE AND NONINFRINGEMENT. IN NO EVENT SHALL THE AUTHORS OR COPYRIGHT HOLDERS BE LIABLE FOR ANY CLAIM, DAMAGES OR OTHER LIABILITY, WHETHER IN AN ACTION OF CONTRACT, TORT OR OTHERWISE, ARISING FROM, OUT OF OR IN CONNECTION WITH THE SOFTWARE OR THE USE OR OTHER DEALINGS IN THE SOFTWARE.

sybyx

<http://sourceforge.net/projects/sybyx/>

Copyright (c) 2001 MediaSite Inc Research and Development Group.

All rights reserved.

Copyright (c) 2002 Interactive Intelligence, Inc.

All rights reserved.

Redistribution and use in source and binary forms, with or without modification, are permitted provided that the following conditions are met:

1. Redistributions of source code must retain the above copyright notice, this list of conditions and the following disclaimer.
2. Redistributions in binary form must reproduce the above copyright notice, this list of conditions and the following disclaimer in the documentation and/or other materials provided with the distribution.
3. The end-user documentation included with the redistribution, if any, must include the following acknowledgment:
"This product uses Streaming WBXML Parser Developed by MediaSite Inc Research and Development Group"
Alternately, this acknowledgment may appear in the software itself, if and wherever such third-party acknowledgments normally appear.

THIS SOFTWARE IS PROVIDED "AS IS" AND ANY EXPRESSED OR IMPLIED WARRANTIES, INCLUDING, BUT NOT LIMITED TO, THE IMPLIED WARRANTIES OF MERCHANTABILITY AND FITNESS FOR A PARTICULAR PURPOSE ARE DISCLAIMED. IN NO EVENT SHALL MEDIASITE INC OR ITS CONTRIBUTORS BE LIABLE FOR ANY DIRECT, INDIRECT, INCIDENTAL, SPECIAL, EXEMPLARY, OR

Open Source Software used in the product

CONSEQUENTIAL DAMAGES (INCLUDING, BUT NOT LIMITED TO, PROCUREMENT OF SUBSTITUTE GOODS OR SERVICES; LOSS OF USE, DATA, OR PROFITS; OR BUSINESS INTERRUPTION) HOWEVER CAUSED AND ON ANY THEORY OF LIABILITY, WHETHER IN CONTRACT, STRICT LIABILITY, OR TORT (INCLUDING NEGLIGENCE OR OTHERWISE) ARISING IN ANY WAY OUT OF THE USE OF THIS SOFTWARE, EVEN IF ADVISED OF THE POSSIBILITY OF SUCH DAMAGE.
=====

Created by: Dima Skvortsov

Modified by: Chris Hubbard

AES and Combined Encryption/Authentication Modes

(<http://gladman.plushost.co.uk/oldsite/AES/index.php>)

<http://gladman.plushost.co.uk/oldsite/AES/aes-src-29-04-09.zip>

<http://gladman.plushost.co.uk/oldsite/AES/aes-modes-src-23-07-09.zip>

Copyright (c) 1998-2008, Brian Gladman, Worcester, UK. All rights reserved.

LICENSE TERMS

The redistribution and use of this software (with or without changes) is allowed without the payment of fees or royalties provided that:

1. source code distributions include the above copyright notice, this list of conditions and the following disclaimer;
2. binary distributions include the above copyright notice, this list of conditions and the following disclaimer in their documentation;
3. the name of the copyright holder is not used to endorse products built using this software without specific written permission.

DISCLAIMER

This software is provided 'as is' with no explicit or implied warranties in respect of its properties, including, but not limited to, correctness and/or fitness for purpose.

Issue Date: 21/07/2009

Glossary

Address Translation (NAT)

Network Address Translation. NAT is a method for converting IP addresses (mainly private IP addresses) in a network to one or more public IP addresses on the Internet. With NAT, several network components in a LAN can share a public IP address to connect to the Internet. The network components of the local network are hidden behind the IP address registered on the Internet. NAT is often used as part of the firewall in a network because of this security function.

Bridge

A bridge connects several network segments to form a joint network, e.g. to make a [TCP/IP](#) network. The segments can have different physical characteristics, e.g. different linking such as Ethernet and wireless LANs. Local networks can be expanded by linking individual segments via bridges.

dB

Decibel (a tenth of a Bel). Logarithmic unit of measurement for ratios between two currents, voltages, sound levels or powers. In order to depict large value differences clearly and graphically, these are given in dB; e.g. 60 dB corresponds to the factor 1000 relative to the voltage drops.

dBm

Decibel milliwatt. Power level in decibels relative to 1 milliwatt.

DHCP

Dynamic Host Configuration Protocol. DHCP handles the automatic assignment of IP addresses to network components.

DHCP was developed because in large networks – especially the Internet – the defining of IP addresses is very complex as subscribers frequently move, drop out or new ones join. A [DHCP server](#) automatically assigns the connected network components (DHCP clients) dynamic IP addresses from a defined IP pool range, thus saving a great deal of configuration work. In addition, the address blocks can be used more effectively: since not all subscribers are on the network at the same time, the same [IP address](#) can be assigned to different network components in succession as and when required.

DHCP server

There is a DHCP integrated into the SX682 WiMAX that automatically assigns IP addresses to PCs in the local network.

Glossary

DNS

Domain Name System. DNS permits the assignment of IP addresses to PC or domain names that are easier to remember. A DNS server must administer this information for each local network with an Internet connection. As soon as a page on the Internet is called up, the Web browser obtains the corresponding IP address from the DNS server so that it can establish the connection.

On the Internet, the assignment of domain names to IP addresses follows a hierarchical system. A local PC only knows the address of the local name server. This in turn knows all the addresses of the PCs in the local network and the superordinated name servers, which again know addresses and the next superordinated name servers.

Domain name

The domain name is the reference to one or more web servers on the Internet. The domain name is mapped via the [DNS](#) service to the corresponding IP address.

Downlink

Files that your SX682 WiMAX receives and forwards to your local network.

DSL

Digital Subscriber Line. DSL is a technique whereby data is transmitted via the conventional phone line. To do this, you require suitable phone lines and special technology to be set up by a [Provider](#). As these preconditions are not satisfied in all areas, it is not possible to use DSL in all locations. In order to make use of high-performance Internet access in these areas as well, technologies such as WiMAX, Wi-Fi or satellite connections are implemented.

Ethernet

Ethernet is a network technology for local networks (LANs) defined by the [IEEE](#) as standard IEEE 802.3. Depending on the network adapter used, the transmission speed on the Ethernet varies between 10 [Mbps](#) and 1 Gbps.

Firewall

Firewalls are used by network operators as protection against unauthorised external access. This involves a whole bundle of hardware and software actions and technologies that monitor and control the data flow between the private network to be protected and an unprotected network such as the Internet.

Firmware

Device software. To correct errors or update the device, a new firmware version can be loaded onto the device's memory (firmware update).

Flat rate

Flat rate is a particular billing system for Internet connections. The [Provider](#) charges a set monthly fee for a certain service package.

FTP

File Transfer Protocol. Protocol for exchanging files via the Internet. FTP is used, for example, to make files available for download or to receive files from other users.

Full duplex

Data transmission operating mode in which data can be sent and received at the same time.

FXS

Foreign Exchange Station. Phone port to which an analogue terminal (phone, fax or answer machine) can be connected.

Gateway

A gateway connects networks with one another. In contrast to a [Router](#), a gateway is not dependent on protocol, i.e. it is also able to establish connections between networks with a different architecture (protocols, application interfaces etc.).

Half duplex

Operating mode for data transfer. Only one party can receive or send data at a time.

HTTP

Hypertext Transfer Protocol. Network protocol for the transmission of data, which is mainly used for transmitting and displaying Internet content.

HTTP proxy

An [HTTP](#) proxy is a server that network components use for their Internet traffic. All requests are sent via the proxy.

Hub

A hub is a central distribution point in a network, to which PCs and other network devices are connected. The hub forwards received data to all connected PCs. For this reason, in large networks, a [Switch](#) is recommended to ensure that data is only sent to the PC requesting it.

IEEE

Institute of Electrical and Electronics Engineers. The IEEE is an international body for defining network standards, especially for standardising [LAN](#) technologies, transmission protocols and speeds, and wiring.

Glossary

IEEE 802.16

Standard defined by the [IEEE](#) for WiMAX. Similarly to other standards in the 802 series (e.g. 802.3 [Ethernet](#), 802.11 WLAN), the WiMAX standard is one of the standards for networks. The standard has progressed in accordance with new developments; there are currently two main versions:

- ◆ IEEE 802.16-2004: WiMAX, which specifies the secure location for connection partners.
- ◆ IEEE 802.16e-2005: Mobile WiMAX, which enables wireless cells to be exchanged during data transmission.

Internet telephony (VoIP)

Voice transmission via the Internet (Voice over IP).

IP

Internet Protocol. The protocol is responsible for addressing of subscribers in a network using IP addresses, and routes data from the sender to the recipient. In doing so, it decides on the way in which data packets will be forwarded between sender and recipient.

IP address

An IP address is the unique network-wide address of a network component in a network based on the [TCP/IP](#) protocol (e.g. in a local network or on the Internet). The IP address consists of four parts (each of up to three-figure strings of digits from 0–255) that are separated from one another by full stops (e.g. 192.168.2.1). The IP address is made up of the network number and the number of the network component. Depending on the [Subnet mask](#), one, two or three parts form the network number, the remainder form the network component number. You can find out the IP address of your PC using the `ipconfig` command.

There are two different types of IP address:

- ◆ **Private IP address:**
IP address of a network component within a local network.
- ◆ **Public IP address:**
IP address that uses a network component for accessing the Internet.

IP addresses can be assigned manually or automatically:

- ◆ **Static IP address:**
The IP address is manually assigned to a network component and never changes.
- ◆ **Dynamic IP address:**
The IP address is assigned to the network component by a DHCP server. The IP address of this network component can change each time it registers with a network or at specific time intervals.

On the Internet, domain names are normally used instead of the IP addresses. DNS is used to assign domain names to IP addresses.

IPTV

Internet **P**rotocol **T**ele**V**ision. You receive your provider's television service via the DSL connection. To do this, you require an IPTV-capable set-top box and the configuration data of your IPTV provider.

ISP

Internet **S**ervice **P**rovider. See [Provider](#).

LAN

Local **A**rea **N**etwork, local network. A local network links network components so that they can exchange data and share resources. The physical range is restricted to a particular area (a site). A local network can be connected to other local networks or a wide-area network (WAN) such as the Internet.

LED

Light **E**mitting **D**iode. An LED is an electronic component (semi-conductor) that generates light at low power consumption. LEDs are often used as signal lights for display and UI elements.

Login

Access to a PC or a service, password e.g. for access to the Internet.

MAC address

Media **A**ccess **C**ontrol. The MAC address is used for the globally unique identification of a network adapter. It comprises six parts (hexadecimal numbers), e.g. 00-90-96-34-00-1A. The MAC address is assigned by the network adapter manufacturer and cannot be changed.

Mbps

Million **b**its **p**er **s**econd. Specification of the transmission speed in a network.

Network

A network is a group of devices connected in wired or wireless mode so that they can share resources such as data and peripherals. A general distinction is made between local networks (LANs) and wide-area networks (WANs).

Network adapter

The network adapter is the hardware device that creates the connection between a network component and a local network. The connection can be wired or wireless. An Ethernet network card is an example of a wired network adapter. A network adapter has a unique address, the [MAC address](#).

Glossary

Network protocol

The network protocol is the standard via which different PCs exchange data in a network. A connection can only be established between PCs in a network if they all use the same protocol. The [TCP/IP](#) network protocol is the most extensive network protocol, which is also used for connections to the Internet. This must be set up on each PC from which a network connection is to be established.

Port

Data is exchanged between two applications in a network across a port. The port number addresses an application within a network component. The combination of [IP address](#)/port number uniquely identifies the recipient or sender of a data packet within a network. Some applications (e.g. Internet services such as HTTP or FTP) work with fixed port numbers; others are allocated a free port number whenever they need one.

Port forwarding

In port forwarding, the SX682 WiMAX directs data packets from the Internet that are addressed to a particular [Port](#) to the corresponding port of the appropriate network component. This enables servers within the local network to offer services on the Internet without them needing a public IP address. See also: [Virtual server](#)

Protocol

A protocol describes the agreements for communicating on a network. It contains rules for opening, administering and closing a connection, as well as about data formats, time frames and handling possible errors. Communications between two applications require different protocols at various levels, e.g. the [TCP/IP](#) protocols for the Internet.

Provider

A provider (Internet Service Provider) offers access to the Internet for a fee.

QoS

Quality of Service. QoS allows network traffic to be sorted according to priorities. This makes it possible to grant [Internet telephony \(VoIP\)](#) priority over other data traffic. This is a precondition for problem-free calls.

RJ

Registered Jack. Standardised connection, also known as a modular jack.

Router

A router directs data packets from one local area network ([LAN](#)) to another via the fastest route. A router enables the connection between networks of different network technologies and this is performed on the basis of a common protocol. For example, it can link a local network with WiMAX technology to the Internet.

RSSI

Received Signal Strength Indication. Characteristic value for the signal strength of radio connections, used by communication devices for the automatic selection of a suitable channel.

Server

A server makes services available to other network components (clients). The term "server" is often used to refer to a PC. However it can also mean an application that provides a particular service such as [DNS](#), [DHCP](#) or a Web service.

SIP

Session Initiation Protocol. SIP is a standard for data transfer in Internet telephony (VoIP). It describes how a call is carried over the data network and which components, which transport and signalling protocols are involved.

SMTP

Simple Mail Transfer Protocol. The SMTP protocol is a [TCP/IP](#) protocol and regulates the exchange of electronic post on the Internet. Your [Provider](#) provides you with access to an SMTP server.

Subnet

A subnet divides a network into smaller units.

Subnet mask

The subnet mask determines how many parts of the IP addresses of a network represent the network number and how many parts represent the network component number.

If the subnet mask in a network is 255.255.255.0, for example, this means that the first three parts of the [IP address](#) make up the network number and only the last part can be used to assign network component numbers. The first three parts of the IP address of all network components are in this case always the same.

Switch

A switch is a central distributor in a wired network, which, unlike a hub, provides intelligent distribution of data transfer. The switch only ever forwards a data packet to the subnet or network component the data packet is intended for. Unnecessary transfer of data in the network thus avoided.

TAE

Telecommunications connecting unit (German: **Telekommunikations-Anschlusseinheit**). Connector for connecting analogue telecommunications devices. F for phone, N for additional devices such as fax or answer machines.

TCP

Transmission Control Protocol. TCP is part of the [TCP/IP](#) protocol family. TCP handles data transport between communication partners (applications). TCP is a session-based transmission protocol, i.e. it sets up, monitors and terminates a connection for transporting data.

Glossary

TCP/IP

Transmission **C**ontrol **P**rotocol/**I**nternet **P**rotocol. Protocol family on which the Internet is based. IP forms the basis of each PC to PC connection. **TCP** provides applications with a reliable transmission link in the form of a continuous data stream. TCP/IP is the basis on which services such as WWW, Mail and News are built. There are other protocols as well. In order to access the Internet from a PC, TCP/IP must be set up on the PC.

UDP

User **D**atagram **P**rotocol. UDP is a **Protocol** of the **TCP/IP** protocol family that handles data transport between two communication partners (applications). Unlike **TCP**, UDP is a non-session based protocol. It does not establish a fixed connection. The recipient is responsible for making sure the data is received. The sender is not notified about whether it is received or not.

Uplink

Data that your SX682 WiMAX forwards from your PC or local network to external sites (e.g. to the Internet).

URL

Universal **R**esource **L**ocator. Globally unique address of a domain on the Internet, e.g. <http://www.sagemcom.com>.

Virtual server

A virtual **Server** provides a service on the Internet that runs not on itself, but on another network component. The SX682 WiMAX can be configured as a virtual server. It will then direct incoming calls for a service via **Port forwarding** directly to the appropriate **Port** of the network component in question.

VoIP

Voice **o**ver **I**nternet **P**rotocol; voice transmission via the Internet (Internet telephony).

WAN

Wide **A**rea **N**etwork. A WAN is a network that is not restricted to one particular area, such as the Internet. A WAN is run by one or more public providers to enable private access. You access the Internet via a **Provider**.

WiMAX

Worldwide **I**nteroperability for **M**icrowave **A**ccess. WiMAX is a modern wireless network technology that enables fast Internet connection even in remote areas where no other connection possibility (e. g. DSL) is available.

Index

A

Address Translation	75
Administration	43
system password	43
Advanced Settings	
features	33
Antenna	
adjusting	28
aligning precisely	30
integrated	14
outdoor antenna	15
Appendix	59
CE declaration	66
putting into service	66
specifications	65
troubleshooting	59

B

Base station ID	49
Basic settings	27
setting up Internet access	27
starting	27
Basic Setup Wizard	27
establishing a radio connection	28
starting	27
Bridge	75

C

Call forwarding	
activating/deactivating on the phone	57
Call holding	54
Call transfer	55
during conference	56
Care	5
Checking connection	62
Cleaning	5
Conference call	55
call transfer	56
end	56
Configuration	21
administration	43
aligning antenna precisely	30
basic settings	27

Configuration

menu structure	25
opening online Help	25
resetting to factory setting	44
setting the language	24
status	46
Confirmation tone	
positive	58
Connecting	16
answer machine	18
fax machine	18
outdoor antenna	16
PC	17
telephone	18
Connection mode	35
Connectors	10

D

dB	75
dBm	75
Device status	49
DHCP	75
DHCP server	39, 75
Disposal	6
Disposal (Switzerland)	5
DNS	76
DNS (Domain Name System)	36
DNS server	36
Domain name	76
DoS (Denial of Service)	40
Downlink	76
DSL	76

E

Enquiry	53
Establishing a radio connection	28
Ethernet	76
Exposed host	38

F

Factory settings	20
Faxing	51
Firewall	36, 76

Index

Firmware	76	Internet telephony	78
Firmware update	45	analogue telephone	40
Flat rate	76	setting up	40
Forwarding		VoIP settings	40
always	57	IP	78
on busy	57	IP address	21, 78
on no response	57	assigning automatically	39
FTP	77	assigning static	39, 40
Full duplex	77	dynamic	78
FXS	77	private	39, 78
G		public	78
Gateway	77	static	78
H		IP address block for DHCP	39
Hacker defence	36	IPTV	79
Half duplex	77	ISP	79
HTTP	77	L	
HTTP proxy	77	LAN	79
Firefox	63	configuration	39
Internet Explorer	63	Lease time	39
setting up	63	LED	79
Hub	77	LEDs	
I		overview	11
IEEE	77	startup	19
IEEE 802.16	78	Location	13
Installation		Login	79
connecting	16	M	
location	13	MAC address	79
PC	17	MAC table	40
resetting	19	ageing time	40
restarting	19	Making calls	51
switching on	18	calling	52
system requirements	15	receiving calls	52
Installing	13	Mbps	79
Internet	35	Menu structure	25
connection mode	35	N	
menu	35	NAT	37, 75
protocol	35	port forwarding	37
Internet access		Network	79
setting up	27	Network adapter	79
Internet connection		Network Address Translation	37
changing configuration	35	Network protocol	80
closing manually	26		
opening manually	26		
setting up	35		

- O**
- Opening online Help 25
 - Operating mode
 - Bridge 34
 - Router 34
 - Outdoor antenna 15
- P**
- Password
 - forgotten 60
 - ping command 62
 - Pop-up blocker
 - Firefox 64
 - Internet Explorer 64
 - Pop-up window 64
 - Firefox 64
 - Internet Explorer 64
 - Port 80
 - Port forwarding 37, 80
 - setting up 37
 - Port number 80
 - illustration 37
 - Positive confirmation tone 58
 - PPPoE pass-through 36
 - Product features 10
 - Product overview 10
 - Protocol 80
 - Provider 80
 - Putting into service 51
- Q**
- QoS 80
- R**
- Radio status 49
 - Reboot 45
 - Resetting 19, 44
 - Restarting 19
 - RJ 80
 - Router 80
 - RSSI 80
- S**
- Safety 5
 - disposal (Switzerland) 5
 - Safety precautions 5
 - Scan 28
 - Security
 - disposal 6
 - safety precautions 5
 - Server 81
 - virtual 82
 - Setting the language 24
 - Setting up Internet access 27
 - SIP 81
 - SMTP 81
 - Specifications 65
 - Status 46
 - device 49
 - Internet 47
 - LAN 48
 - local network 48
 - radio status 49
 - telephony 48
 - Subnet 81
 - Subnet mask 81
 - Switch 81
 - Switching on 18
 - System password 43
 - forgotten 60
 - System requirements 15
- T**
- TAE 81
 - TCP 81
 - TCP/IP 82
 - Telephone
 - analogue 40
 - Telephoning 52
 - function keys 52
 - Trademarks 5
 - Troubleshooting 59
 - customer service 61
 - fault tracing 59
 - other faults 60
- U**
- UDP 82
 - Updating firmware 45
 - Upgrading firmware 45
 - Uplink 82
 - URL 82
 - User Datagram Protocol see UDP

Index

User interface	23	Web browser	
Basic Setup Wizard	27	configuring	63
menu structure	25	HTTP proxy	63
opening online Help	25	launching user interface	21
setting the language	24	menu structure	25
		pop-up window	64
V		user interface	23
Virtual server	82	WiMAX	9, 82
VoIP	51, 82	WiMAX network	
		access data	27
W		establishing a connection	28
WAN	82	scan	28

Issued by Sagemcom Broadband SAS
Sagemcom Broadband SAS
250, route de l'Empereur - 92500 RUEIL MALMAISON

© Sagemcom Broadband SAS 2011
All rights reserved. Subject to availability.
Rights of modification reserved.

www.sagemcom.com

05.2011