

SAMSUNG



SAMSUNG LASER FACSIMILE User's Guide
SF-560 Series

For UK customers:

To reorder your consumables
Call 0800 3164060

For Technical Assistance
Call 0870 2420303

This manual is provided for information purposes only. All information included herein is subject to change without notice. Samsung Electronics is not responsible for any changes, direct or indirect, arising from or related to use of this manual.

© 2004 Samsung Electronics Co., Ltd. All rights reserved.

- SF-560 and Samsung logo are trademarks of Samsung Electronics Co., Ltd.
- All other brand or product names are trademarks of their respective companies or organizations.

CONTENTS

Chapter 1: GETTING STARTED

Setting Up Your Machine	1.2
Unpacking	1.2
Selecting a Location	1.3
Understanding the Component Location	1.4
Front View	1.4
Rear View	1.4
Control Panel Functions	1.5
Attaching Accessories	1.6
Document Output Support	1.6
Handset and Handset Cradle	1.7
Installing the Toner Cartridge	1.8
Loading Paper	1.9
Connecting the Telephone Line	1.11
Turning the Machine On	1.12
Setting Up the Machine System	1.13
Changing the Display Language	1.13
Setting the Machine ID	1.13
Entering Characters Using the Number Keypad	1.14
Setting the Date and Time	1.15
Changing the Clock Mode	1.16
Setting the Paper Type and Size	1.16
Setting Sounds	1.17
Speaker, Ringer, Key Sound and Alarm Sound	1.17
Speaker Volume	1.17
Using the Save Modes	1.18
Toner Save Mode	1.18
Toll Save Mode	1.18
Power Save Mode	1.19
Setting Up the Fax System	1.19
Available Fax Setup Options	1.20

Chapter 2: BASIC FUNCTIONS

Sending a Fax	2.2
Preparing a Document	2.2
Loading a Document	2.2
Adjusting the Document Resolution	2.3
Sending a Fax Automatically	2.4
Sending a Fax Manually	2.4
Redialing the Last Number	2.5
Confirming Transmission	2.5
Automatic Redialing	2.5

Receiving a Fax	2.6
About Receiving Modes	2.6
Loading Paper for Receiving Faxes	2.6
Receiving Automatically in Fax Mode	2.7
Receiving Manually in Tel Mode	2.7
Receiving Automatically in Ans/Fax Mode	2.7
Receiving Manually Using an Extension Telephone	2.8
Receiving Faxes Using the DRPD Mode	2.8
Receiving Faxes in the Memory	2.9
Making a Copy	2.10
Loading Paper for Copying	2.10
Setting the Paper Type and Size for the Manual Feeder	2.11
Making a Copy	2.12
Setting Copy Options	2.12
Darkness	2.12
Original Type	2.12
Number of Copies	2.13
Reduced/Enlarged Copying	2.13
Changing the Default Settings	2.14
Setting the Time Out Option	2.14
Collation Copying	2.15
Automatic Dialing	2.16
One-touch Dialing	2.16
Storing a Number for One-touch Dialing	2.16
Sending a Fax using a One-touch Number	2.16
Speed Dialing	2.17
Storing a Number for Speed Dialing	2.17
Sending a Fax using a Speed Number	2.17
Group Dialing	2.18
Setting a Group Dial Number	2.18
Editing Group Dial Numbers	2.19
Sending a Fax Using Group Dialing (Multi-address Transmission)	2.19
Searching for a Number in the Memory	2.20
Searching Sequentially through the Memory	2.20
Searching with a Particular First Letter	2.20
Printing a Phonebook List	2.20

Chapter 3: ADVANCED FAX FUNCTIONS

Sending Broadcasting Faxes	3.2
Sending a Delayed Fax	3.2
Sending a Priority Fax	3.4
Polling a Remote Machine	3.4
Adding Documents to a Scheduled Fax	3.6
Canceling a Scheduled Fax	3.6

Chapter 4: ADDITIONAL FEATURES

Using Secure Receiving Mode	4.2
Printing Reports	4.3
Using Advanced Fax Settings	4.4
Changing Setting Options	4.4
Advanced Fax Setting Options	4.4

Chapter 5: MAINTENANCE

Clearing the Memory	5.2
Adjusting Shading	5.3
Cleaning Your Machine	5.3
Cleaning the Outside	5.3
Cleaning the Inside	5.3
Cleaning the Scan Unit	5.4
Maintaining the Toner Cartridge	5.6
Redistributing Toner	5.6
Replacing the Toner Cartridge	5.7
Setting the Notify Toner Option	5.7
Cleaning the Drum	5.7
Ignoring the Toner Empty Message	5.8
Consumables and Replacement Parts	5.8
Replacing the ADF Rubber Pad	5.9

Chapter 6: TROUBLESHOOTING

Clearing Document Jams	6.2
Input Misfeed	6.2
Exit Misfeed	6.2
Clearing Paper Jams	6.3
In the Paper Tray	6.3
In the Paper Exit Area	6.4
In the Fuser Area or Around the Toner Cartridge	6.4
In the Manual Feeder	6.5
Tips for Avoiding Paper Jams	6.5
Clearing LCD Error Messages	6.6
Solving Problems	6.8
Paper Feeding Problems	6.8
Copying Problems	6.9
Faxing Problems	6.10

Appendix A: SPECIFICATIONS

General Specifications	A.2
Copier Specifications	A.3
Facsimile Specifications	A.4
Paper Specifications	A.5
Overview	A.5
Supported Sizes of Paper	A.5
Guidelines for Using Paper	A.6
Paper Specifications	A.6
Paper Storage Environment	A.7

Important Precautions and Safety Information

When using this machine, these basic safety precautions should always be followed to reduce risk of fire, electric shock, and injury to people:

1. Read and understand all instructions.
2. Use common sense whenever operating electrical appliances.
3. Follow all warnings and instructions marked on the machine and in the literature accompanying the machine.
4. If an operating instruction appears to conflict with safety information, heed the safety information. You may have misunderstood the operating instruction. If you cannot resolve the conflict, contact your sales or service representative for assistance.
5. Unplug the machine from the AC wall socket and/or telephone jack before cleaning. Do not use liquid or aerosol cleaners. Use only a damp cloth for cleaning.
6. Do not place the machine on an unstable cart, stand or table. It may fall, causing serious damage.
7. Your machine should never be placed on, near or over a radiator, heater, air conditioner or ventilation duct.
8. Do not allow anything to rest on the power cable. Do not locate your machine where the cords will be abused by persons walking on them.
9. Do not overload wall outlets and extension cords. This can diminish performance, and may result in the risk of fire or electric shock.
10. Do not allow pets to chew on the AC power, telephone or PC interface cords.
11. Never push objects of any kind into the machine through case or cabinet openings. They may touch dangerous voltage points, creating a risk of fire or shock. Never spill liquid of any kind onto or into the machine.
12. Your machine may have a heavy cover for optimal pressure on the document for the best scanning and/or faxing. In this case, replace the cover after placing document on the scan glass, by holding and moving it down slowly until it seats on its location.
13. To reduce the risk of electric shock, do not disassemble the machine. Take it to a qualified service technician when repair work is required. Opening or removing covers may expose you to dangerous voltages or other risks. Incorrect reassembly could cause electric shock when the unit is subsequently used.
14. Unplug the machine from the telephone jack, PC and AC wall outlet, and refer servicing to qualified service personnel under the following conditions:
 - When any part of the power cord, plug, or connecting cable is damaged or frayed.
 - If liquid has been spilled into the machine.
 - If the machine has been exposed to rain or water.
 - If the machine does not operate properly after instructions have been followed.
 - If the machine has been dropped, or the cabinet appears damaged.
 - If the machine exhibits a sudden and distinct change in performance.
15. Adjust only those controls covered by the operating instructions. Improper adjustment of other controls may result in damage, and may require extensive work by a qualified service technician to restore the machine to normal operation.
16. Avoid using this machine during a lightning storm. There may be a remote risk of electric shock from lightning. If possible, unplug the AC power and telephone cord for the duration of the lightning storm.
17. SAVE THESE INSTRUCTIONS.
18. Use only No.26 AWG or larger telephone line cord.

Laser Safety Statement

The printer is certified in the U.S. to conform to the requirements of DHHS 21 CFR, chapter 1 Subchapter J for Class I(1) laser products, and elsewhere is certified as a Class I laser product conforming to the requirements of IEC 825.

Class I laser products are not considered to be hazardous. The laser system and printer are designed so there is never any human access to laser radiation above a Class I level during normal operation, user maintenance, or prescribed service condition.

WARNING

Never operate or service the printer with the protective cover removed from Laser/Scanner assembly. The reflected beam, although invisible, can damage your eyes.



CAUTION - INVISIBLE LASER RADIATION
WHEN THIS COVER OPEN.
DO NOT OPEN THIS COVER.
VORSICHT - UNSICHTBARE LASERSTRAHLUNG,
WENN ABDECKUNG GEÖFFNET.
NICHT DEM STRAHL AUSSETZEN.

- ATTENTION - RAYONNEMENT LASER INVISIBLE EN CAS
D'OUVERTURE. EXPOSITION DANGEREUSE
AU FAISCEAU.
- ATTENZIONE - RADIAZIONE LASER INVISIBLE IN CASO DI
APERTURA. EVITARE L'ESPOSIZIONE AL FASCIO.
- PRECAUCIÓN - RADIACIÓN LASER INVISIBLE CUANDO SE ABRE.
EVITAR EXPONERSE AL RAYO.
- PERIGO - RADIAÇÃO LASER INVISÍVEL AO ABRIR. EVITE
EXPOSIÇÃO DIRECTA AO FEIXE.
- GEVAAR - ONZICHTBARE LASERSTRALLEN BIJ GEOPENDE
KLEP. DEZE KLEP NIET OPENEN.
- ADVARSEL - USYNLIG LASERSTRÅLNING VED ÅBNING. NÅR
SIKKERHEDSBRYDERE ER UDE AF FUNKTION.
UNNGÅ UDSAETTELSE FOR STRÅLNING.
- ADVARSEL - USYNLIG LASERSTRÅLNING NÅR DEKSEL
ÅPNES. STIRR IKKE INN I STRÅLEN. UNNGÅ
EKSPONERING FOR STRÅLEN.
- VARNING - OSYNLIG LASERSTRÅLNING NÅR DENNA DEL
ÅR ÖPPEN OCH SPÅRREN ÅR URKOPPLAD.
BETRAKTA EJ STRÅLEN. STRÅLEN ÅR FARLIG.
- VARO! - AVATTAESSA JA SUOJALUKITUS OHITETTAESSA
OLET ALTTIINA NÄKYMÄTTÖMÄLLE LASER-
SÄTEILYLLE ÄLÄ KATSO SÄTEESEEN.
- 注 意** - 严禁揭开此盖, 以免激光泄露灼伤
- 주 의** - 이 덮개를 열면 레이저광에 노출될 수 있으므로
주의하십시오.

Ozone Safety



During normal operation, this machine produces ozone. The ozone produced does not present a hazard to the operator. However, it is advisable that the machine be operated in a well ventilated area.

If you need additional information about ozone, please request your nearest Samsung dealer.

Power Saver



This machine contains advanced energy conservation technology that reduces power consumption when it is not in active use.

When the machine does not receive data for an extended period of time, power consumption is automatically lowered.

The energy star emblem does not represent EPA endorsement of any machine or service.

Recycling

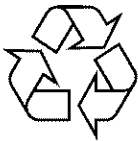

Please recycle or dispose of the packaging material for this product in an environmentally responsible manner.

Radio Frequency Emissions

FCC Information to the User

This equipment has been tested and found to comply with the limits for a Class B digital device, pursuant to Part 15 of the FCC Rules. These limits are designed to provide reasonable protection against harmful interference in a residential installation. This equipment generates, uses and can radiate radio frequency energy and, if not installed and used in accordance with the instructions, may cause harmful interference to radio communications. However, there is no guarantee that interference will not occur in a particular installation. If this equipment does cause harmful interference to radio or television reception, which can be determined by turning the equipment off and on, the user is encouraged to try to correct the interference by one or more of the following measures:

- Reorient or relocate the receiving antenna.
- Increase the separation between the equipment and receiver.
- Connect the equipment into an outlet on a circuit different from that to which the receiver is connected.
- Consult the dealer or experienced radio TV technician for help.

CAUTION: Change or modifications not expressly approved by the manufacturer responsible for compliance could void the user's authority to operate the equipment.

Canadian Radio Interference Regulations

This digital apparatus does not exceed the Class B limits for radio noise emissions from digital apparatus as set out in the interference-causing equipment standard entitled "Digital Apparatus", ICES-003 of the Industry and Science Canada.

Cet appareil numérique respecte les limites de bruits radioélectriques applicables aux appareils numériques de Classe B prescrites dans la norme sur le matériel brouilleur: "Appareils Numériques", ICES-003 édictée par l'Industrie et Sciences Canada.

Fax Branding

The Telephone Consumer Protection Act of 1991 makes it unlawful for any person to use a computer or other electronic device to send any message via a telephone facsimile machine unless such message clearly contains in a margin at the top or bottom of each transmitted page or on the first page of the transmission the following information:

- (1) the date and time of transmission
- (2) identification of either business, business entity or individual sending the message; and
- (3) telephone number of either the sending machine, business, business entity or individual.

The Telephone Company may make changes in its communications facilities, equipment operations, or procedures where such action is reasonably required in the operation of its business and is not inconsistent with the rules and regulations in FCC Part 68. If such changes can be reasonably expected to render any customer terminal equipment incompatible with telephone company communications facilities, or require modification or alteration of such terminal equipment, or otherwise materially affect its use or performance, the customer shall be given adequate notice in writing, to allow the customer an opportunity to maintain uninterrupted service.

Ringer Equivalence Number

The Ringer Equivalence Number and FCC Registration Number for this machine may be found on the label located on the bottom or rear of the machine. In some instances you may need to provide these numbers to the telephone company.

The Ringer Equivalence Number (REN) is a measure of the electrical load placed on the telephone line, and is useful for determining whether you have "overloaded" the line. Installing several types of equipment on the same telephone line may result in problems making and receiving telephone calls, especially ringing when your line is called. The sum of all Ringer Equivalence Numbers of the equipment on your telephone line should be less than five in order to assure proper service from the telephone company. In some cases, a sum of five may not be usable on your line. If any of your telephone equipment is not operating properly, you should immediately remove it from your telephone line, as it may cause harm to the telephone network.

WARNING:

FCC Regulations state that changes or modifications to this equipment not expressly approved by the manufacturer could void the user's authority to operate this equipment. In the event that terminal equipment causes harm to the telephone network, the telephone company should notify the customer that service may be stopped. However, where prior notice is impractical, the company may temporarily cease service, providing that they:

- a) promptly notify the customer.
- b) give the customer an opportunity to correct the equipment problem.
- c) inform the customer of the right to bring a complaint to the Federal Communication Commission pursuant to procedures set out in FCC Rules and Regulations Subpart E of Part 68.

You should also know that:

- Your machine is not designed to be connected to a digital PBX system.
- If you intend to use a computer modem or fax modem on the same phone line as your machine, you may experience transmission and reception problems with all the equipment. It is recommended that no other equipment, except for a regular telephone, share the line with your machine.
- If your area experiences a high incidence of lightning or power surges, we recommend that you install surge protectors for both the power and the telephone lines. Surge protectors can be purchased from your dealer or telephone and electronic specialty stores.
- When programming emergency numbers and/or making test calls to emergency numbers, use a non-emergency number to advise the emergency service dispatcher of your intentions. The dispatcher will give you further instructions on how to actually test the emergency number.
- This machine may not be used on coin service or party lines.
- This machine provides magnetic coupling to hearing aids.
- You may safely connect this equipment to the telephone network by means of a standard modular jack, USOC RJ-11C.
- Connection to ISDN, ADSL or other advanced telecommunication system may require additional equipment.

Declaration of Conformity (European Countries)

Approvals and Certifications



The CE marking applied to this product symbolizes Samsung Electronics Co., Ltd. Declaration of Conformity with the following applicable 93/68/EEC Directives of the European Union as of the dates indicated:

January 1, 1995: Council Directive 73/23/EEC Approximation of the laws of the member states related to low voltage equipment.

January 1, 1996: Council Directive 89/336/EEC (92/31/EEC), approximation of the laws of the Member States related to electromagnetic compatibility.

March 9, 1999: Council Directive 1999/5/EC on radio equipment and telecommunications terminal equipment and the mutual recognition of their conformity.

A full declaration, defining the relevant Directives and referenced standards can be obtained from your Samsung Electronics Co., Ltd. representative.

EC Certification

Certification to 1999/5/EC Radio Equipment & Telecommunications Terminal Equipment Directive (FAX)

This Samsung product has been self-certified by Samsung for pan-European single terminal connection to the analogue public switched telephone network (PSTN) in accordance with Directive 1999/5/EC. The product has been designed to work with the national PSTNs and compatible PBXs of the European countries:

In the event of problems, you should contact the Euro QA Lab of Samsung Electronics Co., Ltd. in the first instance.

The product has been tested against TBR21. To assist in the use and application of terminal equipment which complies with this standard, the European Telecommunication Standards Institute (ETSI) has issued an advisory document (EG 201 121) which contains notes and additional requirements to ensure network compatibility of TBR21 terminals. The product has been designed against, and is fully compliant with, all of the relevant advisory notes contained in this document.

Replacing the Fitted Plug (for UK Only)

IMPORTANT

The mains lead for this machine is fitted with a standard (BS 1363) 13 amp plug and has a 13 amp fuse. When you change or examine the fuse, you must re-fit the correct 13 amp fuse. You then need to replace the fuse cover. If you have lost the fuse cover, do not use the plug until you have another fuse cover.

Please contact the people from you purchased the machine.

The 13 amp plug is the most widely used type in the UK and should be suitable. However, some buildings (mainly old ones) do not have normal 13 amp plug sockets. You need to buy a suitable plug adaptor. Do not remove the moulded plug.

WARNING

If you cut off the moulded plug, get rid of it straight away.

You cannot rewire the plug and you may receive an electric shock if you plug it into a socket.

IMPORTANT WARNING: You must earth this machine.

The wires in the mains lead have the following color code:

- Green and Yellow: Earth
- Blue: Neutral
- Brown: Live

If the wires in the mains lead do not match the colors marked in your plug, do the following:

You must connect the green and yellow wire to the pin marked by the letter "E" or by the safety 'Earth symbol' or colored green and yellow or green.

You must connect the blue wire to the pin which is marked with the letter "N" or colored black.

You must connect the brown wire to the pin which is marked with the letter "L" or colored red.

You must have a 13 amp fuse in the plug, adaptor, or at the distribution board.



ELECTRONICS

EU Declaration of Conformity (RTTE)

We, Samsung Electronics Co., Ltd.

of #259, GongDan-Dong, Gumi-City, Kyung-Buk, KOREA 730-030
of Sanxing Road, Weihai Hi-Tech, IDZ Shandong Province, China 264209
(factory name, address)

declare under our sole responsibility that the product
Multi-function Facsimile
model "SF-565P, SF-560,
FAX1170L/F250/LF125m/IF3035,
FAX1130L/F230/LF120/IF3030"

to which this declaration relates is in conformity with

RTTE Directive 1999/5/EC (Annex II)
Low Voltage Directive 73/23/EEC
EMC Directive 89/336/EEC:92/31/EEC

By application of the following standards

RTTE : TBR 21, TBR 38, EG 201 121

LVD : EN 60950-1:2001

EMC : EN55022:1998, EN55024:1998 + A1:2001, EN61000-3-2:2000,

EN61000-3-3:1995 + A1:2001

(Manufacturer)

Samsung Electronics co.,ltd
#259,KangDan-Dong,Gumi-City
KyungBuk, Korea 710-010

2004-01-12

.....
(place and date of issue)

Whan-Soon Yim / General Manager

.....
(name and signature of authorized person)

(Representative in the EU)

Samsung Electronics Euro QA Lab.
Blackbushe Business Park
Saxony Way, Yateley, Hampshire
GU46 6GG, UK

2004-01-12

.....
(place and date of issue)

In-Seop Lee / Manager

.....
(name and signature of authorized person)

Differences Between British and American English

British English	American English
(Re)dialling	(Re)dialing
Colour	Color
Emphasise	Emphasize
Recognise	Recognize
Organise	Organize
Authorise	Authorize
Cancelling	Canceling
Customise	Customize
Socket	Jack

WARNING

- Do not disassemble the machine as it may give you an electric shock.
- If you print large amount of copies, the surface of the output tray may become hot. Be careful not to touch the surface, especially for children.

1

GETTING STARTED

Thank you for purchasing this facsimile.

This chapter gives you step-by-step instructions for setting up your machine.

This chapter includes:

- **Setting Up Your Machine**
- **Setting Up the Machine System**

Setting Up Your Machine

Unpacking

Remove the machine and all accessories from the packing carton. Make sure that the machine has been packed with the following items. If there is a missing item, contact the retailer where you bought the machine:

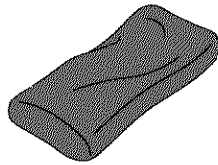

Starter Toner Cartridge

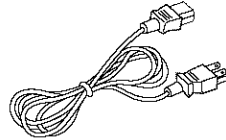

AC Power Cord*

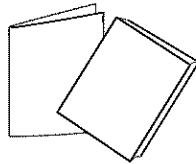

Quick Install Guide & User's Guide

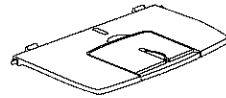

Document Output Support

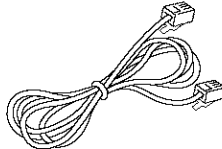

Telephone Line Cord*

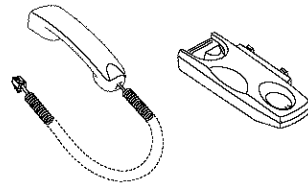

Handset & Cradle



TAM Lead (for UK only)

* The appearance of the power cord and the telephone line cord may differ according to your country's specifications.



NOTE:

- You should use the telephone line cord which is supplied with your machine. If you are replacing it with another vendor's, it should be AWG #26 or larger telephone line cord.
- The power cord must be plugged into a grounded power socket.
- Components may differ from one country to another.

Remove the packing tape from the front, back and sides of the machine.

1

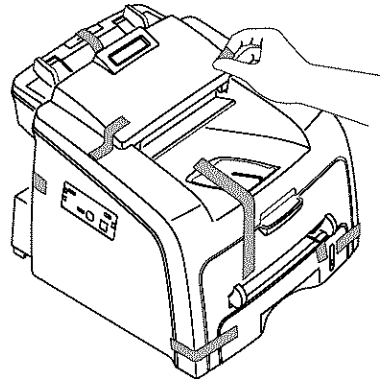

Selecting a Location

Select a level, stable place with adequate space for air circulation. Allow extra space for opening covers and trays.

The area should be well-ventilated and away from direct sunlight or sources of heat, cold and humidity. Do not set the machine close to the edge of your desk or table.

Clearance Space

- **Front:** 482.6 mm (enough space so that the paper tray can be removed)
- **Back:** 250 mm (enough space for ventilation)
- **Right:** 100 mm
- **Left:** 100 mm (enough space for ventilation)

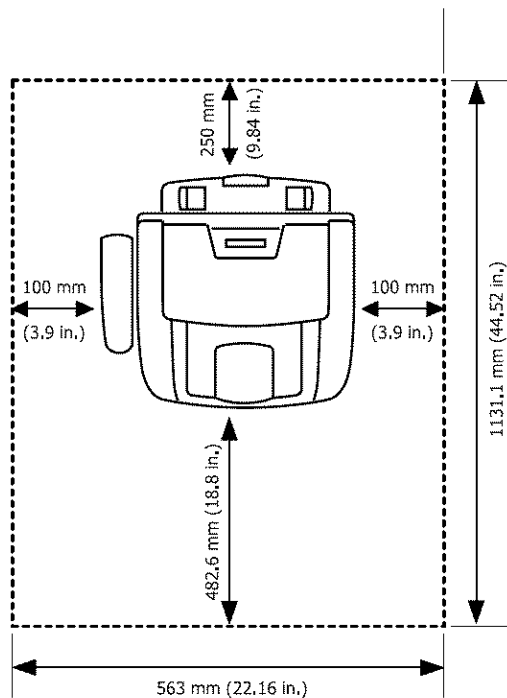

Understanding the Component Location

These are the main components of your machine:

Front View

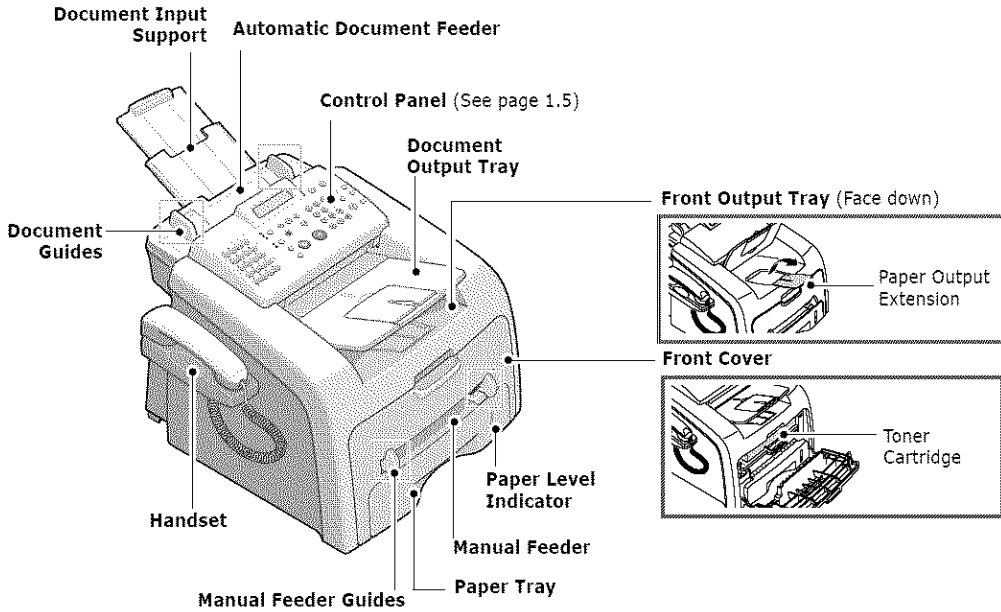

Rear View

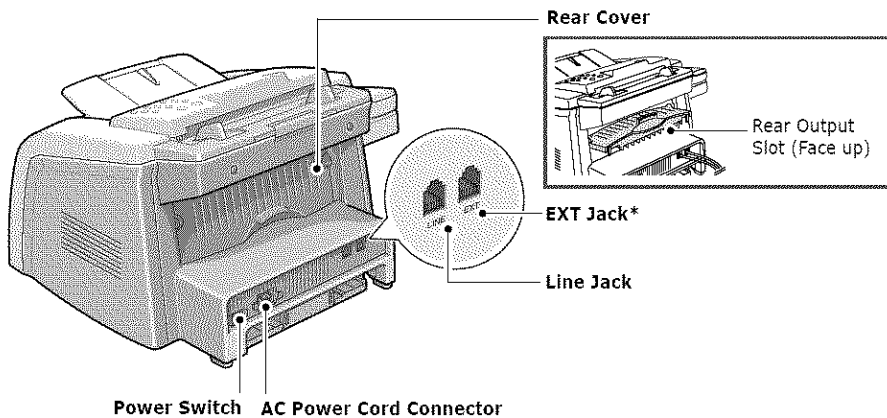





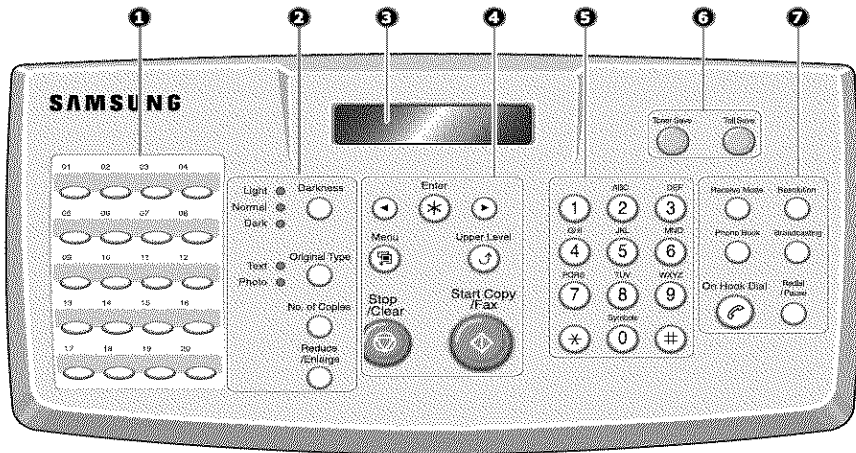



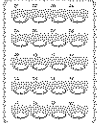



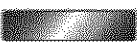







* If your country has a different telephone connection system, this socket may be blocked.

Control Panel Functions



1

1		Use to store frequently-dialed fax number and dial them with a touch of the buttons.
2 C O P Y	Darkness 	Adjusts the brightness of the documents for the current copy job.
	Original Type 	Selects the document type for the current copy job.
	Reduce /Enlarge 	Makes a copy smaller or larger than the original document.
	No. of Copies 	Selects the number of copies.
3		Displays the current status and prompts during an operation.
4		Scrolls through the options available for the selected menu item.
	Enter 	Confirms the selection on the display.
	Menu 	Enters Menu mode and scrolls through the menus available.
	Upper Level 	Sends you back to the upper menu level.
	Stop /Clear 	Stops an operation at any time. In Standby mode, clears/cancels the copy options, such as the darkness, the document type setting, the copy size and the number of copies.
	Start Copy /Fax 	Starts a job.

5		Dials a number or enters alphanumeric characters.
6		Allows you to save on toner by using less toner to print a document.
		Allows you to save on call costs by sending a fax at a preset toll-saving time. Using this feature, you can take advantage of lower long distance rates at night, for example.
7 F A X		Allows you to select the fax receiving mode.
		<ul style="list-style-type: none"> Allows you to store frequently-dialed fax numbers using a one or two-digit speed dial or group number for automatic dialing and edit the stored numbers. Allows you to print a Phonebook list.
		Adjusts the resolution of the documents for the current fax job.
		Allows you to send a fax to multiple destinations.
		Engages the telephone line.
		Redials the last number in Standby mode or inserts a pause into a fax number in Edit mode.

Attaching Accessories

Document Output Support

Insert the two tabs on the supplied document output support into the slots on both sides of the paper output tray.

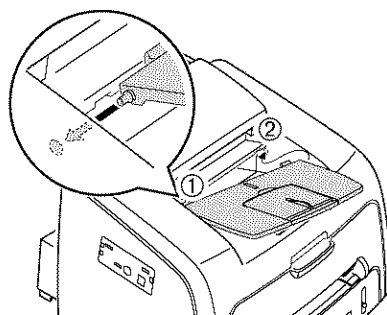

Fold out the extender, if necessary.



NOTE: When detaching the document output tray, detach it by pressing the front portion of document output tray as seen from the picture. As this time, even though the dull sound is heard the components are safe from damage.

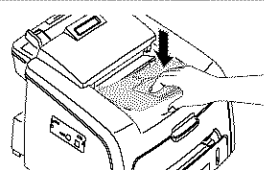

Handset and Handset Cradle

- 1 Plug the end of the coiled cord of the handset into the jack on the left side of your machine.

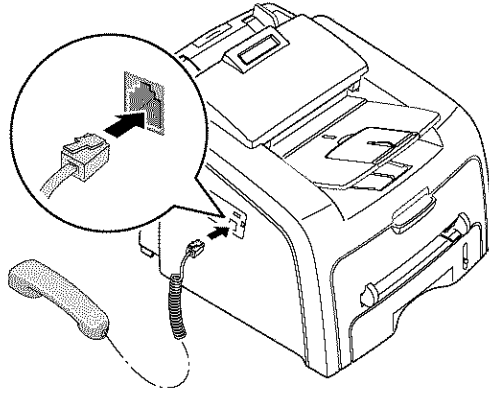

- 2 Holding the cradle as shown, attach the handset cradle to the machine.
 - ① Insert the two tabs of the cradle into the slots on the left side of the machine as shown.
 - ② Push the cradle toward the machine until it locks into place.

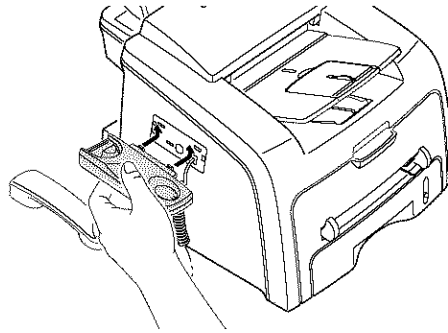

NOTE:

- The cradle and handset must be installed for correct operation of the set
- To remove the cradle, push it down, pressing the latch on the bottom of the cradle.

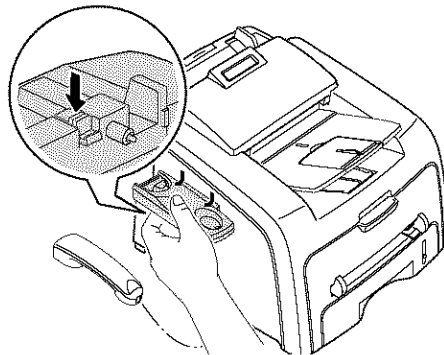

Installing the Toner Cartridge

- 1 Open the front cover.

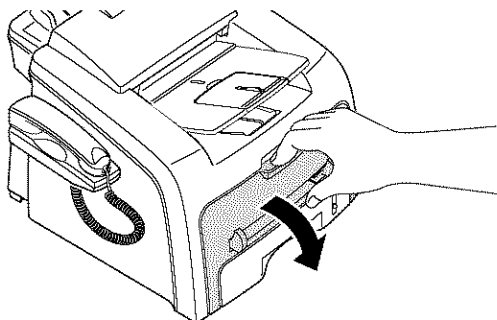

- 2 Remove the starter toner cartridge from its bag. Gently roll the cartridge 5 or 6 times to distribute the toner evenly inside the cartridge.

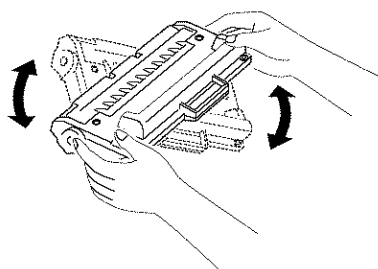

Thoroughly rolling the cartridge will assure the maximum copies per cartridge.



NOTES:

- To prevent damage to the toner cartridge, do not expose it to light for more than a few minute. Cover it with a piece of paper, if necessary.
- If the toner gets on your clothing, wipe it off with a dry cloth and wash clothing in cold water. Hot water sets the toner into fabric.

- 3 Slide the toner cartridge into the machine until it locks into place completely.

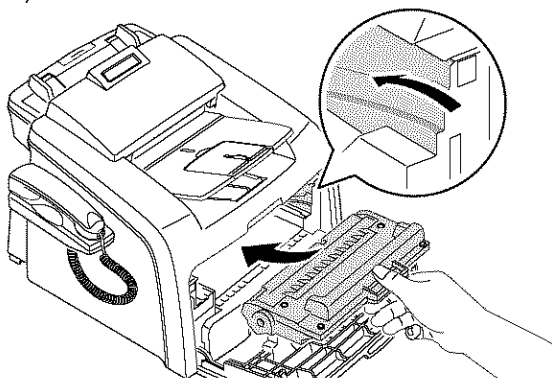

- 4 Close the front cover. Make sure that the cover is securely latched.

Loading Paper

You can load approximately 250 sheets.

To load a stack of Letter-sized paper:

- 1 Pull open the paper tray and remove it from the machine.

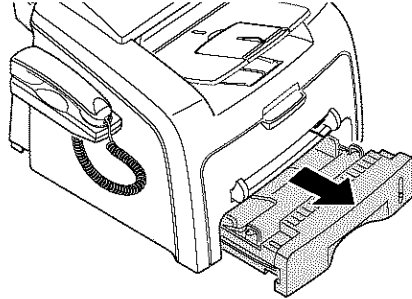

- 2 Push down on the pressure plate until it locks into place.

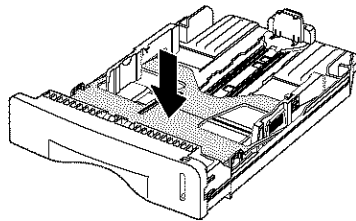

- 3 Fan the edges of the paper stack to separate the pages. Then tap the stack on a flat surface to even it up.
- 4 Insert the paper stack into the paper tray with the side you want to print facing up.

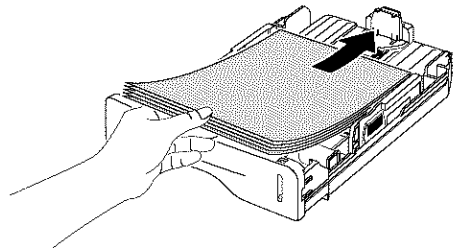

NOTE: If you want to load a different size of paper, you need to adjust the paper guides. For details, see page 1.10.

- 5 Pay attention to the paper limit mark on the left inside wall of the tray. Paper overloading may cause paper jams.
- 6 Insert and slide the paper tray back into the machine.



NOTE: After you load the paper, you need to set up your machine for the paper type and size you loaded. See page 1.16.

Changing the Paper Size in the Paper Tray

To load longer sizes of paper, such as Legal-sized paper, you need to adjust the paper guides to extend the paper tray.

- 1 After pressing and unlatching the guide lock, slide the paper length guide out completely to extend the paper tray to its full length.

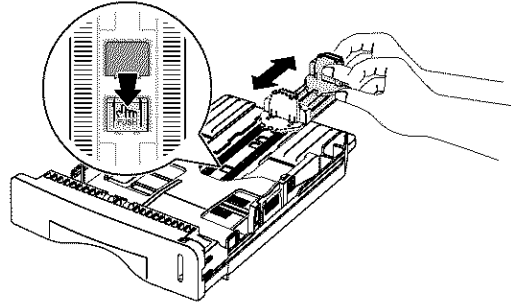

- 2 After inserting paper into the tray, slide in the guide until it lightly touches the end of the paper stack.
- 3 Pinching the paper width guide as shown, move it toward the stack of paper until it lightly touches the side of the stack.

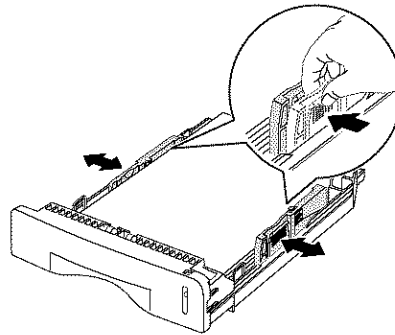

NOTES:

- Do not push the paper width guide far enough to cause the materials to warp.
- If you do not adjust the paper width guide, it may cause paper jams.

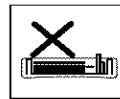
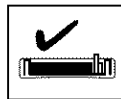

Connecting the Telephone Line

- 1 Plug the telephone line cord into the **LINE** jack and the other end into the wall jack.

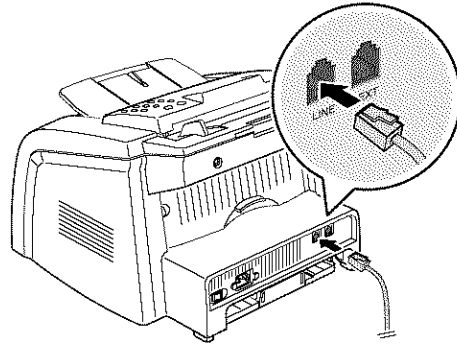

→ To the wall jack

- 2 To connect a telephone and/or answering machine to your machine, plug the cord of your extension phone or answering machine into the **EXT** jack.

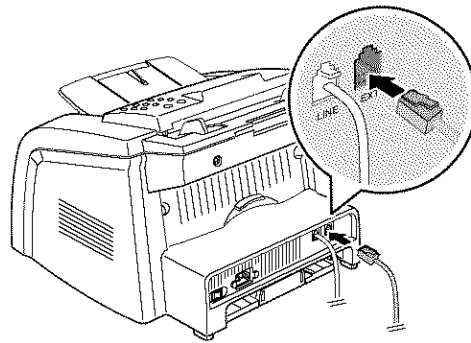

→ To an extension phone or answering machine

UK users should plug the cord of the extension phone into the supplied TAM lead and plug the cord of the TAM lead into the **EXT** jack on the back of your machine.

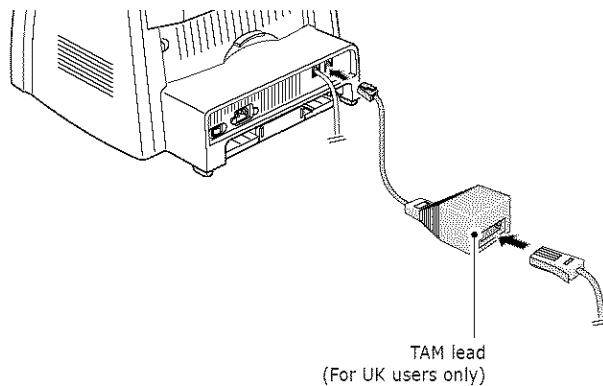

**NOTES:**

- Use the TAM lead and the telephone line cord supplied with your machine.
- In the United Kingdom, if a three-wire type (SHUNT-wire, older equipment) telephone or answering machine is connected to the EXT jack on the machine, the external equipment will fail to ring when receiving an incoming call as the machine is designed to operate with the latest technology. To prevent this incompatibility, use two-wire (newer equipment) telephone or answering machines.

Turning the Machine On

- 1 Plug one end of the supplied three-pronged electrical type cord into the AC socket on the machine and the other end into a properly grounded AC outlet.
- 2 Press the power switch to turn the machine on. "Warming Up Please Wait" appears on the display indicating that the machine is now on.

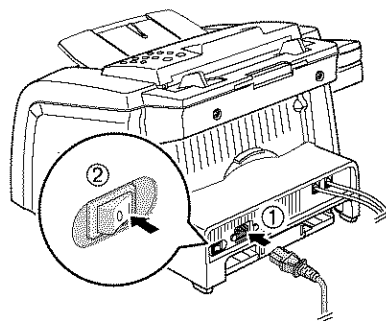

→ To the AC wall jack

To view your display text in another language, see the next page.

**CAUTIONS:**

- The fusing area inside the rear part of your machine becomes hot once the machine is turned on. Be careful when you access this area.
- Do not disassemble the machine when it turned on as it may give you an electric shock.

Setting Up the Machine System

Changing the Display Language

To change the language that displays on the display of the control panel, follow these steps:

- 1 Press **Menu** until "Machine Setup" appears on the top line of the display.
- 2 Press the scroll button (◀ or ▶) until "Language" appears on the bottom line of the display.
- 3 Press **Enter**. The current setting appears on the bottom line of the display.
- 4 Press the scroll button (◀ or ▶) until the language you want appears on the display.
- 5 Press **Enter** to save the selection.
- 6 To return to Standby mode, press **Stop/Clear**.

Setting the Machine ID

In some countries, you are required by law to indicate your fax number on any fax you send. The Machine ID, containing your telephone number and name or company name, will be printed at the top of each page sent from your machine.

- 1 Press **Menu** until "Machine Setup" appears on the top line of the display. The first available menu item, "Machine Id" displays on the bottom line.
- 2 Press **Enter**. The display asks you to enter the fax number.
If there is a number already set, the number appears.
- 3 Enter your fax number using the number keypad.



NOTE: If you make a mistake while entering numbers, press the ◀ button to delete the last digit.

- 4 Press **Enter** when the number on the display is correct. The display asks you to enter the ID.

- 5 Enter your name or company name using the number keypad.

You can enter alphanumeric characters using the number keypad, and include special symbols by pressing the **0** button.

For details on how to use the number keypad to enter alphanumeric characters, see the following section.

If you want to enter the same letter or number in succession (e.g. SS, AA, 777), enter one digit, move the cursor by pressing the **▶** button and enter the next digit.

If you want to insert a space in the name, you can also use the **▶** button to move the cursor to skip the position.

- 6 Press **Enter** when the name on the display is correct.

- 7 Press **Stop/Clear** to return to Standby mode.

Entering Characters Using the Number Keypad

As you perform various tasks, you need to enter names and numbers. For example, when you set up your machine, you enter your name or your company's name and telephone number. When you store one or two digit speed dial or group dial numbers, you may also enter the corresponding names.

To enter alphanumeric characters:

- 1 When you are prompted to enter a letter, locate the button labeled with the character you want. Press the button until the correct letter appears on the display.

For example, to enter the letter **O**, press **6**, labeled with "MNO."

Each time you press **6**, the display shows a different letter, **M**, **N**, **O** and finally **6**.

You can enter special characters, such as space, plus sign, and so on. For details, see "Keypad Letters and Numbers" on page 1.15.

- 2 To enter additional letters, repeat step 1.

If the next letter is printed on the same button, move the cursor by pressing the **▶** button and then press the button labeled with the letter you want. The cursor moves to the right and the next letter appears on the display.

You can enter a space by pressing the **#** button.

- 3 When you finish entering letters, press **Enter**.

Keypad Letters and Numbers

Key	Assigned numbers, letters or characters
1	1 Space
2	A B C 2
3	D E F 3
4	G H I 4
5	J K L 5
6	M N O 6
7	P Q R S 7
8	T U V 8
9	W X Y Z 9
0	+ - , . ' / * # & 0

Changing Numbers or Names

If you make a mistake while entering a number or name, press the ◀ button to delete the last digit or character. Then enter the correct numbers or characters.

Inserting a Pause

With some telephone systems, you must dial an access code (9, for example) and listen for a second dial tone. In such cases, you must insert a pause in the telephone number. You can insert a pause while you are setting up one-touch or speed dial numbers.

To insert a pause, press **Redial/Pause** at the appropriate place while entering the telephone number. A “-” appears on the display at the corresponding location.

Setting the Date and Time

The current date and time are shown on the display when your machine is on and ready to work. All of your faxes will have the date and time printed on them.



NOTE: If power to the machine is cut off, you need to reset the correct time and date once the power is restored.

- 1 Press **Menu** until “Machine Setup” appears on the top line of the display.
- 2 Press the scroll button (◀ or ▶) to display “Date & Time” on the bottom line and press **Enter**.
- 3 Enter the correct time and date using the number keypad.
 - Month = 01 ~ 12
 - Day = 01 ~ 31
 - Year = requires all four digits
 - Hour = 01 ~ 12 (12-hour mode)
00 ~ 23 (24-hour mode)
 - Minute = 00 ~ 59



NOTE: The date format may differ from each country.

You can also use the scroll button (◀ or ▶) to move the cursor under the digit you want to correct and enter a new number.

- 4 To select "AM" or "PM" for 12-hour format, press the * or # button or any number button.

When the cursor is not under the AM or PM indicator, pressing the * or # button immediately moves the cursor to the indicator.

You can change the clock mode to 24-hour format (e.g. 01:00 PM as 13:00). For details, see page 1.16.

- 5 Press **Enter** when the time and date on the display is correct.

When you enter a wrong number, the machine beeps and does not proceed to the next step. If this happens, just reenter the correct number.

Changing the Clock Mode

You can set your machine to display the current time using either 12-hour or 24-hour format.

- 1 Press **Menu** until "Machine Setup" appears on the top line of the display.
- 2 Press the scroll button (◀ or ▶) until you see "Clock Mode" on the bottom line and press **Enter**.
The clock mode currently set for the machine displays.
- 3 Press the scroll button (◀ or ▶) to select the other mode and then press **Enter** to save the selection.
- 4 To return to Standby mode, press **Stop/Clear**.

Setting the Paper Type and Size

After loading paper in the paper tray, you need to set the paper type and size using the control panel buttons.

- 1 Press **Menu**.
The display shows "Paper Setting" on the top line and the first menu item, "Paper Type," on the bottom line.
- 2 Press **Enter** to access the menu item.
- 3 Use the scroll button (◀ or ▶) to fine the paper type you are using and press **Enter** to save it.
- 4 Press the ▶ button to scroll to "Paper Size" and press **Enter** to access the menu item.
- 5 Press **Enter** when "Tray Paper " displays on the bottom line.
- 6 Use the scroll button (◀ or ▶) to find the paper size you are using and press **Enter** to save it.
- 7 To return to Standby mode, press **Stop/Clear**.

Setting Sounds

You can control the following sounds:

- **Ringer:** You can adjust the ringer volume.
- **Key Sound:** With this option set to "On," a key tone sounds each time any key is pressed.
- **Alarm Sound:** You can turn the alarm sound on or off. With this option set to "On," an alarm tone sounds when an error occurs or fax communication ends.
- **Speaker:** You can turn on or off the sounds from the telephone line through the speaker, such as a dial tone or a fax tone. With this option set to "Comm.," the speaker is on until the remote machine answers.

You can adjust the speaker volume level using the **On Hook Dial** button or the handset.

Speaker, Ringer, Key Sound and Alarm Sound

- 1 Press **Menu** until "Sound/Volume" appears on the top line of the display.
- 2 Press the scroll button (◀ or ▶) to scroll through the options. Press **Enter** when you see the sound option you want.
- 3 Press the scroll button (◀ or ▶) to display the status or loudness you want for the option you have selected.

For the ringer volume, you can select from "Off", "Low", "Med" and "High." Setting "Off" means that the ringer turns off. The machine works normally even if the ringer is turned off.

- 4 Press **Enter** to save the selection.
- 5 If necessary, repeat steps 2 through 4.
- 6 To return to Standby mode, press **Stop/Clear**.

Speaker Volume

To adjust the volume using the **On Hook Dial** button:

- 1 Press **On Hook Dial**. A dial tone sounds from the speaker.
- 2 Press the scroll button (◀ or ▶) until you hear the loudness you want. The display shows the current volume level.
- 3 Press **Stop/Clear** to save the change and return to Standby mode.

To adjust the volume using the handset:(For USA only)

- 1 Pick up the handset. A dial tone sounds from the earpiece.
- 2 Press the scroll button (◀ or ▶) until you find the loudness you want. You can select either "High" or "Low."
- 3 Press **Enter** to save the selection and replace the handset.



NOTE: You can adjust the speaker volume only when the telephone line is connected.

Using the Save Modes

Toner Save Mode

Toner Save mode allows your machine to use less toner on each page. Activating this mode extends the life of the toner cartridge longer than normal, but it reduces the print quality.

To turn the toner save mode on or off, press **Toner Save**.

- If the button backlight is on, the mode is active and the machine uses less toner when printing a document.
- If the button backlight is off, the mode is deactivated and the machine prints with the normal quality.

Toll Save Mode

Using the **Toll Save** button on the control panel, you can quickly set your machine to send the document(s) stored in the memory during the preset time slot, when the call charge is lowered. This Toll Save mode helps you to take advantage of lower long distance rates at night, for example.



NOTE: The toll-saving time slot may vary depending on your contract with along distance phone company.

To turn the toll save mode on:

- 1 Press **Toll Save**. The button backlight turns on.
- 2 Press **Enter** when "Start Time" displays on the bottom line.
- 3 Enter the time when your machine starts sending toll save faxes, using the number keypad.
To select "AM" or "PM" for 12-hour format, press the * or # button or any number button.
- 4 Press **Enter** when the starting time on the display is correct.
- 5 Press the scroll button (◀ or ▶) to display "End Time" and press **Enter**.
- 6 Enter the time when the toll save transmission ends, using the number keypad.
- 7 Press **Enter** to save the setting.
- 8 To return to Standby Mode, press **Stop/Clear**.

Once Toll Save mode is activated, your machine stores all of the documents to be faxed into the memory and sends them at the programed time.

To turn Toll Save mode off, press **Toll Save** again. The button backlight turns off and the mode is deactivated.



NOTE: Once the toll-saving time is set, the **Toll Save** button allows you to only enable or disable the toll save mode. To change the time setting, use the Toll Save item in the Advanced Fax menu. See page 4.5.

Power Save Mode

Power Save mode allows your machine to reduce power consumption when it is not in actual use. You can turn this mode on by selecting the length of time for which the machine waits after a job is printed before it switches to a reduced power state.

- 1 Press **Menu** until "Machine Setup" appears on top line of the display.
- 2 Press the scroll button (◀ or ▶) until "Power Save" appears on the bottom line. Press **Enter**.
- 3 Press the scroll button (◀ or ▶) to display "On" on the bottom line and press **Enter**.
Selecting "Off" means that the power save mode turns off.
- 4 Press the scroll button (◀ or ▶) until the time settings you want appears.
The available options are 5, 10, 15, 30 and 45 (minutes).
- 5 Press **Enter** to save the selection.
- 6 To return to Standby mode, press **Stop/Clear**.

Setting Up the Fax System

Your machine has various user-selectable fax setup options. These options are preset at the factory, but you may need to change them.

- 1 Press **Menu** until "Fax Setup" appears on the top line of the display.
The first available menu item, "Ring to Answer," displays on the bottom line.
- 2 Press the scroll button (◀ or ▶) until the menu item you want on the bottom line and press **Enter**.
- 3 Use the scroll button (◀ or ▶) to find the status or use the number keypad to enter the value for the option you have selected.
- 4 Press **Enter** to save the selection.
- 5 If necessary, repeat steps 2 through 4.
- 6 To return to Standby mode, press **Stop/Clear**.

Available Fax Setup Options

You can use the following setup options for configuring the fax system:

Option	Description
Ring to Answer	You can specify the number of times the machine rings, 1 to 7, before answering an incoming call.
Darkness	You can select the default darkness mode to fax your documents lighter or darker. <ul style="list-style-type: none">• Light works well with dark print.• Normal works well with standard typed or printed documents.• Dark works well with light print or faint pencil markings.
Redial Term	Your machine can automatically redial a remote fax machine when the line is busy. Intervals from 1 to 15 minutes can be entered.
Redials	You can specify the number of redial attempts, 0 to 13. If you enter 0 , the machine will not redial.
MSG Confirm	You can set your machine to print a report showing whether the transmission was successful, how many pages were sent, and more. The available options are On , Off and On-Error , which prints only when a transmission is not successful.
Auto Report	A report with detailed information about the previous 50 communications operations, including time and dates. The available options are On or Off .
Auto Reduction	When receiving a document as long as or longer than the paper loaded in the paper tray, the machine can reduce the size of the document to fit the size of paper loaded in the machine. Select On if you want to automatically reduce an incoming page. With this feature set to Off , the machine cannot reduce the document to fit onto one page, the document is divided and printed in actual size on two or more pages.
Discard Size	When receiving a document as long as longer than the paper installed in your machine, you can set the machine to discard any excess at the bottom of the page. If the received page is outside the margin you set, it will print on two sheets of paper at the actual size. When the document is within the margin and the Auto Reduction feature is turned on, the machine reduces the document to fit it onto the appropriate sized paper and discard does not occur. If the Auto Reduction feature is turned off or fails, the data within the margin will be discarded. Settings range from 0 to 30 mm.
Receive Code	The Receive Code allows you to initiate fax reception from an extension phone plugged into the EXT jack on the back of the machine. If you pick up the extension phone and hear fax tones, enter the Receive Code. The code is preset to *9* at the factory. Settings range from 0 to 9. See page 2.8.
DRPD Mode	You can receive a call using the Distinctive Ring Pattern Detection (DRPD) feature which enables a user to use a single telephone line to answer several different telephone numbers. In this menu, you can set the machine to recognize the ring patterns to answer. See page 2.8



2

BASIC FUNCTIONS

This chapter gives you basic information about using your machine as a fax machine and a copier.

This chapter includes:

- **Sending a Fax**
- **Receiving a Fax**
- **Making a Copy**
- **Automatic Dialing**

Sending a Fax

Preparing a Document

Using the ADF (Automatic Document Feeder), you can load up to 20 documents (47~90g/m², 12.5~24lb) for one job.

When you use the ADF:

- Do not load documents smaller than 142 x 148 mm or larger than 216 x 356 mm.
- Do not attempt to feed the following types of documents:
 - carbon-paper or carbon-backed paper
 - coated paper
 - onion skin or thin paper
 - wrinkled or creased paper
 - curled or rolled paper
 - torn paper
- Remove all staples and paper clips before loading documents.
- Make sure any glue, ink or correction fluid on the paper is completely dry before loading documents.
- Do not load documents containing different sizes or weights of paper.
- Do not load booklet, pamphlet, transparencies or documents having other unusual characteristics.

Loading a Document

- 1 Pull the document input support all the way out. Fold out the extender, if necessary.
- 2 Load the documents up to 20 pages **face down** into the ADF.

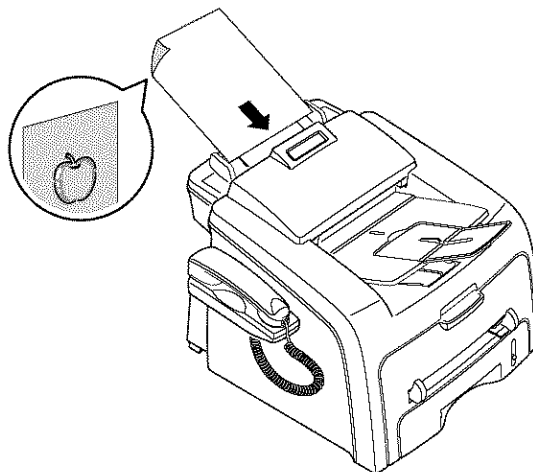

- 3 Adjust the document guides to the document size.

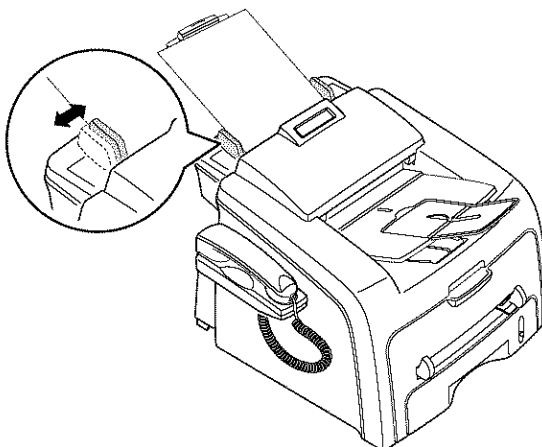

- 4 Adjust the document resolution, . See the following section.

Adjusting the Document Resolution

The default document settings produce good results when setting typical text based documents.

However, if you send documents that are of a poor quality, or contain photographs, you can adjust the resolution to produce a higher quality fax.

- 1 Press **Resolution**.
- 2 By pressing **Resolution** or the scroll button (◀ or ▶), you can choose from Standard, Fine, Super Fine and Photo.

The document types recommended for the resolution settings are described in the following table below:

Mode	Recommended for:
Standard	Documents with normal-sized characters.
Fine	Documents containing small characters or thin lines or documents printed using a dot-matrix printer.
Super Fine	Documents containing extremely fine detail. Super Fine mode is enabled only if the remote machine also supports the Super Fine resolution. See the notes below.
Photo	Documents containing shades of gray or photographs.



NOTES:

- For the memory transmission, Super Fine mode is not available. The resolution setting is automatically changed to Fine.
- When your machine is set to Super Fine resolution and the remote fax machine does not support the Super Fine resolution, the machine transmits using the highest resolution mode supported by the remote fax machine.

Sending a Fax Automatically

- 1 Load the document(s) face down into the ADF.
For details about loading a document, see page 2.2.
- 2 Adjust the document resolution to suit your fax needs. See page 2.3.
If you need to change the darkness, see page 1.20.
- 3 Enter the remote fax phone number using the number keypad.
You can use the one-touch keypad or speed or group dial numbers. For details about storing a number, see page 2.16.
- 4 Press **Start Copy/Fax**.
The number is dialed and then the machine begins sending the fax when the remote fax machine is ready.



NOTE: When you want to cancel the fax job, press **Stop/Clear** at any time while sending the fax.

Sending a Fax Manually

- 1 Load the document(s) face down into the ADF.
For details about loading a document, see page 2.2.
- 2 Adjust the document resolution to suit your fax needs. See page 2.3.
If you need to change the darkness, see page 1.20.
- 3 Press **On Hook Dial** or lift the handset. You hear a dial tone.
- 4 Enter the remote fax machine's fax number using the number keypad.
You can use the one-touch keypad or speed or group dial numbers. For details about storing a number, see page 2.16.
- 5 When you hear a high-pitched fax signal from the remote fax machine, press **Start Copy/Fax**.



NOTE: When you want to cancel the fax job, press **Stop/Clear** at any time while sending the fax.

Redialing the Last Number

To redial the number you last called:

Press **Redial/Pause**.

If a document is loaded in the ADF, the machine automatically begins to send.

Confirming Transmission

When the last page of your document has been sent successfully, the machine beeps and returns to Standby Mode.

When something goes wrong while sending your fax, an error message appears on the display. For a listing of error messages and their meanings, see page 6.6.

If you receive an error message, press **Stop/Clear** to clear the message and try to send the document again.

You can set your machine to print a confirmation report automatically each time sending a fax is completed. For further details, see the MSG Confirm item on page 1.20.

Automatic Redialing

When the number you have dialed is busy or there is no answer when you send a fax, the machine automatically redials the number every three minutes up to seven times by the factory default settings.

When the display shows "Retry Redial ?," press **Enter** to redial the number without waiting. To cancel the automatic redialing, press **Stop/Clear**.

To change the time interval between redials and the number of redial attempts. See page 1.20.

Receiving a Fax

About Receiving Modes

- In **Fax** mode, the machine answers an incoming fax call and immediately goes into the fax reception mode.
- In **Tel** mode, you can receive a fax by picking up the handset or pressing **On Hook Dial** (you can hear voice or fax tone from the remote machine) and then pressing **Start Copy/Fax** on the control panel of your machine. You can also pick up the handset of the extension phone and then press the remote receive code; see page 2.8.
- In **Ans/Fax** mode, the answering machine answers an incoming call, and the caller can leave a message on the answering machine. If the fax machine senses a fax tone on the line, the call automatically switches to Fax mode.
- In **DRPD** mode, you can receive a call using the Distinctive Ring Pattern Detection (DRPD) feature. "Distinctive Ring" is a telephone company service which enables a user to use a single telephone line to answer several different telephone numbers. For further details. See page 2.8

The current receiving mode displays when the machine is in Standby mode.

When the memory is full, the receiving mode automatically switches to Tel.



NOTES:

- To use Ans/Fax mode, attach an answering machine to the EXT jack on the back of your machine. See page 1.11.
- If you do not want other people to view your received documents, you can use Secure Receiving mode. In this mode, all of the received faxes are stored in the memory. For further details, see page 4.2.

Loading Paper for Receiving Faxes

Faxes can only be printed on Letter-, A4- or Legal-sized 20lb(75g/m²) plain paper. For details about loading paper and setting the paper size in the tray, see page 1.9 and page 1.16.

The paper level indicator on the front of the paper tray shows the amount of paper currently left in the tray. When the tray is empty, the indicator of the bar is lowered.

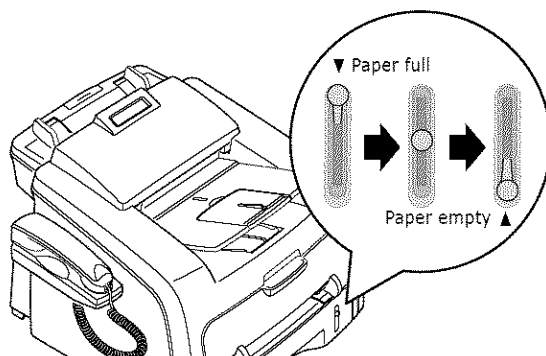

Receiving Automatically in Fax Mode

Your machine is preset to Fax mode at the factory. If you have changed the receiving mode, take the following steps to receive faxes automatically:

- 1 Press **Receive Mode**.
- 2 Press and hold **Receive Mode** until "Fax" displays on the bottom line.
You may have to repeat this action once or twice depending on the mode you're in.
- 3 When you receive a fax, the machine answers the call on a specified number of rings and automatically receives the fax.
To change the number of rings, see page 1.20.

Receiving Manually in Tel Mode

You can answer calls using the handset or the **On Hook Dial** button.

- 1 Press **Receive Mode**.
- 2 Press and hold **Receive Mode** until "Tel" displays on the bottom line.
You may have to repeat this action once or twice depending on the mode you're in.
- 3 When you receive a fax call, pick up the handset or press **On Hook Dial**.
You can hear a fax tone or voice from the remote machine.
- 4 Press **Start Copy/Fax** to receive the fax.
The machine begins receiving a fax and returns to Standby Mode when the reception is completed.

Receiving Automatically in Ans/Fax Mode

For using this mode, you must attach an answering machine to the EXT jack on the back of your machine. See page 1.11.

- 1 Press **Receive Mode**.
- 2 Press and hold **Receive Mode** until "Ans/Fax" displays on the bottom line.
You may have to repeat this action once or twice depending on the mode you're in.
- 3 When you receive a call, the answering machine answers.
If the caller leaves a message, the answering machine stores the message as it would normally. If your machine hears a fax tone on the line, it automatically starts to receive the fax.



NOTES:

- When you have set your machine to Ans/Fax mode and your answering machine is switched off or no answering machine is connected to the EXT jack, your machine automatically goes into Fax mode after a predefined number of rings.
 - If your answering machine has a “user-selectable ring counter,” set it to answer incoming calls within 1 ring.
 - If you are in Tel mode, which is receiving faxes manually, when the answering machine is connected to your machine, you must switch off the answering machine, or the outgoing message from the answering machine will interrupt your phone conversation.
-

Receiving Manually Using an Extension Telephone

You can receive a fax from someone you are talking to on the extension telephone without going to the fax machine.

When you receive a call on the extension phone and hear fax tones, press the keys ***9*** on the extension telephone. The machine receives the document.

Press the buttons slowly in sequence. If you still hear the fax tone from the remote machine, try pressing ***9*** once again.

9 is the remote receive code preset at the factory. The first and the last asterisks are fixed, but you can change the middle number to whatever you choose. For details about changing the code, see page 1.20.

Receiving Faxes Using the DRPD Mode

“Distinctive Ring” is a telephone company service which enables a user to use a single telephone line to answer several different telephone numbers. The particular number someone uses to call you on is identified by different ringing patterns, which consist of various combinations of long and short ringing sounds. This feature is often used by answering services who answer telephones for many different clients and need to know which number someone is calling in on to properly answer the phone.

Using the Distinctive Ring Pattern Detection feature, your fax machine can “learn” the ring pattern you designate to be answered by the FAX machine. Unless you change it, this ringing pattern will continue to be recognized and answered as a FAX call, and all other ringing patterns will be forwarded to the extension telephone or answering machine plugged into the EXT. jack. You can easily suspend or change Distinctive Ring Pattern Detection at any time.

Before using the Distinctive Ring Pattern Detection option, Distinctive Ring service must be installed on your telephone line by the telephone company. To set up Distinctive Ring Pattern Detection, you will need another telephone line at your location, or someone available to dial your FAX number from outside.

To set up the DRPD mode:

- 1 Press **Menu** until "Fax Setup" appears on the top line of the display.
The first available menu item, "Receive Mode," displays on the bottom line.
- 2 Press the scroll button (◀ or ▶) until you see "DRPD Mode" on the bottom line and press **Enter**.
- 3 When "Set" displays on the bottom line, press **Enter**.
The LCD displays "[Waiting Ring]."
- 4 Call your fax number from another telephone. It is not necessary to place the call from a fax machine.
- 5 When your machine begins to ring, do not answer the call. The machine requires several rings to learn the pattern.

When the machine completes learning, the LCD displays "End DRPD [Setup]".

If the DRPD setup fails, "DRPD Ring Error" appears. Press **Enter** when "DRPD Mode" displays and retry from Step 3.
- 6 To return to Standby Mode, press **Stop/Clear**.

When the DRPD feature is set up, the DRPD option is available in the Receive Mode menu. To receive faxes in the DRPD mode, you need to set the menu to **DRPD**.



NOTES:

- DRPD must be set up again if you re-assign your fax number, or connect the machine to another telephone line.
- After DRPD has been set up, call your fax number again to verify that the machine answers with a fax tone. Then have a call placed to a different number assigned to that same line to be sure the call is forwarded to the extension telephone or answering machine plugged into the EXT. jack.:

Receiving Faxes in the Memory

Your machine can receive faxes while you are making copies or printing a received fax. If you receive a fax while you are copying, your machine stores incoming faxes in the memory. Then, as soon as you finish copying, the machine automatically prints the fax.

Making a Copy

Loading Paper for Copying

The instructions for loading print materials into the paper tray are the same whether you are faxing or copying. For further details, see page 1.9 for loading in the paper tray.

For copying, you can also use the manual feeder to load special print material, such as transparencies or labels, if they are Letter-, A4-, Legal-sized. For further details about print materials you can use, see page A.5.

To load paper in the manual feeder:

- 1 Load a sheet of the print material with the print side face up and into the center of the tray.

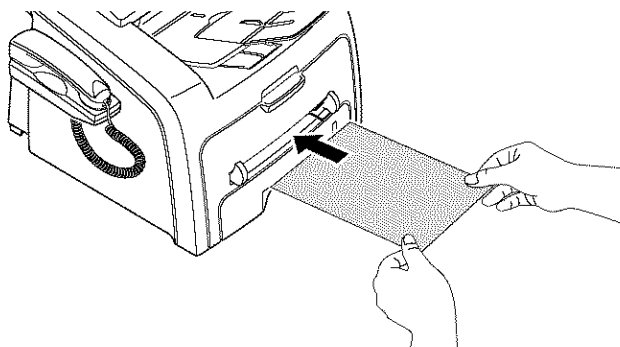

For transparencies, hold them by the edges and avoid touching the print side. Oils from your fingers can cause print quality problems.

- 2 Adjust the guide to the width of the print material.

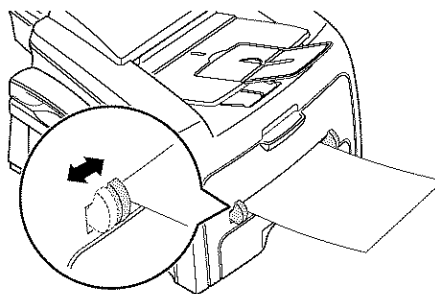

NOTE: When printing on previously printed paper from the manual feeder, the printed side should be facing down with an uncurled edge to the machine. If you experience problems with paper feed, turn the paper around.

- 3 Open the rear cover to use the rear output slot.

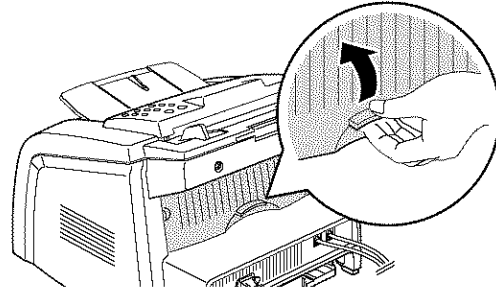

CAUTION:

- The fusing area inside the rear part of your machine becomes hot once the machine is turned on. Be careful when you access this area.

- 4 After copying, close the rear cover.

Setting the Paper Type and Size for the Manual Feeder

After loading paper in the manual feeder, you need to set the correct paper type and size using the control panel buttons.

To set the paper size for the manual feeder:

- 1 Press **Menu**.

The display shows "Paper Setting" on the top line and the first item, "Paper Type," on the bottom line.

- 2 Press **Enter** to access the menu item.
- 3 Use the scroll button (◀ or ▶) to find the paper type you are using and press **Enter** to save it.
- 4 Press the ▶ button to scroll to "Paper Size" and press **Enter** to access the menu item.



NOTE: If you are using envelopes or card stocks, you don't need to set the paper size.

- 5 Use the scroll button (◀ or ▶) to display "Manual Feed" on the bottom line. Press **Enter** to access the menu item.
- 6 Use the scroll button (◀ or ▶) to find the paper size you are using and press **Enter** to save it.
- 7 To return to Standby mode, press **Stop/Clear**.

Making a Copy

- 1 Load the documents up to 20 pages **face down** into the ADF and adjust the document guides to the document size.
See page 2.2 for further details about preparing a document and loading it into the ADF.
- 2 Customize the copy settings including number of copies, copy size, darkness and original type by using the control panel buttons. See the following section. Sorts the copy job. For example, if you make 2 copies of 3 page documents, one complete 3 page document will print followed by the second complete document. see page 2.15
To clear the settings, use the **Stop/Clear** button.
- 3 Press **Start Copy/Fax**.

Setting Copy Options

The buttons on the control panel let you make all the basic copy options; darkness, document type, copy size and number of copies. Set the following options for the current copy job before pressing **Start Copy/Fax** to make copies.



NOTE: If you press **Stop/Clear** while you set the copy options, all of the options you have set for the current copy job will be canceled and return to their default status. Or, they will automatically return to their default status after the machine completes the copy.

Darkness

If you have an original document containing faint markings and dark images, you can adjust the brightness to make a copy that is easier to read.

To adjust the contrast, press **Darkness**. Each time you press the button, the LED labeled with the selected mode turns on.

You can choose from the following contrast modes:

- **Light:** works well with dark print.
- **Normal:** works well with standard typed or printed documents.
- **Dark:** works well with light print or faint pencil markings.

Original Type

The Original Type setting is used to improve the copy quality by selecting the document for the current copy job.

To select the document type, press **Original Type**. Each time you press the button, the LED labeled with the selected mode turns on.

You can choose from the following image modes:

- **Text:** Use for documents containing mostly text.
- **Photo:** Use when the originals are photographs.



NOTE: When you copy a document containing color on the background, such as a newspaper or a catalog, you can get the background on your copy. If you want to reduce the background, change the **Darkness** setting to **Light** and/or the **Original Type** setting to **Text**.

Number of Copies

Using the **No. of Copies** button, you can select the number of copies from 1 to 99.

- 1 Press **No. of Copies**.
- 2 Press the scroll button (◀ or ▶) until the number you want appears on the display.

Pressing and holding the buttons allows you to quickly increase and decreases in increments of 5.

You can enter the value using the number keypad.

- 3 Press **Enter** to save the selection.

Reduced/Enlarged Copying

Using the **Reduce/Enlarge** button, you can reduce or enlarge the size of a copied image from 50% to 150%.

To select from the predefined copy sizes:

- 1 Press **Reduce/Enlarge**.
The default setting appears on the bottom line of the display.
- 2 Use **Reduce/Enlarge** or the scroll button (◀ or ▶) to find the size setting you want.
- 3 Press **Enter** to save the selection.

To fine-tune the size of copies:

- 1 Press **Reduce/Enlarge**.
- 2 Press **Reduce/Enlarge** or the scroll button (◀ or ▶) until "Custom:50-150%" displays on the bottom line. Press **Enter**.
- 3 Press the scroll button (◀ or ▶) until the copy size you want appears on the display.

Pressing and holding the buttons allows you to quickly increase and decreases in increments of 5.

You can enter the value using the number keypad.

- 4 Press **Enter** to save the selection.



NOTE: When you make a reduced copy, black lines may appear at the bottom of your copy.

Changing the Default Settings

Copy options, including darkness, original type, copy size and number of copies, can be set to the most frequently used modes. When you copy a document, the default settings are used unless they are changed by using the corresponding buttons on the control panel.

To create your own default settings:

- 1 Press **Menu** on the control panel until "Copy Setup" appears on the top line of the display.
The first menu item, "Default-Change," appears on the bottom line.
- 2 Press **Enter** to access the menu item. The first setup option, "Darkness," appears on the bottom line.
- 3 Press the scroll button (◀ or ▶) to scroll through the setup options.
- 4 When the option you want to set appears, press **Enter** to access the option.
- 5 Change the setting using the scroll button (◀ or ▶) or enter the value using the number keypad.
- 6 Press **Enter** to save the selection.
- 7 Repeat steps 3 through 6, as needed.
- 8 To return to Standby mode, press **Stop/Clear**.



NOTE: While you set copy options, pressing **Stop/Clear** cancels the changed settings and restores their default status.

Setting the Time Out Option

You can set the time the machine waits before it restores the default copy settings, if you do not start copying after changing them on the control panel.

- 1 Press **Menu** on the control panel until "Copy Setup" appears on the top line of the display.
- 2 Press the scroll button (◀ or ▶) to display "Timeout" on the bottom line.
- 3 Press **Enter** to access the menu item.
- 4 Press the scroll button (◀ or ▶) until the status you want appears on the display.
You can select from 15, 30, 60 and 180 (seconds). Selecting "Off" means that the machine does not restore the default settings until you press **Start Copy/Fax** to start copying, or **Stop/Clear** to cancel.
- 5 Press **Enter** to save the selection.
- 6 To return to Standby mode, press **Stop/Clear**.

Collation Copying

The Collation copying feature is available only when you load documents in the ADF.

- 1 Press **Menu** on the control panel until "Copy Setup" appears on the top line of the display.
- 2 Press the scroll button (◀ or ▶) to display "Copy Collated" on the bottom line.
- 3 Press **Enter** to access the menu item.
- 4 If you are making multiple copies and want to collate them, press the scroll button (◀ or ▶) to set Collated Copy to "On" and press **Enter**.

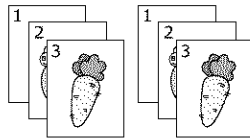

▲ Collated Copy On

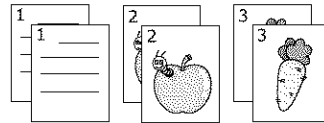

▲ Collated Copy Off

- 5 Press **Start Copy/Fax** to begin copying.

Automatic Dialing

One-touch Dialing

The 20 one-touch buttons on the control panel lets you store frequently-used fax numbers and dial a number automatically with a touch of a button.

Storing a Number for One-touch Dialing

- 1 Press and hold one of the one-touch dial buttons for about 2 seconds.

The display asks you to enter the fax number. "T" signifies that you are assigning a one-touch dial button.

If a number is already stored in the location you chose, the display shows the number to allow you to change it. To start over with another one-touch button, press **Stop/Clear**.

- 2 Enter the number you want to store using the number keypad and press **Enter**.

To insert a pause between numbers, press **Redial/Pause**. A "-" appears on the display.

If you make a mistake while entering a number, press the ◀ button and re-enter the correct number.

- 3 To assign a name to the number, enter the name you want. For details about entering characters, see page 1.14.

If you do not want to assign a name, skip this step.

- 4 Press **Enter** when the name appears correctly or without entering a name.

- 5 To store more numbers, press a one-touch button and repeat steps 2 through 4.

To return to Standby mode, press **Stop/Clear**.

Sending a Fax using a One-touch Number

- 1 Load the document(s) face down into the ADF.

For details about loading a document, see page 2.2.

- 2 Adjust the document resolution to suit your fax needs. See page 2.3.

If you need to change the darkness, see page 1.20.

- 3 Press the one-touch button where you stored a number.

The document scans into the memory.

- 4 The machine dials the fax number stored in the one-touch dial location and the document is sent when the remote fax machine answers.

Speed Dialing

You can store up to 80 frequently dialed numbers in one or two-digit speed dial locations (0-79).

Storing a Number for Speed Dialing

- 1 Press **Phone Book** on the control panel.
- 2 Press **Phone Book** or the scroll button (◀ or ▶) to display "Store&Edit" on the bottom line of the display. Press **Enter**.
- 3 Press **Enter** when "Speed Dials" appears on the display.
The display prompts you to enter a location number, showing the first available number.
- 4 Enter a one or two-digit speed dial number between 0 and 79, using the number keypad or scroll button (◀ or ▶), and press **Enter**.
If a number is already stored in the location you chose, the display shows the number to allow you to change it. To start over with another speed-dial number, press **Upper Level**.
- 5 Enter the number you want to store using the number keypad and press **Enter**.
To insert a pause between numbers, press **Redial/Pause**. A "-" appears on the display.
- 6 To assign a name to the number, enter the name you want. For details about entering characters, see page 1.14.
If you do not want to assign a name, skip this step.
- 7 Press **Enter** when the name appears correctly or without entering a name.
- 8 To store more fax numbers, repeat steps 4 through 7.
To return to Standby mode, press **Stop/Clear**.

Sending a Fax using a Speed Number

- 1 Feed the document(s) face up into the ADF.
For details about loading a document, see page 2.2.
- 2 Adjust the document resolution to suit your fax needs. See page 2.3.
If you need to change the darkness, see page 1.20.
- 3 Enter the speed dial number.
 - For a one-digit speed dial number, press and hold the appropriate digit button.
 - For a two-digit speed dial number, press the first digit button and hold the last digit button.The corresponding entry's name briefly displays.
- 4 The document scans into the memory.
The fax number stored in the speed dial location is automatically dialed. The document is sent when the remote fax machine answers.

Group Dialing

If you frequently send the same document to several destinations, you can create a group of these destinations and set them under a one or two-digit group dial location. This enables you to use a group dial number setting to send the same document to all the destinations in the group.

Setting a Group Dial Number

- 1 Press **Phone Book** on the control panel.
- 2 Press **Phone Book** or the scroll button (◀ or ▶) to display "Store&Edit" on the bottom line of the display. Press **Enter**.
- 3 Press the scroll button (◀ or ▶) to display "Group Dials" on the bottom line and press **Enter**.
- 4 Press **Enter** when "New" displays on the bottom line.
The display prompts you to enter a location number, showing the first available number.
- 5 Enter a group number between 0 and 79, using the number keypad or scroll button (◀ or ▶), and press **Enter**.
- 6 Press a one-touch dial button, or enter a one or two-digit speed number you want to include in the group and press **Enter**.
- 7 When the display confirms the number to be added to the number, press **Enter**.
- 8 Repeat steps 6 and 7 to enter other one-touch or speed dial numbers into the group.
- 9 Press **Upper Level** when you have entered all of the numbers. The display prompts you to enter a group ID.
- 10 To assign a name to the group, enter the name.
OR
If you do not want to assign a name, skip this step.
- 11 Press **Enter** when the name appears correctly or without entering a name.
- 12 If you want to assign another group, press **Enter** and repeat from step 5.
OR
To return to Standby mode, press **Stop/Clear**.



NOTE: You cannot include one group dial number in another group dial number.

Editing Group Dial Numbers

You can delete a specific speed dial number from a selected group or add a new number to the selected group.

- 1 Press **Phone Book** on the control panel.
- 2 Press **Phone Book** or the scroll button (◀ or ▶) to display "Store&Edit" on the bottom line of the display. Press **Enter**.
- 3 Press the scroll button (◀ or ▶) to display "Group Dials" on the bottom line and press **Enter**.
- 4 Press the scroll button (◀ or ▶) to display "Edit" on the bottom line and press **Enter**.
- 5 Enter the group number you want to edit and press **Enter**.
- 6 Press a one-touch dial button to enter a speed dial number you want to add or delete.
- 7 When you enter the specific number in the group, the display shows "Delete?."
When you enter a new number, the display shows "Add?."
- 8 Press **Enter** to add or delete the number.
- 9 Change the name, if necessary, and press **Upper Level**.
- 10 If you want to edit another group, press **Enter** and repeat from step 5.

OR

To return to Standby mode, press **Stop/Clear**.

Sending a Fax Using Group Dialing (Multi-address Transmission)

You can use group dialing for Broadcasting or Delayed transmissions.

Follow the procedure of the operation (Broadcasting transmission; see page 3.2, Delayed transmission; see page 3.2). When you come to a step in which the display asks you to enter the remote fax number:

- For a one-digit group number, press and hold the appropriate digit button.
- For a two-digit group number, press the first digit button and hold the last digit button.

You can use only one group number for one operation. Then continue the procedure to complete the operation.

Your machine automatically scans the document loaded in the ADF and then dials each of the numbers included in the group.

Searching for a Number in the Memory

There are two ways to search for a number in the memory. You can either scan from A to Z sequentially, or you can search using the first letter of the name associated with the number.

Searching Sequentially through the Memory

- 1 Press **Phone Book**.
- 2 Press **Enter** when "Search&Dial" appears on the display.
- 3 Press the scroll button (◀ or ▶) to scroll through the memory until the name and number you want to dial display. You can search upwards or downwards through the entire memory in alphabetical order, from A to Z.

While searching through the machine's memory, you can see that each entry is preceded by one of three letters; "T" for one-touch dial, "S" for speed dial or "G" for group dial number. These letters tell you how the number is stored.

- 4 When the name and/or the number you want displays, press **Start Copy/Fax** or **Enter** to dial.

Searching with a Particular First Letter

- 1 Press **Phone Book**.
- 2 Press **Enter** when "Search&Dial" appears on the display.
- 3 Press the button labeled with the letter you want to search for. A name beginning with the letter displays.

For example, if you want to find the name "MOBILE," press the **6** button, which is labeled with "MNO."

- 4 Press the scroll button (◀ or ▶) to display the next name.
- 5 When the name and/or the number you want displays, press **Start Copy/Fax** or **Enter** to dial.

Printing a Phonebook List

You can check your automatic dial setting by printing a Phonebook list.

- 1 Press **Phone Book**.
- 2 Press **Phone Book** or the scroll button (◀ or ▶) until "Print" appears on the bottom line and press **Enter**.

A list showing your one-touch dial, speed dial and group dial entries prints out.



3

ADVANCED FAX FUNCTIONS

This chapter includes:

- **Sending Broadcasting Faxes**
- **Sending a Delayed Fax**
- **Sending a Priority Fax**
- **Polling a Remote Machine**
- **Adding Documents to a Scheduled Fax**
- **Canceling a Scheduled Fax**

Sending Broadcasting Faxes

Using the **Broadcasting** button on the control panel, you can use the broadcasting fax feature, which allows you to send a document to multiple locations. Documents are automatically stored in the memory and sent to a remote station. After transmission, the documents are automatically erased from the memory.

- 1 Load the document(s) face down into the ADF.
For details about loading a document, see page 2.2.
- 2 Adjust the document resolution to suit your fax needs. See page 2.3.
If you need to change the darkness, see page 1.20.
- 3 Press **Broadcasting** on the control panel.
- 4 Enter the number of the remote machine using the number keypad.
You can use one-touch keypad or speed dial or group dial numbers. For details about storing a number, see page 2.16.
- 5 Press **Enter** to confirm the number. The display asks you to enter another fax number to send the document.



NOTE: The "Another No." prompt does not appear if you have added numbers for another broadcasting or delayed fax job. You must wait until the job is completed.

- 6 To enter more fax numbers, press **1** to select "Yes" and repeat steps 4 and 5. You can add up to 10 destinations.
Note that you cannot use group dial numbers for another fax number.
- 7 When you finish entering fax numbers, press **2** to select "No" at a "Another No." prompt.
The document is scanned into the memory before transmission. The display shows the memory capacity and the number of pages being stored in the memory.
The machine begins sending the document in order of the numbers you entered.

Sending a Delayed Fax

You can set your machine to send a fax at a later time when you will not be present.

- 1 Load the document(s) face down into the ADF.
For details about loading a document, see page 2.2.
- 2 Adjust the document resolution to suit your fax needs. See page 2.3.
If you need to change the darkness, see page 1.20.

- 3 Press **Menu** until "Fax Feature" appears on the top line of the display. The first available menu item, "DelayFax," displays on the bottom line.
- 4 Press **Enter**.
- 5 Enter the number of the remote machine using the number keypad.
You can use one-touch keypad or speed dial or group dial numbers. For details about storing a number, see page 2.16.
- 6 Press **Enter** to confirm the number on the display. The display asks you to enter another fax number to send the document.



NOTE: The "Another No." prompt does not appear if you have added numbers for another broadcasting or delayed fax job. You must wait until the job is completed.

- 7 To enter more fax numbers, press **1** to select "Yes" and repeat steps 4 and 5. You can add up to 10 destinations.
Note that you cannot use group dial numbers for another fax number.
- 8 When you finish entering fax numbers, press **2** to select "No" at a "Another No." prompt.
The display asks you to enter a name.
- 9 To assign a name to the transmission, enter the name. If not, skip this step.
For details on how to enter the name using the number keypad, see page 1.14.
- 10 Press **Enter**.
The display shows the current time and asks you to enter the starting time when the fax is to be sent.
- 11 Enter the time using the number keypad.
To select "AM" or "PM" for 12-hour format, press the * or # button or any number button.
If you set a time earlier than the current time, the document will be sent at that time on the following day.
- 12 Press **Enter** when the start time displays correctly.
The document is scanned into the memory before transmission. The display shows the memory capacity and the number of pages being stored in the memory.
The machine returns to Standby mode. The display reminds you that you are in Standby mode and that a delayed fax is set.



NOTE: If you want to cancel the delayed transmission, see "Canceling a Scheduled Fax" on page 3.6.

Sending a Priority Fax

Using the Priority Fax feature, a high priority document can be sent ahead of reserved operations. The document is scanned into the memory and transmitted when the current operation is finished. In addition, the priority transmission interrupts a broadcast operation between stations (i.e., when the transmission to station A ends, before transmission to station B begins) or between redial attempts.

- 1 Load the document(s) face down into the ADF.
For details about loading a document, see page 2.2.
- 2 Adjust the document resolution to suit your fax needs. See page 2.3.
If you need to change the darkness, see page 1.20.
- 3 Press **Menu** until "Fax Feature" appears on the top line of the display.
- 4 Press the scroll button (◀ or ▶) to display "Priority Fax" on the bottom line and press **Enter**.
- 5 Enter the number of the remote machine using the number keypad.
To enter the number, you can use one-touch keypad or speed dial or group dial numbers. For details, see page 2.16.
- 6 Press **Enter** to confirm the number. The display asks you to enter a name.
- 7 To assign a name to the transmission, enter the name. If not, skip this step.
For details on how to enter a name using the number keypad, see page 1.14.
- 8 Press **Enter**.
The document is scanned into the memory before transmission. The display shows the memory capacity and the number of pages being stored in the memory.
The machine shows the number being dialed and begins sending the document.

Polling a Remote Machine

Polling is used when one fax machine requests another to send a document. This is useful when the person with the original document to be sent is not in the office. The person who wants to receive the document calls the machine holding it and requests that the document be sent. In other words, it "polls" the machine holding the original document.

You can set the machine to automatically receive documents from the unattended remote fax machine at any time. This feature permits unattended polling in the evening hours when telephone rates are lower.



NOTE: The machine must be ready for polling.

- 1 Press **Menu** until "Fax Feature" appears on the top line of the display.
- 2 Press the scroll button (◀ or ▶) to display "Delay RX Poll" on the bottom line and press **Enter**.
- 3 Enter the number of the remote machine to be polled using the number keypad.
To enter the number, you can use a one-touch keypad or speed dial number. For details, see page 2.16.
- 4 Press **Enter** to confirm the number on the display. The display asks you to enter another fax number.



NOTE: The "Another No." prompt does not appear if you have added numbers for another broadcasting or delayed fax job. You must wait until the job is completed.

- 5 To enter more fax numbers, press **1** to select "Yes" and repeat steps 4 and 5. You can add up to 10 destinations.
Note that you cannot use group dial numbers for another fax number.
- 6 When you finish entering fax numbers, press **2** to select "No" at a "Another No." prompt.
- 7 Enter the time using the number keypad.
To select "AM" or "PM" for 12-hour format, press the * or # button or any number button.
If you set a time earlier than the current time, your machine will poll at that time on the following day.
- 8 When the remote machine is secured with a 4-digit poll code, enter the correct code and press **Enter**.
If not, press **Enter** to accept "0000" which represents no code, or enter **0000**.
- 9 Press **Enter** when the start time displays correctly.
At the specified time, the machine will dial the numbers and receive documents from the remote machine in the order you entered.

Adding Documents to a Scheduled Fax

You can add documents to the delayed transmission previously reserved in your machine's memory.

- 1 Load the document(s) face down into the ADF.
For details about loading a document, see page 2.2.
- 2 Adjust the document resolution to suit your fax needs. See page 2.3.
If you need to change the darkness, see page 1.20.
- 3 Press **Menu** until "Fax Feature" appears on the top line of the display.
- 4 Press the scroll button (◀ or ▶) to display "Add Page" on the bottom line and press **Enter**. The display shows the last job reserved in the memory.
- 5 Press the scroll button (◀ or ▶) until you see the fax job to which you want to add documents and press **Enter**.

The machine automatically stores the documents in the memory, and the display shows the memory capacity and the number of pages.

After storing, the machine displays the numbers of total pages and added pages and then returns to Standby mode.

Canceling a Scheduled Fax

- 1 Press **Menu** until "Fax Feature" appears on the top line of the display.
- 2 Press the scroll button (◀ or ▶) to display "Cancel Job" and press **Enter**. The display shows the last job reserved in the memory.
- 3 Press the scroll button (◀ or ▶) until you see the fax job you want to cancel and press **Enter**.
- 4 When the display confirms your selection, press **1** to select "Yes." The selected job is canceled and the machine returns to Standby mode.

To cancel your selection, press **2** to select "No."



4

ADDITIONAL FEATURES

This chapter includes:

- **Using Secure Receiving Mode**
- **Printing Reports**
- **Using Advanced Fax Settings**

Using Secure Receiving Mode

You may need to prevent your received faxes from being accessed by unauthorized people. You can turn on Secure Receiving mode to restrict printing out all of the received faxes when the machine is unattended. In Secure Receiving mode, all of the incoming faxes go into the memory. When the mode turns off, any faxes stored are printed.

To turn Secure Receiving mode on:

- 1 Press **Menu** until "Advanced Fax" appears on the top line of the display.
- 2 Press the scroll button (◀ or ▶) until "Secure Receive" appears on the bottom line and press **Enter**.
- 3 Press the scroll button (◀ or ▶) to display "On" on the bottom line and press **Enter**.
- 4 Enter a four-digit passcode you want to use and press **Enter**.



NOTE: You can activate Secure Receiving mode without setting a passcode, but cannot protect your faxes.

- 5 Re-enter the passcode to confirm it and press **Enter**.
- 6 To return to Standby mode, press **Stop/Clear**.

When a fax is received in Secure Receiving mode, your machine stores it into the memory and displays "Secure Receive" to let you know that there is a fax stored.

To print received documents:

- 1 Press **Menu** until "Advanced Fax" appears on the top line of the display.
- 2 Press the scroll button (◀ or ▶) until "Secure Receive" appears on the bottom line and press **Enter**.
- 3 Press the scroll button (◀ or ▶) to display "Print" on the bottom line and press **Enter**.
- 4 Enter the four-digit passcode and press **Enter**.

The machine prints all of the faxes stored in the memory.

To turn Secure Receiving mode off:

- 1 Press **Menu** until "Advanced Fax" appears on the top line of the display.
- 2 Press the scroll button (◀ or ▶) until "Secure Receive" appears on the bottom line and press **Enter**.
- 3 Press the scroll button (◀ or ▶) to display "Off" on the bottom line and press **Enter**.
- 4 Enter the four-digit passcode and press **Enter**.

The mode is deactivated and the machine prints all of the faxes stored in the memory.

- 5 To return to Standby mode, press **Stop/Clear**.

Printing Reports

Your machine can print reports containing useful information. The following reports are available:

Phonebook List

This list shows all of the numbers currently stored in the machine's memory as speed dial and group dial numbers.

You can print this Phonebook list using the **Phone Book** button; see page 2.20.

Sent Fax Report

This report shows information of the faxes you recently sent.

Received Fax Report

This report shows information of the faxes you recently received.

System Data List

This list shows the status of the user-selectable options. You may print this list to confirm your changes after changing any settings.

Scheduled Job Information

This list shows the document currently stored for Delayed faxes or Toll Save faxes. The list shows the starting time and type of operation.

Message Confirmation

This report shows the fax number, the number of pages, the elapsed time of the job, the communication mode, and the communication results.

You can set up your machine to automatically print the message confirmation report after each fax job. See page 1.20.

Junk Fax Number List

This list shows up to 10 fax numbers specified as the junk fax numbers by using the **Junk Fax Setup** menu; see page 4.5. When the Junk Fax Barrier feature is turned on, incoming faxes from those numbers are blocked.

This feature recognize the last 6 digits of the fax number set as a remote fax machine's ID.

Multi-communication Report

This report is printed automatically after sending documents from more than one location.

Power Failure Report

This report is printed out automatically when power is restored after a power failure, if there occurs any data loss due to the power failure.



NOTE: The lists you have set to print out automatically don't print out when there is no paper loaded or a paper jam has occurred.

Printing a Report

- 1 Press **Menu** until "Reports" appears on the top line of the display. The first available menu item, "Phone Book" displays on the bottom line.
- 2 Press the scroll button (◀ or ▶) to display the report or list you want to print on the bottom line.
 - Phone Book: Phonebook list
 - Sent Report: Sent fax report
 - RCV Report: Received fax report
 - System Data: System data list
 - Scheduled Jobs: Scheduled job information
 - MSG Confirm: Message confirmation
 - Junk Fax List: Junk fax number list
- 3 Press **Enter**. The selected information prints out.

Using Advanced Fax Settings

Your machine has various user-selectable setting options for sending or receiving faxes. These options are preset at the factory, but you may need to change them. To find out how the options are currently set, print the System Data list. For details about printing the list, page 4.3

Changing Setting Options

- 1 Press **Menu** until "Advanced Fax" appears on the top line of the display. The first available menu item, "Send Forward," displays on the bottom line.
- 2 Press the scroll button (◀ or ▶) until you see the desired menu item on the bottom line and press **Enter**.
- 3 When the option you want appears on the display, choose a status by pressing the scroll button (◀ or ▶) or enter a value using the number keypad.
- 4 Press **Enter** to save the selection.
- 5 You can exit from Setup mode at any time by pressing **Stop/Clear**.

Advanced Fax Setting Options

Option	Description
Send Forward	You can set the machine to always forward all of the outgoing faxes to a specified destination, in addition to the fax numbers you entered. Select Off to turn this feature off. Select On to turn this feature on. You can set the number of the remote fax machine to which faxes are forwarded.

Option	Description
RCV Forward	<p>You can set your machine to forward incoming faxes to another fax number during a specified period of time. When a fax arrives at your machine, it is stored in the memory. Then, the machine dials the fax number that you have specified and sends the fax.</p> <p>Select Off to turn this feature off. Select On to turn this feature on. You can set the fax number to which faxes are forwarded. Then, you can enter the starting time and/or the ending time. The Print Local Copy option allows you to set the machine to print the fax, if fax forwarding is completed without any error.</p>
Toll Save	<p>You can set your machine to store your faxes into the memory and send them at the specified toll-saving time. For details about Toll Save mode, see page 1.18.</p> <p>Select Off to turn this feature off. Select On to turn this feature on. You can set the starting time and/or the ending time for Toll Save mode.</p>
Junk Fax Setup	<p>Using the Junk Fax Barrier feature, the system will not accept faxes sent from remote stations of which their numbers are stored in the memory as junk fax numbers. This feature is useful for blocking any unwanted faxes.</p> <p>Select Off to turn the feature off. Anybody can send you a fax. Select On to turn the feature on. You can set up to 10 fax numbers as junk fax numbers using the Set option. This feature recognize the last 6 digits of the fax number set as a remote fax machine's ID. After storing numbers, you do not receive any faxes from the registered stations. To delete all the junk fax numbers, use the All Delete option.</p>
Secure Receive	<p>You can keep your received faxes from being accessed by unauthorized people.</p> <p>For further details about setting this mode, see page 4.2.</p>
Prefix Dial No.	<p>You can set a prefix dial number of up to five digits. This number dials before any automatic dial number is started. It is useful for accessing the PABX exchange.</p>
Stamp RCV Name	<p>This option allows the machine to automatically print the page number, and the date and time of the reception at the bottom of each page of a received document.</p> <p>Select Off to turn this feature off. Select On to turn this feature on.</p>
ECM Mode (Error Correction Mode)	<p>Error Correction Mode helps with poor line quality and makes sure any fax you send are sent smoothly to any other ECM-equipped fax machine. If the line quality is poor, it takes more time to send a fax when you are using the ECM.</p> <p>Select Off to turn this feature off. Select On to turn this feature on.</p>

MEMO



5

MAINTENANCE

This chapter provides information for maintaining your machine and the toner cartridge.

This chapter includes:

- **Clearing the Memory**
- **Adjusting Shading**
- **Cleaning Your Machine**
- **Maintaining the Toner Cartridge**
- **Consumables and Replacement Parts**
- **Replacing the ADF Rubber Pad**

Clearing the Memory

You can selectively clear information stored in your machine's memory.

- 1 Press **Menu** on the control panel until "Maintenance" appears on the top line of the display.
- 2 Press the scroll button (◀ or ▶) until you see "Clear Memory" on the bottom line and press **Enter**.

The first available menu item, "Clear All Mem." displays on the bottom line.

- 3 Press the scroll button (◀ or ▶) until you see the item you want to clear.
 - Clear All Mem.: Clears all of the data stored in the memory and resets all of your settings to the factory default.
 - Paper Setting: Restores all of the Paper Setting options to the factory default.
 - Copy Setup: Restores all of the Copy Setup options to the factory default.
 - Fax Setup: Restores all of the Fax Setup options to the factory default.
 - Fax Feature: Cancels all of the scheduled fax jobs in the machine's memory.
 - Advanced Fax: Restores all of the Advanced Fax setting options to the factory default.
 - Sound/Volume: Resets the sound and volume settings to the factory default.
 - Machine Setup: Resets all of the system settings, such as the machine ID, date and time, display language and save modes, to the factory default.
 - Sent Report: Clears all of records of your faxes sent.
 - RCV Report: Clears all of records of your faxes received.
 - Phone Book: Clears the one-touch, speed and group dial numbers stored in the memory.
- 4 Press **Enter**. The selected memory is cleared and the display asks you to continue clearing the next item.
- 5 To clear another item, press **Enter** and repeat steps 3 and 4
OR
To return to Standby mode, press **Stop/Clear**.

Adjusting Shading

When the scan unit becomes dirty, it can alter the shading value. If your copy has black lines or is blurred, adjust the shading setting.

- 1 Load a sheet of white paper into the ADF.
- 2 Press **Menu** on the control panel until "Maintenance" appears on the top line of the display.
- 3 Press the scroll button (◀ or ▶) until "Adjust Shading" appears on the bottom line and press **Enter**.
- 4 Press the scroll button (◀ or ▶) to select "On" and press **Enter**.
Your machine picks up the paper and adjusts the shading value.

Cleaning Your Machine

To maintain the print quality, follow the cleaning procedures below each time the toner cartridge is replaced or if print quality problems occur.



NOTE: While cleaning the inside of the machine, be careful not to touch the transfer roller, located underneath the toner cartridge. Oil from your fingers can cause print quality problems.



CAUTIONS: Cleaning the cabinet of the machine with surfactants containing large amounts of alcohol, solvent or other strong substances can discolor or crack the cabinet.

Cleaning the Outside

Clean the cabinet of the machine with a soft lint-free cloth. You can dampen the cloth slightly with water, but be careful not to let any water drip onto the machine or inside of it.

Cleaning the Inside

During the printing process, paper, toner and dust particles can accumulate inside the machine. This buildup can cause print quality problems, such as toner specks or smearing. Cleaning the inside of the machine clears or reduces these problems.

- 1 Turn the machine off and unplug the power cord. Wait for the machine to cool down.
- 2 Open the front cover and pull the toner cartridge out, lightly pushing it down.

- 3 With a dry lint-free cloth, wipe away any dust and spilled toner from the toner cartridge area and the toner cartridge cavity.

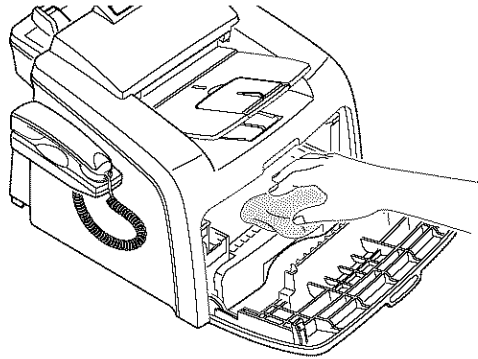

CAUTION: To prevent damage to the toner cartridge, do not expose it to light for more than a few minute. Cover it with a piece of paper, if necessary. Do not touch the black transfer roller inside the machine.

- 4 Reinsert the toner cartridge and close the cover.
- 5 Plug in the power cord and turn the machine on.

Cleaning the Scan Unit

Keeping the scan unit clean helps ensure the best possible copies. We suggest that you clean the scan unit at the start of each day and during the day, as needed.

- 1 Slightly dampen a soft lint-free cloth or paper towel with water.
- 2 Open the control panel by gripping its bottom and pulling it upward.

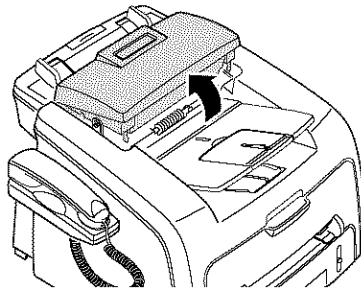

- 3** Disassemble the white roller as follows:

The right end of the white roller has a plastic bushing that is snapped shut with small tab on it. Pull the bushing slightly inward, then rotate the bushing until it reach a slot (1). Then pull the roller upward (2).

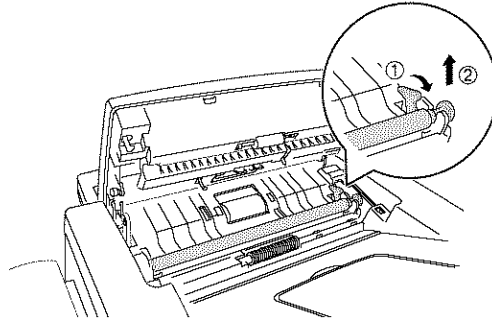

- 4** Wipe the roller surface with a soft cloth dampened with water.

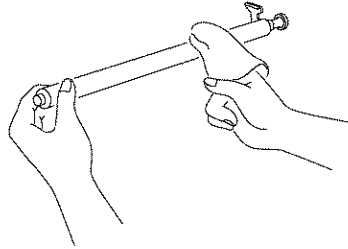

- 5** Carefully wipe the scanning glass with a soft dry cloth.

If the glass is very dirty, first wipe it with a slightly dampened cloth, and then with a dry cloth. Be very careful not to scratch the glass surface.

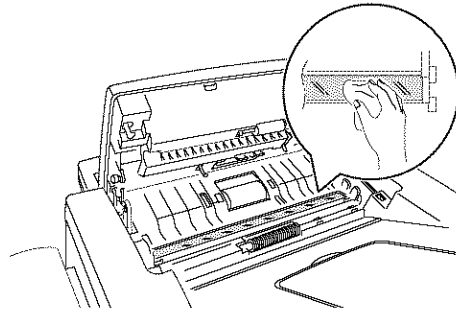

- 6** Replace the roller by inserting the left end first followed by the right end, then rotating the bushing until it locks into place.
- 7** Reconnect the support and the control panel, then close the control panel firmly until it clicks into place.

Maintaining the Toner Cartridge

Toner Cartridge Storage

To get the most from the toner cartridge, keep the following guidelines in mind:

- Do not remove the toner cartridge from its package until ready for use.
- Do not refill the toner cartridge. **The machine warranty does not cover damage caused by using a refilled cartridge.**
- Store toner cartridges in the same environment as your machine.
- To prevent damage to the toner cartridge, do not expose it to light for more than a few minute.

Saving Toner

To save toner, press the **Toner Save** button on the machine control panel; see page 1.18. The button backlight turns on. Using this feature extends the life of the toner cartridge and reduces your cost per page, but it also reduces the print quality.

Expected Cartridge Life

The life of the toner cartridge depends on the amount of toner that print jobs require. When printing text at IDC 5% coverage, a new toner cartridge lasts an average of 3,000 pages. The original toner cartridge supplied with the machine lasts an average of 1,000 pages. The actual number may be different depending on the print density of the page you print. If you print a lot of graphics, you may need to change the cartridge more often.

Redistributing Toner

When the toner cartridge is near the end of its life, white streaks or light print occurs. The LCD displays the warning message, "Toner Low." You can temporarily reestablish the print quality by redistributing the remaining toner in the cartridge.

- 1 Open the front cover.
- 2 Pull the toner cartridge out and gently roll the cartridge 5 or 6 times to distribute the toner evenly inside the cartridge.

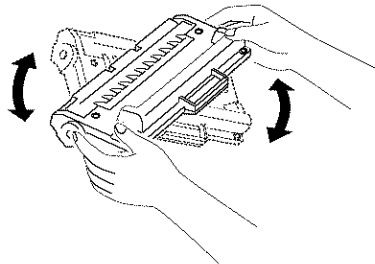

NOTE: If the toner gets on your clothing, wipe it off with a dry cloth and wash clothing in cold water. Hot water sets the toner into fabric.

- 3 Reinstall the cartridge and close the front cover.

Replacing the Toner Cartridge

When the toner eventually runs out, only blank pages print when a print job is sent or when a fax is received. At this stage, the toner cartridge needs to be replaced. The display on the control panel shows the warning message, "Toner Empty" and the machine stops printing.



NOTE: You can set the machine to ignore the "Toner Empty" message and continue printing. See page 5.8.

- 1 Open the front cover.
- 2 Lightly pushing the used cartridge down, pull it out.
- 3 Unpack the new toner cartridge and gently roll it horizontally four or five times to distribute the toner evenly inside the cartridge.
Save the box and the cover for shipping.
- 4 Slide the new toner cartridge in until it locks into place.
- 5 Close the front cover.

Setting the Notify Toner Option

If you have set the Notify Toner menu option to "On", your machine automatically sends a fax to your service company or the dealer to notify them that your machine requires a new toner cartridge when the toner cartridge needs to be replaced. The fax number is preset by your dealer when you bought your machine.

- 1 Press **Menu** on the control panel until "Maintenance" appears on the top line of the display.
The first available menu item, "Clean Drum," displays on the bottom line.
- 2 Press the scroll button (◀ or ▶) to display "Notify Toner " on the bottom line and press **Enter**.
- 3 Press the scroll button (◀ or ▶) to change the setting.
Select "On" to enable this feature. Selecting "Off" disables this feature.
- 4 Press **Enter** to save the selection.

Cleaning the Drum

If there are streaks or spots on your print, the OPC drum of the cartridge may require cleaning.

- 1 Before setting the cleaning procedure, make sure that paper is loaded in the machine.
- 2 Press **Menu** on the control panel until "Maintenance" appears on the top line of the display.
The first available menu item, "Clean Drum," displays on the bottom line.
- 3 Press **Enter**.

- 4 When the display asks you to confirm your selection, press **Enter**.
The machine prints a cleaning page. Toner particles on the drum surface are affixed to the paper.
- 5 If the problem remains, repeat steps 1 through 4.

Ignoring the Toner Empty Message

When the toner cartridge is empty, the machine shows a "Toner Empty" message and stops printing.

You can set the machine to ignore the message when it displays and to continue printing the pages.

- 1 Press **Menu** until "Machine Setup" appears on the display.
- 2 Press the scroll button (◀ or ▶) until "Ignore Toner" appears on the bottom line and press **Enter**.
- 3 Press the Scroll button (◀ or ▶) to select "On" or "Off."
Select "On" to ignore the Toner Empty message.
Select "Off" to stop printing when the message appears. This is the default setting.
- 4 Press **Enter** to save the selection.

Consumables and Replacement Parts

From time to time, you need to replace the toner cartridge, roller, and fuser unit to maintain top performance and to avoid print quality problems and paper feed problems resulting from worn parts.

The following items should be replaced after you have printed a specified number of pages:

Items	Yield (Average)
ADF rubber pad	Approx. 10,000 pages
ADF roller	Approx. 60,000 pages
Paper feeding roller	Approx. 60,000 pages
Transfer roller	Approx. 60,000 pages
Fuser unit	Approx. 60,000 pages

To purchase the consumables and replacement parts, contact your Samsung dealer or the retailer where you bought your machine. We strongly recommend that items be installed by a trained service professional, except for the toner cartridge and the ADF rubber pad.

Replacing the ADF Rubber Pad

You can purchase a ADF rubber assembly from a Samsung dealer or the retailer where you bought your machine.

- 1 Open the control panel by gripping its bottom and pulling it upward.
- 2 Disconnect the support on the left side of the machine from the control panel and lift the control panel up to the complete open position
- 3 Remove the control panel from the machine by disconnecting the hinge on the right.

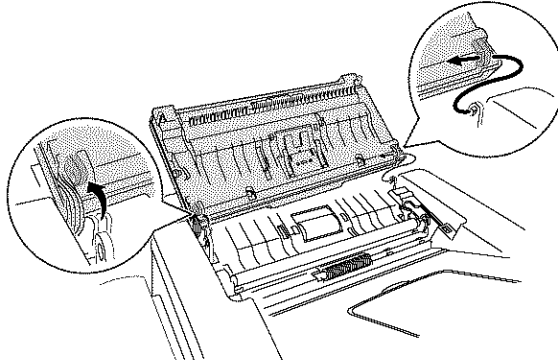

NOTE: Be careful not to disconnect the connector on the control panel from the machine as it turns the LCD off.

- 4 Using a screw driver, press the slots on the ADF rubber plate to unlatch the plate and the ADF rubber.

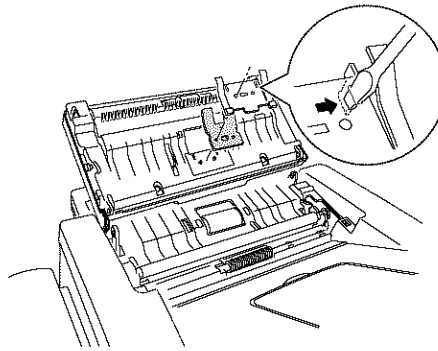

- 5 Align the holes on the new ADF rubber and the plate and inset the tabs on the plate into the slots on the machine. Press them until they are latched.
- 6 Replace the control panel by connecting the hinge on the right first then inserting the left arm while pushing the control panel to the right.
- 7 Reconnect the support and the control panel, then close the control panel firmly until it clicks into place.

MEMO



6

TROUBLESHOOTING

This chapter gives helpful information for what to do if you encounter an error.

This chapter includes:

- **Clearing Document Jams**
- **Clearing Paper Jams**
- **Clearing LCD Error Messages**
- **Solving Problems**

Clearing Document Jams

When a document jams while it passes through the ADF (Automatic Document Feeder), "Document Jam" appears on the display.

Input Misfeed

- 1 Remove the remaining documents from the ADF.
- 2 Pull the jammed document gently out of the ADF.

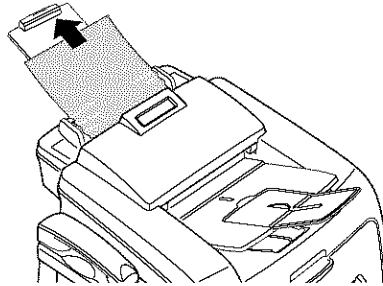

- 3 Load the documents back into the ADF.



NOTE: To prevent document jams, do not use thick, thin or mixed documents.

Exit Misfeed

- 1 Remove the remaining documents from the ADF.
- 2 Open the control panel by gripping its bottom and pulling it upward.
- 3 Pull the document gently out of the ADF.

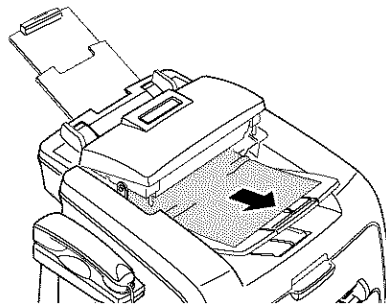

- 4 Close the control panel. Then load the documents back into the ADF.

Clearing Paper Jams

When a paper jam occurs, "Paper Jam" appears on the display. Refer to the table below to locate and clear the paper jam.

Message	Location of Jam	Go to
[Paper Jam 0] Open/Close Door	In the paper tray.	page 6.3
[Paper Jam 1] Open/Close Door	In the fuser area or around the toner cartridge.	page 6.4
	In the manual feeder	page 6.5
[Paper Jam 2] Check Inside	In the paper exit area	page 6.4

To avoid tearing the paper, pull the jammed paper out gently and slowly. Follow the steps on the next pages to clear the jam.

In the Paper Tray

- 1 Open and close the front cover. The jammed paper automatically exits the machine.
If the paper does not exit, continue to step 2.
- 2 Pull the paper tray open.
- 3 Remove the jammed paper by gently pulling it straight out.

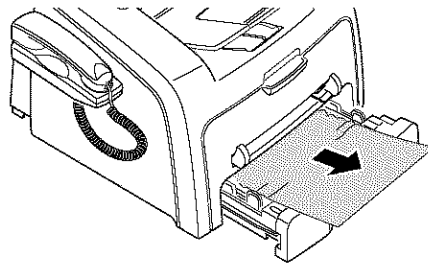

If there is any resistance and the paper does not move when you pull or if you cannot see the paper in this area, skip to the fuser area around the toner cartridge. See page 6.4.

- 4 Insert the paper tray into the machine until it snaps into place.
- 5 Open and close the front cover to resume printing.

In the Paper Exit Area

- 1 Open and close the front cover. The jammed paper automatically exits the machine.
If the paper does not exit, continue to step 2.
- 2 Gently pull the paper out of the front output tray. Skip to step 6.

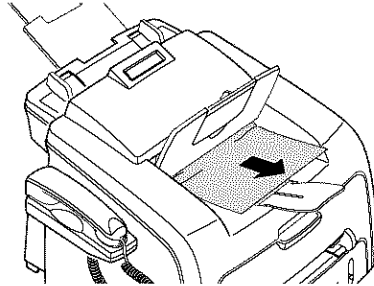

If there is any resistance and the paper does not move when you pull or if you cannot see the paper in the front output tray, continue to step 3.

- 3 Open the rear cover.
- 4 Remove the jammed paper by gently pulling it straight out.

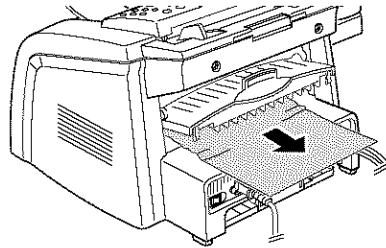

- 5 Close the rear cover.
- 6 Open and close the front cover to resume printing.

In the Fuser Area or Around the Toner Cartridge



NOTE: The fuser area is hot. Take care when removing paper from the machine.

- 1 Open the front cover and pull the toner cartridge out, lightly pushing it down.
- 2 Remove the jammed paper by gently pulling it straight out.

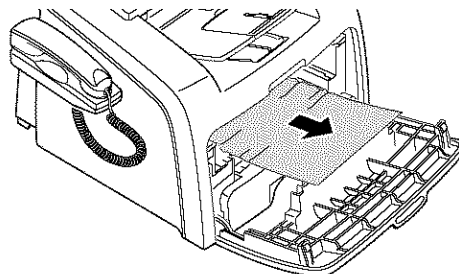

- 3 Replace the toner cartridge and close the front cover. Printing automatically resumes.

In the Manual Feeder

[Paper Jam 1]
" Open/Close Door " appears on the display when you try to print using the manual feeder and the machine does not detect paper, due to no paper or improper paper loading.

The error message may also occur when the paper is not properly fed into the machine through the manual feeder. In that case, pull the paper out of the machine.

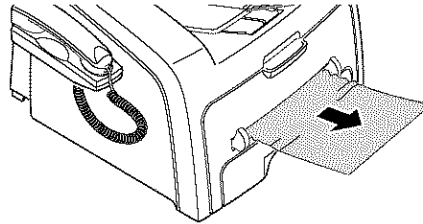

Tips for Avoiding Paper Jams

By selecting the correct paper types, most paper jams can be avoided. When a paper jam occurs, follow the steps outlined in page 6.3.

- Follow the procedures on page 1.9 when you load paper. Ensure that the adjustable guides are positioned correctly.
- Do not overload the paper tray. Ensure that the paper is below the paper capacity mark on the inside wall of the paper tray.
- Do not remove the paper from the tray while your machine is printing.
- Flex, fan and straighten the paper before loading.
- Do not use creased, damp or highly curled paper.
- Do not mix paper types in the paper tray.
- Use only recommended print materials. See "Paper Specifications" on page A.5.
- Ensure that the print side of print materials is facing down in the paper tray and facing up in the manual feeder.

Clearing LCD Error Messages

Messages appears on the display to indicate the control panel to indicate the machine's status or errors. Refer to the following table to understand the message's meaning and correct the problem, if necessary. Messages and their meanings are listed in alphabetical order.

Display	Meaning	Suggested solutions
Cancel ? 1:Yes 2:No	Your machine's memory is full during the machine stores the document into the memory.	To cancel the fax job, press the 1 button to accept "Yes" If you want to send the pages were stored, press the 2 button to accept "No." You should send the remaining pages later when the memory is available.
[Comm. Error]	The machine has a communication problem.	Ask the sender to try again.
CRU Fuse Error	The machine has a problem with recognizing the new toner cartridge.	Please contact a service representative.
Document Jam	The loaded document has jammed in the ADF (Automatic Document Feeder).	Clear the document jam. See page 6.2.
[Door Open]	The front or rear cover is not securely latched.	Close the cover until it locks into place.
Group Not Available	You have tried to select a group location number where only a single location number can be used, such as when adding locations for a broadcasting operation.	Just use a one-touch or speed dial number or dial a number manually using the number keypad.
[Incompatible]	The remote machine does not have the requested feature, such as a delayed transmission. It also occurs if the remote machine does not have enough memory space to complete the operation you are attempting.	Reconfirm the remote machine's features.
[Jam 1] or [No Cartridge]	The toner cartridge is not installed.	Install the toner cartridge. See page 1.8.
Line Busy	The remote person did not answer or the line is already engaged.	Try again after a few minutes.
[Line Error]	Your machine cannot connect with the remote machine or has lost contact because of a problem with the phone line.	Try again. If the problem persists, wait an hour or so for the line to clear and try again. Or, turn the ECM on. See page 4.5.

Display	Meaning	Suggested solutions
Load Document	You have attempted to set up a copy or fax operation with no document loaded.	Load a document and try again.
[Low Heat Error]	There is a problem in the fuser unit.	Unplug the power cord and plug it back in. If the problem persists, please contact a service representative.
Open Heat Error		
[Over Heat]		
[LSU Error]	A problem has occurred in the LSU (Laser Scanning Unit).	Unplug the power cord and plug it back in. If the problem persists, please call for service.
Memory Full	The memory is full.	Delete unnecessary documents, retransmit after more memory becomes available or split the transmission into more than one operation.
[No Answer]	The remote fax machine has not answered after several redial attempts.	Try again. Make sure that the remote machine is operational.
NO. Not Assigned	The One-touch or speed dial location you tried to use has no number assigned to it.	Dial the number manually using the number keypad or assign the number. For storing a number, see page 2.16.
[No Paper] Add Paper	The paper tray has run out of paper.	Load paper in the paper tray. See page 1.9.
Operation Not Assigned	You are doing in the Add/Cancel operation, but there is no jobs waiting.	Check the display to see if there is any scheduled job. The display should indicate them in Standby mode, for example, Delay Fax.
[Paper Jam 0] Open/Close Door	Paper has jammed in the feeding area of the paper tray.	Clear the jam. See page 6.3.
[Paper Jam 1] Open/Close Door	<ul style="list-style-type: none"> Paper has jammed in the paper exit area. A paper jam has occurred in the manual feeder or the machine detects non-feeding from the manual feeder. 	<ul style="list-style-type: none"> Clear the jam. See page 6.4. Clear the jam. See page 6.5.
[Paper Jam 2] Check Inside	Paper has jammed in the fuser area.	Clear the jam. See page 6.4.
Power Failure	Power has turned off then on and the machine's memory has not been saved.	You need to start again the job which you were trying to do before the power failure.
Retry Redial?	The machine is waiting for a specified time interval to redial a previously busy station.	You can press Enter to immediately redial, or Stop/Clear to cancel the redial operation.

Display	Meaning	Suggested solutions
[Stop Pressed]	The Stop/Clear button is pressed during a copy or fax operation.	Try again.
[Toner Empty]	The toner cartridge has run out. The machine stops printing.	Replace with a new toner cartridge. See page 5.7.
[Toner Low]	The toner cartridge is almost empty.	Take out the toner cartridge and gently shake it. By doing this, you can temporarily reestablish printing operations.

Solving Problems

The following chart lists some conditions that may occur and the recommended solutions. Follow the suggested solutions until the problem is corrected. If the problem persists, please call for service.

Paper Feeding Problems

Condition	Suggested solutions
Paper is jammed during printing.	Clear the paper jam. See page 6.3.
Paper sticks together.	Ensure that there is not too much paper in the paper tray. The paper tray can hold up to 250 sheets of paper, depending on the thickness of your paper. Make sure that you are using the correct type of paper. See "Paper Specifications" on page A.5. Remove paper from the paper tray and flex or fan the paper. Humid conditions may cause some paper to stick together.
Multiple sheets of paper do not feed.	Different types of paper may be stacked in the paper tray. Load the paper of only one type, size and weight. If multiple sheets have caused a paper jam, clear the paper jam. See page 6.3.
Paper does not feed into the machine.	Remove any obstructions inside the machine. Paper has not been loaded correctly. Remove paper from the tray and reload it correctly. There is too much paper in the paper tray. Remove excess paper from the tray. The paper is too thick. Use only paper that meets the specifications required by the machine. See "Paper Specifications" on page A.5.

Condition	Suggested solutions
The paper keeps jamming.	<ul style="list-style-type: none"> • There is too much paper in the paper tray. Remove excess paper from the tray. • An incorrect type of paper is being used. Use only paper that meets the specifications required by the machine. See "Paper Specifications" on page A.5. If you are printing on special materials, use the manual feeder. • There may be debris inside the machine. Open the front cover and remove the debris.
Transparencies stick together in the paper exit.	Use only the transparencies specifically designed for a laser printer. Remove each transparency as it exits from the machine.
Envelopes skew or fail to feed correctly.	Ensure that the paper guides are against both sides of the envelopes.

Copying Problems

Condition	Suggested solutions
Copies are too light or too dark.	Use the Darkness button to darken or lighten the background of the copies.
Smears, lines, marks or spots appears on copies.	<ul style="list-style-type: none"> • If defects are on the original document, press the Darkness button to lighten the background of your copies. • If no defects are on the original document, clean the scan unit. See page 5.4.
Copy image is skewed.	<ul style="list-style-type: none"> • Ensure that the original document is positioned correctly in the ADF (Automatic Document Feeder). • Check that the copy paper is loaded correctly.
Blank copies print out.	Ensure that the original document is face down in the ADF.
Image rubs off the copy easily.	<ul style="list-style-type: none"> • Replace the paper in the paper tray with paper from a new package. • In high humidity areas, do not leave paper in the machine for the extended periods of time.
Frequent copy paper jams occurs.	<ul style="list-style-type: none"> • Fan the stack of paper, then turn it over in the paper tray. Replace the paper in the tray with a fresh supply. Check/adjust the paper guides, if necessary. • Ensure that the paper is the proper paper weight. 75g/m² (20 lb) bond paper is recommended. • Check for copy paper or pieces of copy paper remaining in the machine after a paper jam has been cleared.
Fewer copies from the toner cartridge than expected prints out.	<ul style="list-style-type: none"> • Your original documents may contain pictures, solids or heavy lines. For example, they may be forms, newsletters, books or other documents that use more toner. • The machine may be turned frequently on and off.

Faxing Problems

Condition	Suggested solutions
The machine is not working, there is no display and the buttons are not working.	<ul style="list-style-type: none"> • Unplug the power cord and plug it in again. • Ensure that there is power to the electrical receptacle.
No dial tone sounds.	<ul style="list-style-type: none"> • Check that the phone line is connected properly. • Check that the phone socket in the wall is working by plugging in another phone.
The numbers stored in the memory do not dial correctly.	Make sure that the numbers are stored in the memory correctly. Print a Phonebook list, referring to page 2.16.
The document does not feed into the machine.	<ul style="list-style-type: none"> • Make sure that the document is not wrinkled and you are putting it in correctly. Check that the document is the right size, not too thick or thin. • Make sure that the control panel is firmly closed.
Faxes are not received automatically.	<ul style="list-style-type: none"> • Fax mode should be selected. • Make sure that there is paper in the tray. • Check to see if the display shows "Memory Full."
The machine does not send.	<ul style="list-style-type: none"> • Make sure that the document is loaded in the ADF. • "TX" should show up on the display. • Check the other fax machine you are sending to, to see if it can receive your fax.
The incoming fax has blank spaces or is received with a poor-quality.	<ul style="list-style-type: none"> • The fax machine sending you the fax may be faulty. • A noisy phone line can cause line errors. • Check your machine by making a copy. • The toner cartridge may be empty. Replace the toner cartridge, referring to page 5.7.
Some of the words on a incoming fax are stretched.	The fax machine sending you the fax had a temporary document jam.
There are lines on the documents you send.	Check your scan unit for marks and clean it. See page 5.4.
The machine dials a number, but a connection with another fax machine fails.	The other fax machine may be turned off, out of paper, or cannot answer incoming calls. Speak with the other machine operator and ask her/him to clear out the problem.
Documents are not stored in the memory.	There may not be enough memory to store the document. If the display shows a "Memory Full" message, delete any documents you no longer need from the memory and then restore the document.
Blank areas appear at the bottom of each page or on other pages, with a small strip of text at the top.	You may have chosen the wrong paper settings in the user option setting. See page 1.16.



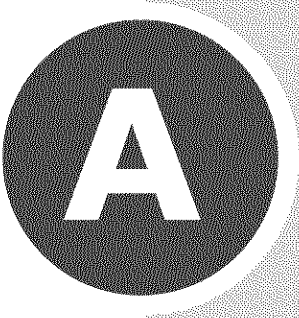

SPECIFICATIONS

This chapter includes:

- **General Specifications**
- **Copier Specifications**
- **Facsimile Specifications**
- **Paper Specifications**

General Specifications

Item	Description
ADF Capacity	20 sheets (Document size: Letter, A4 Document weight: 75g/m ² , 20lb)
ADF Document size	Width: 142 to 216 mm (5.6 to 8.5 inches) Length: 148 to 356 mm (5.8 to 14 inches)
Paper input capacity	250 sheets (weight: 75 g/m ² , 20 lb)
Paper output capacity	Front output tray: 150 sheets (face down) Rear output slot: 1 sheet (face up)
Consumables	Type: Single Cartridge Yield: 3,000 pages (for starter, 1,000 pages) @ IDC 5 % coverage*
Duty Cycle , monthly	Up to 10,000 pages
Power requirements	100 ~ 127 VAC, 50/60 Hz, 4.0A 220 ~ 240 VAC, 50/60 Hz, 2.5A
Power consumption	Sleep mode: 10 W(100 ~ 127 VAC) / 12 W(220~240 VAC) Standby mode: 85 W(100 ~ 127 VAC) / 95 W(220 ~ 240 VAC) Average: 300 W
Noise Level **	Warm-up: Less than 52 dBA Standby mode: Less than 39 dBA Scanning: Less than 52 dBA Printing: Less than 52 dBA
Warm-up Time	35 seconds
Operating conditions	Temperature: 50 °F to 89 °F (10 °C to 32 °C) Humidity: 20 % to 80 % RH
LCD	16 characters x 2 lines
SET dimension (W x D x H)	363.0 x 398.5 x 308.3 mm(14.3 x 15.7 x 12.1 inches) (without the handset)
Weight	Net: 9.7Kg(21.4 lbs) (including consumables) Gross: 11.7Kg(25.8 lbs) (including consumables, accessories and package)
Package weight	Paper: 2.7 Kg(6 lbs) Plastic: 0.7 Kg(1.5 lbs)

* May be affected by operating environment, printing interval, media type and media size.

** Sound Pressure Level, ISO 7779

Copier Specifications

Item	Description
Compatibility	TWAIN standard
Scan method	CIS, Mono
Scan resolution	Up to 200 X 200 dpi (Optical)
Scan length	Maximum: 15.7 inches (400 mm)
Scan width	Maximum: 8.5 inches (216 mm) Effective: 8.2 inches (208 mm)
Mono bit depth	1 bit for Text mode 8 bit for Gray mode
Copy speed (SDMC)*	Up to 16 ppm in A4 (17 ppm in Letter)
Copy speed (MDSC)**	Up to 7 ppm in A4 (8 ppm in Letter)
Paper type	Paper tray: Plain paper (60 ~ 90 g/m ² , 16 ~ 24 lb) Manual feeder: Plain paper, Transparencies, Labels
Copy resolution	Up to 300 x 300 dpi
Zoom rate	50 ~ 150%
Multiple copies	1~99 pages
Halftone	256 levels

* Copy Speed is based on Single Document Multiple Copy

** Copy Speed is based on Multiple Document Single Copy

Facsimile Specifications

Item	Description
Compatibility	ITU-T Group 3
Applicable line	Public Switched Telephone Network (PSTN) or behind PABX
Data coding	MH/MR/MMR (ECM Mode)
Modem speed	33600/31200/28800/26400/24000/21600/19200/16800/ 14400/12000/9600/7200/4800/2400 bps with fall back
Transmission speed	Approx. 3 seconds per page*
Scan speed	Approx. 6 seconds per page**
Paper type	Plain paper (60 ~ 90 g/m ² , 16 ~ 24 lb)
Paper size	Letter, A4, Legal, Executive, Folio , B5
Resolution	Standard: Up to 203 x 98 dpi Fine: Up to 203 x 196 dpi Super Fine: Up to 203 x 392 dpi Photo: Up to 203 x 196 dpi
Memory	2 MB(Approx. 400 pages at ITU-T #1 Chart)
Halftone	256 levels
Auto dialer	One-touch dialing (20 Locations) Speed dialing (80 Locations)

* Condition: Standard resolution, MMR(JBIG), 33,6 Kbps, Phase "C" by ITU-T No.1 Chart, Memory Tx, ECM

** Condition: ITU-T No.1 Chart, Standard Resolution

Paper Specifications

Overview

Your machine accepts a variety of print materials, such as cut-sheet paper, including up to 100% recycled fiber content paper, envelopes, labels, transparencies and custom-size paper. Properties, such as weight, composition, grain and moisture content, are important factors affecting the machine's performance and the output quality. Paper that does not meet the guidelines outlined in this user's guide can cause the following problems:

- Poor print quality
- Increased paper jams
- Premature wear on the machine.

NOTES:

- Some paper may meet all of the guidelines in this guide and still not produce satisfactory results. This may be the result of improper handling, unacceptable temperature and humidity levels, or other variables over which Samsung has no control.
- Before purchasing large quantities of paper, insure the paper meets the requirements specified in this user's guide.

CAUTION: Using paper that does not meet these specifications may cause problems, requiring repairs. These repairs are not covered by the Samsung warranty or service agreements.

Supported Sizes of Paper

Size (mm/in.)	Weight	Capacity*
Plain paper Letter (215.9 x 279/8.5 x 11) A4 (210 x 297/8.27 x 11.69) Folio (215.9 x 330.2/8.5 x 13) Legal (215.9 x 355.6/8.5 x 14) Executive (184.2 x 266.7/7.25 x 10.5) B5(182 x 257/7.2 x 10)	<ul style="list-style-type: none">• 60 to 90 g/m² bond (16 to 24 lb) for the paper tray• 60 to 163 g/m² bond (16 to 43 lb) for the manual feeder	<ul style="list-style-type: none">• 250 sheets of 75 g/m² bond (20 lb) paper for the paper tray• 1 sheet of paper for the manual feeder
Labels Letter (215.9 x 279/8.5 x 11) A4 (210 x 297/8.27 x 11.69)	120 to 150 g/m ²	1 sheet of paper for the manual feeder
Transparencies Letter (215.9 x 279/8.5 x 11) A4 (210 x 297/8.27 x 11.69)	138 to 146 g/m ²	

* Capacity may vary depending on print materials' weight and thickness, and environmental conditions.

NOTE: You may experience jams when using print materials with a length of less than 127 mm (5 in.). For optimum performance, ensure that you are storing and handling the paper correctly. Please refer to "Paper Storage Environment" on page A.7.

Guidelines for Using Paper

For the best result, use conventional 75 g/m² (20 lb) paper. Ensure that the paper is of good quality, and free of cuts, nicks, tears, spots, loose particles, dust, wrinkles, voids, and curled or bent edges.

If you are unsure of what type of paper you are loading, such as bond or recycled paper, check the label on the package.

The following problems may cause print quality deviations, jamming or even damage to the machine:

Symptom	Problem with Paper	Solution
Poor print quality or toner adhesion, problems with feeding	Too moist, too rough, too smooth or embossed; faulty paper lot	Try another kind of paper, between 100 ~ 400 Sheffield, 4 ~ 5 % moisture content.
Dropout, jamming, curl	Stored improperly	Store paper flat in its moisture-proof wrapping.
Increased gray background shading/machine wear	Too heavy	Use lighter paper, use the rear output slot.
Excessive curl problems with feeding	Too moist, wrong grain direction or short-grain construction	Use the rear output slot. Use long-grain paper.
Jamming, damage to machine	Cutouts or perforations	Do not use paper with cutouts or perforations.
Problems with feeding	Ragged edges	Use good quality paper.

NOTES:

- Do not use letterhead paper printed with low-temperature inks, such as those used in some types of thermography.
- Do not use raised or embossed letterhead.
- The machine uses heat and pressure to fuse toner to the paper. Insure that any colored paper or preprinted forms use inks that are compatible with this fusing temperature (200 °C or 392 °F for 0.1 second).

Paper Specifications

Category	Specifications
Acid Content	5.5 pH or lower
Caliper	0.094 ~ 0.18 mm (3.0 ~ 7.0 mils)
Curl in Ream	Flat within 5 mm (0.02 in.)
Cut Edge Conditions	Cut with sharp blades with no visible fray.
Fusing Compatibility	Must not scorch, melt, offset or release hazardous emissions when heated to 200 °C (392 °F) for 0.1 second.
Grain	Long Grain
Moisture Content	4 % ~ 6 % by weight
Smoothness	100 ~ 400 Sheffield

Paper Storage Environment

Paper storage environmental conditions directly affect the feed operation.

Ideally, the machine and paper storage environment should be at or near room temperature, and not too dry or humid. Remember that paper is hygroscopic; it absorbs and loses moisture rapidly.

Heat works with humidity to damage paper. Heat causes the moisture in paper to evaporate, while cold causes it to condense on the sheets. Heating systems and air conditioners remove most of the humidity from a room. As paper is opened and used, it loses moisture, causing streaks and smudging. Humid weather or water coolers can cause the humidity to increase in a room. As paper is opened and used it absorbs any excess moisture, causing light print and dropouts. Also, as paper loses and gains moisture it can become distorted. This can cause paper jams.

Care should be taken not to purchase more paper than can be used in a short time (about 3 months). Paper stored for long periods may experience heat and moisture extremes, which can cause damage. Planning is important to prevent damage to large supplies of paper.

Unopened paper in sealed reams can remain stable for several months before use. Opened packages of paper have more potential for environment damage, especially if they are not wrapped with a moisture-proof barrier.

The paper storage environment should be properly maintained to ensure optimum performance. The required condition is 20 to 24 °C (68 to 75 °F), with a relative humidity of 45 % to 55 %. The following guidelines should be considered when evaluating the paper's storage environment:

- Paper should be stored at or near room temperature.
- The air should not be too dry or too humid.
- The best way to store an opened ream of paper is to rewrap it tightly in its moisture-proof wrapping. If the machine environment is subject to extremes, unwrap only the amount of paper to be used during the day's operation to prevent unwanted moisture changes.

MEMO



A.8

SPECIFICATIONS

INDEX

A

- adding documents 3.6
- ADF (Automatic Document Feeder), load 2.2
- automatic dialing
 - group 2.18
 - one-touch 2.16
 - speed 2.17
- automatic redialing 2.5

B

- broadcasting faxes 3.2

C

- canceling
 - fax 2.4
 - scheduled faxes 3.6
- characters, enter 1.14
- cleaning
 - drum 5.7
 - inside 5.3
 - outside 5.3
 - scan unit 5.4
- connection
 - AC power 1.12
 - telephone line cord 1.11
- consumables 5.8
- control panel 1.5
- copy
 - default setting, change 2.14
 - image 2.12
 - number of pages 2.13
 - time out, set 2.14

D

- date and time, set 1.15
- delay receive polling 3.4
- delayed fax 3.2
- display language, change
 - control panel 1.13
- document
 - loading 2.2
 - preparing 2.2
- document jam, clear 6.2
- drum, clean 5.7

E

- error messages 6.6
- extension phone, connect 1.11

F

- fax system, set
 - advanced settings 4.4
 - basic settings 1.19

G

- group dial
 - dialing 2.19
 - editing 2.19
 - setting 2.18

H

- handset, attach 1.7

J

- jam, clear
 - document 6.2
 - paper 6.3

M

- machine ID, set 1.13
- manual feeder, paper load 2.10
- memory, clear 5.2

O

- one-touch dial
 - dialing 2.16
 - storing 2.16

P

- paper jam, clear 6.3
- paper level indicator 2.6
- paper size, set 1.16
- paper tray, paper load 1.9
- paper type, set 1.16
 - manual feeder 2.11
- paper, load 1.9
- polling 3.4
- power save mode, use 1.19

- print
 - Phonebook list 2.20
 - reports 4.3
- priority fax 3.4
- problem, solve
 - copying 6.9
 - error messages 6.6
 - faxing 6.10
 - paper feeding 6.8

R

- rear output slot 2.11
- receiving a fax
 - in Ans/Fax mode 2.7
 - in Fax mode 2.7
 - in Secure Receiving mode 4.2
 - in Tel mode 2.7
 - in the memory 2.9
- redial, last number 3.2
- reduced/enlarged
 - copy 2.13
- reports, print 4.3
- resolution, set 2.3

S

- searching Phonebook 2.20
- sending a fax
 - automatically 2.4
 - manually 2.4
- shading, adjust 5.3
- sounds, set 1.17
- specifications
 - facsimile A.4
 - general A.2
 - paper A.5
 - scanner and copier A.3
- speed dial
 - dialing 2.17
 - storing 2.17

T

- tel line, connect 1.11
- toil save mode, use 1.18
- toner cartridge
 - install 1.8
 - life 5.6
 - redistribute 5.6
 - replace 5.7
- toner save mode, use 1.18

V

- volume, adjust
 - ringer 1.17
 - speaker 1.17



Home

Visit us at:

www.samsungprinter.com

P/N:JC68-01253A Rev.2.00