

# Contents

## Chapter 1. Overview

1.1 Function .....	4
1.2 Feature .....	4
1.3 Composition .....	4
1.4 Construction .....	5
1.5 Specifications .....	7
1.5.1 General .....	7
1.5.2 Scanner (RSU-3700) .....	7
1.5.3 Display Unit (SMR-3700) .....	8
1.5.4 Connection Cable .....	9

## Chapter 2. How to operate panel and menu

2.1 Front Panel Buttons and Knob .....	10
2.1.1 Front Function .....	10
2.1.2 Directional Key .....	11
2.1.3 Display Characters .....	11
2.2. Display Description .....	12
2.3. Menu Functions .....	13
2.3.1 Menu Composition .....	13
2.3.2 MENU Functions .....	16

## Chapter 3. How to operate the unit

3.1 General Idea .....	21
3.1.1 Power Input and Operation .....	21
3.1.2 Tuning Control .....	21
3.1.3 Image Control .....	21
3.1.4 Power Off .....	22
3.2 Stand-by for Processing .....	22
3.2.1 Brightness Change .....	22
3.2.2 Language Selection .....	22
3.3 Basic Operation .....	22
3.3.1 TX .....	22
3.3.2 TX Stop .....	22
3.3.3 Tuning Control .....	22

3.3.4 Gain Control .....	23
3.3.5 Rain/Snow Removal .....	24
3.3.6 To remove the interference of Sea Level Wave caused by the Sea Wave .....	25
3.3.7 To operate the alert function .....	26
3.3.8 To eliminate/display the scale of Range Ring .....	26
3.3.9 To remove the Radar Interference .....	27
3.3.10 To eliminate the Ship's Heading Line .....	27
3.3.11 To use the parallel line .....	28
3.3.12 To move the center of own ship .....	28
3.3.13 To measure the distance and bearing to the Target .....	28
3.3.14 To change distance unit .....	29
3.3.15 To change the way of direction symbol .....	30
3.3.16 To change the way of bearing display .....	33
3.3.17 To change the way of displaying bearing line/cursor .....	33
3.3.18 To compensate the magnetic .....	33
3.3.19 To measure the time to the target .....	34
3.3.20 To display the Waypoint .....	34
3.3.21 To display the other ship's track line .....	34
3.5 Connection to the external navigation equipment .....	35

## Chapter 4. Screen view

4.1 The distance from the target to the height of target .....	36
4.2 Reflection from the target .....	37
4.3 Wave Path .....	37
4.3.1 Reflection of sea level.....	37
4.3.2 False Image.....	38

## Chapter 5. Installation

5.1 Overview .....	39
5.2 Installation of Scanner.....	39
5.2.1 Selection of the installation place .....	39
5.2.2 How to install Antenna .....	40
5.2.3 Connection to Equipment cable .....	41
5.3 DISPLAY SET-UP .....	43
5.3.1 Location for installation .....	43
5.3.2 How to Install .....	43
5.3.3 Power Cable connection .....	43
5.4 Installation check .....	43

5.5 Operation check .....	43
5.6 Initial Installation .....	44
5.6.1 Initial Installation .....	44
5.6.2 TUNE-R SET (Tuning Set).....	45
5.6.3 TUNE SET (Tune Level Set).....	45
5.6.4 Video ADJ .....	45
5.6.5 MBS ADJ .....	45
5.6.6 Tune ADJ .....	45
5.6.7 MT-RPM ADJ .....	46
5.6.8 Upgrading software .....	46
5.6.9 Setting .....	46
5.6.10 Factory default set .....	46

## Chapter 6. Maintenance

6.1 General Maintenance .....	47
6.1.1 Cleaning .....	47
6.1.2 Check out the tightness of screw, bolt .....	47
6.1.3 Check the cabling .....	47
6.2 Scanner .....	47
6.2.1 Radom .....	47
6.2.2 Bracket .....	48
6.3 Display .....	48
6.3.1 Cleaning of a Display Screen.....	48

## Chapter 7. Installation drawing and circuit diagram

# Chapter 1. Overview

## 1.1 Function

This equipment is a small-sized raster scanning Radar, which composes Radom type transceiver with 4 KW Transmitting power and 10.4 inch color TFT LCD monitor.

This equipment is radar which complies with the regulation of frequency law.

## 1.2 Feature

### Scanner Unit

It emits the microwave toward targets by 4(four)-step pulse widths according to the radar scale and transfers the image signals to the monitor that are made by converting the reflected signals to 2(two)-step receiver band.

- Transmission Output: 4KW
- Max. Range : 36NM

### Display Unit

SMR-3600 monitor is designed to receive the input signal from Scanner and displays the optimum conditions on the TFT LCD screen, based on the SAMYUNG's best digital signaling technology.

- 10.4 " color TFT LCD, High Resolution of 640 X 480
- One-touch keys dedicated to every function
- 10 (ten)-step LCD brightness adjustments
- The input of the external navigational devices such as Gyro or NMEA 0183 enables it to display the own ship position and the destination

## 1.3 Composition

### Composition and Power Supply

Model	Scanner unit	Display unit	Power supply
SMR-3700	RSU-3700	SMR-3700	DC 12V / 24V

The models are named in English as follows

Scanner : SCANNER UNIT

Display : DISPLAY UNIT

### Components

Description	Q'y	Samyung CODE	Remark
Manual	1	SMR-3700-MK	
SCANNER-DISPLAY CABLE	1	RSU-3700-15M	15m
POWER CABLE	1	ACC-CAB-010	3m
SURGE CABLE	1	STR-595	3m

### 1.4 Construction

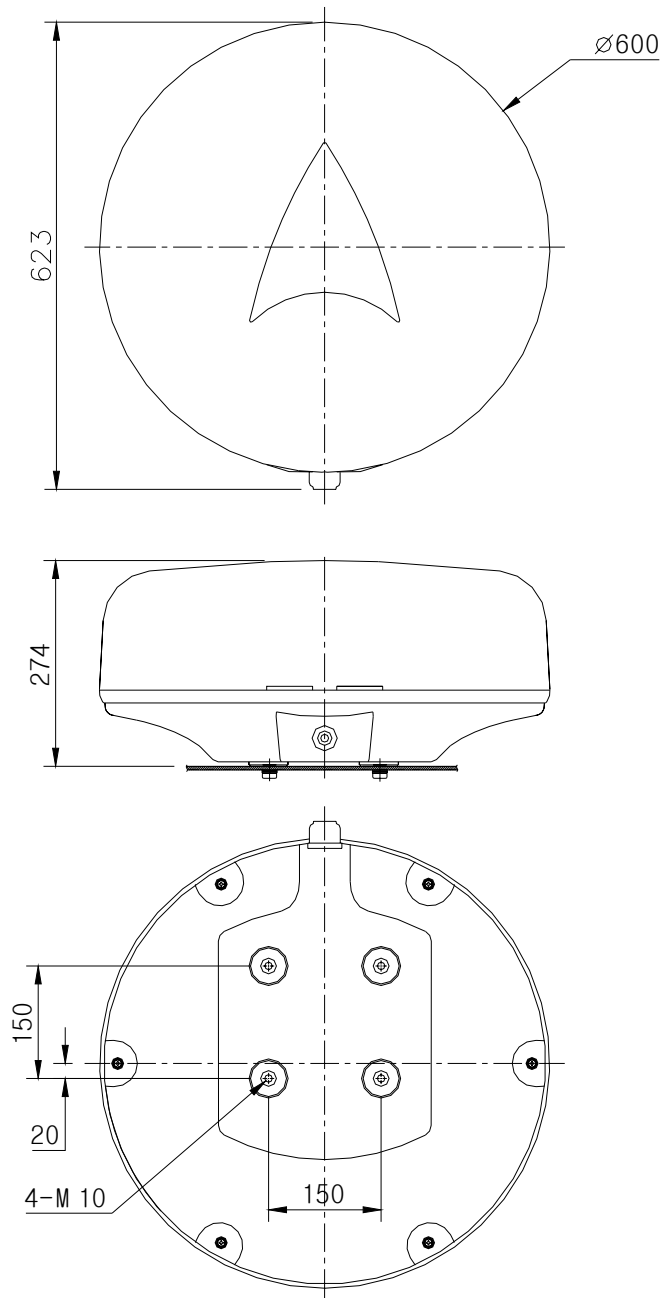

[Pic. 1.1] RSU-3700 External Diagram

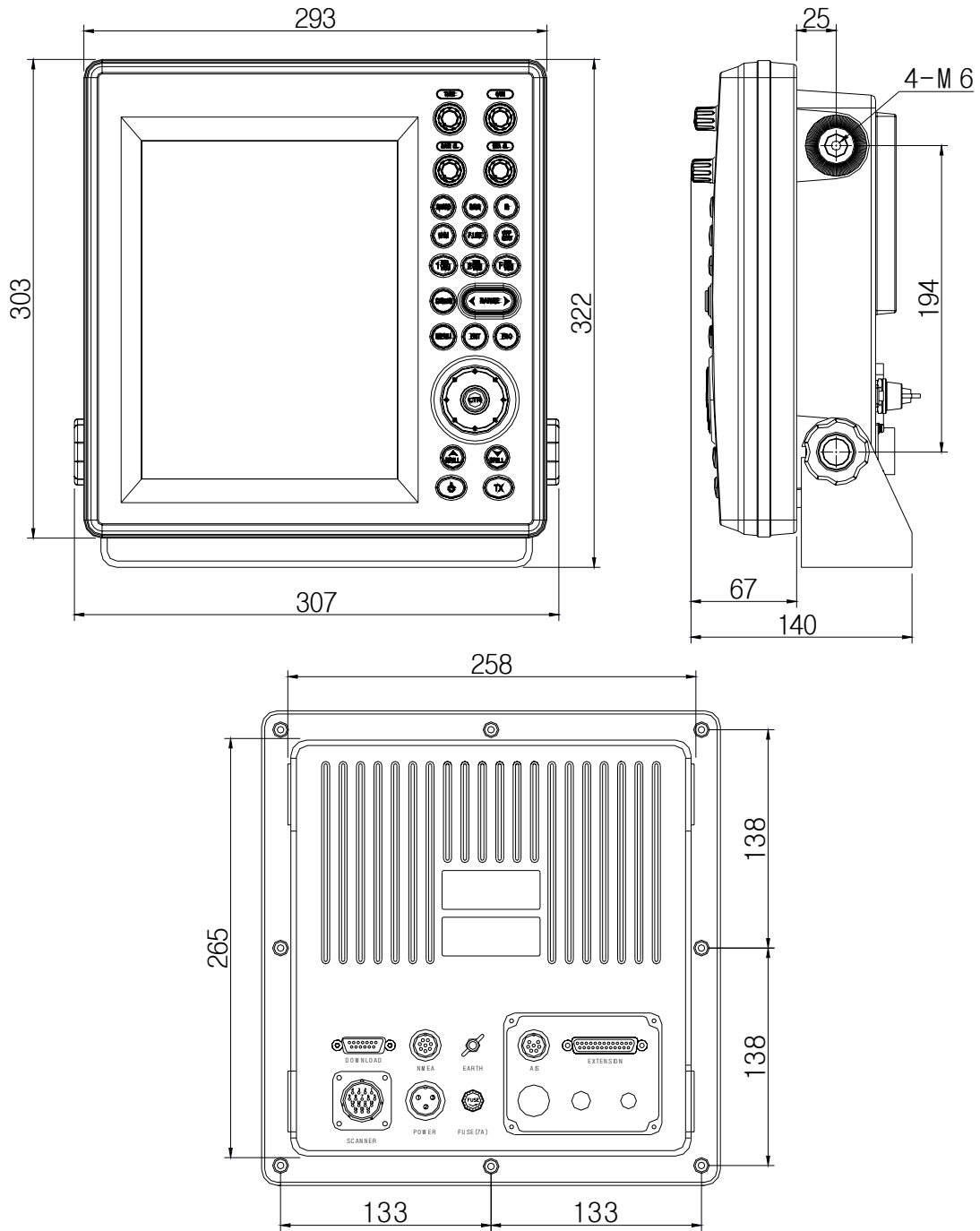

[Pic.1.2] SMR-3700 External diagram of Display

## 1.5 Specification

### 1.5.1. General

- Display Type : RASTER SCAN type
- Display Screen : 10.4" Color TFT LCD, Vertical Display
- Display Color : GREEN, YELLOW, RED, WHITE, COLOUR
- Display Range : 0.0625, 0.125, 0.25, 0.5, 0.75, 1, 1.5, 2, 3, 6, 12, 24, 36NM
- Distance Resolution : within 30m
- Min. Detection Range : within 25m
- Bearing Accuracy :  $\pm 1^\circ$
- Bearing Resolution : 4.2°
- Bearing Input : True Bearing / Magnetic Bearing
- Environmental Condition
  - 1) Temperature : Scanner -25°C ~ +55°C  
: Display -15°C ~ +55°C
  - 2) Relative Humidity : Scanner - below 95% on 35°C  
: Display - below 95% on 35°C
  - 3) Relative Wind Speed : 51.5m/sec (100knots)
- Power Consumption : 78W
- DC Power : DC12V / DC 24V
- Preheating Time : 90 Sec.
- Preaction : within 3 Sec.

### 1.5.2. Scanner(RSU-3700)

- Dimensions
  - 1) Diameter : 600mm
  - 2) Height : 274mm
- Weight : 9.0Kg (without cable)
- Plane of Polarization : Horizontal Target Wave
- Polar Pattern
  - 1) Horizontal Beam Width : 4.0°
  - 2) Vertical Beam Width : 25°
  - 3) Side Lobe Level : Below -21dB
- Revolution : Approx. 24 R/Min
- TX Frequency : 9410±30MHZ
- Emission Type : P0N

- Peel Power : 4KW
- Transmission Bulb : Magnetron JRC MAF1421BY
- Pulse Width Setup
  - 1) 0.1  $\mu$ sec / 2100Hz – 0.0625, 0.125, 0.25, 0.5, 0.75, 1NM
  - 2) 0.3  $\mu$ sec / 1650Hz – 1.5, 2, 3NM
  - 3) 0.5  $\mu$ sec / 1200Hz – 6NM
  - 4) 0.9  $\mu$ sec / 600Hz – 12, 24, 36NM

### 1.5.3. Display Unit (SMR-3700)

- Dimensions
  - 1) Width : 307mm
  - 2) Height : 332mm
  - 3) Depth : 140mm
- Construction : Desk Type
- Weight : 4.7kg
- Display Screen : 10.4" Color TFT LCD
- Scale Zoom-In : Less than the bigger one – 1% of used range or 70m
- VRM : .000 ~ 36.0 NM Digital Display
- EBL : .000° ~ 359° Digital Display
- Sync. Type : Manual/Automatic Switchable
- Bearing Scale : 1° scale, 360°
- Bearing Display : Electronic Type
- Front Panel
  - 1) Tune : Knob
  - 2) Gain : Knob / Switch
  - 3) Rain/Snow Removal : Knob / Switch
  - 4) Sea Cluter Removal : Knob / Switch
  - 5) Guard : Switch
  - 6) Distance Circle : Switch
  - 7) Interference Rejection : Switch
  - 8) Heading Line : Switch
  - 9) Parallel Line : Switch
  - 10) Center Movement : Switch
  - 11) 1 EBL/VRM : Switch



- 12) 2 EBL/VRM : Switch
- 13) F EBL/VRM : Switch
- 14) TEAIL : Switch
- 15) Distance Circle : Switch
- 16) Menu : Switch
- 17) Cursor : Switch
- 18) ESC : Switch
- 19) Enter : Switch
- 20) Direction Button : Switch
- 21) Brightness : Switch
- 23) Power : Switch
- 24) Transmission : Switch
- Menu Type : POP-UP Type

#### 1.5.4. Connection Cable

- SCANNER Cable Length : Standard 15m / Max 30m
- Power Cable Length : 3m

## Chapter 2. How to operate panel and menu

### 2.1 Front Panel Buttons and Knob

It is available to display and adjust the various data on the screen by using the the control keys as follows.

- Dedicated 4 (Four) Volumes
- Directional key for 8 (Eight) directions and center key for moving to the display center
- Dedicated 20 (Twenty) keys
- Available to select every function in Menu



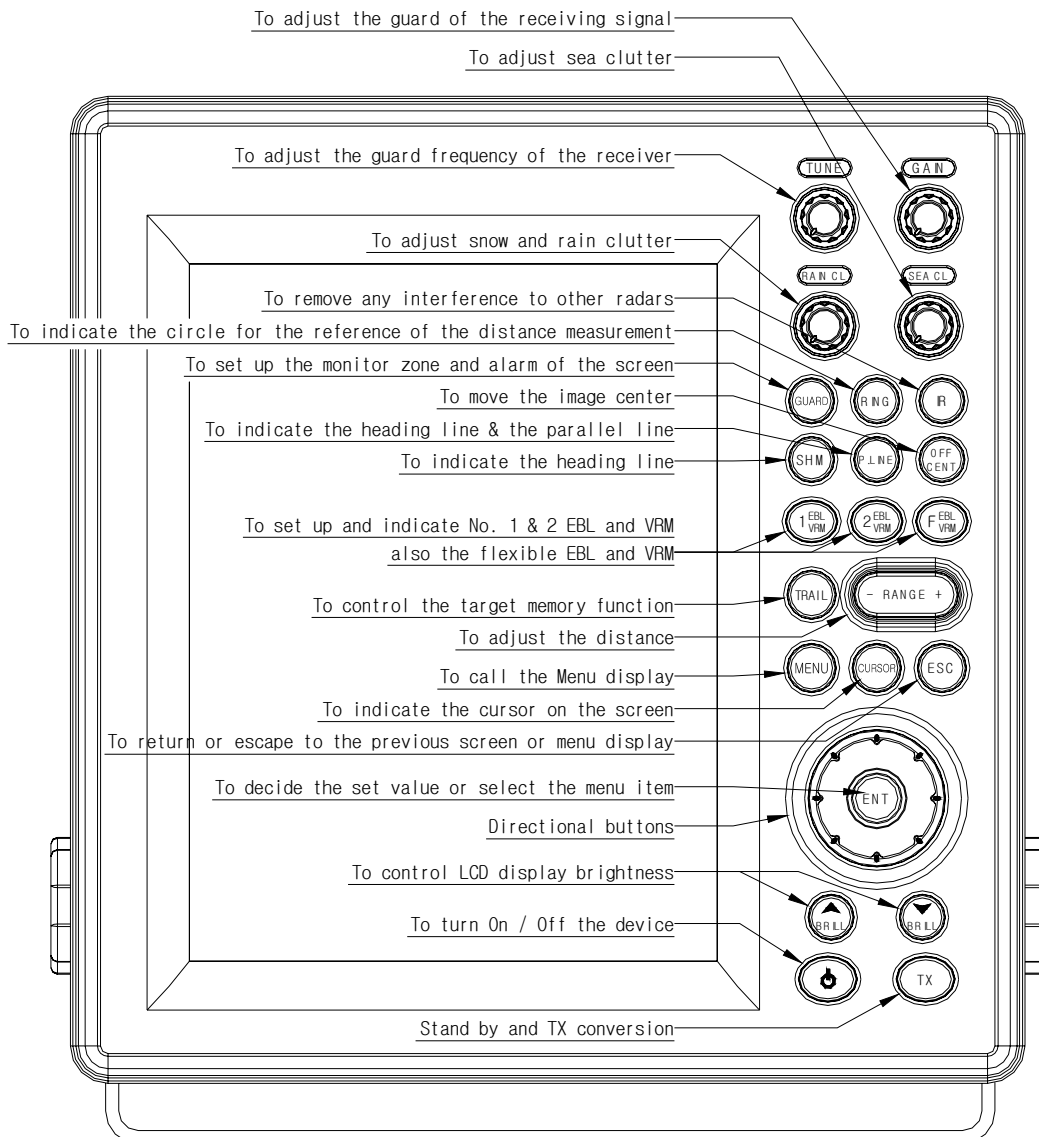





#### 2.1.1 Front & Knob Function



[Picture 2-1] Front Knob & othe Fron Button

### 2.1.2 Directional Key

They are used to move the cursor, turn the EBL, change the VRM size and move to any of the sub-menu. They are used to operate the following functions.

-  ⇒ To set up the alarm zone
-  ⇒ To set up the distance & bearing between parallel lines
-  ⇒ To set up the center movement point
-  ⇒ To move the cursor
- 
-  ⇒ To set up EBL/VRM
- 
-  ⇒ To move to the sub-menu

Following is how to operate the exclusive keys.

### 2.1.3 Display Description

Description	Position	Display Characters
ALARM	Right, Top	ALM1, ALM2
Interference	Right, Top	IR0, IR1, IR2
Sector Blank	Right, Top	BLANK
Auto Tunning	Right, Top	TUNE AUTO
Manual Tunning	Right, Top	TUNE MAN
Target Zoom-In	Left, Top	EXT1, EXT2
Waypoint Memory	Left, Top	W1, W2, W3, W4
Heading Display Mode	Left, Top	H-UP, N-UP, C-UP
Screen Zoom-In	Left, Top	ZOOM
Heading Bearing	Middle, Top	HDG
Gain	Middle, Bottom	GAIN
Rain & Snow Clearing	Middle, Bottom	RAIN CL
Sea Clutter Clearing	Middle, Bottom	SEA CL
Auto Gain	Right, Bottom	GAIN-A
Auto Rain & Snow Clearing	Right, Bottom	RAIN-A
Auto Sea Clutter Clearing	Right, Bottom	SEA-A

## 2.2 Display Description

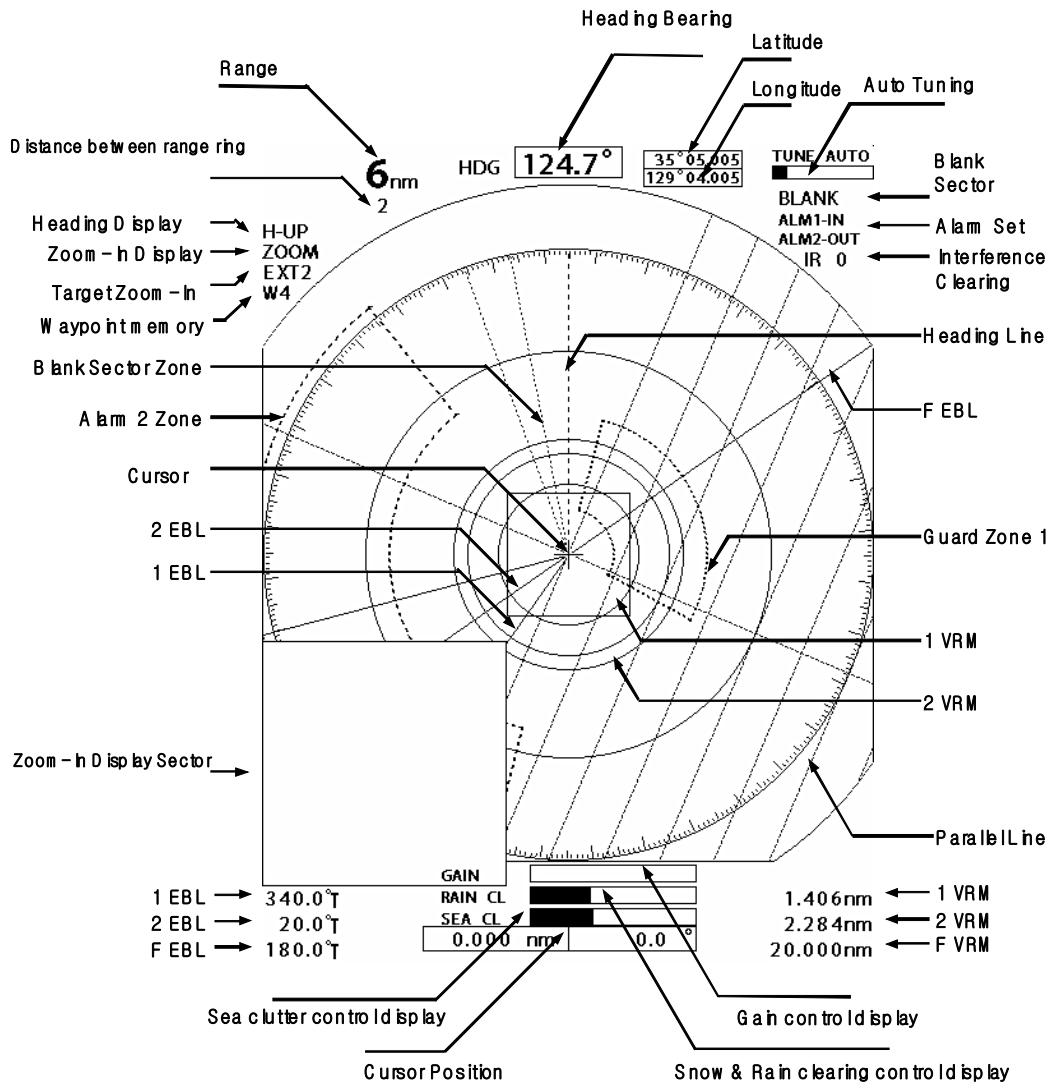

- The bearing, speed, latitude, longitude on the top of the screen and the destination setup on the right bottom of the screen are displayed only when the signal from Gyro and GPS is input data port.

## 2.3 Menu Functions

In addition to the functions used by the front panel keys, SMR-3700 has the functions to enable user to control with menu.

### 2.3.1 Menu Composition

It is available to converse the display language to Korean, English and other languages.

Press **MENU** and select any wishful setup menu by using direction button.

There are total of five (5) different menus and each menu function explained as following;

- ⊙ Echo Menu : Menu setting for the target display
- ⊙ AIS Menu : Menu setting for the AIS display
- ⊙ Display Menu : Menu setting for the display colors and other functions.
- ⊙ Comms (Communication) Menu : Menu setting for external devices and communication speed or usage.
- ⊙ System Menu : Sets languages and equipment's initial setting menu

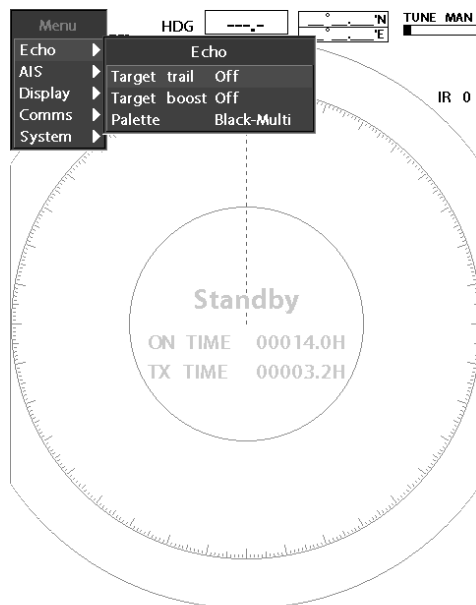

[Echo Menu]

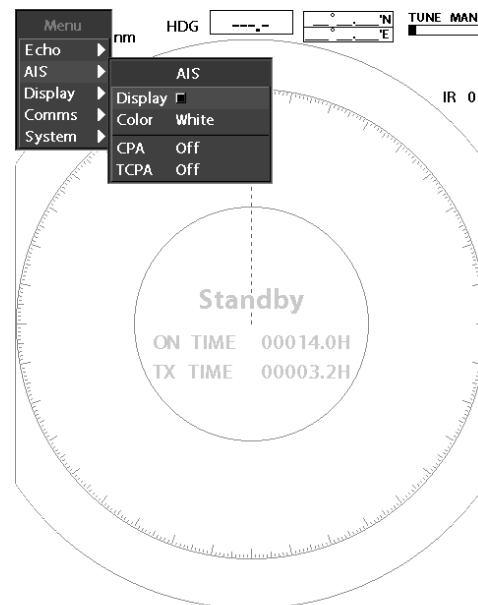

[AIS Menu]

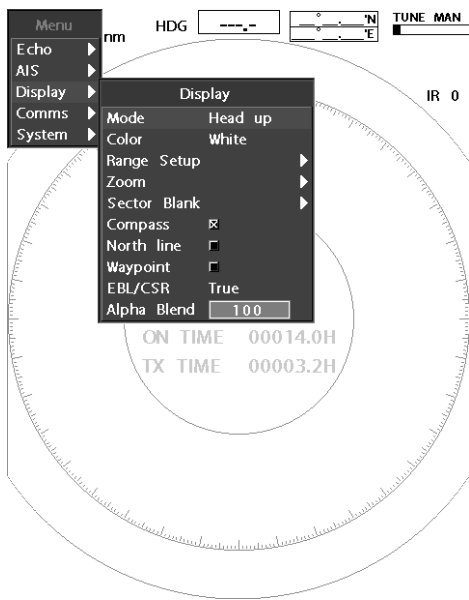

[Display Menu]

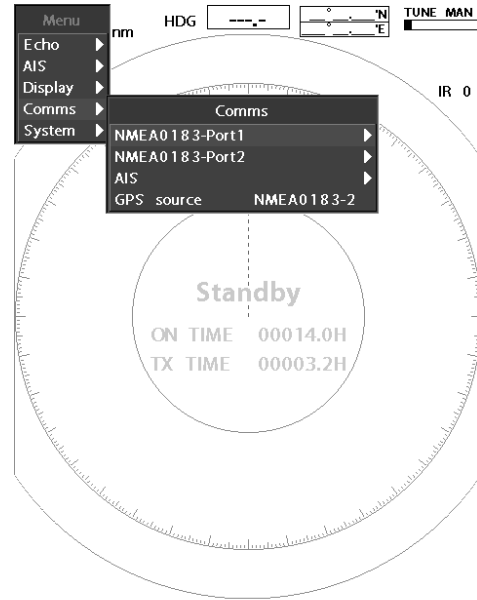

[Communication Menu]

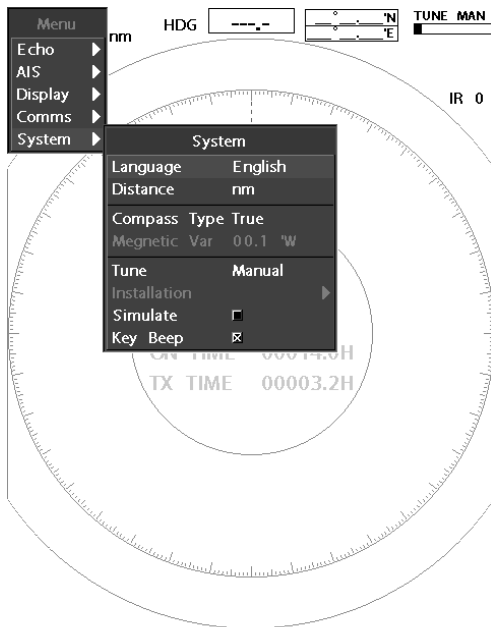

[System Menu]

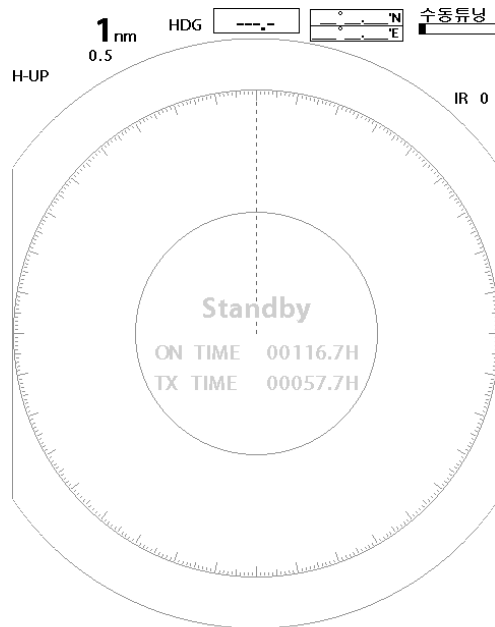

[Initial Display]

## 2.3.2 Menu functions

### 2.3.2.1 Echo Settings

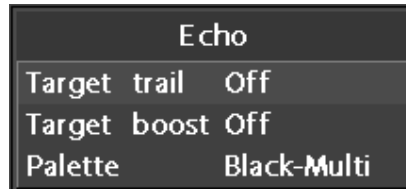

- **Target trail**

Target trail can be displayed by setting of the revolution number, and it can be displayed with target's moving status with different colors.

This function will operate by pressing **TRAIL**. Revolution can be adjusted from Off status then 1<sup>st</sup> to 4<sup>th</sup> revolution. Current setting status will be displayed on the left upper screen corner.

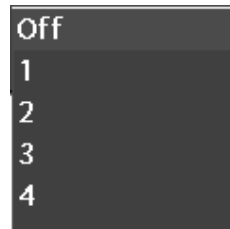

- **Target boost**

Set and adjust the target boost size with two (2) different levels.

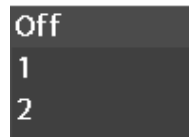

- **Palette Color Selection**

User can select a favorite color from one of five (5) different colors of the target.

Example) Black-Multi: Black background color with any color of target.



### 2.3.2.2 AIS Setting

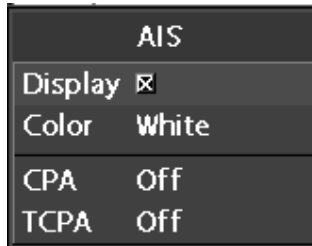

- **Display**  
Select either display of AIS or not.
- **Colors**  
Selecting a color of AIS target; you can choose Green, Red, Blue, White, or Black.



- **CPA, TCPA (AIS Alarm Setting)**  
Setting menu for the AIS' target wreck alarm of CPA distance set, TCPA is setting for approximate time of wrecking.

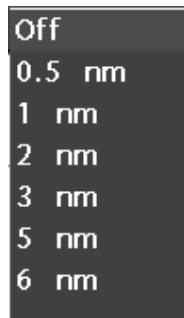

(CPA Menu)

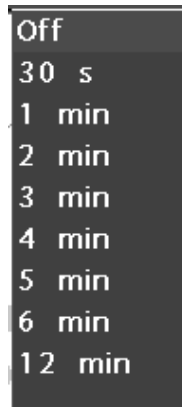

(TCPA Menu)



### 2.3.2.3 Display setting

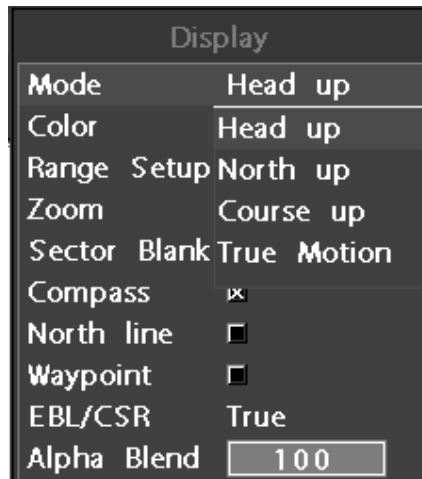

- **Mode**

This menu is available to display bow, N-UP, C-UP and True Motion. It's only available to display Bow mode when there is no external signal,

It is available to select N-UP, C-Up and True Motion mode when there is an external signal of bow

※ Course means the waypoint set externally

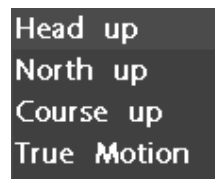

- **Colour**

It's available to select the colours between white, green, red for letters.



- **Distance setting**

You can set the distance unit from 0.0625, 0.125, 0.25, 0.5, 0.75, 1, 1.5, 2, 3, 6, 12, 24 to 36 but when 0.0625 is not available to use with km(kilometers) – mode.

- **Zoom**

This function is to zoom up and it's available to zoom up x 2 and display the left or right corner in the bottom of the display

There are two display functions, Cursor Lock and Cursor Float

Cursor Lock : Move cursor where you want to see and zoom up around the cursor.

Cursor Float : Zoom up the the cursor is.

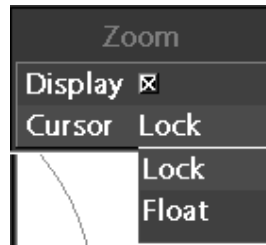

- **Sector Blank**

You can set Sector Blank in the radius 360° by 1 degree..

It will be displayed with blue broken lines.

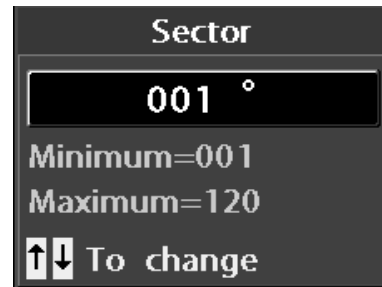
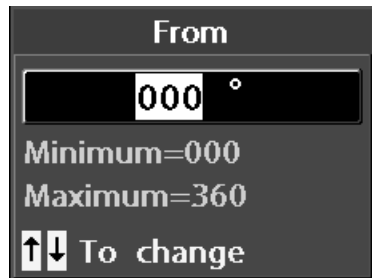
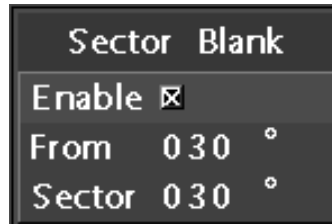

- **Compass**

You can turn on/off the compass function in the screen.

- **North line**

You can turn on/off the North line in the screen.

- **Way point**

You can turn on/off the way points from other equipment.

- **EBL/CSR**

You can select EBL/CSR to be Relative or True.

- **Alpha Blend**

You can set transparency of POP-UP menu between 50 to 100.

### 2.3.2.4 Communication setting

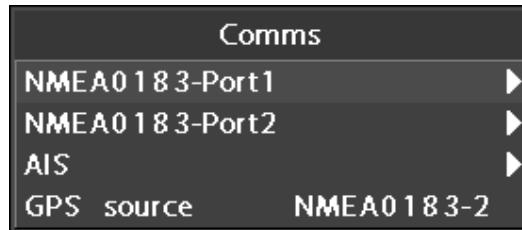

- NMEA0183-Port

This is a menu to set NMEA0183 port, you can check the transmission speed and communication status. It provides Communication speed at 4800, 9600 and 38400.

You can check the communication status of receiving signal from other equipment.

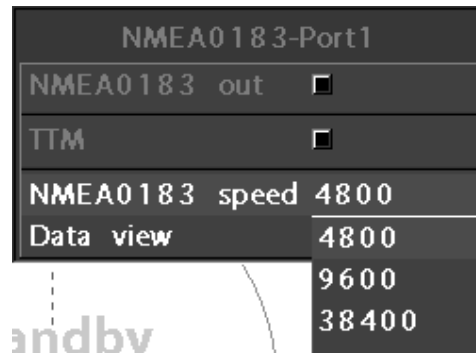

- AIS

A function to check the communicate condition to other equipment.

- GPS Input

A function to select GPS input port.

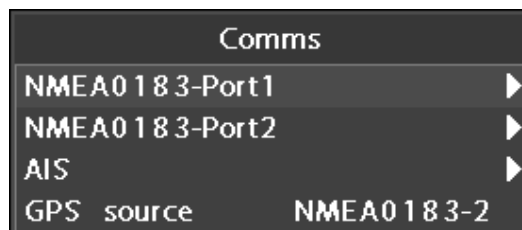

### 2.3.2.4 System setting



- **Language setting**  
Select a language what you use.
- **Distance measure**  
You can choose among nm, mi, km
- **Compass Type**  
You can select radar image with true heading or self heading.  
Self adjustment is to adjust information of self heading.

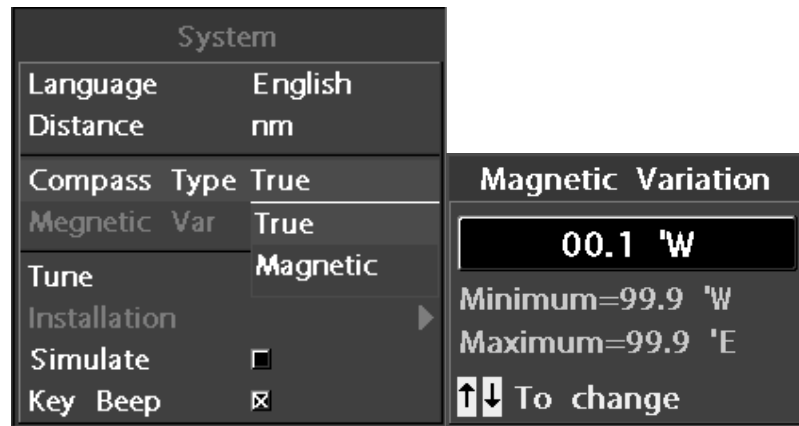

- **Tuning**  
You can set Auto/Manual a way of setting TX and RX.
- **Installation Setting**  
A function to set a equipment, please refer 5.6 article.  
※ It's not operated in the beginning, please refer 5.6.1 Initial setting menu to use this function.
- **Simulation**  
A function to check operation without scanner.
- **Key beep**  
You can turn on/off button beep.

## Chapter 3. How to operate the unit

### 3.1 General Idea



#### 3.1.1 Power input and Operation

##### 1. Power input

- To power on, press **POWER** button.
- After power on, Count Down Timer is displayed on SAMYUNG Logo screen, it is converted to the stand-by in 1 min. 30 secs.
- As the TX time is consolidated and displayed, user can judge the ideal time for repair..
- It indicates the version of the program..

[Refer] When it is not available to power off due to programme is down, please push OFF switch for 10 seconds so that you can turn it off by force.

##### 2. TX

- Press  button to enable the transmission at the stand-by status..
- Press  button again to convert the TX status to the stand-by status.

#### 3.1.2 Tuning control

It is required to control the tuning of the unit both manually and automatically.



The conversion is selectable in the setup of MENU.

For the automatic tuning, "Auto Tuning" is displayed next to the tuning bar.



##### 1. Change tuning mode

- **Menu** → **System** → **Tuning** → **Auto / Manual** → **Input** → **Return**

##### 2. Control tuning volume

- In case of the manual tuning mode, turn the volume to adjust the image biggest.
- Adjust the movement of the tuning bar biggest..
- In case of the automatic tuning mode, it is needless to turn the volume.
- If any image doesn't appear, adjust the volume again or turn the volume of  /  (rain/snow) removal.

#### 3.1.3 Image control

-  the volume of the tuning/gain of  (sea clutter),  (rain/snow), removal to display the optimum image.

### 3.1.4 Power off

1. Stop transmission(TX).

- Push **TX** key to be ready to transmit .

2. Turn off the Power.

- Push **POWER** key for 3 seconds then power will be turned off.

ex) The parts for power on are operating while power is offed so please disconnect power completely if you don't use this equipment for long.

## 3.2 Stand by for processing

### 3.2.1 Brightness change

- Press brightness key.

Push **▲** key to brighten the screen, push **▼** key to darken the screen.

There are 10 levels you can adjust.

### 3.2.2 Language Selection

- Menu → → System → Language → Select user's language → **Input** → **Return**  
Select language what user wants to use.

## 3.3 Basic Operation

### 3.3.1 TX

- Press **TX** button, it will be converted to TX from the stand-by status.

### 3.3.2 TX Stop

- Press **TX** button again at the TX, it will be the stand-by status.

### 3.3.3 Tuning Control

- Please refer to [3.1.2 Tuning Control].

### 3.3.4 Gain control

#### ATTENTION

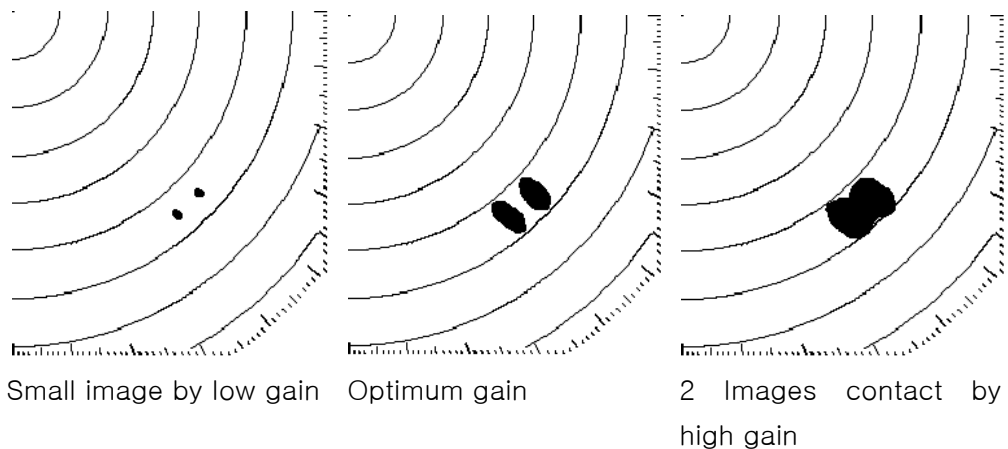

- ※ It should be always observed by adjusting the optimum conditions.
- ※ If the gain is too low, the targets may not be displayed.
- ※ If too high, it may be an obstacle in observation due to the noise increase on the display.

- Turn gain key.  
When you turn to left, decreasing the gain, when you turn to right, Increasing the gain.
- To adjust the optimum gain  
It's the maximum size of ECHO image by object, by object very closed, It's not contacted to ECHO image.



- Auto gain setting  
When you push the switch in the gain volume, it will be displayed AUTO in the centre of bottom of the screen, it will be displayed GAIN-A in the right corner of the bottom of the screen.  
This function is set the optimum environment without adjusting gain but there isa possibility to be some noise up to the environment.

### 3.3.5 In order to remove the interference of rain/snow

	<b>ATTENTION</b>
	<ul style="list-style-type: none"> <li>※ Too much adjustment of rain/snow removal will restrain the target of ships or hazards as well as any images by rain/snow. This can be the cause of image analysis.</li> <li>※ In case of use of rain/snow removal, the optimum conditions should always be set.</li> </ul>

- If much rain/snow, it is difficult to analyze the wishful target image as the echo by rain/snow clutter appears on the display.
- Turn Rain CL to the right to remove the echo image by snow and rain.

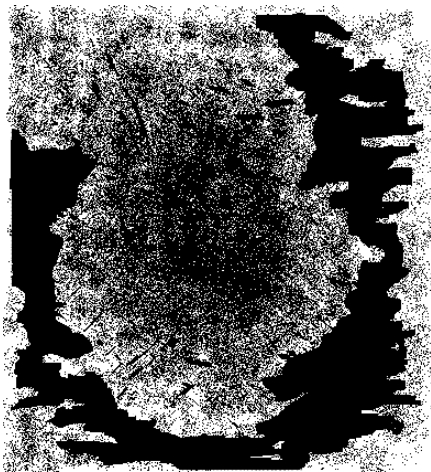

Reflected wave of rain/snow





Removed rain/snow  
(Target is restricted, too.)

- Auto setting rain/snow  
When you push the switch in the volume for removal rain/snow, it will be displayed AUTO in Rain CL in the middle of bottom of screen, it'll be displayed RAIN-A in the right corner of bottom of screen.  
This function is to make a best display setting without managing the removal snow/rain volume but please don't use this function when it doesn't need to manage removal rain/snow because this function makes target smaller than usual.



### 3.3.6 To remove the interference of Sea Level Wave caused by the Sea Wave

 <span style="font-size: 1.2em; font-weight: bold; margin-left: 20px;">ATTENTION</span>
<div style="display: flex; align-items: flex-start;"> <div style="margin-right: 10px;">  </div> <div> <p>※ If you set the removal function of Sea Level Wave up to removal of all Sea Level Reflection at short distance, it causes interference in detecting images due to the target of vessel and dangerous things as well as the wave images being suppressed.</p> <p>※ When you use the removal function of Sea Level Wave, you make sure it should be the optimistic set of suppression</p> </div> </div>

- When the wave becomes high due to heavy wind, the ECHO(Sea clutter) due to the wave is displayed on the screen, then it will be difficult to detect the image of the target.
- Turn Sea Clutter key to the right to remove the echo image by wave.

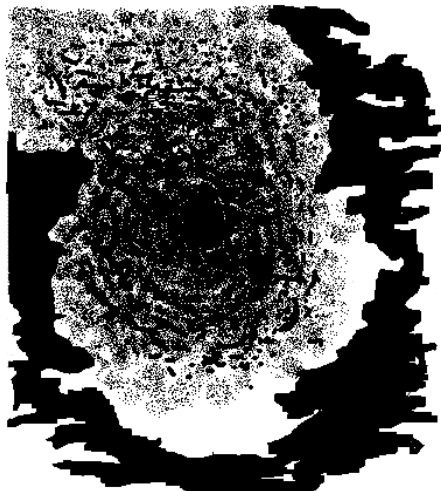

The status that shows Sea Level Reflection is strong due to Wave.

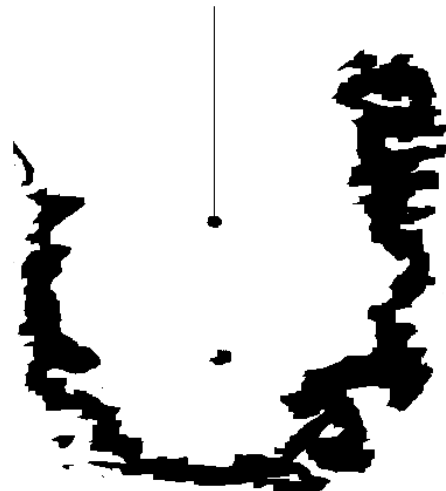

The status that shows Sea Level Reflection is being suppressed.

(The target is also suppressed)

- Auto Sea Clutter removal setting

When you switch on Sea Clutter remove, it will be displayed AUTO in the Centre of bottom of screen, it will displayed SEA-A in the right corner of bottom of the screen.

This function is automatically set the optimum function for display.

But it is not necessary to set this function when you don't need to remove Sea Clutter because the target will be small.

### 3.3.7 To operate the alert function

- Set the guide zone in order to use the alert.
- Guard Zone means [Zone] to be set on PPI screen

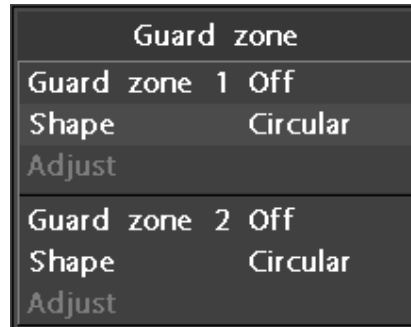

#### 1. Guard Zone Setting

- Locate the cursor where you want to move
- Press the **Alert** key
- POP-UP Menu will be appeared to set up two different guide zones on the screen
- Select incursion or separation of guide zone.
- Incursion means the target enters into the zone and separation means the target come out of the zone. In each case, the alert sound will come out
- Select Ring or Fan  
Ring function will create ring-shaped guide zone and Fan function will create Fan-shaped guide zone.
- Press Adjust and then move the cursor to set up the guide zone.
- Press the **input** key.
- After a desired guide zone is done then exit

#### 2. Occurrence and Stoppage of the alert sound

- After setting up the guide zone, the alert sound will come out once the target enter into the zone.
- To stop the alert sound, press any key on the device.

#### 3. Termination of the alert

- To terminate the alert status, press the alert key and then select the alert zone off.

### 3.3.8 To eliminate/display the scale of Range Ring

#### 1. Press the Range Ring Key

- The brightness of ON/OFF will be adjusted.

### 3.3.9 To eliminate the radar interference

#### Caution

- ※ When using the function of Interference Removal, weak image such as a dangerous thing may happen to be removed.
- ※ Stop the function of interference removal when you see Radar BEACON an SART signal.

Radar Interference means Microwave transmitted by other ship's Radar is displayed on PPI screen, which is directly affecting to own ship's Radar air line.

#### 1. Press the interference removal key

- Whenever pressing  button, it marks with IR-1, IR-2, IR-3 in order in the top-right screen.

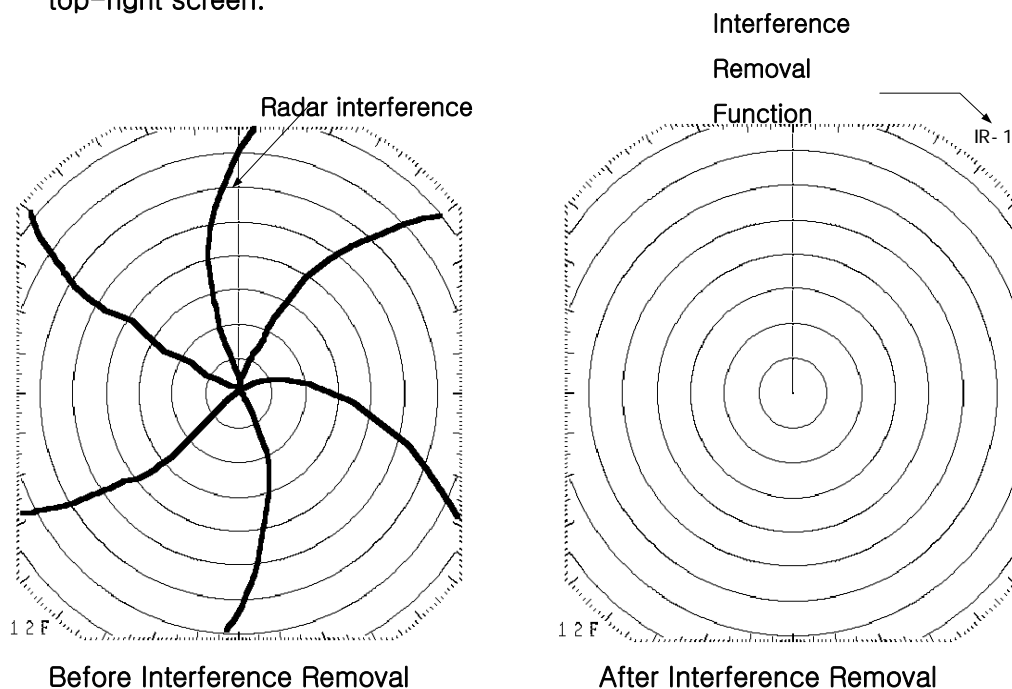

### 3.3.10 To change the color of the ship's heading line.



#### 1. Press the ship's heading line key

- Ship's heading line is indicating own ship's heading direction.
- When the key is pressed, the brightness will be adjusted in 3 different degrees.

### 3.3.11 To use the parallel line

#### 1. Press the parallel line key

#### 2. To adjust the distance and the bearing, use the diagonal key as follows:

-  key can adjust the bearing of the parallel line.
-  key can adjust the distance of the parallel line.

### 3.3.12 To move the center of own ship

It can use for securing the wider sight to the specific direction from the center of own ship.

#### 1. Move the cursor to a desirable position.

#### 2. The center of own ship moves to the position of the cursor by pressing center movement.

- It can be moved up to 60 percent of the screen.

#### 3. Once center movement key is pressed, it will turn back to the original position.

### 3.3.13 To measure the distance and bearing to the target.





Method 1. By using **EBL/VRM**, the distance and bearing of target can be measured.

EBL means Electronic Bearing Line.

VRM means Variable Range Maker.

Method 2. By using cursor, the distance and bearing of the target can be measured.

#### 1. Measurement of the distance and bearing by using **1 EBL/VRM**

- Press the **1 EBL/VRM** key.
- VRM & EBL are shown at the center of the screen
- By pressing  , it can move the EBL.
- By pressing  , it can move the VRM.
- Distance/Bearing value appears on the bottom of the screen.
- To exit, press ESC key.

#### 2. Measurement of the distance and bearing by using **2 EBL/VRM**

- The method will be same as 1 EBL/VRM.

### 3. Measurement of the distance and bearing by using **F EBL/VRM**

- Press the **F EBL/VRM** key.
  - EBL/VRM will appear on the radar screen.
  - Once the cursor is appeared, move to the desired position.
  - By pressing **Center Movement** key, the center of F EBL/VRM will be shifted and will be back to the original position by repressing the key.
  - By pressing cursor, cursor will be disappeared and then use the direction key to move EBL/VRM to the desired position.
  - The value of distance and bearing will appear on the bottom end of the screen..
  - To exit, press the esc key.
- [Ref] F EBL/VRM can be used to indicate EBL/VRM on the specified position.

### 4. Measurement of the distance and bearing by using **Cursor**

- By using **Cursor**, cross shaped cursor will be appeared on the radar screen.
- The value of distance and bearing will appear at the bottom end of the screen, where the cursor is located.



### 3.3.14 To change the distance uni

#### 1. NM (Nautical Mile)

**Menu** → **System** → **Distance unit** → **Input** → **NM** → **Input** → **Esc**

- Cursor, VRM, Distance of parallel line represents NM.

#### 2. Mile

**Menu** → **Sytem** → **Distance unit** → **Input** → **Mi** → **Input** → **Esc**

- Cursor, VRM, Distance of parallel line represents Mi

#### 3. Kilometer (Km)

**Menu** → **System** → **Distance unit** → **Input** → **KM** → **Input** → **Esc**

- Cursor, VRM, Distance of parallel line represents KM.

### 3.3.15 To change the way of direction symbol

#### 1. Indication of ship's head line (H-UP)

**Menu** → **Indication** → **Mode** → **Input** → **Head** → **Input** → **Esc**

- Ship's head is displayed to the HEAD UP.
- If ship's head is changed, ECHO image bearing on the screen is also changed.
- If you could not obtain bearing reference from external navigation equipment like **Gyro Compass**, it sets out with this bearing display.

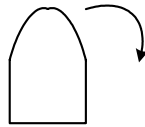
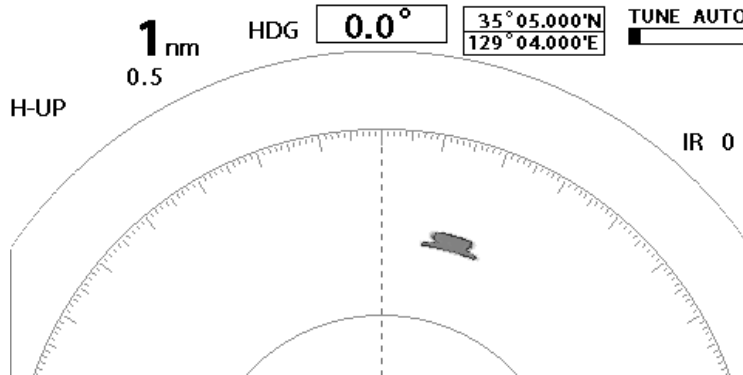

When the own ship turn right to 45 degree

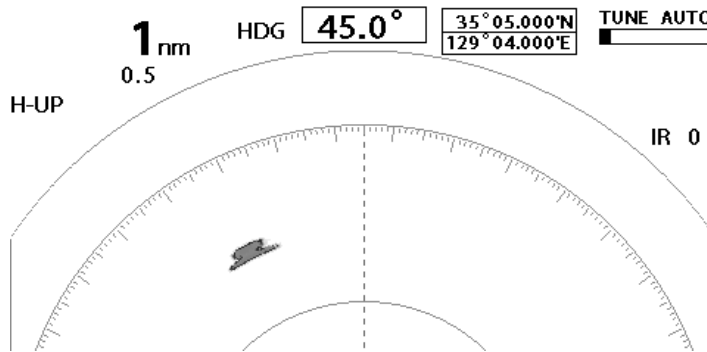
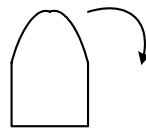
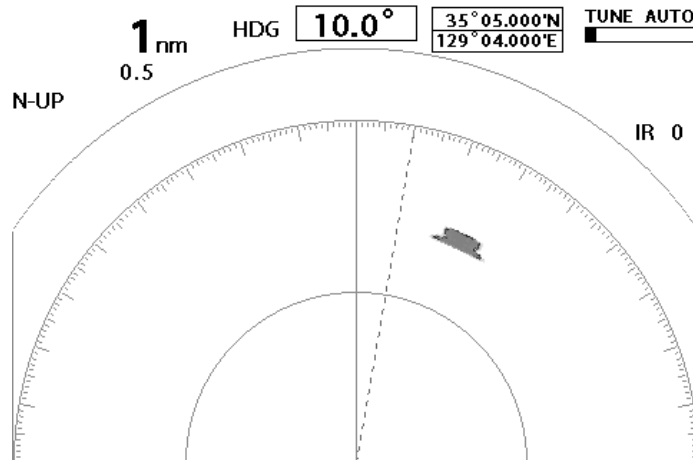

Image moves to the left.

## 2. Indication of North direction

**Menu** → **View** → **Mode** → **Input** → **North** → **Input** → **Esc**

- The vertical line will indicate the direction of the North, the line to 10 degree indicates the ship's heading line.
- The angle of bearing will be changed based on the North direction on the screen.
- It requires the equipment like **GYRO COMPASS** to obtain bearing information.



When the own ship turn right to 35 degree.

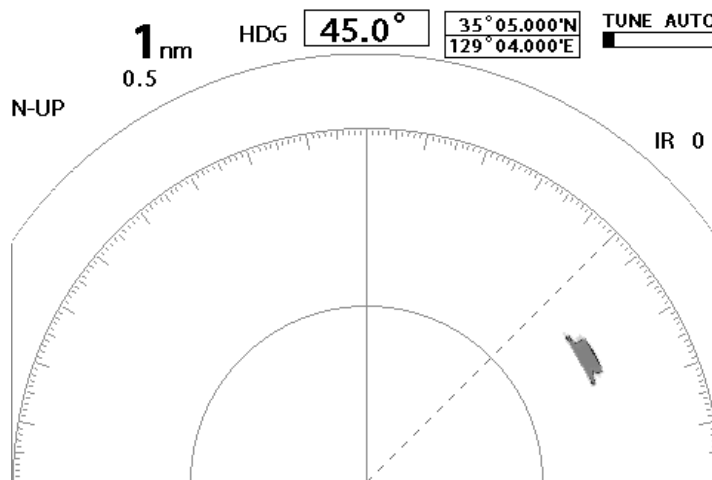

Ship's heading moves to the right.

### 3. Indication of course-up (C-UP)

**Menu** → **View** → **Mode** → **Input** → **Course** → **Input** → **Esc**

- Make the ship's head line on the screen when the course-up is executed.
- Even though ship's head direction is changed, Echo image bearing moves as much as the variation of ship's heading bearing.
- When you change the track widely, set the course up again from the MENU.
- It requires the equipment like **GYRO COMPASS** to obtain bearing information.

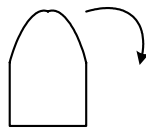
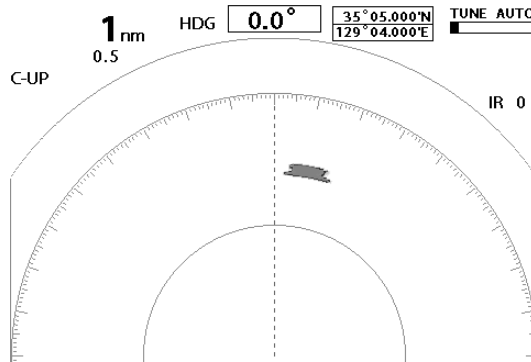

When the own ship turn right to 45 degree

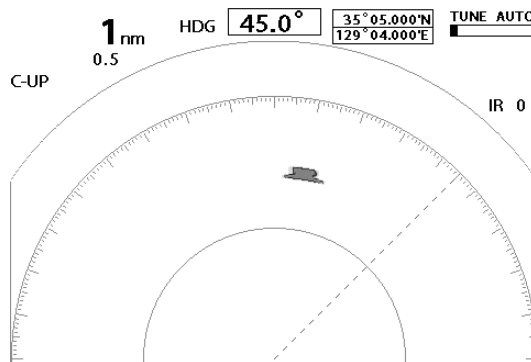

Head Line moves to the right.

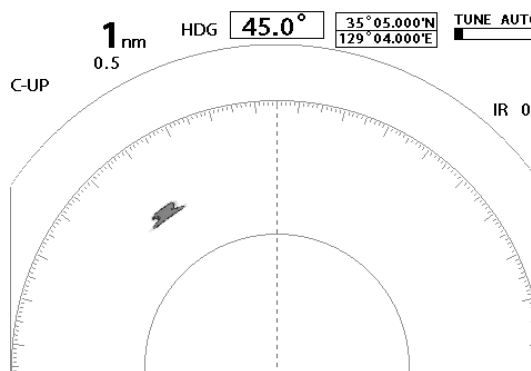

When the course up is reset



### 3.3.16 To change the way of bearing display

#### 1. True Bearing

**Menu** → **System** → **Bearing Display** → **Input** → **True Bearing** → **Input** → **Esc**

- True bearing indication is set based on true north with scale 0.
- It requires the equipment like GYRO COMPASS.

#### 2. Magnetic Bearing

**Menu** → **System** → **Bearing Display** → **Input** → **Magnetic Bearing** → **Input** → **Esc**

- Magnetic Bearing indication is set based on Magnetic North with Scale 0.
- MAGNET COMPASS is needed.

### 3.3.17 To change the way of displaying bearing line/cursor.

When you display the value of EBL bearing, select between the own ship and True North as a base.

#### 1. 'Relative' Indication

**Menu** → **View** → **EBL/Cursor** → **Input** → **Relative** → **Input** → **Esc**

- Make the cursor, and the bearing value of EBL indicate based on ship's heading line (Ship's head line is 0)

#### 4. True North Indication

**Menu** → **View** → **EBL/Cursor** → **Input** → **True North** → **Input** → **Esc**

- Make the cursor, the bearing value of EBL indicate based on True North (True North is "0")

### 3.3.18 To compensate the magnetic

Enter the value of compensation because Magnetic North Bearing is slightly different according to the navigation zone.

**Menu** → **System** → **Magnetic Compensation** → **Input** → Enter the value by cursor → **Input** → **Esc**

- Enter the value manually.
- Enter the value using direction key.(99.9 'W ~ 99.9 'E)
- Direction key will shifted by  $\pm 0.1$  with  $\uparrow \downarrow$  and  $\pm 1.0$  with  $\leftarrow \rightarrow$ .

### 3.3.19 To display the trace of the target.

- It can ascertain the other ship's movement in track line distance and direction and it facilitates to avoid collision of the ship.
- The longer target track line is displayed, the faster the other ship's speed is and vice versa.
- The length of the track line is displayed ranging from 1 to 4 cycles.

#### 1. Activation of the target trace

**Menu** → **Echo** → **Target trace** → **Input** → **1~4** → **Input** → **Esc** or **TRAIL**

- The revolution of the scanner will be displayed from 1 to 4 cycles.
- The color of the target track line will be changed in each cycle.
- On the upper left side of the screen, the status (W1~W4) will be displayed.

#### 2. Deactivation of the target trace

**Menu** → **Echo** → **Target Trace** → **Input** → **OFF** → **Input** → **Esc** or **TRAIL**

### 3.3.20 To display ECHO image wider on the radar screen.

#### Caution

※ When designating the target magnification and wider transmit pulse width, the images over two targets accessed from fore and after direction and angle direction.

To expand the ECHO image, use the following steps

- Use the function of the target expansion.
- Set the width of TX Pulse long.

#### 1. Activation of the target expansion

**Menu** → **Echo** → **Target Expansion** → **Input** → **1~2** → **Input** → **Esc**

- The size of the target on the screen will be doubled.

#### 2. Deactivation of the target expansion

**Menu** → **Echo** → **Target Expansion** → **Input** → **OFF** → **Input** → **Esc**

- It will turn back to the original status,

### 3.3.21 To change the color of the radar screen and ECHO image.

#### 1. Configuration of the color of ECHO image and background.

**Menu** → **Echo** → **Color Selection** → **Input** → Choose the color → **Input** → **Esc**

- On the bottom left of the screen, color level will appear.
- During the night navigation, make background color dark and set the LCD brightness to the low level, it will help relieving eye's fatigue.

### 3.4 Connection to the external navigation equipment

- At the rear side of the indicator, connect to the external navigation equipment through data terminal.

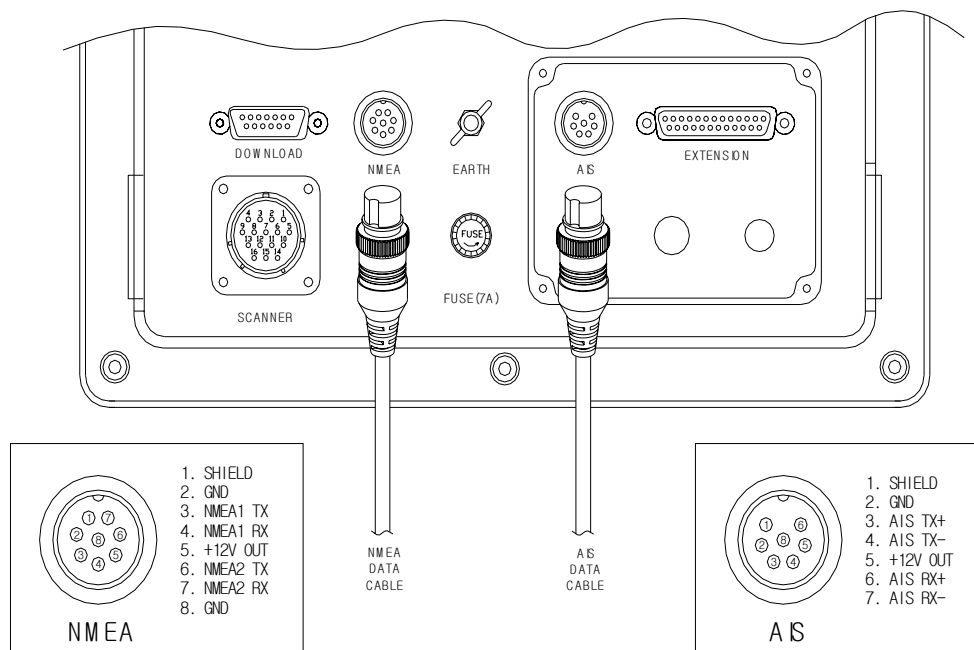

## Chapter 4. Screen view

### 4.1 The distance from the target to the height of target

The longest distance observable to the target is depending on the height of target, the distance to the target and the height of antenna other than the matter of performance like Tx power, Antenna beam width and receiving sensitivity. Radar signal is linear nature that is not affected by a round earth.

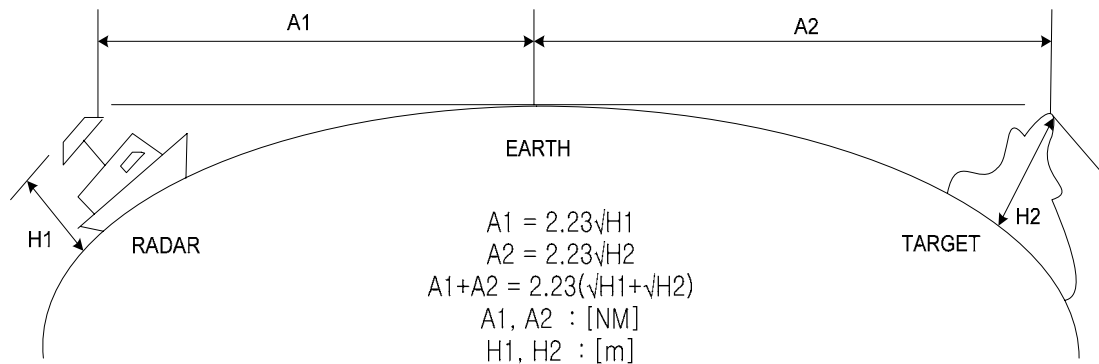

For example, when the height of antenna is 3 meters above sea level, the ECHO image of island of 10 meters' height and 10 miles away from the antenna can be displayed on Screen but the 5 meter's height with same distance is not displayed on screen since Radar signal transmitted does not reach.

But, these are of theoretical value and would not be constant due to environmental condition. In theory, the target 10 miles away from the antenna requires 7.6 meters' height, if it is lower than 7.6 meter, ECHO image would not appear for which you must keep in mind.

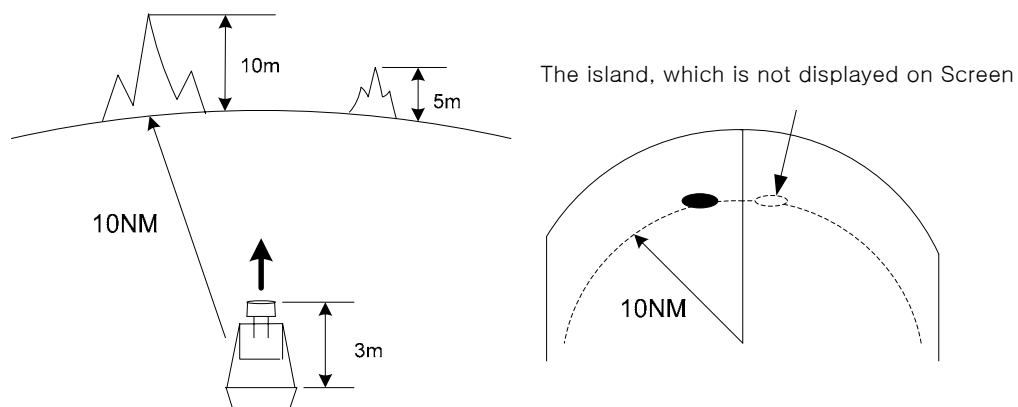

## 4.2 Reflection from the target

- The strength of reflection from the target is related to not only the size of the target but the shape of the materials composed of it, therefore the strength of reflection is not considered to be relative to the size of the target.
- Especially it is dependant to the geographical condition in coastal line. If the coastal line is flat slide, the only mountain summit is displayed on the screen as an image, you should pay attention to the calculation of distance upto the coastal line.
- The ECHO reflected from flat land is so weak that it is unlikely to observe such land.

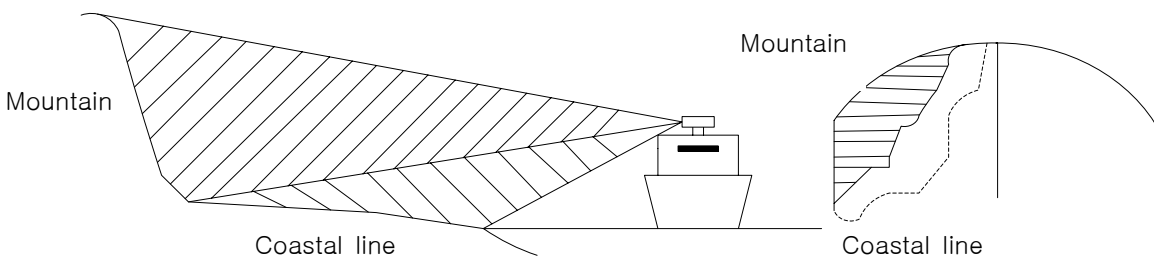

## 4.3 Wave Path

- In case there is an obstruction in the course of wave path like Mountain, Rain and Snow, the target behind of them may not be observed.

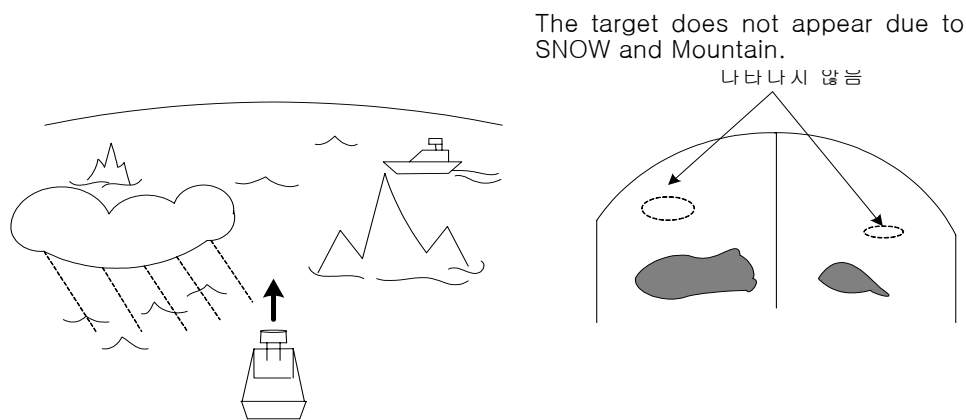

### 4.3.1 Reflection of sea level

- On the sea surface where are made, white and broad images are displayed on the screen center. This is a reflection created from the sea level and occurs as a different image mainly depending on the size of save, range and the direction of wind.

### 4.3.2 False Image

There is a possibility that non-existing targets may be shown or any existing targets may not be shown through the image. This image is called 'virtual image'. What mainly causes such false image as follows;

#### 1. Shadow

Dipending on the installation position of antenna, the reflection may come back after colliding against the funnel or mast, which may create 'shadow' causing the virtual image on PPI screen. In this case, the targets that are located at the shodow direction may not be shown on the screen.

The existence of such a 'shadow' can be figured out by checking if there is any dim image or any unseen part, based on the reflection of sea level.

If the 'shadow' occurs, the user needs to memorize the direction in order to observe the targets with care.

#### 2. Side echo

There may be an image of arc wave line in the same distance from target image on the screen. This is caused by the side lobe of which beam is radiated from the antenna.

For this phase, it is easy to make a judgment when targets are fixed.

#### 3. Secondary reflection

Fake images may be displayed as their directions are changed through being reflected against the funnel or mast, which create shadow.

In this case, the images of targets are located at the mast direction that reflects the radar wave.

#### 4. Multi-reflection image

Where there are any structures or big-sized vessels that are hidden behind gigantic vertical line, multiple images by multi-reflection appear.



These images come out at intervals of every lamp line and among the lines, the closest line to the own ship is the actual image of target.

#### 5. Radar interference

If there is any radars closely located that uses the same frequency, the interference image by the radar appears on PPI screen. This interference turns into various spots and appear in forms of many images but as the interference does not appear in the same place, it can be distinguished from target image.

For the radar interference(, button), select 『ON』 in the function to diminish or get rid of it

## Chapter 5. Installation



	<b>CAUTION</b>
	<p>*The specialist from Head Office or Local distributor should carry out installation work.</p> <p>* Installation works carried out by unauthorized person can cause out of order, performance failure Electric shock.</p>

### 5.1 Overview

- Proper installation of Radar ensures the performance and safety of it during operation and facilitates the maintenance and repair of it, you should carefully pay attention to the proper of installation according to the instruction.
- Antenna should be installed as high as possible after considering its weight.
- Indicator should be installed inside Wheel House in order to make observation efficiently.
- 15m standard cable should be used between Antenna and Indicator.

### 5.2 Installation of Antenna

#### 5.2.1 Selection of the installation place

	<b>Caution</b>
	<p>※ The place where there is no big obstructions on the level of ship's fore and afterside.</p> <p>※ If there is an obstacle on the same level of Antenna, it may cause a virtual image.</p> <p>※ Especially when the virtual image appears on ship's fore and after side, it will be difficult to observe and hardly forecast the danger.</p> <p>※ The place where there is a near Funnel can cause the decrease in performance, the defect due to height, therefore it should be installed away from such Funnel as far as possible.</p> <p>※ Please keep in mind that Direction finding Antenna and VHF antenna should be far away from Radar Antenna.</p> <p>(Please avoid the situation from tying up said cables with Radar one)</p>

## 5.2.2 How to install Antenna

### 1. Take a caution when antenna is installed on High Speed Vessel

Generally the head of High Speed Vessel will be up float when ship is in full speed.

Due to

this, in case the Antenna being installed in even level and trim (angle of ship's stem while running) being over 1/2 of vertical beam width ( $\theta$ ), the Echo from this target is hardly displayed as image because the front of the ship is off the beam range that causes the electric wave reflecting from the target becomes weak. In opposition, at the stern of the ship the wave reflecting from the sea surface becomes strong. It will not affect the image at the port and starboard side of the ship.

Therefore, in case the ship that of trim is over 1/2 of vertical beam width ( $\theta$ ), it is recommended to install the Antenna in slant toward the ship's stem.

### 2. Caution while the Antenna is installed in Yaucht

It is apt to be sliding in slant toward the counter windy side while the yaucht is navigating when the wind is blowing to the extent. In case the slanted angle being over 1/2 of beam width, the electric wave reflecting from the target becomes weak since the ship structure is off the range of beam and Echo from this target is hardly displayed as an image. In opposiiton, the opposite side of the wind, surface reflecting becomes strong since the electric wave contacting sea surface becomes strong. It will hardly affect the images of fore and after side of ship.

Therefore, in case Yaucht that of slant is over 1/2 of vertical beam width ( $\theta$ ), it is recommended to install the mounting bracket in order that antenna can be slanted in right and left side according to the angle of slant.



## 5.2.3 Connection to Equipment Cable

### 1. Scanner (RSU-3700)

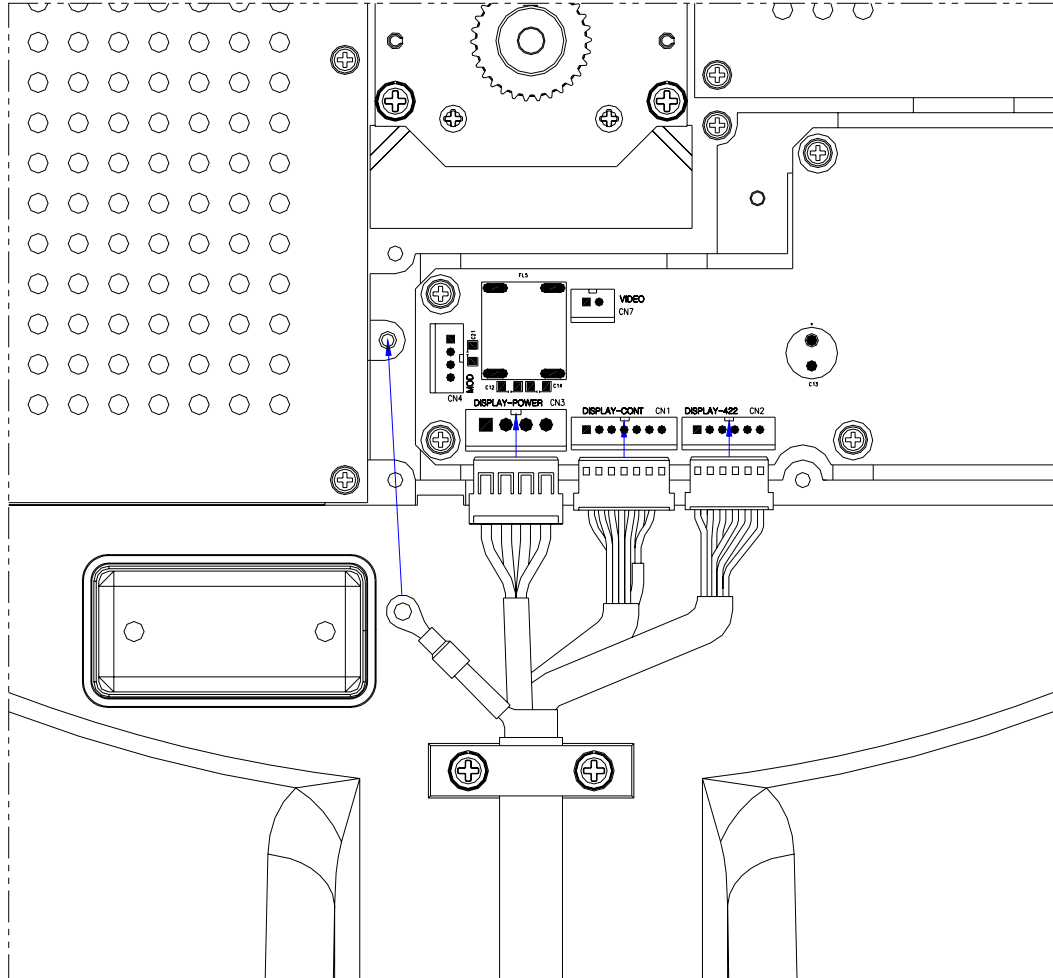

### Caution

※ Don't bend the connector too much when input the cable into the Radome for preventing from the damage

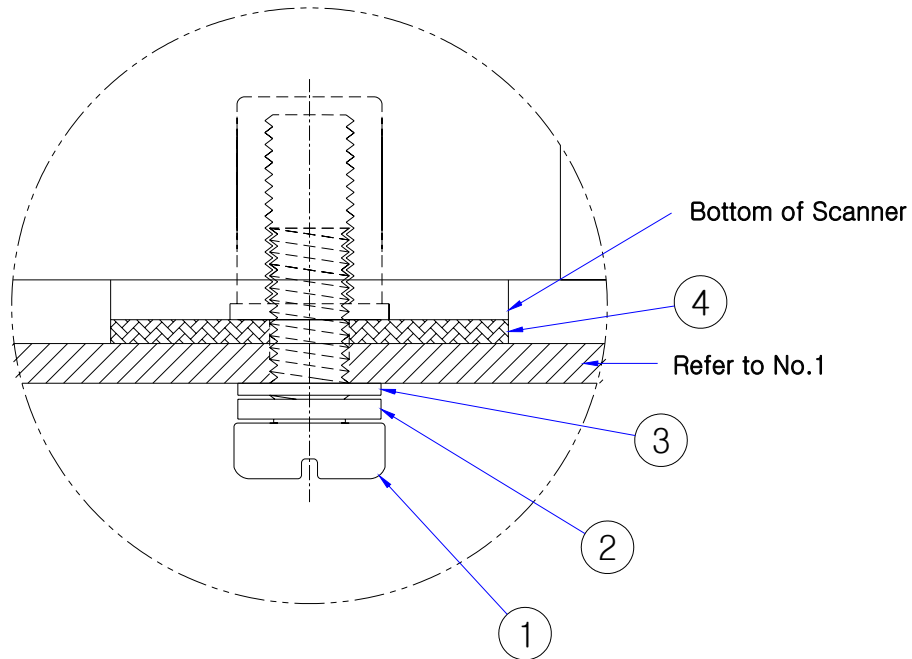

① Hexagonal Bolt (  $\Phi 10 \times 25\text{mm}$  )

② Spring Washer (  $\Phi 10$  )

③ Plain Washer (  $\Phi 10$  )

④ Rubber Pad for fix-up a radome

Refer to No.1: Use less than 5mm in a radome fix-up panel.

In case of over 5mm, hexagonal bolt should be changed for installation.

## 5.3. DISPLAY SET-UP

### 5.3.1. Location for installation

	<b>ATTENTION</b>
<ul style="list-style-type: none"><li>※ A display must be installed far away over than 1 meter from a magnet compass.</li><li>※ It may be harmful to the magnet compass in case of closer installation.</li></ul>	

- Select the location for easy-investigation and maintenance.

### 5.3.2 How to Install

- (1) Install the display according to the Block Diagram.
- (2) Refer to the installation diagram.

### 5.3.3. Power Cable connection

- (1) Connect a Power cable to **[POWER]** of the back-panel.
- (2) Connect an Aircable to **[SCANNER]** of the back-panel.
- (3) Connect an earth cable to **[EARTH]** of the back-panel.

## 5.4. Installation check

- After installation, check weather the condition is O.K based on the instruction. The serious check points are the cable connection, tight connection of each units, aircable, the connection of cable shield.

## 5.5. Operation check

- (1) Before the operation check, it needs to check if the internal voltage is in an acceptable voltage range.
- (2) Check all parts of the radar in detail after operation check.
- (3) Readjustment should be according to the manual even though the operation check is O.K.

## 5.6. Initial Installation

- In case of a first time, it must be executed an initial adjustment.

### 5.6.1 Initial Installation

Following is how to go to Initial setup menu

**Menu** → **System** → **Int. Set** → **Enter** after press these keys will show following display.

Installation	
Zero bearing	000 °
Zero range	15
Video ADJ	14
MBS ADJ	00
Tune ADJ	12
MT-RPM ADJ	20
Stc Curve	1
SW upgrade	
Setting	
Factory Reset	

※ Installation menu activate procdure:

At **Menu** in **System** list, press **Cursor** **중심이동** **Cursor** **중심이동** keys within 5 seconds then following screen will show:

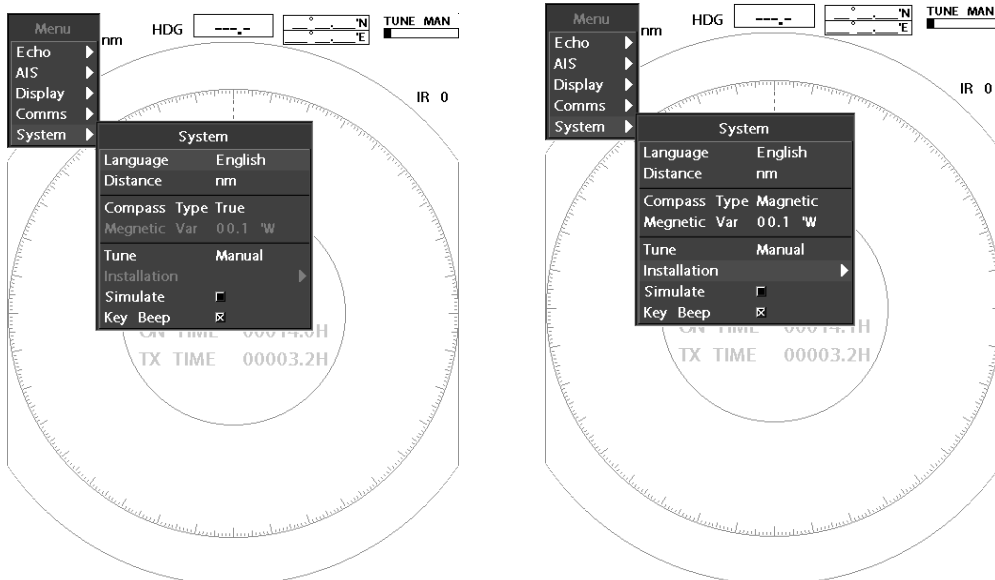

[Screen before activation of installation menu] [Screen after activation of installation menu]

## ATTENTION

※ The initial-setting should be executed in transmitting condition.  
Without the initial setting, the target mark, distance and direction may be wrong.

### 5.6.2 Bearing Adjustment

After installed the scanner, you can adjust vessel's heading/bearing degree from 0 ° to 360 ° degrees, and change it by 1° degree.

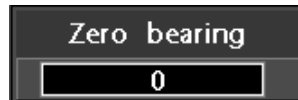

### 5.6.3 0 Mile Set

After installed the scanner, it depends on cable and/or device you can adjust a real distance and target distance by adjusting 0 Milet Set menu. Control level is divided by 36 different levels.

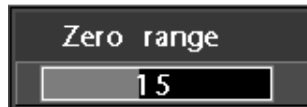

### 5.6.4 Video ADJ

After installed the scanner, it depends on calbe length video singal can be adjusted and control level is divided by 36 different levels.



### 5.6.5 MBS (Main Bang Suppression) ADJ

It may be Main Bang phenomenon in a center of the indicator in a short range and can be adjusted by 36 differenet levels. If value is increased then Main Bang phenomenon frequency will decrease.



### 5.6.6 Tune ADJ

On the front, there is key control knob for Tuning and can be adjusted by 64 different levels.

For setting procedure, make Tune VR to the center and set target object and Tune knob to the maximum.

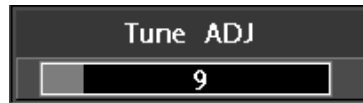

### 5.6.7 MT-RPM ADJ

This is how to set for the scanner's motor RPM.

Motor rotation will display with RPM measurement, normal operating rotate per minute is 24 RPM.

**ATTENTION)** When you operating in high speed then targeting object accuracy will decrease and system speed can be decrease.



### 5.6.8 Software Upgrade

This menu will upgrade previous software program.

### 5.6.9 Default manufacturing Setting

This menu will reset the default manufacturing settings.

**ATTENTION)** This menu is limited to use by end-users.

### 5.6.10 Default basic manufacturing set-up

This menu will reset device to basic set up from the manufacturer.

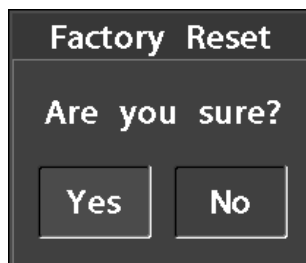



**ATTENTION**



Device came out with fully adjusted. For resetting for default basic manufacture is limited to end-users. Not recommending for adjusted by end-users all the time.

## Chapter 6. Maintenance

### 6.1. General Maintenance

- (1) In order to get Radar performed in good order, a periodical maintenance should be done properly.
- (2) The unexpected troubles would be less by paying proper attention to timely maintenance.
- (3) A common maintenance for each component is as follows.

#### 6.1.1. Cleaning

- (1) Do cleaning out the dust, salt water adhered to the unit.
- (2) Cleaning with dry cloth.

#### 6.1.2. Check out the tightness of screw, bolt

- Check the tightness of screw or bolt, which attached on the unit.

#### 6.1.3. Check the cabling

- Check and maintain the cabling between units periodically. (Scanner–Display, Display–Power, Display–Option).

<b>ATTENTION</b>
------------------

- |  |
|--|
| <ul style="list-style-type: none"> <li>※ In case of the check of units, please make sure to turn off the power to protect from electric shocking.</li> <li>※ In case of using rectifier, cut off the power on monitor because it is still excited even Radar stopped.</li> </ul> |
|--|

### 6.2. Scanner

- When maintained a wireline, cut off the power of monitor and then protect the power supplied into the wireline. Don't place watch or electronic card to the area of modulation, which equips with Magnetron.

#### 6.2.1. Radom

- (1) In case Radome surface being contaminated by dust, paint, it may arise the attenuation or reflection of electric wave and cause to decrease the performance of Radar, it should be cleaned out by a soft cloth with alcohol to keep it cleaned at all times.

<b>CAUTION</b>
----------------

* Don't use Benzene, Gasoline, Tricrene, Keltone and any solvents other than alcohol.
--

(2) Check periodically the tightness of the attached bolts.

### 6.2.2. Bracket

- Check the mounting of scanner and do painting every half-year to prevent from being rusted.

## 6.3. Display

### 6.3.1. Cleaning of a Display Screen





- (1) In case a stain adhered to LCD screen, it deteriorates the transparency of LCD screen.
- (2) Do cleaning with a soft cloth (100% cotton).
- (3) Use antistatic agent but don't rub it strongly.

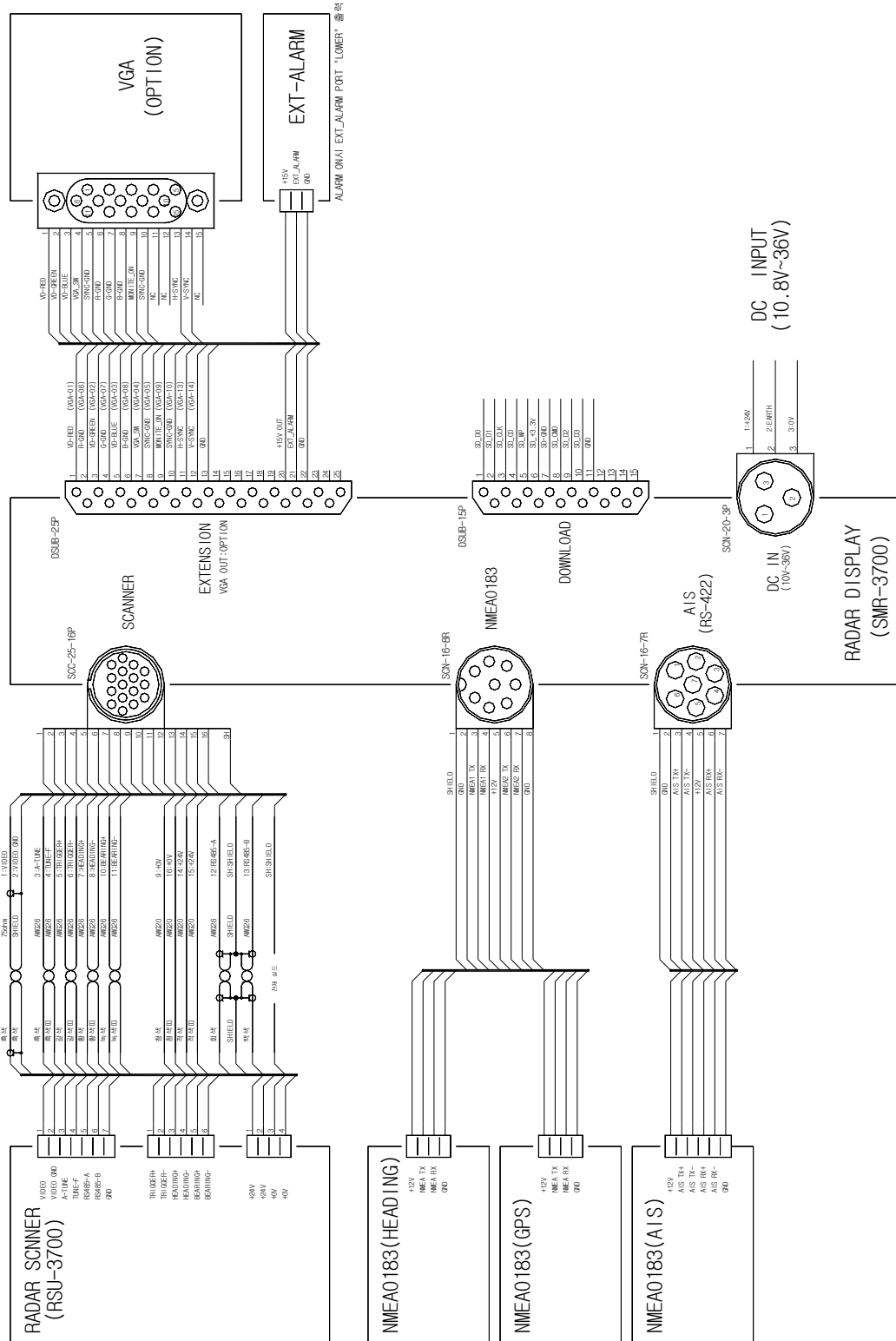



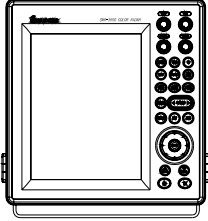
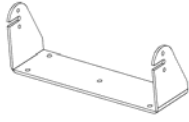

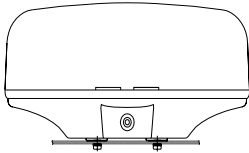
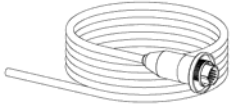
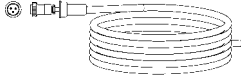
# Chapter 7. Installation drawing and circuit diagram

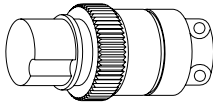
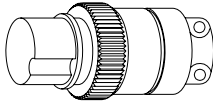

## Chapter 7. Packinglist

SMR-3700 (36Mile Marine RADAR)							
NO.	Item	External Drawing	Dimension		Qty	Chk	Remark
1	Display		SMR-3700		1		
			CODE NO.	SMR-3700			
2	Bracket				1		
			CODE NO.	ACC-RADAR-001			
3	Knob		Ø6 × 20		2		
			CODE NO.	ACC-6X18MM-002			
4	Scanner		RSU-3700		1		
			CODE NO.	RSU-3700			
5	Scanner Cable		SAMYUNG Ø11 X 16C		1		Cap SRCN2A 25-16P L=15m
			CODE NO	RSU-3700-15M			
6	Power Cable		CVV-SB2.0 SQ X 2C		1		Cap SCN20- 3P L=3m
			CODE NO.	ACC-CAB-010			
7	Ground Cable		KIV 5.5mm <sup>2</sup>		1		L=3m
			CODE NO.	STR -595			

8	Stainless Piece		Ø4 X 16		5		
			CODE NO.	SPR-1407			
9	Connector, 7pin		SCN-16-7P		1		
			CODE NO.				
10	Coconnector, 8pin		SCN-16-8P		1		
			CODE NO.				
<b>RSU-3700</b> (Scanner Installation Material)			CODE NO.	ACC-PAK-001			
11	Hexagon Bolt		Ø10 X 25		4		
			CODE NO.	ACC-SC-001			
12	Spring Washer		Ø10		4		
			CODE NO.	ACC-WA-001			
13	Flat Washer		Ø10		4		
			CODE NO.	ACC-WA-002			
14	Fuse		7A		2		
			CODE NO.	ADD-FUSE-001			
15	Manual				1		
			CODE NO.	SMR-3700-MK			
16	Scanner Dwg. Install'n				1		
			CODE NO.	RSU-3700-DK			

**\*Note:** This user manual shall remain our property. They may not without our written consent, either in their original state or with any changes, be copied or reproduced, disclosed to or delivered to anyone unauthorized nor used for other purposes than what has been confirmed by SAMYUNG ENC in writing. SAMYUNG ENC CO.,LTD.

Note: This equipment has been tested and found to comply with the limits for a Class A digital device, pursuant to part 15 of the FCC Rules. These limits are designed to provide reasonable protection against harmful interference when the equipment is operated in a commercial environment. This equipment generates, uses, and can radiate radio frequency energy and, if not installed and used in accordance with the instruction manual, may cause harmful interference to radio communications. Operation of this equipment in a residential area is likely to cause harmful interference in which case the user will be required to correct the interference at his own expense.