

SCR

AMUT04 eSense - EAR TAG SPECIFICATIONS

[CONFIDENTIAL]

Zeev K.

Ver 2



Version History:

1	Initial version
2	Product name update

Contents

- 1. Global system specifications 4
 - 1.1 System components 4
 - 1.2 TAG - BU communication overview..... 4
- 2 eSense Ear TAG Specifications..... 5
 - 2.1 General description 5
 - 2.2 2.4GhZ Transceiver Parameters 5
 - 2.3 NFC Parameters..... 5
 - 2.4 Mechanical dimensions..... 6
 - 2.5 Block diagram 7
- 3 Environmental Conditions 7
- 4 eSense Ear TAG Installation instructions..... 8

eSense EAR TAG

FCC ID: AMUT04

Manufacturer: SCR Engineers Ltd.

This device complies with Part 15 of the FCC Rules.

Operation is subject to the following two conditions:

- (1) This device may not cause harmful interference, and
- (2) this device must accept any interference received, including interference that may cause undesired operation.

The FCC Wants You to know

NOTE: This equipment has been tested and found to comply with the limits for a Class B digital device, pursuant to part 15 of the FCC Rules. These limits are designed to provide reasonable protection against harmful interference in a residential installation. This equipment generates, uses and can radiate radio frequency energy and, if not installed and used in accordance with the instructions, may cause harmful interference to radio communications. However, there is no guarantee that interference will not occur in a particular installation. If this equipment does cause harmful interference to radio or television reception, which can be determined by turning the equipment off and on, the user is encouraged to try to correct the interference by one or more of the following measures:

- Reorient or relocate the receiving antenna.
- Increase the separation between the equipment and receiver.
- Connect the equipment into an outlet on a circuit different from that to which the receiver is connected.
- Consult the dealer or an experienced radio/TV technician for help.

FCC Warning

Changes or modifications to this equipment not expressly approved by the party responsible for compliance (SCR Engineers Ltd.) could void the user's authority to operate the equipment

1. Global system specifications

All units are for outdoor use, required Radio regulations according to target market & Low voltage 24VDC regulation (except for tags which powered by internal battery).

1.1 System components

eSense Ear TAG – Activity based tag with 2.4GhZ transceiver.

BU-500 – LD Base unit, with RS-485 network interface and 2.4GhZ transceiver.

BU-500E – LD Base unit, with 10BASE-T/100BASE-TX Ethernet network interface and 2.4GhZ transceiver.

1.2 TAG - BU communication overview

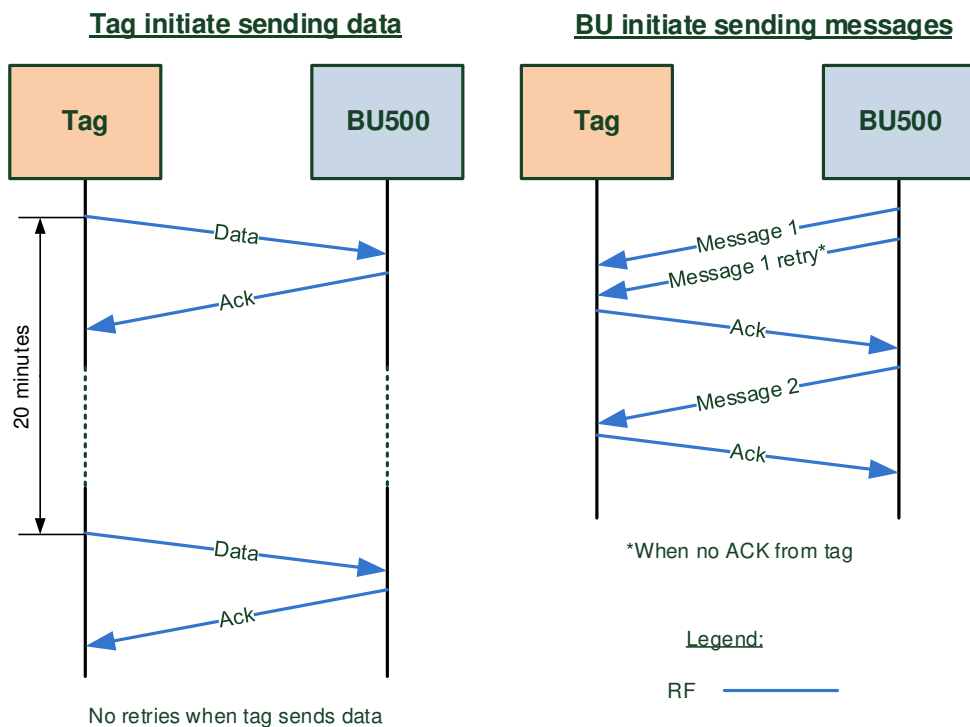

2 eSense Ear TAG Specifications

2.1 General description

eSense Ear TAG is a unit mounted on animal ear, used for the following:

1. Identification of animal using 2.4GHz transceiver and/or NFC reader unit.
2. Measure various animal parameters, processes and transmit them via 2.4 GHz to the base unit (BU500/E).

The tag transmits a 4ms message every few minutes.

Outdoor installation, sealed unit, powered from internal 3.6V battery.



2.2 2.4GHz Transceiver Parameters

RF Transceiver: Atmel AT86RF233

RF Frequency: 2.405-2.48GHz

Modulation type: QPSK

RF Channels: 5MHz separation 16ch

Baud Rate: 250K Bit/Sec (Not configurable)

Output power: 3.5dBm max

Antenna type: PCB Omni-directional

Antenna gain: Average 0dBi (Max gain: 1.5dBi)

Average RF data: 3 messages/hour, 1mSec/message, ~30bytes/message.

2.3 NFC Parameters

Utilizing **Passive** internal NFC High Frequency inlay (IC and Antenna) complying with the following standards

- ISO/IEC 15693-2, -3
- ISO/IEC 18000-3 Compliant
- 13.56-MHz Operating Frequency

2.4 Mechanical dimensions

All dimensions in mm

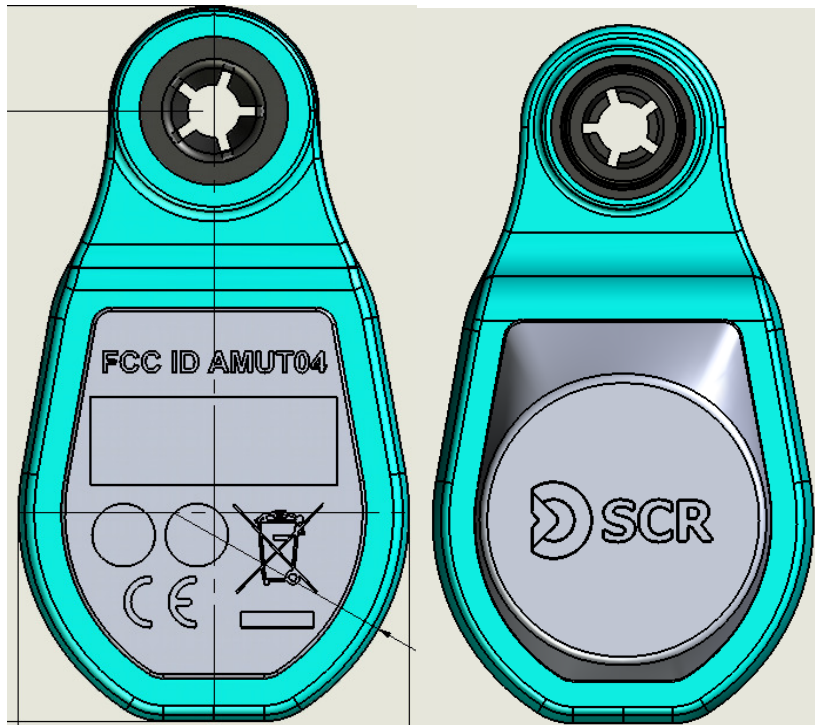
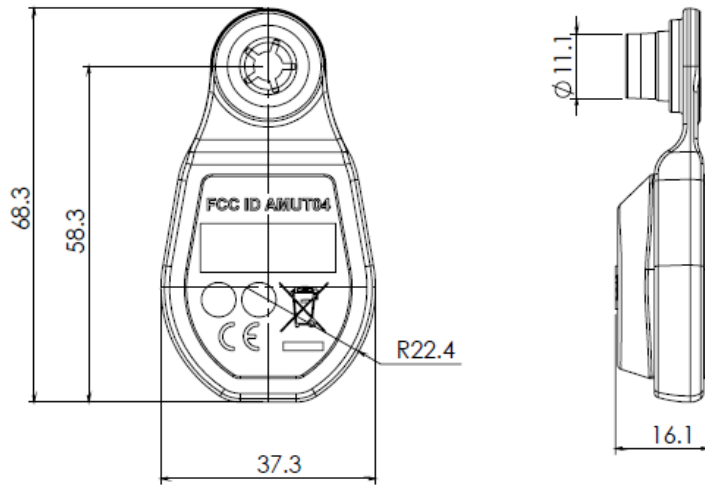

3 Environmental Conditions

1. **IP** – required IP67.
2. **Operational temperature** -33°C to 50°C.
3. **Storage** – TBD
4. **Transportation**
Complies with ETS 300 019 -2-2 T2.3
Complies with ETS 300 019 -2-1 T 1.2

4 eSense Ear TAG Installation instructions

It is important to correctly attach the tags to the cow's ear in a secure manner in order to avoid them from turning or falling off.

To securely attach the tag to the cow's ear:

1. Ensure that your tag assembly kit includes the following parts:
 - i. eSense Ear TAG
 - ii. Pins – optional MO5 1195 or similar as will be decided in future



-
-
- iii. Applicator - Universal tagger



A properly mounted tag should look like this picture:

