

Limited 1 Year Warranty

iHome Products, a division of SDI Technologies Inc., (hereafter referred to as SDI), warrants this product to be free from defects in workmanship and materials, under normal use and conditions, for a period of one (1) year from the date of original purchase.

iHome Products, a division of SDI Technologies Inc., (hereafter referred to as SDI), warrants this product to be free from defects in workmanship and materials, under normal use and conditions, for a period of one (1) year from the date of original purchase. Should this product fail to function in a satisfactory manner, it is best to first return it to the store where it was originally purchased. Should this fail to resolve the matter and service still be required by reason of any defect or malfunction during the warranty period, SDI will repair or, at its discretion, replace this product without charge. This decision is subject to verification of the defect or malfunction upon delivery of this product to the Factory Service Center authorized by Customer Service.

If service is required, please call Customer Service at 1-800-288-2792 to obtain a Return Authorization Number and shipping instructions.

Disclaimer of Warranty

NOTE: This warranty is valid only if the product is used for the purpose for which it was designed. It does not cover (i) products which have been damaged by negligence or willful actions, misuse or accident, or which have been modified or repaired by unauthorized persons; (ii) cracked or broken cabinets, or units damaged by excessive heat; (iii) damage to digital media players, CDs or tape cassettes (if applicable); (iv) the cost of shipping this product to the Factory Service Center and its return to the owner.

This warranty is valid only in the United States of America and does not extend to owners of the product other than to the original purchaser. In no event will SDI or any of its affiliates, contractors, resellers, their officers, directors, shareholders, members or agents be liable to you or any third party for any consequential or incidental damages, any lost profits, actual, exemplary or punitive damages. (Some states do not allow limitations on implied warranties or exclusion of consequential damages, so these restrictions may not apply to you.) This warranty gives you specific legal rights, and you may also have other rights which vary from state to state.

Your acknowledgement and agreement to fully and completely abide by the above mentioned disclaimer of warranty is contractually binding to you upon your transfer of currency (money order, cashier's check, or credit card) for purchase of your SDI product.

© 2015 SDI Technologies, Inc., All rights reserved
Questions? Visit www.ihome.com
or call 1-800-288-2792 Toll Free

Printed in China

iBT15-150114A(EN)



Model: iBT15

**Splashproof
Wireless Speaker
with Speakerphone**



**CHARGE
BEFORE
USE**

instruction manual



What's Included

- iBT15 speaker
- micro USB charging cable
- carry strap

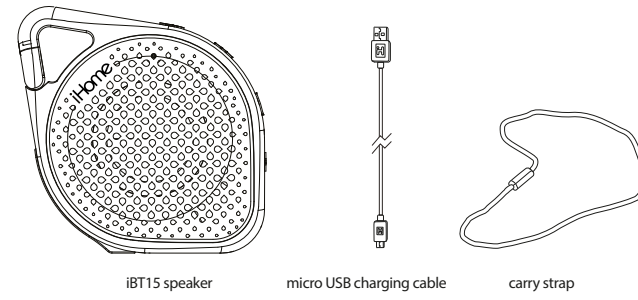

iBT15 speaker micro USB charging cable carry strap

1

Pairing Your Device

Pairing is the setup process to introduce your Bluetooth-capable device to the iBT15. Once your device is paired, the iBT15 can recognize it and you can play your audio through it.

1. Make sure your Bluetooth device is fully charged. Turn on your Bluetooth device and make it "discoverable" by turning on Bluetooth mode (check in Options or Settings).
2. Press the **Power/End Call Button** to turn on the iBT15. The first time the unit is powered on, it will enter auto-pairing mode and attempt to connect to a Bluetooth device. Otherwise, follow step 3 to begin pairing.
3. Press and hold the **Talk/Bluetooth/Play/Pause Button** on the right of the unit for 2 seconds. The unit will beep twice and the status indicator LED will flash blue, indicating the unit is in pairing mode.
4. "iHome iBT15" should appear in your device's Bluetooth menu. If "Not Paired", "Not Connected" or similar message appears, select "iHome iBT15" to connect it. If prompted for a passcode, enter "1234" on your device's keypad.

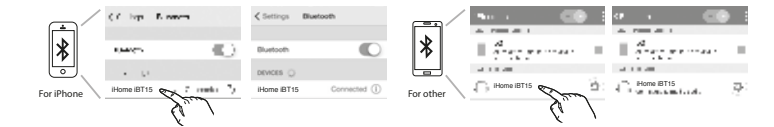

5. Once pairing is successful, a tone will sound and the Bluetooth indicator light will glow solid, indicating the iBT15 is ready to play music. There should also be an indication on your device. If no device is successfully paired within 3 minutes the iBT15 will default to previous mode. Once the iBT15 is paired to a device, it will attempt to autolink when the device is within range (about 30 feet).

5

Consumer Product Safety Guide IMPORTANT SAFETY INSTRUCTIONS

When used in the directed manner, this unit has been designed and manufactured to ensure your personal safety. However, improper use can result in potential electrical shock or fire hazards. Please read all safety and operating instructions carefully before installation and use, and keep these instructions handy for future reference. Take special note of all warnings listed in these instructions and on the unit.

1. **Water and Moisture** – DO NOT immerse unit in water. Make sure the seal and surrounding surfaces are completely dry before opening seal to prevent moisture from damaging the internal electronics. Keep seal free of dirt, sand, or other objects that can interfere with proper sealing. If for any reason the seal is not making a tight seal, water may enter the unit.
2. **Ventilation** – The unit should be situated so that its location or position does not interfere with its proper ventilation. For example, it should not be situated on a bed, sofa, rug or similar surface that may block ventilation openings.
3. **Heat** – The unit should be situated away from heat sources such as radiators, heat registers, stoves or other appliances (including amplifiers) that produce heat.
4. **Power Sources** – The unit should be connected to a power supply only of the type described in the operating instructions or as marked on the appliance.
5. **Cleaning** – The unit should be cleaned only using a warm damp cloth. Do not use solvents, etc.
6. **Objects and Liquid Entry** – Care should be taken so that objects do not fall and liquids are not spilled into any openings or vents located on the product.

7. **Attachments** – Do not use attachments not recommended by the product manufacturer.
8. **Lightning and Power Surge Protection** – Unplug the unit from the wall socket and disconnect the antenna or cable system during a lightning storm or when it is left unattended and unused for long periods of time. This will prevent damage to the product due to lightning and power-line surges.
9. **Overloading** – Do not overload wall sockets, extension cards, or integral convenience receptacles as this can result in a risk of fire or electric shock.
10. **Damage Requiring Service** – The unit should be serviced by qualified service personnel when:
 - A. the power supply cable or plug has been damaged.
 - B. objects have fallen into or liquid has been spilled into the enclosure.
 - C. the unit has been exposed to rain.
 - D. the unit has been dropped or the enclosure damaged.
 - E. the unit exhibits a marked change in performance or does not operate normally.
11. **Periods of Nonuse** – If the unit is to be left unused for an extended period of time, such as a month or longer, fully charge the unit before storing.
12. **Servicing** – The user should not attempt to service the unit beyond those methods described in the user's operating instructions. Service methods not covered in the operating instructions should be referred to qualified service personnel.

Questions? Visit www.ihome.com
or call 1-800-288-2792 Toll Free

FCC Information

iBT15

FCC ID: EMOiBT15
IC: 986B-iBT15

FCC Radiation Exposure Statement

This equipment complies with FCC RF radiation exposure limits set forth for an uncontrolled environment.

This device complies with Part 15 of the FCC Rules, operation is subject to the following two conditions: (1) This device may not cause harmful interference, and (2) this device must accept any interference received, including interference that may cause undesired operation.

- Warning: Changes or modifications to this unit not expressly approved by the party responsible for compliance could void the user's authority to operate the equipment.
- NOTE: This equipment has been tested and found to comply with the limits for a Class B digital device, pursuant to Part 15 of the FCC Rules.

These limits are designed to provide reasonable protection against harmful interference in a residential installation. This equipment generates, uses and can radiate radio frequency energy and, if not installed and used in accordance with the instructions, may cause harmful interference to radio communications.

However, there is no guarantee that interference will not occur in a particular installation. If this equipment does cause harmful interference to radio or television reception, which can be determined by turning the equipment off and on, the user is encouraged to try to correct the interference by one or more of the following measures:

- Reorient or relocate the receiving antenna.
- Increase the separation between the equipment and receiver.
- Connect the equipment into an outlet on a circuit different from that to which the receiver is connected.
- Consult the dealer or an experienced radio/TV technician for help.

CAN ICES-3 (B)/NMB-3(B)

IC Statement

This device complies with Industry Canada licence-exempt RSS standard(s). Operation is subject to the following two conditions: (1) this device may not cause interference, and (2) this device must accept any interference, including interference that may cause undesired operation of the device.

Le présent appareil est conforme aux CNR d'Industrie Canada applicables aux appareils radio exempts de licence. L'exploitation est autorisée aux deux conditions suivantes : (1) l'appareil ne doit pas produire de brouillage, et (2) l'utilisateur de l'appareil doit accepter tout brouillage radioélectrique subi, même si le brouillage est susceptible d'en compromettre le fonctionnement.

The device meets the exemption from the routine evaluation limits in section 2.5 of RSS 102 and compliance with RSS-102 RF exposure, users can obtain Canadian information on RF exposure and compliance.

Le dispositif rencontre l'exemption des limites courantes d'évaluation dans la section 2.5 de RSS 102 et la conformité à l'exposition de RSS-102 rf, utilisateurs peut obtenir l'information canadienne sur l'exposition et la conformité de rf.

Declaration ID D024962

Introduction

Thank you for purchasing the iHome iBT15. This product is designed to provide high quality wireless sound for your iPad, iPhone, iPod, computer, PDA or other Bluetooth audio device. This instruction booklet explains the basic operation and care of the unit. Please read them carefully and keep for future reference.

IMPORTANT INFORMATION ABOUT SPLASH PROOF USE

For proper splash-proof operation, make sure the seal on the left side of the unit is completely flush with the unit by pressing along the entire edge of the seal until it is completely and securely in place.

- The unit is IPX5 rated, meaning it will repel a stream of water for up to 5 minutes.
- DO NOT immerse the unit in water.
- Make sure seal and surrounding surfaces are completely dry before opening seal to prevent moisture from damaging the internal electronics.
- Keep seal free of dirt, sand, or other objects that can interfere with proper sealing. If for any reason the seal is not making a tight seal, water may enter the unit.
- DO NOT clean unit with oily soaps or use chemicals or solvents. Clean with damp cloth.

Maintenance

- Place the unit on a level surface away from sources of direct sunlight or excessive heat.
- Protect your furniture when placing your unit on a natural wood and lacquered finish. A cloth or other protective material should be placed between it and the furniture.
- Clean your unit with a soft cloth moistened only with mild soap and water. Stronger cleaning agents, such as benzene, thinner or similar materials can damage the surface of the unit.

Jan 16, 2015r

Jan 14, 2015r

Meet Your iBT15

iBT15

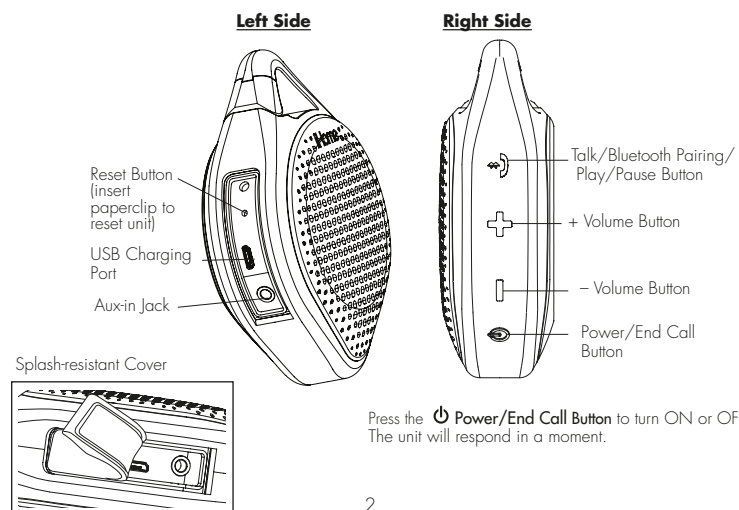

2

Top

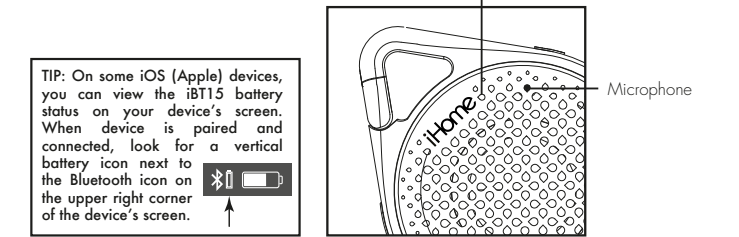

TIP: On some iOS (Apple) devices, you can view the iBT15 battery status on your device's screen. When device is paired and connected, look for a vertical battery icon next to the Bluetooth icon on the upper right corner of the device's screen.

Status indicator	Status
Solid red LED	Unit is charging
Flashing red LED	Unit needs charging
Solid blue LED	Active Bluetooth connection / Aux mode
Quickly flashing blue LED	Unit is attempting to pair with Bluetooth device
Slowly flashing blue LED	Unit is attempting to auto link to already paired Bluetooth device

3

Using the iBT15

Getting Started: Carabiner & Carry Strap

The iBT15 has a built-in carabiner clip and comes with a lanyard for easy carrying or attaching to a backpack, shower head, etc.

To attach the lanyard, form a small loop in one end of the lanyard. Insert this loop through the carabiner on top of the unit, then pull the loop back through the larger loop formed in the lanyard to tighten.

Getting Started: Charging the Unit

Charge unit before use. For first time charge, charge for at least 4 hours. Pull back splash-proof seal and connect the included micro USB cable to the USB Charging Port on the left side of the unit and connect the other standard USB plug to a computer, USB AC adaptor (not included) or other USB power source. The status indicator glows solid red while charging and turns off once charged.

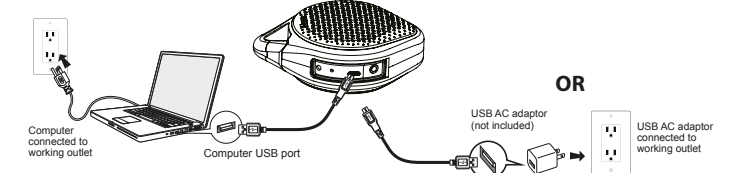

4

Playing Audio via Aux In

1. Connect one end of a 3.5mm audio cable (not included) to the Aux-in jack on the left side of the unit and connect the other end to the headphone or line-out jack on your audio device.
2. Press the **Power/End Call Button** on the unit to turn it on.
3. Power on the audio device and use the controls on the device to play or pause audio, and navigate tracks.
4. Press the **-** or **+** Button to adjust the system volume. You can also adjust volume on your device.
5. When done listening, press the **Power/End Call Button** to turn the unit OFF. Remember to turn off your device, too.

NOTE: Make sure no Bluetooth device is playing when you want to listen to Aux-in or you will hear Bluetooth instead of Aux-in. Pause the Bluetooth source and Aux-in audio will be heard in a moment.

Using the iBT15

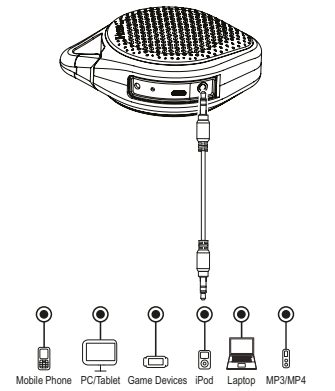

7

Internal Rechargeable Lithium-ion Battery

This device uses an internal rechargeable lithium-ion battery that should last the lifetime of the device. If you suspect your battery may be dead, try charging it several times. If the battery does not recharge, please contact us for repair information.

WARNING/DISPOSAL OF UNIT

Please do NOT attempt to change the battery yourself. If the battery has died and you do not want us to replace your battery, you should follow the disposal instructions below:

- Never dispose of used batteries/electronics with ordinary solid wastes, since they contain toxic substances.
- Always dispose of used batteries/electronics in accordance with the prevailing community regulations that apply to the disposal of batteries/electronics. If there are no local regulations concerning battery/electronics disposal, please dispose of the device in a waste bin for electronic devices.
- Many electronics retailers now recycle batteries and other electronic components at no charge. Check to see which ones in your area do so.
- A warning that batteries (battery pack or batteries installed) shall not be exposed to excessive heat such as sunshine, fire or the like.

CAUTION

The battery used in this device may present a risk of fire, explosion or chemical burn if mistreated

- Never use or charge the battery if it appears to be leaking, discolored, deformed, or in any way abnormal.
- Never disassemble the unit or attempt to remove battery as that could cause leakage of alkaline solution or other electrolytic substance.
- Always confirm that the temperature is 5°C ~ 35°C (41° ~ 95° Fahrenheit) when you charge the battery. Leakage or deterioration of the battery may occur if this warning is not heeded.
- Never expose the battery to any liquid.
- Never expose the battery to excessive heat such as direct sunlight or fire. Never use the battery pack in an unventilated vehicle where excessive internal temperatures may be encountered.
- Always keep the battery out of the reach of infants and small children.

Jan 13, 2015

Jan 13, 2015
numbers changed

Jan 13, 2015

Jan 14, 2015