

Model: iBT22 (For 8605 IC)
IB (English) - Adaptor Change to 5V
Size: 153mm x 120mm
Printing color: Black
Date : Dec 24, 2013

P1

iHome®



iBT22 (USA)
iBT22B (Canada)
**Bluetooth Wireless
Dual Alarm Clock**



instruction manual

Introduction

Thank you for purchasing the iHome iBT22. This product is designed to provide high quality wireless sound for your iPad, iPhone, iPod, computer, PDA or other Bluetooth audio device.

Along with the included Quick Bluetooth Connection Guide this instruction booklet explains the basic operation and care of the unit. Please read them carefully and keep for future reference.

Maintenance

- Place the unit on a level surface away from sources of direct sunlight or excessive heat.
- Protect your furniture when placing your unit on a natural wood and lacquered finish. A cloth or other protective material should be placed between it and the furniture.
- Clean your unit with a soft cloth moistened only with mild soap and water. Stronger cleaning agents, such as benzene, thinner or similar materials can damage the surface of the unit.

FCC Information

FCC ID: EMOIBT21
IC: 986B-IBT21

FCC Radiation Exposure Statement

This equipment complies with FCC RF radiation exposure limits set forth for an uncontrolled environment. This transmitter must not be co-located or operating in conjunction with any other antenna or transmitter.

This Device complies with RSS-210 of the IC Rules; Operation is subject to the following two conditions:

- (1) This device may not cause interference and
- (2) This device must accept any interference received, including interference that may cause undesired operation

This device complies with Part 15 of the FCC Rules, operation is subject to the following two conditions: (1) This device may not cause harmful interference, and (2) this device must accept any interference received, including interference that may cause undesired operation.

- Warning: Changes or modifications to this unit not expressly approved by the party responsible for compliance could void the user's authority to operate the equipment.
- NOTE: This equipment has been tested and found to comply with the limits for a Class B digital device, pursuant to Part 15 of the FCC Rules. These limits are designed to provide reasonable protection against harmful interference in a residential installation. This equipment generates, uses and can radiate radio frequency energy and, if not installed and used in accordance with the instructions, may cause harmful interference to radio communications. However, there is no guarantee that interference will not occur in a particular installation. If this equipment does cause harmful interference to radio or television reception, which can be determined by turning the equipment off and on, the user is encouraged to try to correct the interference by one or more of the following measures:
 - Reorient or relocate the receiving antenna.
 - Increase the separation between the equipment and receiver.
 - Connect the equipment into an outlet on a circuit different from that to which the receiver is connected.
 - Consult the dealer or an experienced radio/TV technician for help.

CAN ICES-3 (B)/NMB-3(B)

IC Statement

This device complies with Industry Canada licence-exempt RSS standard(s). Operation is subject to the following two conditions: (1) this device may not cause interference, and (2) this device must accept any interference, including interference that may cause undesired operation of the device.

The device meets the exemption from the routine evaluation limits in section 2.5 of RSS 102 and compliance with RSS-102 RF exposure, users can obtain Canadian information on RF exposure and compliance.

Le dispositif rencontre l'exemption des limites courantes d'évaluation dans la section 2.5 de RSS 102 et la conformité à l'exposition de RSS-102 rf, utilisateurs peut obtenir l'information canadienne sur l'exposition et la conformité de rf.

QDID:B021180

Table of Contents

Included/ Meet Your iBT22	1-2
Installing Clock Backup Batteries	3
The Display/ Setting Up the Unit/ Turning the Unit ON and OFF	4
Setting the Time/ Daylight Saving Time	5
Setting the Alarms/ Reviewing, Arming and Disarming Alarms	6
Resetting the Alarm to Come on the Next Day	6
Snooze Operation/ Sure Alarm	7
Using Bluetooth: Pairing Your Device	8
Pairing with a Different Device/ Playing Audio Via Bluetooth/Remote Power On Via Bluetooth	9
Playing Audio via Aux In	10
Sleep Operation/ Dimmer Operation/ USB Charging	11
Consumer Product Safety Guide	12-13
Troubleshooting	14
Warranty	15

Included

- iBT22 Alarm Clock
- 100V-240V universal AC adaptor*
- Backrest
- 3 AAA batteries
- 12" patch cord

***Note:** There are two versions of this product. One uses a 7.5V 2A adaptor, and the other a 5V 2A one. **Only use the correct adaptor.** If ordering a replacement, identify the correct adaptor by checking the DC jack rating on the back of unit.



power adaptor



audio cable

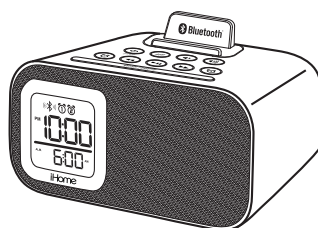

alarm clock



backrest

Installing the Backrest

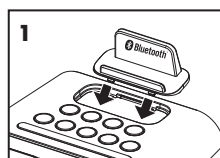

1) Insert the front tabs of the included backrest at a slight angle into the slots on top of the unit (behind the buttons).

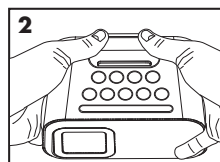

2) Grip the unit in both hands from front to back as shown and squeeze the unit slightly towards you while pressing down firmly on the backrest until it clicks into place.

Once inserted, the backrest is a permanent part of the unit and offers enhanced stability for your devices. Test your device in the backrest to make sure it is stable. A tablet may not be suitable for use with the backrest.

Meet Your iBT22

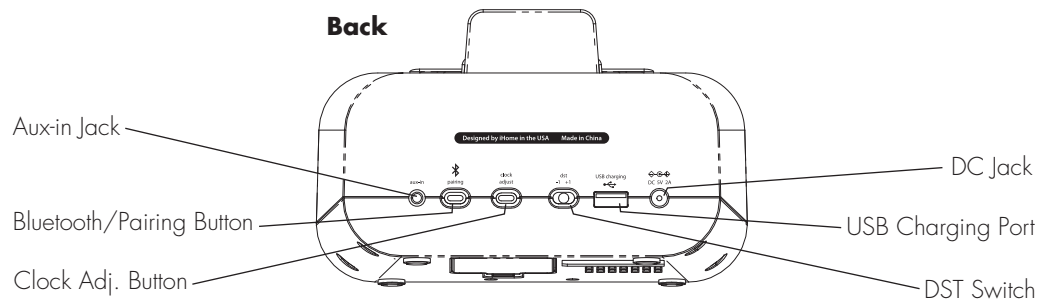
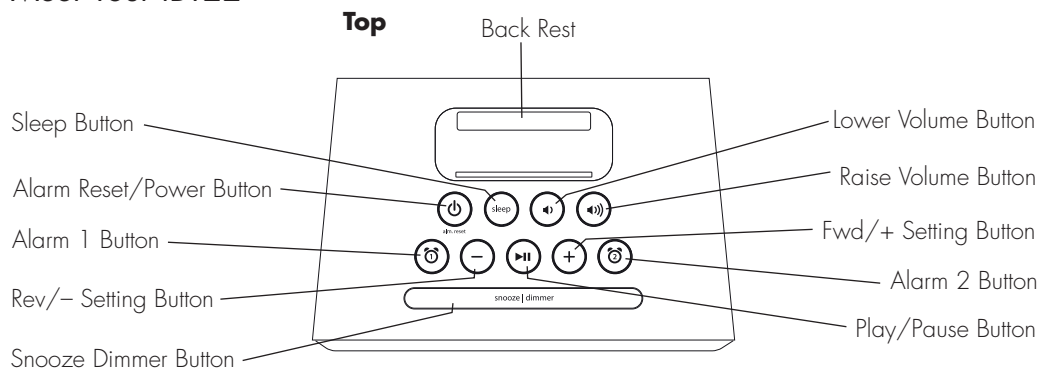

Replacing & Installing Clock Backup Batteries

The iBT22 uses 3 AAA batteries (included) for backup to provide continuous alarm operation and clock settings in the event of a power failure. If the backup batteries have been installed and a power failure occurs or the AC adaptor is accidentally disconnected, the display backlight will not remain lit, but current time and alarm time settings will be temporarily maintained. Otherwise, you must reset the time and alarm settings.

Note: You should replace backup batteries when the Battery Low Indicator appears on the display.

1. Please make sure the AC adaptor is connected. Otherwise all settings may be lost during battery replacement.
2. Open backup battery compartment door located on the bottom of the unit.
3. Insert three "AAA" batteries, checking the + and - ends of the batteries match the diagram inside the compartment. We recommend to use alkaline battery for longer life. Do not mix alkaline, standard (carbon-zinc) or rechargeable (nickel-cadmium) batteries.
4. Close the compartment cover.

Note: Make sure you dispose of batteries properly (see your local regulations).

Battery Low Indicator

The Battery Low Indicator is located at the top left of the display. When it blinks it is time to replace backup batteries.

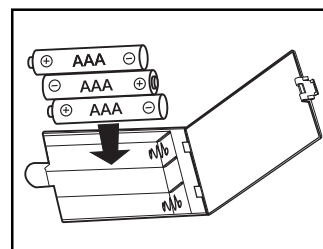

The Display

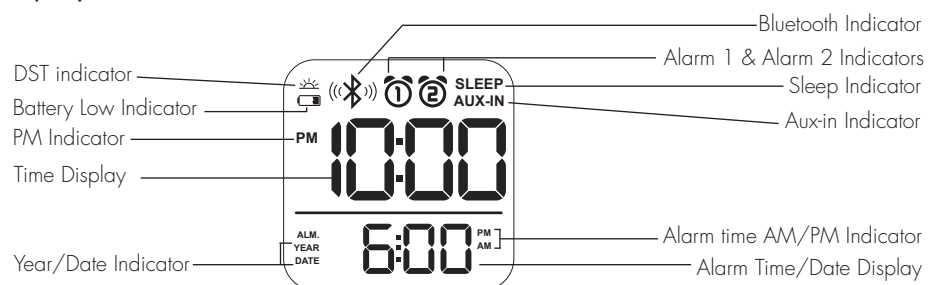

Setting Up the Unit

1. Connect the included AC adaptor to the DC jack located on the back of the unit and connect the other end to a working wall outlet.

Turning the Unit ON and OFF*

1. Once the AC adaptor is properly connected, press the **Power Button** located on top of the unit to turn the unit ON. "ON" will appear briefly on the display.
2. Press the **Power Button** to turn the unit OFF. "OFF" will appear briefly on the display.

NOTE: The unit has an automatic shut off function: if no audio is detected for 3 minutes, the unit will power off.

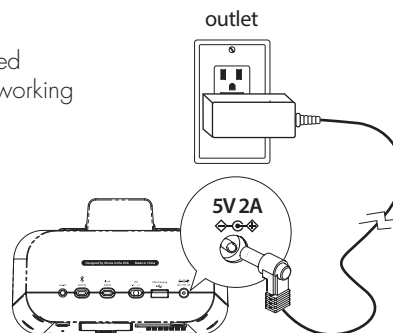

* see page 9 for details on powering the unit ON remotely using a paired Bluetooth device

Setting the Time



1. Press and hold the **Clock Adjust Button** (located on the back of the unit) until the time flashes in the display and a beep sounds.
2. Press and release the **-** or **+** **Buttons** to adjust the clock to the current time (hold to advance or reverse rapidly). Make sure to set the correct AM/PM time. The PM indicator appears to the left of the time display; there is no AM indicator.
3. Press and release the **Clock Adjust Button**. The year will flash on the display and a beep will sound.
4. Press and release the **-** or **+** **Buttons** until the current year is displayed (hold to advance or reverse rapidly).
5. Press and release the **Clock Adjust Button** again. The date will flash on the display and a beep will sound.
6. Press and release the **-** or **+** **Buttons** until the current date is displayed (hold to advance or reverse rapidly).
7. Press and release the **Clock Adjust Button** again to complete time setting. You will hear 2 beeps to confirm time setting is complete.

NOTE: Press the **⏸** or **⏹** **Button** at any time during time setting to toggle between standard 12 hour display and 24 hour ("military") display modes.

Daylight Saving Time

1. Slide the **DST (Daylight Saving Time) Switch** located on the back of the unit to +1 to add one hour for daylight saving time or slide to -1 to subtract an hour for standard time. The DST icon will appear on the display when switch is set to +1 to indicate daylight saving time.

Setting the Alarms

1. By default, the unit selects the most recently linked Bluetooth device as your wake-to source. If no Bluetooth device is detected, the iBT22 will automatically default to buzzer alarm. See page 8 to setup your Bluetooth device.
Note: make sure you have an hour of audio on your Bluetooth device.
2. Press and hold the  **Button** until the current alarm time flashes in the lower part of the display and a beep sounds.
Press the **-** or **+** **Button** to set the alarm time. Remember to set the correct AM or PM time.
3. Press the  **Button** (or if no button is pressed within 10 seconds). Two beeps will confirm alarm time and exit alarm setting mode. The alarm will be armed and the corresponding alarm icon will appear.
4. To set Alarm 2 just follow steps 2 - 3 using the  **Button**.

Reviewing, Arming and Disarming Alarms

1. Once an alarm is set, it is armed and the lower part of the display will show the alarm time. If both alarms are armed, the earliest alarm time will show.
2. To arm/disarm the alarm, just press the associated alarm button to toggle it on or off. If the alarm is armed, the related alarm icon will appear in the upper part of the display.

Resetting the Alarm to Come On the Next Day

When the alarm is sounding, press the  **Button** to stop alarm and reset it to come on the following day.

Snooze Operation

1. Press and hold the **Snooze/Dimmer Button** for a few seconds to enter set snooze timer mode. A beep will sound and the display will flash. Press the **-** or **+ Button** to set the snooze timer from 1 to 29 minutes. Press the **Snooze/Dimmer Button** to exit. Two confirmation beeps will sound.
2. Press the **Snooze/Dimmer Button** after the alarm sounds. The alarm will be silenced and come on again after the set snooze time. Snooze can be pressed several times during the 1 hour alarm cycle.

Sure Alarm

The iBT22 has a sure alarm feature. If backup batteries are installed, the buzzer alarm will still sound in the event of power failure.

Using Bluetooth: Pairing Your Device

NOTE: See the iBT22 Bluetooth Connection Guide for complete pairing details.

Whenever it is powered on, this unit will attempt to autolink to a previously paired device. If no device is detected, the unit will automatically enter pairing mode for 2 minutes. You can manually initiate pairing without turning on the unit by following steps 1-3 below.

1. Make sure your Bluetooth device is fully charged. Turn on your Bluetooth device and make it "discoverable" by turning on Bluetooth mode (check in Options or Settings) .
2. **Press and hold** the **Bluetooth Pairing Button** on the back of the unit for 2 seconds. The unit will beep and the Bluetooth icon will flash on the display, indicating the unit is in pairing mode.
3. "iHome iBT22" should appear in your device's menu. If "Not Paired", "Not Connected" or similar message appears, select "iHome iBT22" to connect it. If prompted for a passcode, enter "**1234**" on your device's keypad.
4. If pairing is successful, 2 beeps will sound, "**PAIR**" will appear briefly in the bottom display and the Bluetooth icon will become solid. There should also be an indication on your device. If no device is successfully paired within 2 minutes the unit will default to previous mode. Once unit is paired to a device, it will attempt to autolink when the device is within range (about 30 feet).

Pairing with a Different Device

1. When you power ON the speaker, it will automatically link with the previously paired Bluetooth device as long as that device is still within range (approx. 30 feet). To pair with a different device follow steps 1 - 4 under "Pairing Your Device" on previous page.

Playing Audio Via Bluetooth

1. Press the **⏻ Button** to turn on the unit. The Bluetooth icon will be displayed when a linked device is in range and detected. You can then listen to audio streamed wirelessly from your paired iPad, iPhone, iPod or other Bluetooth device.
2. Press the **▶|| Button** to play audio from your device. Press again to pause play and once more to resume play. When Bluetooth audio is active, the audio icon will be displayed around the Bluetooth icon (Ⓜ).
3. Press the **-** or **+** **Button** to navigate tracks on your device.
4. Press the **🔊** or **🔊) Button** to adjust the system volume. You can also adjust volume on your device.
5. When done listening, press the **⏻ Button** to turn the unit OFF. Remember to turn off your device, too.

Remote Power On Via Bluetooth

When within range (about 30 feet) of the unit, your previously paired device will autolink to the unit. Pressing play on your device will **remotely power on the unit** and in a few moments your audio will play through the unit at the current set volume. On some devices, alert sounds from the device will also be transmitted.

Playing Audio via Aux In

1. Connect one end of the included 3.5mm stereo audio cable to the Aux-in jack on the back of the unit and connect the other end to the headphone or line-out jack on your audio device.
2. Press the **⏻ Button** on the unit to turn it on.
3. Power on the audio device and use the controls on the device to play or pause audio, and navigate tracks.
4. Press the **🔊 or 🔊) Button** to adjust the system volume. You can also adjust volume on your device.
5. When done listening, press the **⏻ Button** to turn the unit OFF. Remember to turn off your device, too.

NOTE: Make sure no Bluetooth device is playing or you will hear both the Aux -in and Bluetooth playing.

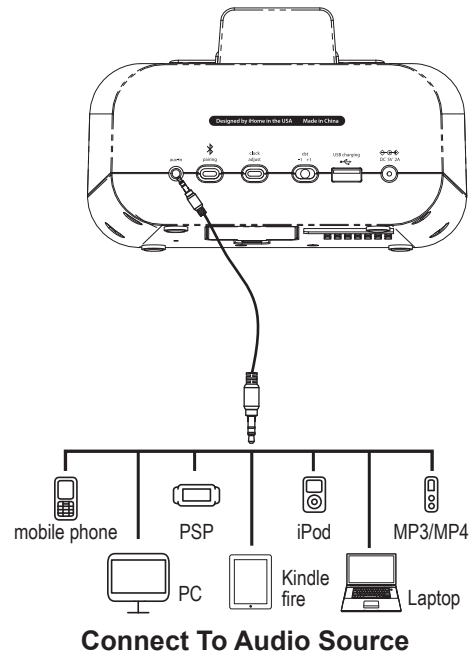

Sleep Operation

Sleep mode lets you sleep to your Bluetooth device until the unit shuts off at a selected time. It will send a power off command to your device, too.

1. Press the **Sleep Button** to enter sleep mode. The Sleep Icon will appear on the display to indicate it is in sleep mode.
2. Press the **Sleep Button** as needed to adjust the sleep timer from 120, 90, 60, 30 or 15 minutes (or turn sleep mode OFF by pressing the **⏻ Button**).
3. When the display changes back to show the real time, press the **Sleep Button** once to show the sleep time remaining. Pressing it again to change sleep time to the next lowest increment.
4. To stop listening at any time, press the **⏻ Button** to turn the unit OFF. Remember to turn off your device, too.

NOTE: The next time you turn the unit on and press **Sleep Button** it will default to the last set sleep time.

Dimmer Operation

During normal operation, press the **Snooze/Dimmer Button** to control the brightness of the LCD display.

USB Charging

You can charge devices via the USB port located on the back of the unit while the unit is connected to AC power. Clock backup batteries do not power the USB charging port. Connect a USB cable (not included) to the USB port and connect the other end to your device. Monitor the charging status on your device. If it doesn't charge, you must charge it using the charger that came with it.

Consumer Product Safety Guide

IMPORTANT SAFETY INSTRUCTIONS

When used in the directed manner, this unit has been designed and manufactured to ensure your personal safety. However, improper use can result in potential electrical shock or fire hazards. Please read all safety and operating instructions carefully before installation and use, and keep these instructions handy for future reference. Take special note of all warnings listed in these instructions and on the unit.

1. **Water and Moisture** – The unit should not be used near water. For example: near a bathtub, washbowl, kitchen sink, laundry tub, swimming pool or in a wet basement.
2. **Ventilation** – The unit should be situated so that its location or position does not interfere with its proper ventilation. For example, it should not be situated on a bed, sofa, rug or similar surface that may block ventilation openings. Also, it should not be placed in a built-in installation, such as a bookcase or cabinet, which may impede the flow of air through the ventilation openings.
3. **Heat** – The unit should be situated away from heat sources such as radiators, heat registers, stoves or other appliances (including amplifiers) that produce heat.
4. **Power Sources** – The unit should be connected to a power supply only of the type described in the operating instructions or as marked on the appliance.
5. **Power-Cable Protection** – Power supply cables should be routed so that they are not likely to be walked on or pinched by items placed upon or against them. It is always best to have a clear area from where the cable exits the unit to where it is plugged into an AC socket.
6. **Cleaning** – The unit should be cleaned only using a warm damp cloth. Do not use solvents, etc.
7. **Objects and Liquid Entry** – Care should be taken so that objects do not fall and liquids are not spilled into any openings or vents located on the product.

8. **Attachments** – Do not use attachments not recommended by the product manufacturer.
9. **Lightning and Power Surge Protection** – Unplug the unit from the wall socket and disconnect the antenna or cable system during a lightning storm or when it is left unattended and unused for long periods of time. This will prevent damage to the product due to lightning and power-line surges.
10. **Overloading** – Do not overload wall sockets, extension cords, or integral convenience receptacles as this can result in a risk of fire or electric shock.
11. **Damage Requiring Service** – The unit should be serviced by qualified service personnel when:
 - A. the power supply cable or plug has been damaged.
 - B. objects have fallen into or liquid has been spilled into the enclosure.
 - C. the unit has been exposed to rain.
 - D. the unit has been dropped or the enclosure damaged.
 - E. the unit exhibits a marked change in performance or does not operate normally.
12. **Periods of Nonuse** – If the unit is to be left unused for an extended period of time, such as a month or longer, the power cable should be unplugged from the unit to prevent damage or corrosion.
13. **Servicing** – The user should not attempt to service the unit beyond those methods described in the user's operating instructions. Service methods not covered in the operating instructions should be referred to qualified service personnel.

Questions? Visit www.ihome.com
or call 1-800-288-2792 Toll Free

Troubleshooting

Unit doesn't respond (no power)

- Check that all connections are correct and properly plugged in.
- Make sure your device is properly paired with the iBT22.
- Make sure the **Power** is ON, indicated by "ON" appearing briefly on the display.
- When turning unit on via Bluetooth (initiate play mode on paired device) unit can take up to 10 seconds to power on.

Resetting the Unit

If Bluetooth function is not operating properly, you may wish to reset Bluetooth. To do so, press and hold the **Button** for 10 seconds. You will hear 2 beeps and the Bluetooth icon will be gone from the display. You will then need to re-pair any previously paired devices.

Trouble pairing device/computer with iBT22

Bluetooth implementation varies depending on your device's hardware and operating system. Please see our website for updates on pairing.

- Make sure you have the latest firmware for your device.
- Make sure your device is working properly. Check your device's manual for details on Bluetooth pairing and linking.
- When you power ON the speaker, it will automatically link with the last previously paired Bluetooth device if the device is still within range (approx. 30 feet). To pair with a different device you must turn off Bluetooth capability on the already paired device, or take it out of range.

For further information and to see the latest instructions, visit www.ihome.com/support

Limited 1 Year Warranty

iHome Products, a division of SDI Technologies Inc. (hereafter referred to as SDI), warrants this product to be free from defects in workmanship and materials, under normal use and conditions, for a period of one (1) year from the date of original purchase.

Should this product fail to function in a satisfactory manner, it is best to first return it to the store where it was originally purchased. Should this fail to resolve the matter and service still be required by reason of any defect or malfunction during the warranty period, SDI will repair or, at its discretion, replace this product without charge. This decision is subject to verification of the defect or malfunction upon delivery of this product to the Factory Service Center authorized by SDI Customer Service. The product must include proof of purchase, including date of purchase. An out-of-warranty fee for service will be charged for units that are received without proof of purchase.

Before returning this product for service, please first replace the batteries (if applicable) with fresh ones, as exhausted or defective batteries are the most common cause of problems encountered.

If service is still required:

1. Call SDI Customer Service at 1-800-288-2792 for Return Authorization and for the address of the Factory Service Center.
2. Remove the batteries (if applicable) and pack the unit in a well padded, heavy corrugated box. SDI is not responsible for damage that occurs during shipping to the Factory Service Center.
3. Enclose a photocopy of your sales receipt, credit card statement, or other proof of the date of purchase, if within the warranty period. Also include your name and address information, a brief description for why the unit is being returned, and the return authorization number. No unit can be processed without a return authorization number.
4. Write the return authorization number on the side of the shipping package and send the unit prepaid and insured to the Factory Service Center address authorized by SDI Customer Service.

Disclaimer of Warranty

NOTE: This warranty is valid only if the product is used for the purpose for which it was designed. It does not cover (i) products which have been damaged by negligence or willful actions, misuse or accident, or which have been modified or repaired by unauthorized persons; (ii) cracked or broken cabinets, or units damaged by excessive heat; (iii) damage to digital media players, CD's or tape cassettes (if applicable); (iv) the cost of shipping this product to the Factory Service Center and its return to the owner. This warranty is valid only in the United States of America and does not extend to owners of the product other than to the original purchaser. In no event will SDI or any of its affiliates, contractors, resellers, their officers, directors, shareholders, members or agents be liable to you or any third party for any consequential or incidental damages, any lost profits, actual, exemplary or punitive damages. (Some states do not allow limitations on implied warranties or exclusion of consequential damages, so these restrictions may not apply to you.) This warranty gives you specific legal rights, and you may also have other rights which vary from state to state.

Your acknowledgement and agreement to fully and completely abide by the above mentioned disclaimer of warranty is contractually binding to you upon your transfer of currency (money order, cashier's check, or credit card) for purchase of your SDI product.

© 2013 SDI Technologies, Inc. All rights reserved
Questions? Visit www.ihome.com
or call 1-800-288-2792 Toll Free