



**MA800**

## CompuStar A Controllers INSTALLATION GUIDE

**FCC ID : VA5JA800A915**

This device complies with Part 15 of the FCC Rules.

Operation is subject to the following two conditions :

- (1) This device may not cause harmful interference, and
- (2) This device must accept any interference received, including interference that may cause undesired operation.

**CAUTION** : Changes or modifications not expressly approved by the party responsible for compliance could void the user's authority to operate this device.

**IC ID : 7087A-A800A915**

**Statement** : The term "IC:" before the radio certification number only signifies that Industry Canada technical specifications were met.

**CAUTION** : The User that modifications to the unit may void the user's authority to operate the unit



[www.compuStar.com](http://www.compuStar.com)

Toll Free: 888-820-3690

21911 68<sup>th</sup> Ave S  
Kent, WA 98032

[WWW.COMPUSTAR.COM](http://WWW.COMPUSTAR.COM)

## TABLE OF CONTENTS

● Wiring Diagram .....	Page 7
● Installation of AM or Antennas and RPS .....	Page 8
● Option Programming for Four Button Remote .....	Page 9
● Option Programming for Six Button(ONE WAY) Remotes .....	Page 10
● Remote - Pager Programming Menu Options .....	Page 10

## Your Warranty

The product's warranty is automatically void if its date code or serial number is defaced, missing or altered. This warranty will not be valid unless you have completed the registration card and mailed it to Firstech, Inc., within 10 days after the purchase to the address listed on the registration card.

## Important Information

Congratulations on the purchase of your high-tech vehicle security system and remote auto-starter. This system has been designed to provide years of trouble-free operation. Due to the complexity of the system, it must only be installed by an authorized CompuStar dealer for full warranty and technical support. Installation of this product by anyone other than an authorized dealer voids the warranty.

The owner's guide should help you to get the most out of your system. Please take time to read it thoroughly prior to using this system. Additional replacement copies of this manual are available for downloading at [www.compustar.org](http://www.compustar.org).

## Safety Information

Please take these safety precautions under the following conditions:

### 1. Servicing the vehicle

When servicing (i.e. changing the oil, washing your car) your automobile, the CompuStar system should be in Valet Mode. There is a safety shutdown switch under the hood that deactivates the remote starter function if the hood is open. However, if the switch has been damaged or the switch has been installed improperly, the vehicle may start when Button II is pressed for 2 seconds even if the hood is open.

### 2. Loaning your vehicle to others

Whenever you loan your vehicle to an individual who is not familiar with CompuStar, please put the vehicle in Valet mode. This will prevent the vehicle loaner from accidentally activating the CompuStar auto-security system.

### 3. For manual transmission vehicles

If the CompuStar 2WSSR is installed in a manual transmission vehicle, extra precautions are required because the CompuStar does not monitor the gear shift :

## Important!

Under normal circumstances, Reservation Mode is cancelled when a door or hatchback opens. Please verify if the opening of any door or hatchback cancels Reservation Mode. If any of the doors or hatchback is not monitored by CompuStar because of improper installation or a faulty dome light switch, do not use the CompuStar and take your vehicle to the dealer immediately for repair.

Do not set Reservation Mode when the window(s) are open or if there is anyone inside of the vehicle including animals.

## System Maintenance

This system requires no specific maintenance. Your remote-pager is powered by a single AA battery that will last approximately one month under normal use depending on the make and model of your vehicle. There is a battery icon in the lower right corner of the CompuGLO LCD indicating remaining battery life. When the battery weakens, the operating range will be reduced and the CompuGLO LCD will dim. Contact your authorized CompuStar dealer if you have additional questions.









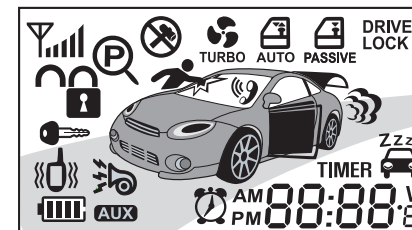



## REMOTE-PAGER : MR561/LCD

The model name, MR561, stands for **Two Way Spread Spectrum Remote with Liquid Crystal Display**. This 5-channel transmitter that allows you to activate multiple functions by pressing a combination of 4 buttons on the unit in order to transmit signals.

## CompuGLO color LCD (Liquid Crystal Display)

The remote-pager comes with CompuGLO which is a unique color LCD display that visually tells the vehicle owner the security status of your car at all times. There are differing icons that will appear on your CompuGLO LCD indicating what your vehicle is currently doing.



Icon	Explanation
Shock	Indicates if the Shock Sensor is on or off. See page 12.
Turbo	Indicate if Turbo Mode is on or off. See page 17.
Timer	Indicates if Timer Start Mode is on or off. See page 16.
Passive	Indicates if Passive Arming Mode is on or off. See page 17.
	Indicates that the second stage shock sensor has been triggered.
	If the icon appears continuously, you are in mute(vibration) mode. If the icon blinks, the first stage shock sensor has been triggered. See page 15.
	Indicates if you are in Valet Mode. See page 15.
	Indicates if your car parking lights are flashing.
	Indicates that your car siren is turned on or off when you lock or unlock the vehicle.
	Indicates that someone is paging you from your vehicle.
	Displays if your car is locked or unlocked.
	Indicates if your remote-pager is transmitting signals to the controller unit.
	Displays remaining battery life.
	Displays if your door is open.
	Displays if your vehicle has auto-started properly or ignition on.
	Displays if your trunk is open.

## Remote-Pager Button Functions

The user can activate differing functions of CompuStar 2WSSR system by pressing one or two buttons simultaneously (ex.(I+IV) ) located on the antenna side of your Compu Star remote-pager.

Channel	Button	Press for	Function	Factory Setting
1	<b>I</b>	1/2 sec	Alarm Mode - on/off, RPS - on/off	
2	<b>II</b>	1/2 sec	Auxiliary Option 1	
3	<b>III</b>	1/2 sec	Auxiliary Option 2	
4	<b>IV</b>	1/2 sec	Query Function	
5	<b>I-</b>	2 sec	Alarm Mode - on/off, RPS - on/off	
6	<b>II-</b>	2 sec	Auto-start Function - on/off	
7	<b>III-</b>	2 sec	Trunk Release - on/off	
8	<b>IV-</b>	2 sec	Panic Mode	
9	<b>( I+ II )</b>	1/2 sec	Car Siren for Lock/ Unlock-on/off	On
10	<b>( I+ III )</b>	1/2 sec	Valet Mode - on/off	Off
11	<b>( II+III )</b>	1/2 sec	Passive Arming - on/off	Off
12	<b>(II+ IV)</b>	1/2 sec	Timer Start Mode - on/off	Off
13	<b>(III+IV)</b>	1/2 sec	Turbo Mode - on/off	Off
14	<b>(I+III)-</b>	2 sec	Shock Sensor - on/off.	On
15	<b>(II+III)-</b>	2 sec	Mute mode (Vibration only) - on/off.	Off
16	<b>(I+II)-</b>	2 sec	Programming Menu 1	
17	<b>(I+III)-</b>	2 sec	Programming Menu 2	

**Note :** "( )" means simultaneously pressing the buttons  
 "( ) - " means simultaneously pressing the buttons for 2 seconds.

# Wiring Diagram

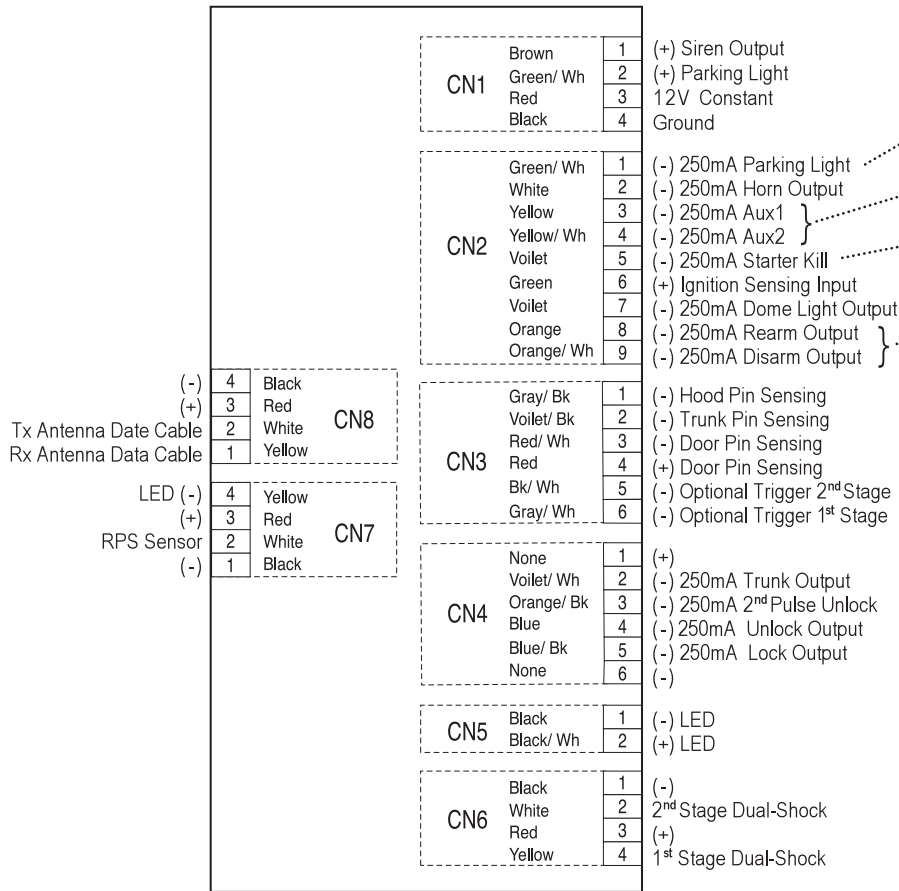

(-) Output for Parking Lights : Some vehicles, such as Jeep, have negative Parking lights.

An Aux output is a 5sec pulse that can be changed to Latch. See Programming Options.

Starter Kill supplies a negative 250mA output when the system is armed.

Dome Light Supervision : Dome light is turned on for one minute after unlock. If you program Dome Lghts Rearm option, the Voilet wire of CN2 supplies a ground pulse before Lock. The Dome Light Rearm Option is to simulate opening the door and pressing the factory lock button for factory arming.

The sequence for the Rearm pulse : pulse when armed (locked).  
The sequence for the Disarm pulse : a pulse when disarmed(unlocked).

# Installation of AM or Antennas and RPS

Installation of **AM** or Antennas and **RPS**.  
The antennas have been calibrated for horizontal installation at the left-top corner of the windshield. Different installation may adversely affect the transmitting distance.

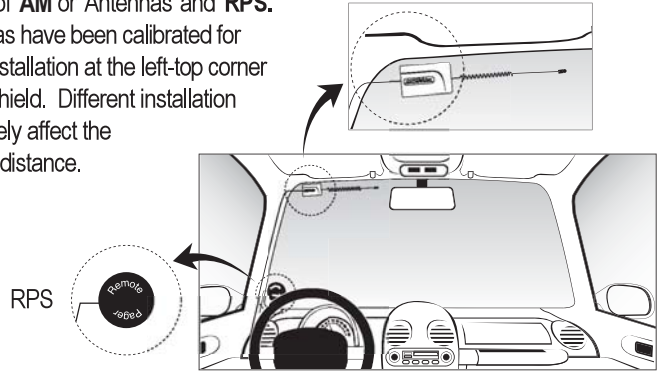

### Option Programming for Four Button Remotes

**Step1:** For programming menu 1 : Press Buttons (I+II) for 2 seconds.  
For programming menu 2 : Press Buttons (I+IV) for 2 seconds.  
The car will chirp once indicating that you are in programming mode.

**Step2:** Within a 2 seconds after pressing (I+II) or (I+IV), press Button IV the number of times to go to the option number you want to change.  
You will hear a chirp and see the parking lights flash each time when you press Button IV.

**Step3:** Wait a few seconds. You will hear a number of chirps and see a number of parking light flashes corresponding to the option number you want to change. If the number of chirps or flashes is not what you want, go back to Step 1.

**Step4:** Press Button I for the default factory settings and your car will respond by one chirp and one flash. Press Button II for the optional setting and your car will respond by two chirps and two parking light flashes.

■ If you hear a long chirp, you are going out of programming mode, please go back to Step 1.

■ If you want to change more options, go back to Step 1.

### Resetting the Programming Options to the factory default settings.

**Step1:** Press Buttons (I+II) simultaneously or Buttons (I+III) simultaneously for 2 seconds. Step 1 is confirmed by a car chirp and a one-time flashing of the parking light.

**Step2:** Press Button III three times. This is confirmed by a car chirp and parking light flash each time you press Button III. A few second later, your car will chirp and parking light flash three times rapidly. Your car is now set to all of the original factory default settings.

### Option Programming for Six Button(ONE WAY) Remotes

The procedures will be same as the 4 button remotes except the use of the different buttons.

Programming	6 Button Remote	4 Button Remote
Programming Menu 1	(Trunk+Start)-	(I+II)-
Programming Menu 2	(Trunk+Stop)-	(I+IV)-
Option Selection	(Stop)-	(IV)
Factory Setting	Lock	( I )
Option Selection	Unlock	( II )
Default Setting Selection	(Start)-	( III )

### Remote-Pager Programming Menu Options

#### Programming Menu #1 ( Door Lock Options )

	Feature	Factory Default Setting - Button I	Optional Setting - Button II
1- 1			
1- 2	Door Lock / Unlock Pulse Duration	0,8 sec	2,5 sec
1- 3			
1- 4	Driver's Priority Unlock	OFF	ON
1- 5	Double Pulse Unlock	OFF	ON
1- 6	Dome Light Factory Rearm	OFF	ON
1- 7			

#### Note

**1- 4** This feature unlocks the driver's side door lock with the first unlock pulse. A second unlock pulse is need to unlock the rest of the car doors.

**Important!** In order for this feature to operate, the installer must use the 2<sup>nd</sup> Unlock Wire (Or/Bk wire of Connector 4). Isolate the driver's door actuator from the rest of the other doors. Call us for the technical support if you are not sure about this.

### Programming Menu #2 (Security Options)

	Feature	Factory Default Setting - Button I	Optional Setting - Button II	Programming Method
				Remote controller
2-3	Passive Arming	Passive Locking, too	No Passive Locking	
2-4	Anti-jacking	OFF	ON	
2-5	Ignition Controlled Door Lock	OFF	ON	
2-6	Aux 1 Output	0.5 Sec	Latch	
2-7	Aux 2 Output	0.5 Sec	Latch	
2-8	Siren Duration	30 Sec	60 Sec	

	Feature	OFF	ON	Programming Method
2-9	Channel Expander	Non using of Channel Expander module	Using of Channel Expander module	Option Programmer (CM3-Series)
2-10	Passive Arming with the Channel Expander	When Option 2-9 is on		
		Non using of Passive Mode with remote	Using of Passive Mode with remote	

### Note

**2-4** With this option, Panic mode becomes Anti-Jacking mode. The differences between Panic mode and Anti-Jacking mode are :

	Panic Mode	Anti-Jacking Mode
Button	IV for 2 seconds	IV for 2 seconds
Siren	1.5 minutes	1.5 minutes
Installation required	Starter-Kill	Ignition-Kill
Starter Kill	Activated immediately	N/A
Ignition Kill	N/A	Activated immediately if key is not on. If key is on, activated in 30 seconds after pressing the Button IV

**2-5** With this option, the doors will lock after the ignition is turned on and unlock when the ignition is turned off.

### 2-6 & 2-7

You can program the duration between 1 to 99 seconds. You can program the "Latch Mode" also.

Contents	Setting	2-9	
		Off	On
2-6	off	Pluse	1-99, Latch
	on	Latch	
2-7	off	Pluse	1-99, Latch
	on	Latch	

**2-9** If you need more than 2 Aux outputs, you can interface the CM 3000 with Channel Expander for 7 Aux outputs. If you take this Channel Expander option and you turn on the Passive setting of the 2WFMR, the four buttons of the 2WFMR operate these 7 outputs instead of normal button functions such as arm/disarm or start/stop. Refer to the manual of the Channel Expander.

### 2-10

If you take the Channel Expander option of 2-9, the Passive setting of the remote will change the button functions to operate of the Channel Expander. The Passive setting of the remote will no longer work as the Passive Arming function. Therefore, if you need both Channel Expander and Passive Arming function, you need to choose this option.

Setting AUX No.	2-9		
	On		off
	Access to passive mode through a remote		
	Non setting of passive mode	Setting of passive mode	
AUX 1	Button <b>II</b>	Button <b>I</b>	Button <b>II</b>
AUX 2	Button <b>III</b>	Button <b>II</b>	Button <b>III</b>
AUX 3		Button <b>III</b>	
AUX 4		Button <b>IV</b>	
AUX 5		Button <b>II-</b>	
AUX 6		Button <b>III-</b>	
AUX 7		Button <b>IV-</b>	
Output	All outputs are connecting with Channel Expander through AUX1.		AUX 1, AUX 2

**Adjusting the Car Siren Volume:**

In order to decrease the chirping volume of the siren, cut the loop located on the siren.

**Adjusting the Shock Sensor Sensitivity:**

In order to the shock sensor sensitivity, turn the screw located on the sensor clockwise. In order to decrease the sensitivity, turn the screw located on the sensor counter-clockwise. Turning the screw just a small amount can make a big difference so make sure you recheck the sensitivity after each adjustment.