

**WIRELESS MICROPHONE
SYSTEM**

**INSTRUCTION
MANUAL**

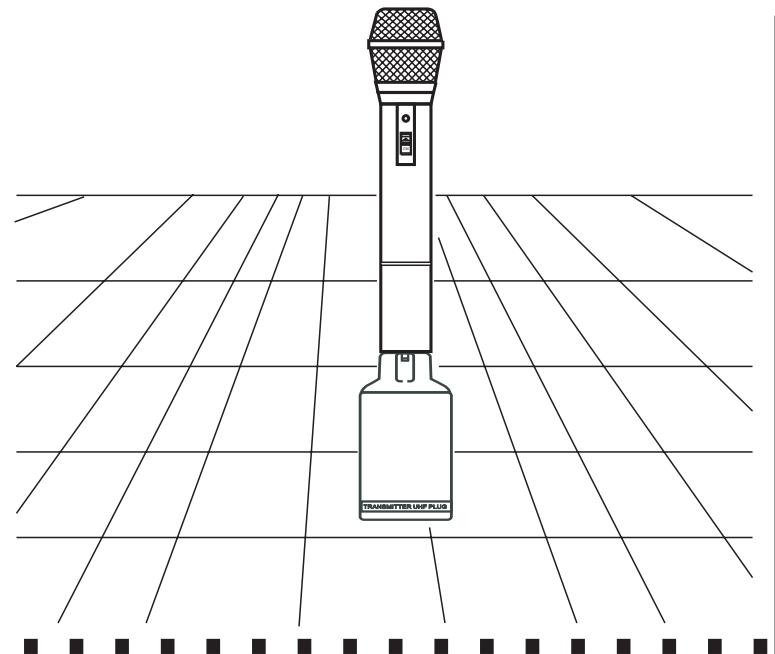

AW-8T



INTRODUCTION:

1. The model is Plug-on transmitter.
2. It is designed for turning the cable hand - held dynamic microphone into a wireless microphone.

FEATURE:

1. MIC.INPUT (XLR)
2. RELEASE BUTTON
3. 9V BATTERY CHAMBER
4. CHANNEL SWITCH
5. BOTTOM VIEW

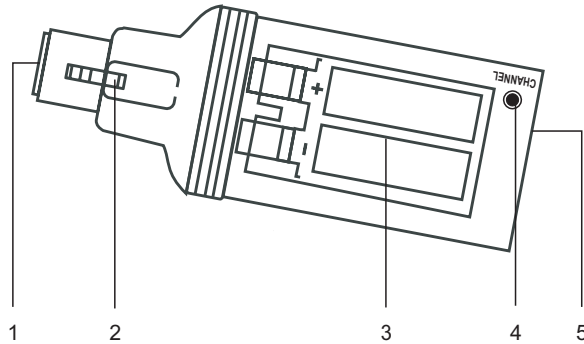

6. BATTERY LIGHT
7. POWER SWITCH

SPECIFICATION

TRANSMITTER PERFORMANCE SPECIFICATION:

MODEL: AW-8T		DATE:7,27,2001	TESTER:T.S.HER
NO.	ELECTRIC PARAMETER	SPECIFICATION	
1	Carrier Frequency Range	UHF 790-865 Mhz	
2	RF Power Output	5mW (TYPE)	
3	Spurious Emission	>45dBc	
4	Total Harmonic Distortion	≤ 1%	
5	Power Source	DC +9V	
6	Current	30mA	
7	Tone Osc.Frequency	32.768KHz	
8	Dimensions	117mm/4.6"	
9	Weight	80g(0.18lb)	

INSTRUCTION:

1. AFTER OPERATION THE MICROPHONE MUST BE SWITCHED OFF AS WELL. OTHERWISE THE BATTERIES WILL SOON BE EXHAUSTED. IN ORDER TO AVOID UNTUNEFUL CONSUMPTION OF THE INNER BATTERY: IF PILOT LAMP OF THE WIRELESS MICROPHONE (1) REMAINS LIGHTED, IT MEANS THAT THE BATTERY HAS NO MORE POWER: (2) THE LAMP MUST FLASH ONLY FOR THE TIME OF THE SWITCHING -ON; THIS INDICATES THAT THE MICROPHONE WORKS WELL.

WHEN SWITCHES THE POWER SWITCH TO "ON" POSITION, THEN THE POWER INDICATOR LIGHTS, INDICATES THE APPARATUS IS ON.
WHEN SWITCHES THE POWER SWITCH TO "OFF" POSITION, THEN THE POWER INDICATOR EXINDICATS THE APPARATUS IS OFF.

2. INSTALL BATTERY:
PLS. MAKE SURE THE POSITIVE/NEGATIVE BEFORE YOU REPLACEMENT BATTERIES.
3. WE CONGRATULATE YOU FOR THE CHOICE OF THIS EXCELLENT PROFESSIONAL APPARATUS MICROPHONE WHICH WILL GIVE YOU OUTSTANDING RESULTS AT THE HIGH FIDELITY. THE MICROPHONE SUIT FOR SCHOOL SPEECH, MEETING SPEECH, TEACHERS AND PERFORMER ON THE STAGE. TO AVOID OF PROBLEM LIKE WIRELESS MICROPHONE. THE BODY PACK MICROPHONE CONNECTION IN EVERY WORKING CONDITION.
4. IF YOU WANT TO HAVE A DIFFERENT FREQUENCY, SET THE RECEIVER AND TRANSMITTER POWER SW TO OFF BEFORE YOU DO.

BATTERY INSTALLATION:

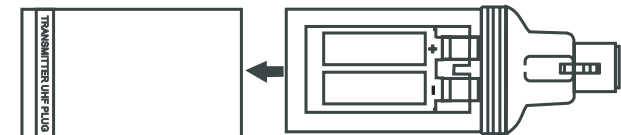
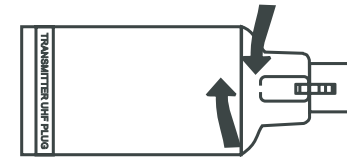

MICROPHONE CONNECTION

Please press firmly insure locking.

