



OWNER'S MANUAL

MOD-800R  
MOD-800H/MOD-800P/MOD-800LV/MOD-800HS/MOD-800G  
*WIRELESS MICROPHONE SYSTEM*



**SEIKAKU TECHNICAL GROUP LIMITED**  
NO. 1, Lane 17, Sec. 2, Han Shi West Road, Taichung 40151, Taiwan  
<http://www.altoproaudio.com> Tel: 886-4-22313737  
email: [alto@altoproaudio.com](mailto:alto@altoproaudio.com) Fax: 886-4-22346757

All rights reserved to ALTO. All features and content might be changed without prior notice. Any photocopy, translation, or reproduction of part of this manual without written permission is forbidden. Copyright ©2007 Seikaku Group

NF02682-1.3

[www.altoproaudio.com](http://www.altoproaudio.com)  
Version 1.3 DEC. 2007  
English

# IMPORTANT SAFETY INSTRUCTION



**TO REDUCE THE RISK OF ELECTRIC SHOCK PLEASE DO NOT REMOVE THE COVER OR THE BACK PANEL OF THIS EQUIPMENT. THERE ARE NO PARTS NEEDED BY USER INSIDE THE EQUIPMENT. FOR SERVICE, PLEASE CONTACT QUALIFIED SERVICE CENTERS.**

- This symbol, wherever used, alerts you to the presence of un-insulated and dangerous voltages within the product enclosure. These are voltages that may be sufficient to constitute the risk of electric shock or death.
- This symbol, wherever used, alerts you to important operating and maintenance instructions. Please read.
- Protective Ground Terminal
- AC mains (Alternating Current)
- Hazardous Live Terminal

ON: Denotes the product is turned on.  
 OFF: Denotes the product is turned off.

**CAUTION**  
 Describes precautions that should be observed to prevent damage to the product.

1. Read this Manual carefully before operation.
2. Keep this Manual in a safe place.
3. Be aware of all warnings reported with this symbol.
4. Keep this Equipment away from water and moisture.
5. Clean it only with dry cloth. Do not use solvent or other chemicals.
6. Do not damp or cover any cooling opening. Install the equipment only in accordance with the Manufacturer's instructions.
7. Power Cords are designed for your safety. Do not remove Ground connections! If the plug does not fit your AC outlet, seek advice from a qualified electrician. Protect the power cord and plug from any physical stress to avoid risk of electric shock. Do not place heavy objects on the power cord. This could cause electric shock or fire.
8. Unplug this equipment when unused for long periods of time or during a storm.
9. Refer all service to qualified service personnel only. Do not perform any servicing other than those instructions contained within the User's Manual.
10. To prevent fire and damage to the product, use only the recommended fuse type as indicated in this manual. Do not short-circuit the fuse holder. Before replacing the fuse, make sure that the product is OFF and disconnected from the AC outlet.

**WARNING**  
**To reduce the risk of electric shock and fire, do not expose this equipment to moisture or rain.**

**Dispose of this product should not be placed in municipal waste and should be separate collection.**

11. Move this Equipment only with a cart, stand, tripod, or bracket, specified by the manufacturer, or sold with the Equipment. When a cart is used, use caution when moving the cart / equipment combination to avoid possible injury from tip-over.

12. Permanent hearing loss may be caused by exposure to extremely high noise levels. The US. Government's Occupational Safety and Health Administration (OSHA) has specified the permissible exposure to noise level. These are shown in the following chart:

HOURS X DAY	SPL	EXAMPLE
8	90	Small gig
6	92	train
4	95	Subway train
3	97	High level desktop monitors
2	100	Classic music concert
1,5	102	
1	105	
0,5	110	
0,25 or less	115	Rock concert

The apparatus shall be connected to a mains socket outlet with a protective earthing connection.

The mains plug or an appliance coupler is used as the disconnect device, the disconnect device shall remain readily operable.

This device complies with Part 15 of the FCC Rules. Operation is subject to the following two conditions: (1) this device may not cause harmful interference, and (2) this device must accept any interference received, including interference that may cause undesired operation.

**WARNING:** changes or modifications not expressly approved by the party responsible for compliance could void the user's authority to operate the equipment.

# 8. WARRANTY

## 1. WARRANTY REGISTRATION CARD

To obtain Warranty Service, the buyer should first fill out and return the enclosed Warranty Registration Card within 10 days of the Purchase Date. All the information presented in this Warranty Registration Card gives the manufacturer a better understanding of the sales status, so as to provide a more effective and efficient after-sales warranty service. Please fill out all the information carefully and genuinely, miswriting or absence of this card will void your warranty service.

## 2. RETURN NOTICE

- 2.1 In case of return for any warranty service, please make sure that the product is well packed in its original shipping carton, and it can protect your unit from any other extra damage.
- 2.2 Please provide a copy of your sales receipt or other proof of purchase with the returned machine, and give detail information about your return address and contact telephone number.
- 2.3 A brief description of the defect will be appreciated.
- 2.4 Please prepay all the costs involved in the return shipping, handling and insurance.

## 3. TERMS AND CONDITIONS

- 3.1 **▲LTO** warrants that this product will be free from any defects in materials and/or workmanship for a period of 1 year from the purchase date if you have completed the Warranty Registration Card in time.
- 3.2 The warranty service is only available to the original consumer, who purchased this product directly from the retail dealer, and it can not be transferred.
- 3.3 During the warranty service, **▲LTO** may repair or replace this product at its own option at no charge to you for parts or for labor in accordance with the right side of this limited warranty.
- 3.4 This warranty does not apply to the damages to this product that occurred as the following conditions:
  - Instead of operating in accordance with the user's manual thoroughly, any abuse or misuse of this product.
  - Normal tear and wear.
  - The product has been altered or modified in any way.
  - Damage which may have been caused either directly or indirectly by another product / force / etc.
  - Abnormal service or repairing by anyone other than the qualified personnel or technician.

And in such cases, all the expenses will be charged to the buyer.  
 3.5 In no event shall **▲LTO** be liable for any incidental or consequential damages. Some states do not allow the exclusion or limitation of incidental or consequential damages, so the above exclusion or limitation may not apply to you.

3.6 This warranty gives you the specific rights, and these rights are compatible with the state laws, you may also have other statutory rights that may vary from state to state.

## 7. TECHNICAL SPECIFICATION

Model	MOD-800R
Channel	Multi-channels, up to 144 frequency presets for each frequency band
Frequency band	UHF 470-900 MHz (Dependent on applicable country regulations)
Receiver type	PLL UHF SYNTHESIZED
Frequency response	50 Hz-15 kHz ( $\pm 3$ dB)
Frequency stability	$\pm 0.005\%$ ( $-10^{\circ}\text{C}$ - $50^{\circ}\text{C}$ )
T.H.D.	1 kHz < 0.8%
Modulation mode	FM (F3E)
S/N Ratio	> 90 dB
Dynamic	> 100 dB
RF sensitivity	-100 dBm/30 dB SINAD
Audio output	Unbalanced 6.3mm phone jack 550mV; $\pm 20\text{kHz}$ deviation
Balance output	1.1 V, 20 kHz deviation
Power supply	DC 15V/ 500mA (AC 115V/230V 50/60Hz adaptor)
Dimensions (WxDxH)	210x155x44 mm; (8.2" x 6.1" x 1.7")
Weight	1.10 Kg

Model	MOD-800H
Oscillation mode	PLL UHF SYNTHESIZED
Carrier Frequency Band	UHF 470-900 MHz Dependent on applicable country regulations
Frequency Response	50 Hz-15 kHz ( $\pm 3$ dB)
Frequency Stability	$\pm 0.005\%$ ( $-10^{\circ}\text{C}$ ~ $50^{\circ}\text{C}$ )
T.H.D.	1 kHz < 0.8%
Modulation Mode	FM (F3E)
RF Output Power	5-50mW(adjustable 3 bands)
Dynamic	> 100 dB
Tone Frequency	30-33 kHz
Current Drain	100 mA
Max. Deviation	$\pm 35$ kHz
Battery	"AA" type x 2
Optional	Nickel hydrogen battery+charger
Mic. Capsule(Optional)	Condenser or Dynamic Capsule
Dimensions	277x $\phi$ 36.5mm (10.9"x $\phi$ 1.44")
Weight	0.246 Kg

Model	MOD-800P/MOD-800LV/MOD-800HS/MOD-800G
Oscillation mode	PLL UHF SYNTHESIZED
Carrier Frequency Band	UHF 470-900 MHz Dependent on applicable country regulations
Frequency Response	50 Hz-15 kHz ( $\pm 3$ dB)
Frequency Stability	$\pm 0.005\%$ ( $-10^{\circ}\text{C}$ ~ $50^{\circ}\text{C}$ )
T.H.D.	1 kHz < 0.8%
Modulation Mode	FM (F3E)
RF Output Power	5-50mW(adjustable 3 bands)
Dynamic	> 100 dB
Tone Frequency	30-33 kHz
Current Drain	100 mA
Max. Deviation	$\pm 35$ kHz
Battery	"AA" type x 2
Optional	Nickel hydrogen battery +charger
Mic. Capsule(Optional)	Condenser or Dynamic Capsule
Dimensions(WxDxH)	97 x 68 x 22 mm (3.82"x2.68" x 0.87")
Weight	0.090 Kg

## IN THIS MANUAL:

1. INTRODUCTION.....	1
2. FEATURES.....	3
3. CONTROL ELEMENTS.....	4
4. OPERATION .....	8
5. MODELLING TECHNOLOGY FOR WIRELESS MICROPHONES.....	13
6. ANNEX .....	15
7. TECHNICAL SPECIFICATIONS.....	20
8. WARRANTY.....	21

## 1. INTRODUCTION

Thank you for your purchasing the MOD-800 ▲LTO wireless system.

Your MOD-800 is based on a new revolutionary UHF PLL (phase loop locked) circuit which allows the simultaneous use of more than 144 channels (depending on your country regulations). The Receiver is provided with 2 antennas that constantly monitor the incoming RF (radio frequency) signal and send only the stronger RF signal to the MOD-800 Receiver. Your MOD-800 system is full of key features such as AUTO-SCAN function, battery level monitoring and others.

Enjoy your MOD-800 and make sure to read this Manual carefully before operation!

Depending on the options available your MOD-800 system consists of:

1. MOD-800R, PLL UHF Diversity Receiver

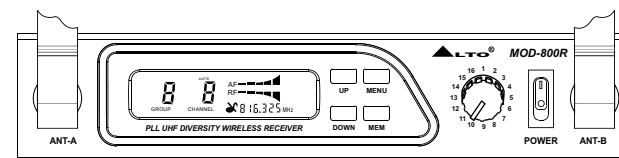

Either one of the following transmitters:

MOD-800H: It is a handheld transmitter with rubberised finished and level hi-fi microphone capsule.

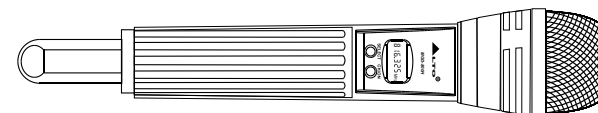

# 1. INTRODUCTION

Type: Dynamic Mic.

Frequency response: 50 Hz~16 kHz(±3 dB)

Impedance: 300 Ω ±20% at 1kHz

Sensitivity: -71 dB ±3 dB

Direction: Omni-directional

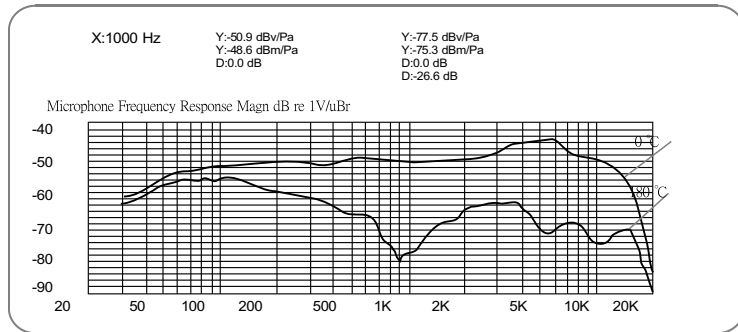
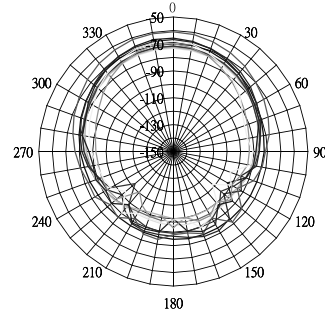

MOD-800P: A bodypack transmitter with belt clip. The bodypack transmitter will come with either:

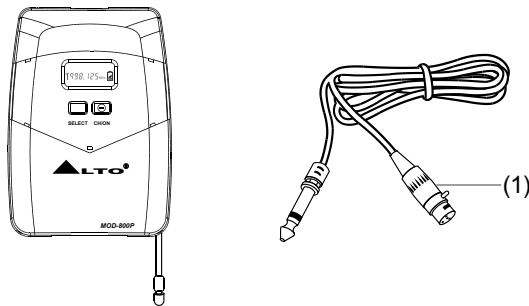

- (1). A cable to be connected to an electric guitar or bass.(MOD-800G)
- (2). A Lavalier Microphone. This is the little "bug" to be clipped on ties, shirts, nipples, etc.(MOD-800LV)
- (3). A Headset Microphone that is fit like a pair of sunglasses so that the Player has both hands free to play an instrument, dance, shot the Audience, etc.(MOD-800HS)

# 6. ANNEX

F8: 850.000-874.000(850-879)MHz

	Group1	Group2	Group3	Group4	Group5	Group6	Group7	Group8	Group9	Group10	Group11	Group12
1	850.125	850.325	850.525	850.725	850.925	851.125	851.325	851.525	851.725	851.925	852.125	852.325
2	852.525	852.725	852.925	853.125	853.325	853.525	853.725	853.925	854.125	854.325	854.525	854.725
3	854.925	855.125	855.325	855.525	855.725	855.925	856.125	856.325	856.525	856.725	856.925	857.125
4	857.325	857.525	857.725	857.925	858.125	858.325	858.525	858.725	858.925	859.125	859.325	859.525
5	859.725	859.925	860.125	860.325	860.525	860.725	860.925	861.125	861.325	861.525	861.725	861.925
6	862.125	862.325	862.525	862.725	862.925	863.125	863.325	863.525	863.725	863.925	864.125	864.325
7	864.525	864.725	864.925	865.125	865.325	865.525	865.725	865.925	866.125	866.325	866.525	866.725
8	866.925	867.125	867.325	867.525	867.725	867.925	868.125	868.325	868.525	868.725	868.925	869.125
9	869.325	869.525	869.725	869.925	870.125	870.325	870.525	870.725	870.925	871.125	871.325	871.525
10	871.725	871.925	872.125	872.325	872.525	872.725	872.925	873.125	873.325	873.525	873.725	873.925
11	874.125	874.325	874.525	874.725	874.925	875.125	875.325	875.525	<u>875.725</u>	<u>875.925</u>	<u>876.125</u>	<u>876.325</u>
12	876.525	876.725	876.925	877.125	877.325	877.525	877.725	877.925	878.125	878.325	878.525	878.725

Remark:

1. The values with underlines should be scanned manually by adjusting the UP/DOWN key.
2. The following channels can be used simultaneously without any interference.

- Group 1-1: 850.125      Group 1-10: 851.925
- Group 2-2: 852.725      Group 2-5: 859.925
- Group 3-4: 857.725      Group 2-6: 862.325
- Group 5-8: 867.725      Group 4-11: 874.725
- Group 8-6: 863.525      Group 8-8: 868.325

F9: 915.000-939.000(915-944)MHz

	Group1	Group2	Group3	Group4	Group5	Group6	Group7	Group8	Group9	Group10	Group11	Group12
1	915.125	915.325	915.525	915.725	915.925	916.125	916.325	916.525	916.725	916.925	917.125	917.325
2	917.525	917.725	917.925	918.125	918.325	918.525	918.725	918.925	919.125	919.325	919.525	919.725
3	919.925	920.125	920.325	920.525	920.725	920.925	921.125	921.325	921.525	921.725	921.925	922.125
4	922.325	922.525	922.725	922.925	923.125	923.325	923.525	923.725	923.925	924.125	924.325	924.525
5	924.725	924.925	925.125	925.325	925.525	925.725	925.925	926.125	926.325	926.525	926.725	926.925
6	927.125	927.325	927.525	927.725	927.925	928.125	928.325	928.525	928.725	928.925	929.125	929.325
7	929.525	929.725	929.925	930.125	930.325	930.525	930.725	930.925	931.125	931.325	931.525	931.725
8	931.925	932.125	932.325	932.525	932.725	932.925	933.125	933.325	933.525	933.725	933.925	934.125
9	934.325	934.525	934.725	934.925	935.125	935.325	935.525	935.725	935.925	936.125	936.325	936.525
10	936.725	936.925	937.125	937.325	937.525	937.725	937.925	938.125	938.325	938.525	938.725	938.925
11	939.125	939.325	939.525	939.725	939.925	940.125	940.325	940.525	940.725	940.925	941.125	941.325
12	941.525	941.725	941.925	942.125	942.325	942.525	942.725	942.925	943.125	943.325	943.525	943.725

## 6. ANNEX

F7: 798.000-822.000(798-827)MHz

	Group1	Group2	Group3	Group4	Group5	Group6	Group7	Group8	Group9	Group10	Group11	Group12
1	798.125	798.325	798.525	798.725	798.925	799.125	799.325	799.525	799.725	799.925	800.125	800.325
2	800.525	800.725	800.925	801.125	801.325	801.525	801.725	801.925	802.125	802.325	802.525	802.725
3	802.925	803.125	803.325	803.525	803.725	803.925	804.125	804.325	804.525	804.725	804.925	805.125
4	805.325	805.525	805.725	805.925	806.125	806.325	806.525	806.725	806.925	807.125	807.325	807.525
5	807.725	807.925	808.125	808.325	808.525	808.725	808.925	809.125	809.325	809.525	809.725	809.925
6	810.125	810.325	810.525	810.725	810.925	811.125	811.325	811.525	811.725	811.925	812.125	812.325
7	812.525	812.725	812.925	813.125	813.325	813.525	813.725	813.925	814.125	814.325	814.525	814.725
8	814.925	815.125	815.325	815.525	815.725	815.925	816.125	816.325	816.525	816.725	816.925	817.125
9	817.325	817.525	817.725	817.925	818.125	818.325	818.525	818.725	818.925	819.125	819.325	819.525
10	819.725	819.925	820.125	820.325	820.525	820.725	820.925	821.125	821.325	821.525	821.725	821.925
11	822.125	822.325	822.525	822.725	822.925	823.125	823.325	823.525	<u>823.725</u>	<u>823.925</u>	824.125	824.325
12	<u>824.525</u>	<u>824.725</u>	<u>824.925</u>	<u>825.125</u>	<u>825.325</u>	<u>825.525</u>	<u>825.725</u>	<u>825.925</u>	<u>826.125</u>	<u>826.325</u>	<u>826.525</u>	<u>826.725</u>

Remark:

1. The values with underlines should be scanned manually by adjusting the UP/DOWN key.
2. The following channels can be used simultaneously without any interference.

Group 1-1: 798.125	Group 1-10: 819.725
Group 2-2: 800.725	Group 2-5: 807.925
Group 3-4: 805.725	Group 2-6: 810.325
Group 5-8: 815.725	Group 4-11: 822.725
Group 8-6: 811.525	Group 8-8: 816.325

## 1. INTRODUCTION

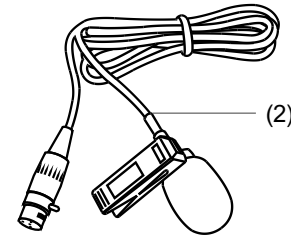

LM-10, Clip microphone  
Preset Impedance: 680 ohm  
Freq. Response: 50-12 kHz;  
Sensitivity: -65 dB ±3 dB at 1kHz  
Directional: Φ 12×180 mm(Φ 0.47"×7.1")  
Weight: 22g(0.049lb)

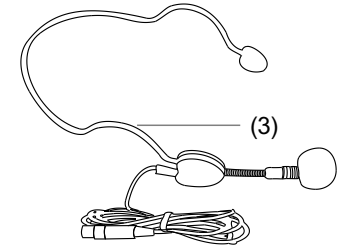

HM-38, Condenser microphone  
Preset Impedance: 600 ohm  
Freq. Response: 80-12 kHz;  
Sensitivity: -68 dB+/-3 dB at 1kHz;  
Directional: Uni-directional;  
Weight: 52g (0.12lb)

## 2. FEATURES

### - FEATURES OF MOD-800R, PLL UHF DIVERSITY RECEIVER

- ▲ User Friendly interface including a large blue back lighted display and an intuitive MENU system for easy operation.
- ▲ Auto Scan Function
- ▲ 2 Antennas and switching diversity circuit
- ▲ Selector for three different audio output levels depending of kind of mixer used
- ▲ Squelch control to minimize RF interferences

### - FEATURES OF MOD-800H AND MOD-800P/800LV/800HS/800G TRANSMITTERS

- ▲ Soft touch rubberised painting to avoid handling noise
- ▲ Rechargeable battery design
- ▲ Selector for three different output levels depending of kind of receiver used
- ▲ LCD display
- ▲ Battery status display
- ▲ Mute function (this function is very welcomed by Politicians...)
- ▲ Lock function to avoid miss action during a live performance

Each MOD-800 System complies with EMC regulations and includes 144 different channels.  
(Not all channels may be available in certain Countries depending on local regulations).

They are manufactured under ISO9000:2000, ISO/TS 16949:2002 quality management system.



### 3. CONTROL ELEMENTS

Ok, enough with numbers. Let's start to familiarize with your MOD-800 System. First of all, the MOD-800R Receiver:

#### 3.1 MOD-800R, PLL UHF Diversity Receiver

THE FRONT PANEL

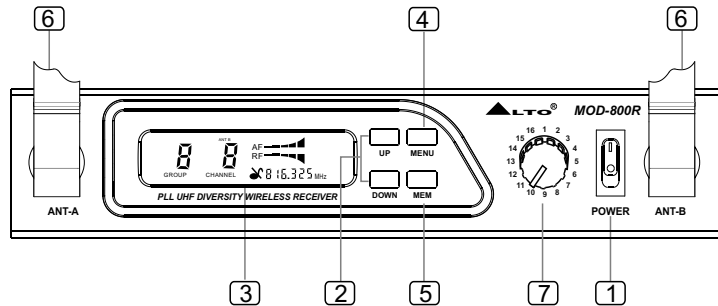

#### 1 Power Switch

It switches your MOD-800R ON and OFF.

#### 2 UP/DOWN Keys

You can adjust the right values through these two keys once the MENU is activated.

#### 3 DISPLAY

All the key functions of your MOD-800 Receiver are monitored through this big, amazing, blue back lighted display such as: Radio Signal, Audio Signal, Battery life (absolutely with some little magic you can see the battery life of the transmitter directly on the receiver!), group value, channel value and the selected frequency.

#### 4 MENU Key

Via this key you can activate the desired function.

#### 5 MEM Key

You can enter the selected frequency via this key, moreover you can also activate the AUTO-SCAN function via the same key.

#### 6 Antenna Input Sockets

You must connected the two cute antennas you found in the box if you want to get proper RF transmission.

#### 7 Models Preset Knob

Via this knob, you can select the desired effect. There are totally 16 options for your operation. For more details, please refer to chapter 5.

### 6. ANNEX

F5: 702.000-726.000(702-731)MHz

	Group1	Group2	Group3	Group4	Group5	Group6	Group7	Group8	Group9	Group10	Group11	Group12
1	702.125	702.325	702.525	702.725	702.925	703.125	703.325	703.525	703.725	703.925	704.125	704.325
2	704.525	704.725	704.925	705.125	705.325	705.525	705.725	705.925	706.125	706.325	706.525	706.725
3	706.925	707.125	707.325	707.525	707.725	707.925	708.125	708.325	708.525	708.725	708.925	709.125
4	709.325	709.525	709.725	709.925	710.125	710.325	710.525	710.725	710.925	711.125	711.325	711.525
5	711.725	711.925	712.125	712.325	712.525	712.725	712.925	713.125	713.325	713.525	713.725	713.925
6	714.125	714.325	714.525	714.725	714.925	715.125	715.325	715.525	715.725	715.925	716.125	716.325
7	716.525	716.725	716.925	717.125	717.325	717.525	717.725	717.925	718.125	718.325	718.525	718.725
8	718.925	719.125	719.325	719.525	719.725	719.925	720.125	720.325	720.525	720.725	720.925	721.125
9	721.325	721.525	721.725	721.925	722.125	722.325	722.525	722.725	722.925	723.125	723.325	723.525
10	723.725	723.925	724.125	724.325	724.525	724.725	724.925	725.125	725.325	725.525	725.725	725.925
11	726.125	726.325	726.525	726.725	726.925	727.125	727.325	727.525	727.725	727.925	728.125	728.325
12	728.525	728.725	728.925	729.125	729.325	729.525	729.725	729.925	730.125	730.325	730.525	730.725

F6: 740.000-764.000(740-769)MHz

	Group1	Group2	Group3	Group4	Group5	Group6	Group7	Group8	Group9	Group10	Group11	Group12
1	740.125	740.325	740.525	740.725	740.925	741.125	741.325	741.525	741.725	741.925	742.125	742.325
2	742.525	742.725	742.925	743.125	743.325	743.525	743.725	743.925	744.125	744.325	744.525	744.725
3	744.925	745.125	745.325	745.525	745.725	745.925	746.125	746.325	746.525	746.725	746.925	747.125
4	747.325	747.525	747.725	747.925	748.125	748.325	748.525	748.725	748.925	749.125	749.325	749.525
5	749.725	749.925	750.125	750.325	750.525	750.725	750.925	751.125	751.325	751.525	751.725	751.925
6	752.125	752.325	752.525	752.725	752.925	753.125	753.325	753.525	753.725	753.925	754.125	754.325
7	754.525	754.725	754.925	755.125	755.325	755.525	755.725	755.925	756.125	756.325	756.525	756.725
8	756.925	757.125	757.325	757.525	757.725	757.925	758.125	758.325	758.525	758.725	758.925	759.125
9	759.325	759.525	759.725	759.925	760.125	760.325	760.525	760.725	760.925	761.125	761.325	761.525
10	761.725	761.925	762.125	762.325	762.525	762.725	762.925	763.125	763.325	763.525	763.725	763.925
11	764.125	764.325	764.525	764.725	764.925	765.125	765.325	765.525	765.725	765.925	766.125	766.325
12	766.525	766.725	766.925	767.125	767.325	767.525	767.725	767.925	768.125	768.325	768.525	768.725

## 6. ANNEX

F3: 572.000-596.000(572-598)MHz

	Group1	Group2	Group3	Group4	Group5	Group6
1	572.125	572.325	572.525	572.725	572.925	573.125
2	573.325	573.525	573.725	573.925	574.125	574.325
3	574.525	574.725	574.925	575.125	575.325	575.525
4	575.725	575.925	576.125	576.325	576.525	576.725
5	576.925	577.125	577.325	577.525	577.725	577.925
6	578.125	578.325	578.525	578.725	578.925	579.125
7	579.325	579.525	579.725	579.925	580.125	580.325
8	580.525	580.725	580.925	581.125	581.325	581.525
9	581.725	581.925	582.125	582.325	582.525	582.725
10	582.925	583.125	583.325	583.525	583.725	583.925
11	584.125	584.325	584.525	584.725	584.925	585.125
12	585.325	585.525	585.725	585.925	586.125	586.325

F4: 638.000-662.000(638-664)MHz

	Group1	Group2	Group3	Group4	Group5	Group6
1	638.125	638.325	638.525	638.725	638.925	639.125
2	639.325	639.525	639.725	639.925	640.125	640.325
3	640.525	640.725	640.925	641.125	641.325	641.525
4	641.725	641.925	642.125	642.325	642.525	642.725
5	642.925	643.125	643.325	643.525	643.725	643.925
6	644.125	644.325	644.525	644.725	644.925	645.125
7	645.325	645.525	645.725	645.925	646.125	646.325
8	646.525	646.725	646.925	647.125	647.325	647.525
9	647.725	647.925	648.125	648.325	648.525	648.725
10	648.925	649.125	649.325	649.525	649.725	649.925
11	650.125	650.325	650.525	650.725	650.925	651.125
12	651.325	651.525	651.725	651.925	652.125	652.325



## 3. CONTROL ELEMENTS

### THE REAR PANEL

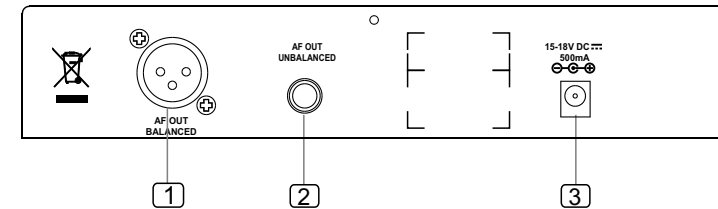

#### 1 Audio Output XLR

To connect a balanced cable with XLR connector (we forgot to tell you that although your MOD-800 system is wireless, you will still need to connect the receiver to your Mixing Desk and to a wall plug !)

#### 2 Audio Output Jack

To be used with an unbalanced cable and standard 1/4" mono jack.

#### 3 DC Input

You can connect the supplied AC Adapter to this socket.

### 3.2 MOD-800H, Handheld Transmitter

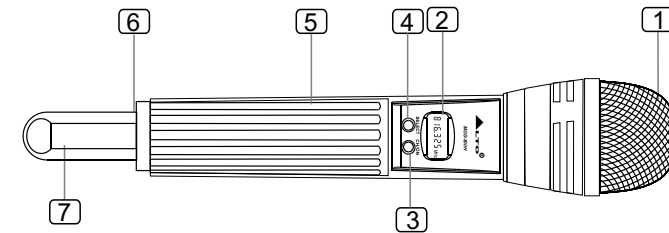

#### 1 Front Grill

This spring steel mesh grill will protect the microphone capsule during a live performance. Especially made for heavy metal players, alcohol, drugs, etc.

#### 2 LCD Display

This nice blue LCD will indicate the current operation status.

#### 3 CH/ON Key

If you press this key for a few seconds, your Transmitter will be switched ON or OFF. Once you have switched the unit ON, just press this key again slightly and you can edit various parameters, such as CHANNEL, GROUP, RF POWER LEVEL and LOCK/UNLOCK. Once you are in the LOCK position, no further operation is allowed. And in a few seconds, the display will show the current selected frequency (In MHZ). Battery level will also be shown.



### 3. CONTROL ELEMENTS

#### 4 SELECT Key

Once you are in operation mode, you can access this key to edit certain parameters. Press this key for a few seconds and the unit will enter in the MUTE mode. (In this way, you can tell your Bass Player what you think about the Sound Engineer without anybody knowing that!). Press it again for a few seconds and you will unmute the unit.

#### 5 Battery Compartment

This unit may be powered from one pair of dry or rechargeable batteries, um3 size AA 1.5V.

#### 6 Charge Jack

With the rechargeable batteries putting inside, use the charger supplied to recharge the batteries.

※Note: This charger is for buyer's option. You can buy it from your dealer.

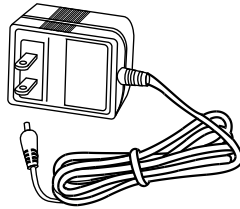

#### 7 Antenna

The Antenna of your MOD-800H is integrated in the microphone body. Please do not cover the antenna for optimal RF transmission. We also include 7 different color antenna covers for multiple operation of frequency.

#### 3.3 MOD-800P/800LV/800HS/800G, Body Pack Transmitter

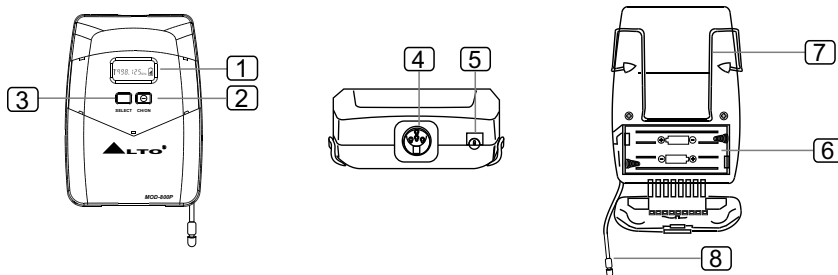

### 6. ANNEX

#### Frequency Band Selection

Most countries closely regulate the radio frequencies used in the transmission of wireless information. These regulations state which devices can use which frequencies, and help to limit the amount of RF (radio frequency) interference in all wireless communications. To be flexible enough to operate worldwide, MOD-800R Wireless receivers are available in a number of models, each with a unique frequency range. Each frequency range, or band, spans up to 24 MHz of the wireless broadcast spectrum. Available bands are:

- F1:470.000-494.000(470-496)MHz
- F2:518.000-542.000(518-544)MHz
- F3:572.000-596.000(572-598)MHz
- F4:638.000-662.000(638-664)MHz
- F5:702.000-726.000(702-731)MHz
- F6:740.000-764.000(740-769)MHz
- F7:798.000-822.000(798-827)MHz
- F8:850.000-874.000(850-879)MHz
- F9:915.000-939.000(915-944)MHz

F1: 470.000-494.000(470-496)MHz

	Group1	Group2	Group3	Group4	Group5	Group6
1	470.125	470.325	470.525	470.725	470.925	471.125
2	471.325	471.525	471.725	471.925	472.125	472.325
3	472.525	472.725	472.925	473.125	473.325	473.525
4	473.725	473.925	474.125	474.325	474.525	474.725
5	474.925	475.125	475.325	475.525	475.725	475.925
6	476.125	476.325	476.525	476.725	476.925	477.125
7	477.325	477.525	477.725	477.925	478.125	478.325
8	478.525	478.725	478.925	479.125	479.325	479.525
9	479.725	479.925	480.125	480.325	480.525	480.725
10	480.925	481.125	481.325	481.525	481.725	481.925
11	482.125	482.325	482.525	482.725	482.925	483.125
12	483.325	483.525	483.725	483.925	484.125	484.325

F2: 518.000-542.000(518-544)MHz

	Group1	Group2	Group3	Group4	Group5	Group6
1	518.125	518.325	518.525	518.725	518.925	519.125
2	519.325	519.525	519.725	519.925	520.125	520.325
3	520.525	520.725	520.925	521.125	521.325	521.525
4	521.725	521.925	522.125	522.325	522.525	522.725
5	522.925	523.125	523.325	523.525	523.725	523.925
6	524.125	524.325	524.525	524.725	524.925	525.125
7	525.325	525.525	525.725	525.925	526.125	526.325
8	526.525	526.725	526.925	527.125	527.325	527.525
9	527.725	527.925	528.125	528.325	528.525	528.725
10	528.925	529.125	529.325	529.525	529.725	529.925
11	530.125	530.325	530.525	530.725	530.925	531.125
12	531.325	531.525	531.725	531.925	532.125	532.325



## 5. MODELLING TECHNOLOGY

Here is a List and description of the MODELS available on the ▲LTO Receivers:

**MODEL 1: FLAT-** In this position, the Modeller is in bypass mode. The ▲LTO Modeller is not adding any character to the Audio Output

**MODEL 2: CONFERENCE-** To be used during Meetings. Especially made for speech and to avoid the typical boominess of many wireless microphones used for such purpose.

**MODEL 3: BROADCAST-** This Model will add a certain character to the signal. It is typical of the Male Announcers through a solid state Transmitter.

**MODEL 4: WARMTH-** Good for Lead Vocalist Male and Female. It will make the Male voice warmer and the Female voice more body.

**MODEL 5: DE-ESSER-** The name tells everything. Use it to de-emphasize the sibilants, like the letter sound 's', for example, from your vocals.

**MODEL 6: VINTAGE RADIO-** Old tube based Receivers made the Announcer voice sound like... yeah, we call it Vintage. Try it for a smooth satin voice. Ideally used for speech, but we found some other neat applications in the studio as well!

**MODEL 7: MID-WARMTH,** a moderate voice enhancement making use of Bass enhancer.

**MODEL 8: GROOVY-** to add a touch of groove to Male and Female Lead Vocalist. Perfect for Blues.

**MODEL 9: SHARP-** makes human voice quite crispy. Perfect for voice poor in high frequencies or if you get a cold...

**MODEL 10: KARAOKE-** yes, microphones are used in a very peculiar way in Karaoke Bars and Venues. Usually the sound systems there are poor. Use this Model to add high frequencies and have your voice sound like a Pro's!

**MODEL 11: PIANO BAR-** it similar to the Karaoke Model but we have also added key low frequencies to give the voice more body.

**MODEL 12: HEAVY METAL-** This model will make your voice sound very aggressive. Good for Rock & Roll and if you have an argument with your Mother in law...

**MODEL 13: DISCO-** It is similar to the Heavy Metal model but more tailored for Disco Music.

**MODEL 14: CHOIR-** Selected frequencies have been manipulated to make this Model suitable for more than one vocalist when singing in a choir

**MODEL 15: FEMALE VOICE-** Female Singers voices present a frequency response that is quite different from the Male voice. This Model gently adds certain low frequencies to make the female voice more consistent and at the same time will make the highest frequencies of the female voice more sparkling and defined.

**MODEL 16: PIANO BAR CHOIR-** It is a combination of the Karaoke Model and the Piano Bar Model. Good when more than one voice is singing along together.



## 3. CONTROL ELEMENTS

### 1 LCD Display

This nice blue LCD will indicate the current operation status.

### 2 CH/ON Key

If you press this key for a few seconds, your Transmitter will be switched ON or OFF. Once you have switched the unit ON, just press this key again slightly and you can edit various parameters such as CHANNEL, GROUP, RF POWER LEVEL and LOCK/UNLOCK. Once you are in the LOCK position no further operation is allowed. And in a few seconds, the display will show the current selected frequency (in MHZ). Battery level will also be shown.

### 3 SELECT Key

Once you are in operation mode, you can access this key to edit certain parameters. Press this key for a few seconds and the unit will enter in the MUTE mode. (In this way, you can tell your Bass Player what you think about the Sound Engineer without everybody knowing that!). Press it again for a few seconds and you will unmute the unit.

### 4 Mini 4P Connector

This connector is used to connect the unit with the clip microphones. for example, HM-38 condenser microphone or LM-10 clip microphone.

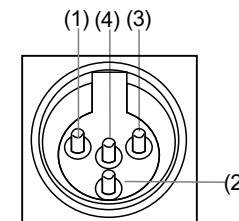

Pin 1, GND

Pin 2, Phantom power supply for Condenser microphone

Pin 3, for Guitar, bass and keyboards

Pin 4, for Dynamic or Condenser microphone

### 5 Charge Jack

With the rechargeable batteries put inside, use the charger supplied to recharge the batteries.

### 6 Battery Compartment

This unit may be powered from one pair dry or rechargeable batteries, Um3 size AA 1.5V.

### 7 Belt Clip

It is the detachable belt clip for easy carry during the live applications.

### 8 Antenna

It is a flexible antenna. To get effective transmission, never cover the antenna with hand, clothes, etc. during operation, and always position the transmitter nearby the receiver.





## 4. OPERATION

OK, if so far you remember all the functions and features of your MOD-800 system you are ready to operate the Unit. Let's start from the Receiver:

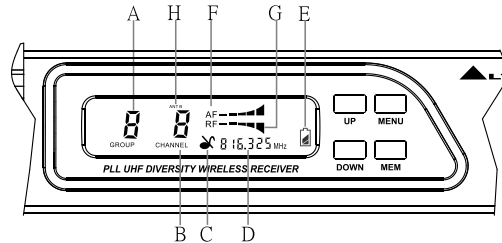
### 4.1 For the MOD-800R, PLL UHF Diversity Receiver



- A. This indicates the Frequency Group. There are 12 Groups and each Group includes 12 different channels (frequencies).
- B. This indicates the Channel Number. There are 12 channels for each one of the 12 Groups for a total of 144 channels.
- C. MUTE: If the Display shows , the Mute function is disengaged. If the display shows , the Mute function is engaged.
- D. This shows the selected frequency.
- E. This shows you the remaining life of the Battery of your Transmitter. 3 segments means full life, 1 segment means it is time to replace or recharge the battery. If this icon disappeared, it means that your transmitter is switched OFF.
- F. This bar(AF) indicates the level of the audio signal coming into the Receiver.
- G. This bar(RF) indicates the level of radio signal coming into the Receiver.
- H. This indicates which of the 2 antennas is operating. Radio signal will automatically switch from Ant 1 to Ant 2, indicating that the diversity circuit is operating properly.

- And now, let's see the four keys in detail:

**MEM key:** The first function of this key is to activate the AUTO-SCAN function. Suppose that you have more than one ▲LTO transmitter in front of you with your MOD-800R Receiver and you want to start to operate one of them with your MOD-800 Receiver.

First of all, you should turn your Transmitter ON, then with your MOD-800R Receiver turned ON, press the MEM key at least for one second. Your MOD-800R will automatically look for the frequency where your ▲LTO Transmitter is operating. It will scan all the 12 Groups and Channels for a total of 144 frequencies available.

## 5. MODELLING TECHNOLOGY

-Modelling Technology for Wireless Microphones.

This document applies to all ▲LTO Wireless Receivers used in conjunction with ▲LTO Handheld and Bodypack Transmitters

**Fundamentals:** ▲LTO has created and integrated a wireless microphone system offering 16 modelling presets resulting in a range of tonal response for a wide variety of applications. Until this innovative introduction made for the first time in the world in a wireless system by ▲LTO, wireless systems consisting of receiver and microphone transmitters produced a single sound pattern. Each microphone capsule design, because of the laws of physics, features its own frequency response and adds a certain tonal colour to the signal it transmits. If you do not like the colour added, you must change the microphone section of your transmitter, much like a painter chooses a different colour from his palate. Many brands today offer several different microphone capsules for their wireless systems but this flexibility is far behind the wide choice of tones or "models", as we call them at ▲LTO. In fact, a specific model of wireless microphone may be used by a male vocalist or female vocalist during a live performance, by a Priest in a church service, by a speaker during a seminar, by and aerobics teacher during a training lesson, by a DJ, by a choir, by an announcer, by an auction director, we could go on and on forever with endless applications.

It is now evident that each one of these users would benefit from a different tone or "model". But even the same user would like to get a different voicing or "model" depending on the style he is singing. What model serves the music best? It's fair to say that it will be different whether he's singing Rock, Blues, or Folk and, of course can also change from song to song. It is unlikely to buy several different microphone capsules in order to get different tone or "model" depending of the kind of use of performance. This would be unpractical, since it would be impossible to change a microphone capsule during a performance, not to mention the cost involved.

▲LTO has therefore created and integrated in some of its wireless receivers a range of MODELS. Using these 16 different MODELS the user can select different sound patterns simply with the turn of one knob. There are preset MODELS for male and female Vocalists, DJ, Speakers, Announcers, and more. In a few words, with the ▲LTO modelling technology applied to wireless systems, the User can "fine tune" the sound of his microphone in 16 different ways.



## 4. OPERATION

### - LOCK Function

You don't want accidental change of frequency or other setting in the middle of a performance, do you? Any miss-operation during a live performance can be easily avoided thanks to the LOCK function. With the LOCK function ON no further change of setting is allowed until the Transmitter is unlocked. To access the LOCK Menu, press the CH/ON key four times and then press the SELECT key to lock or unlock the Transmitter Settings. Your choice of setting will automatically be saved into the Transmitter in a few seconds. The blue display shows "lock" and "unlock" depending on the operating mode.



Fig 10: LOCK

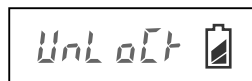

Fig 11: UNLOCK

### - Mute Function

Sometimes, there are things that you want to tell to your Friends on stage or your nearby Companion during a Meeting but not necessarily to the rest of the world especially if you are ON LIVE on CNN... A smart feature on your Transmitter allows you to easily MUTE the microphone so you are free to talk to the people next to you without the rest of the world hearing what you say . To enter into MUTE function simply press the SELECT key for a few seconds and the Transmitter will mute any audio signal going to the Receiver. Press SELECT again for a few seconds and you will UNMUTE the Transmitter.



## 4. OPERATION

During this process, the audio output will be muted and the display will show you the Group Number scanned, the channel number scanned and the frequency that is being scanned. Once the transmitter frequency has been found, the display will flash and the RF bar indicator and Battery life icon will appear. Press MEM again slightly and such frequency will be stored into your MOD-800R Receiver. Please note that frequencies can be scanned manually using the UP/DOWN key. See the Annex for more details.

**MENU key:** This key activates several functions:

Press this key slightly once and you will get into the MANUAL SELECT for the 144 frequencies. When the GROUP indicator is flashing, you can press the UP/DOWN keys to select manually the desired Group. Then you can press the MEM key to store this setting.

Press the MENU key twice and the CHANNEL indicator will flash. Use the UP/DOWN keys to selected the desired channel and then press MEM key to store this setting.

Press the MENU key three times and you can adjust the OUTPUT LEVEL. Using the UP/DOWN keys you have the choice to select three different levels:

- PL 0 indicates that the output level is 1.1V
- PL 1 indicates that the output level is 575mV
- PL 2 indicates that the output level is 250mV



Fig 1

Note: This function is only available when using the XLR balanced output.

Press the MENU key four times and you will get into the MUTE function. Use the UP/DOWN keys to mute/unmute the Unit.



Fig 2 mute function off



Fig 3 mute function on

Press the MENU key five times and you will activate the SQUELCH function. To squelch or not to squelch, this is the issue...

Squelch is a complicated name to express a simple conce pt: The threshold above or below that a signal is made pass through the receiver or not.



## 4. OPERATION

No.	Squelch Threshold
1	-100 dB
2	-96 dB
3	-93 dB
4	-90 dB
5	-87 dB
6	-85 dB
7	-83 dB
8	-81 dB
9	-79 dB
10	-77 dB

Table

### 4.2 For the MOD-800H/800P/800LV/800HS/800G transmitters

Press the CH/ON key for a few seconds and the transmitter will be powered ON.

At this point the blue back lighted display will show:

- The frequency at which the unit is operating
- The Battery Status



Fig 4



Fig 5

And now that you know how to operate your MOD-800R Receiver, let's learn how to use the MOD-800 Transmitters. The following instructions apply both to the handheld version and to the bodypack version.

There are 2 keys on the Transmitter labelled CH/ON and SELECT.

With the Transmitter switching ON, you can slightly press the CH/ON key again and you will access to the following parameters:

- Preset Group



Fig 6

- Preset Channel

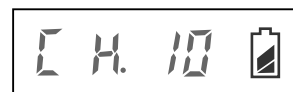

Fig 7



## 4. OPERATION

Note: Why ▲LTO wireless systems come with 144 different frequencies? Not because you will need to use 144 different microphones at the same time. It is unlikely that you will use more than 8 systems at the same time so why 144 frequencies? This mainly depends on Countries regulations. We offer frequencies from 470 to 900 MHZ. Some of these frequencies are illegal in certain Countries and vice versa. Offering such a wide range of frequencies we make sure that each single Country on the planet will have more than enough choice of frequencies available. Not only: A certain frequency is close to the frequency generated by lighting equipment, a computer, a fax machine and so on. Therefore, thanks to the large number of frequencies available you can easily switch to another frequency that is interference-free.

In your Transmitter, there are 12 frequency bands or GROUPS. Each Group contains 12 channels according to EMC regulations. To select a Group you must first switch your Transmitter ON by pressing the CH/ON key for a few seconds until you hear the beep and the blue display is lighted. Then press the CH/ON key again slightly and you will access the GROUP menu. At this point use the SELECT key to change the GROUP value from 1 to 12. Now, to access the CHANNEL menu, press again slightly the CH/ON key two times and use the SELECT key to change frequency from 1 to 12. Your setting will be automatically saved in a few seconds and the display will go back to the main menu showing the operating frequency.

Note: Once you have changed the operating frequency on your Transmitter, you need to activate the SCAN function in your MOD-800R Receiver. In this way the Receiver will synchronize automatically on the Transmitter frequency.

### - RF Output Power Select

Your Transmitter can operate on three different levels of output power. These are different from the Handheld Model and the Bodypack model.

For the Handheld model the levels are

- PL 0, the output power is 0 dBm
- PL 1, the output power is 5 dBm
- PL 2, the output power is 10 dBm

And for the Bodypack version the levels are

- PL 0, the output power is 0 dBm
- PL 1, the output power is 5 dBm
- PL 2, the output power is 10 dBm

position the transmitter nearby the receiver.