

UHF-10

UHF DIVERSITY WIRELESS MICROPHONE SYSTEM

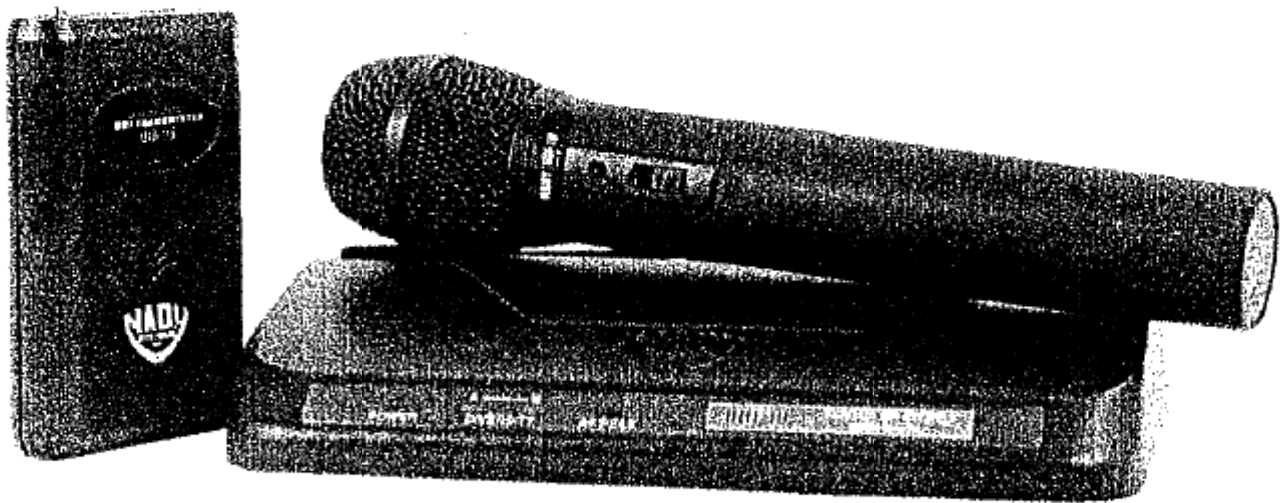

UHF-10 RECEIVER

UH-10 HANDHELD MICROPHONE

OWNER'S MANUAL

CONTENTS

CONTENTS	1
INTRODUCTION	2
UHF 10 RECEIVER	3
UH-10 HANDHELD MICROPHONE	5
UB-10 BODYPACK TRANSMITTER	7
SPECIFICATIONS	11
SERVICE	12

LICENSING REQUIREMENTS

This equipment complies with Part 74 of the FCC Rules.

A license is required for operation subjective device will be issued only to the following:

- (1) A licensed of an AM, FM, TV, or international broadcast station or low power TV station. Low power auxiliary stations will be licensed for used with a specific broadcast or low power TV station or combination of stations licensed to the same licensee within the same community.
- (2) A broadcast network entity.
- (3) A cable television system operator who operates a cable system that produces program material for origination or access cablecasting as defined in §76.5(r)
- (4) Motion picture producers as defined in §74.801.
- (5) Television program producers as defined in §74.801.
- (6) Licensees an conditional licensees of stations in the Multipoint Distribution service and Multichannel Multipoint Distribution Service as defined in §21.2 of this chapter, or entities that hold an executed lease agreement with an MDS or MMDS licensee or conditional licensee or with an Instructional Television Fixed service licensee or permittee.

INTRODUCTION

Thank you for purchasing a Nady UHF 10 Diversity Wireless Microphone System and congratulations on your choice. The UHF 10 is the best performance and price value available in UHF wireless systems and is loaded with features:

- Clear channel operation on the wide open, uncluttered UHF band for interference-free performance in any application or locale
- Nady's proprietary companding circuitry for an industry best 120dB Dynamic Range, and the clearest, most natural sound available
- Tone Squelch™ for locking out potential interference
- Choice of transmitters:
 - UB-10 Bodypack with unique 3-way switch for selecting input type: instrument (guitar, bass, etc.), headmic™ headworn mic, or lavalier/lapel mic
 - UH-10 Handheld microphone with a powerful neodymium cartridge that delivers unsurpassed audio, minimal handling noise and enhanced feedback rejection
- UHF 10 receiver with DigiTRU Diversity™ for maximum range and dropout protection, full LED indicators, both 1/4" unbalanced and XLR balanced outputs, and special circuitry for noiseless transmitter ON/OFF switching

UHF 10 RECEIVER

1. Powering the Receiver

Plug the **12V AC/DC ADAPTER (12)** provided into the **DC INPUT JACK (6)** on the back of the receiver. Then plug the power supply into an AC outlet. (Note: Any DC source with 300mA capability can also be used.) Press the **POWER SWITCH (5)** once to turn on the receiver. The **POWER ON LED (1)** will now light and the receiver is operational.

2. Antennas

Extend **TELESCOPIC ANTENNAS (4)** fully to obtain maximum range. Optimal antenna position is 45 degrees from the receiver (at 90 degrees from each other).

3. Squelch Adjustment

In normal operation, the **SQUELCH CONTROL (8)** should be set fully clockwise to the factory preset RF level (Max. Sens.). However, in areas of high RF activity, the squelch (or mute, as it is sometimes called) may need to be adjusted to compensate for the adverse conditions in a particular location. If, with the transmitter off, the receiver's A and/or B **DIVERSITY LED INDICATORS (2)** flicker or stay on, the squelch control should be turned counterclockwise until the A and/or B LEDs extinguish. When the squelch is properly adjusted, the A and/or B LEDs will only light when the system transmitter is turned on. Turning the squelch control too far counterclockwise will reduce the range, but yield a quieter squelch (mute) function.

During operation, especially at ranges greater than 75 feet, one or the other of the A or B LEDs may extinguish briefly. This is normal—the unit's DigiTRU Diversity™ reception ensures that the received audio will not be interrupted. When both LEDs extinguish, the transmitter is out of range for that given location, and the user should move closer to the receiver to re-establish the radio link.

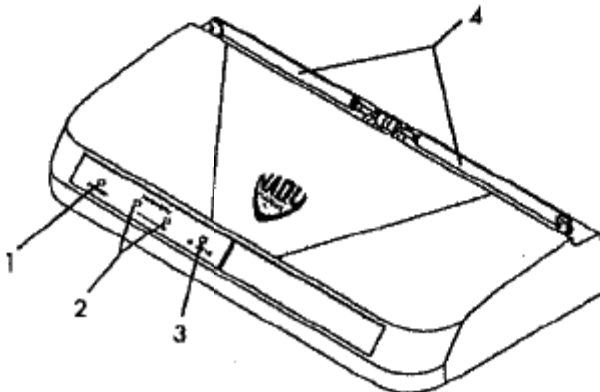

1. POWER ON LED INDICATOR
2. DIVERSITY LED INDICATORS
3. AF PEAK LED INDICATOR
4. TELESCOPIC ANTENNAS

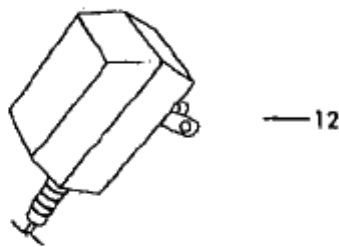
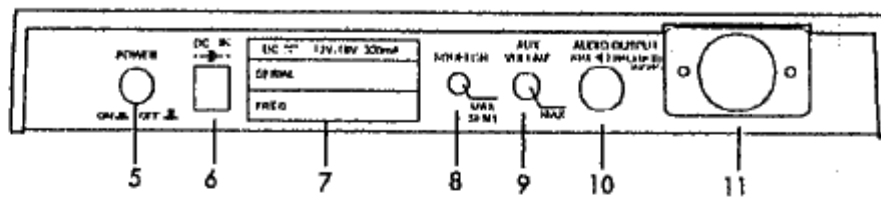

5. POWER SWITCH
6. DC INPUT JACK
7. FREQUENCY LABEL
8. SQUELCH CONTROL
9. AUX VOLUME CONTROL
10. AUX AUDIO OUTPUT
11. BALANCED MIC AUDIO OUTPUT XLR
12. 12V AC/DC ADAPTER

4. Connecting the Audio Output

The UHF 10 receiver provides both a fixed mic level **BALANCED MIC AUDIO OUTPUT XLR (11)** and an adjustable line level **AUX AUDIO OUTPUT 1/4" jack (10)**.

(Note: As when making any connection, make sure the amplifier or mixing board volume is at the minimum level before plugging in the receiver to avoid possible sound system damage.)

Instrument Connection (using the UB-10 transmitter in the "Instrument" setting)

Insert an audio cord with a 1/4" mono phone plug in the **AUX AUDIO OUTPUT JACK (10)** on the rear panel of the receiver. Plug the other end of the cord into an amplifier, effects, or mixing board. Adjust the **AUX VOLUME CONTROL (9)** on the UHF-10 receiver clockwise to about 3/4 full, until the volume level is comfortable for your application. This setting is roughly equivalent to a direct instrument cord connection. Turning the volume up to **MAX** will provide 4dB gain over a cord.

Microphone Connection (using the UB-10 transmitter with either a headworn or lavalier microphone or the UH-10 handheld microphone transmitter)

For microphone use, either the **BALANCED MIC AUDIO OUTPUT XLR (11)** or the 1/4" line level **AUX AUDIO OUTPUT (10)** can be used.

The XLR output is set at a non-adjustable microphone level, similar to hardwired mic levels. Plug an XLR connector into the XLR output socket on the rear of the unit and plug the other end into your amplifier or mixing board. Make sure the phantom power on your mixing board is turned off and the volume is turned down when making connections. For your convenience, the XLR output level is preset at the factory and is not adjustable with the receiver volume control.

To use the 1/4" **AUX AUDIO OUTPUT** socket, follow the instructions for the Instrument Connection (above), except start the receiver volume at 1/2 MAX and adjust until the volume level is optimal. If the volume control is set too high, you may overload your mixer or amp.

The UHF 10 receiver is equipped with an **AF PEAK LED INDICATOR (3)** which lights with a strong audio signal from the transmitter. Occasional flickering on loud inputs to the transmitter is normal. If the LED lights continuously, decrease the volume to the transmitter or overload distortion may result.

UH-10 HANDHELD MICROPHONE

1. Unscrew the **BATTERY COMPARTMENT COVER (13)** and remove, exposing the **BATTERY HOLDER (14)**. Insert a fresh **9V ALKALINE BATTERY (15)**, observing the correct polarity as marked, and screw the cover back on to the microphone. Make sure the cover is screwed on completely. A fresh alkaline battery can last up to 10 hours in use, but in order to ensure optimum performance, it is recommended that you replace the battery after every 7-8 hours of use.
2. Turn on the UH-10 by sliding the **OFF/STANDBY/ON SWITCH (16)** to the **STANDBY** position (transmitter on, audio muted) or the **ON** position (transmitter and audio both on). The **BATTERY INDICATOR LED (17)** will give a single quick flash, indicating usable battery strength. In the case of a dead or low battery, the LED will either not go on at all or will stay on continuously, indicating that the battery should be replaced with a fresh one. To preserve battery life, turn the transmitter off when not in use.

3. The microphone is now ready to use. The A and/or B **DIVERSITY LED INDICATORS (2)** on the UHF 10 receiver should now be lit, indicating a received signal from the transmitter. When ready to speak, slide the transmitter switch to the ON position. Adjust the volume of the receiver as per the Audio Output Microphone Connection section of the above UHF 10 receiver instructions. *[Note: Observe care in selecting P.A. volume, transmitter location and speaker placement so that acoustic feedback (howling or screeching) will be avoided.]*

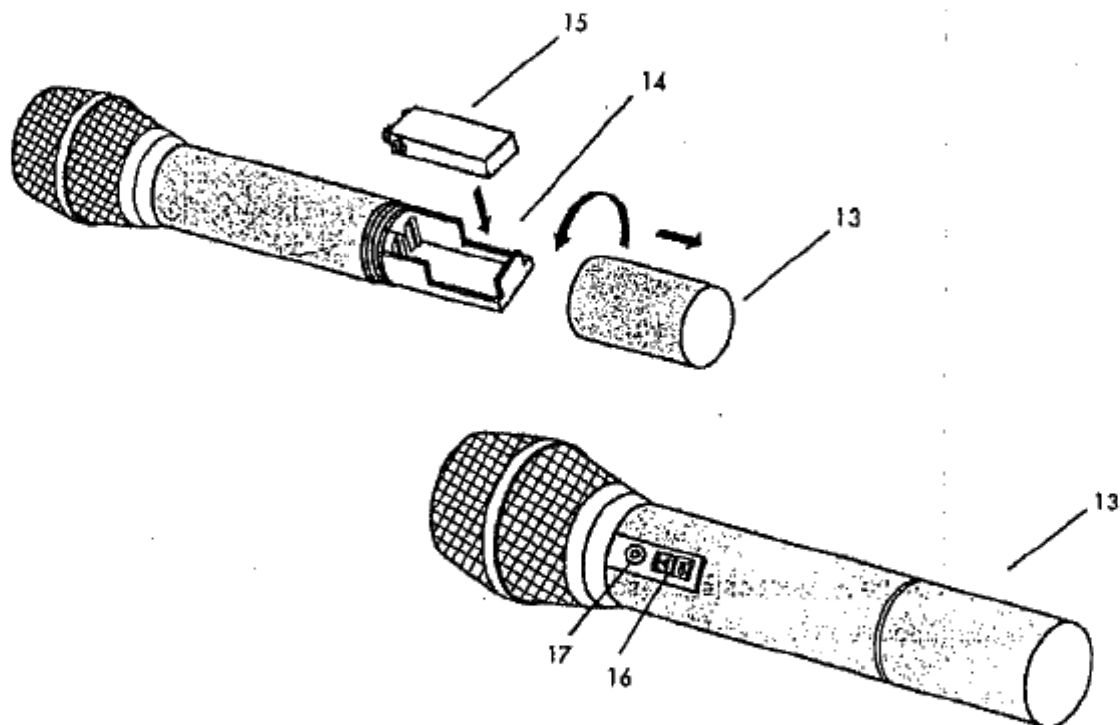

- 13. BATTERY COMPARTMENT COVER
- 14. BATTERY HOLDER
- 15. 9V ALKALINE BATTERY
- 16. OFF/STANDBY/ON SWITCH
- 17. BATTERY INDICATOR LED

UB-10 BODYPACK TRANSMITTER

1. Slide open the hinged **BATTERY COMPARTMENT (18)** and insert a fresh **9V ALKALINE BATTERY (19)**, observing the correct polarity. A fresh alkaline battery can last up to 10 hours in use, but in order to ensure optimum performance, it is recommended that the battery be replaced after 7-8 hours of use.
2. The UB-10 is equipped with an **INPUT SELECTOR SWITCH (20)** in the battery compartment for selecting the type of audio input you will be supplying to the transmitter. Select from the choice of three positions: **INSTRUMENT** (for guitar, bass, etc.)/ **HEADWORN MIC**/ **LAVALIER MIC**.
3. The UB-10 is provided with a **3.5 mm LOCKING JACK (21)** for connecting the audio input selected. Connect either the **INSTRUMENT CORD (22)** or the **HEADWORN MIC (23)** or **LAVALIER MIC CORD (24)** as desired, according to the input selected. (*Note: Use only the input audio source as per the input selected with the AUDIO INPUT SELECTOR SWITCH or the audio will not be optimal—a muddy or distorted sound may result.*) To secure the connection, turn the slip ring on the plug clock wise to thread it on the jack. To unplug, reverse the process. Slip the transmitter into a pocket or **CLIP (28)** it on to your clothes or instrument strap (if using the UB-10 as an instrument transmitter).
4. Turn on the UB-10 by sliding the **OFF/STANDBY/ON SWITCH (25)** to the **STANDBY** position (transmitter on, audio muted) or the **ON** position (transmitter and audio both on). The **BATTERY INDICATOR LED (26)** will give a single quick flash, indicating usable battery strength. In the case of a dead or low battery, the LED either will not go on at all or will stay on continuously, indicating that the battery should be replaced with a fresh one. To preserve battery life, turn the transmitter off when not in use. The transmitter is now ready to use. The **A** and/or **B DIVERSITY LED INDICATORS (2)** on the UHF 10 receiver should now be lit, indicating a received signal from the transmitter.
5. **Instrument Use**
Plug the 1/4" phone plug from the **INSTRUMENT CORD (22)** into the instrument. As the cord to the instrument also serves as the antenna, be sure to extend it fully for maximum range. Rolling up or shortening the cord may reduce the effective operating range. When ready to play, slide the audio **OFF/STANDBY/ON SWITCH (25)** to the **ON** position. Adjust the volume of the receiver as per the Audio Output Instrument Connections section of the above UHF 10 receiver instructions.

For optimum performance, an **INPUT LEVEL CONTROL (27)** is provided on the top panel of the UB-10. Adjust the gain by turning the control with your thumb. For instrument use, it is recommended that this control be turned to maximum gain. However, for ultra high-gain instrument sources such as active bass pickups or even extra hot guitar pickups, turning the level down slightly will create a cleaner sound. *(Note: Turning down the input gain too much can compromise the signal-to-noise ratio and is not recommended. Set for the maximum possible gain and headroom without noticeable distortion on the high level peaks).*

The **AF PEAK LED INDICATOR (3)** on the UHF 10 receiver will light for all loud input signals. Occasional flickering on and off during use is normal, however if the LED stays on continuously, turn down the instrument volume or the **INPUT LEVEL CONTROL (27)** on the UB-10 transmitter, or noticeable distortion may result.

*(Note: Scratchy noises can sometimes occur when some electric guitars with dirty pots or connections are used with any wireless system. Therefore, the supplied **INSTRUMENT CORD (22)** has a factory installed capacitor inside the 1/4" plug. This capacitor provides first order filtering of the RF signal from the cord into the guitar and eliminates virtually all scratchy noises. Should your equipment still give you scratchy noises, we suggest these steps to eliminate them:*

1) Make sure all guitar volume and tone pots are clean and all contacts are solid—this is very important.

2) A 47pf capacitor soldered across the hot to ground terminals of the guitar's volume and tone pots will provide extra filtering.)

6. **Microphone Use (with either a lavalier or headworn microphone)**

Secure the connection from the **LAVALIER (24)** or **HEADWORN MIC CORD (23)** by turning the slip ring on the plug into the transmitter clockwise to thread it on to the jack. To unplug, reverse the process. To use the lavalier mic, attach it at chest level. Do not place it too close to the mouth—a distance of about six inches usually works best. To use the headworn mic, place it on the head and adjust the boom so that the mic is about one inch to the side of the front of the mouth. As the microphone cord also serves as the antenna, be sure to extend it fully. Rolling up or shortening the cord may reduce the effective operating range—keep it as straight as possible.

When ready to speak, slide the **OFF/STANDBY/ON SWITCH (25)** to the ON position. Adjust the volume of the receiver as per the *Audio Output Microphone Connection* section of the above UHF 10 receiver instruc-

tions. [Note: Observe care in selecting P.A. volume, transmitter location and speaker placement so that acoustic feedback (howling and screeching) will be avoided. Please also note the pickup pattern characteristics of the microphone selected. Omnidirectional mics pick up sound equally from all directions, and are prone to feedback if not used carefully. Unidirectional mics are more resistant to feedback, but pick up sound sources best that are directly in front of the mic. Also, mics that are farther from the sound source, such as lavaliers, require more acoustic gain and thus are also more prone to feedback than close-source mics such as handheld or headworn models that are used close to the mouth].

For optimum performance, an **INPUT LEVEL CONTROL (27)** is provided. Adjust the gain by turning the control with your thumb. For lavalier mic use, it is recommended that the level be set at about 2/3 maximum. For headworn mic use, it may be advisable to turn the gain down somewhat, depending on the volume levels expected. In either application, experiment and set for maximum possible gain without audible distortion on the high level peaks. (Note: Turning down the gain too much can compromise the signal-to-noise and is not recommended.)

The **AF PEAK LED INDICATOR (3)** on the UHF 10 receiver will light for all loud input signals. Occasional flickering on and off during use is normal, but if the LED stays lit continuously, turn down the **INPUT LEVEL CONTROL (27)** on the UB-10 transmitter, or noticeable distortion may result.

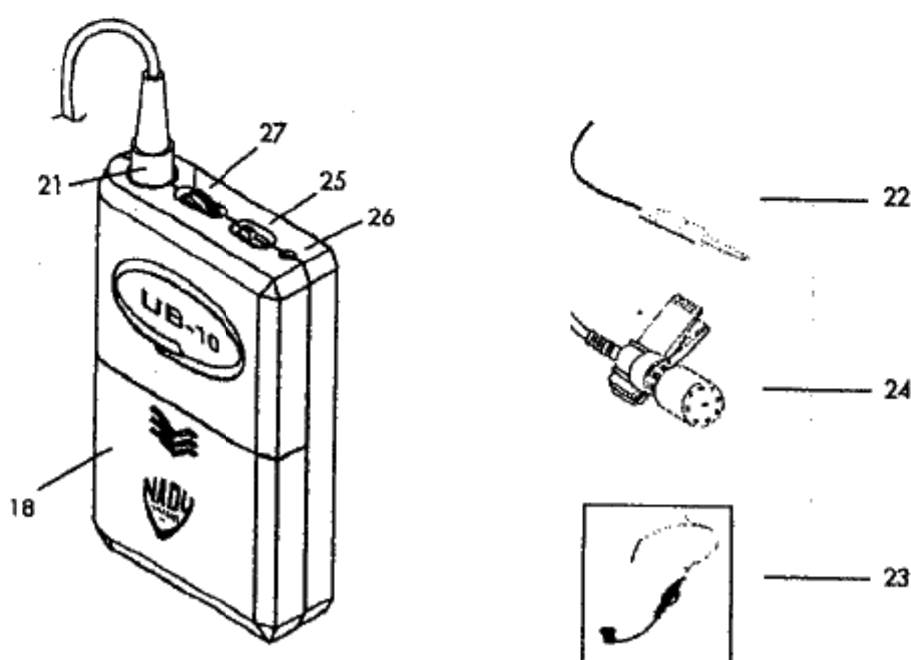

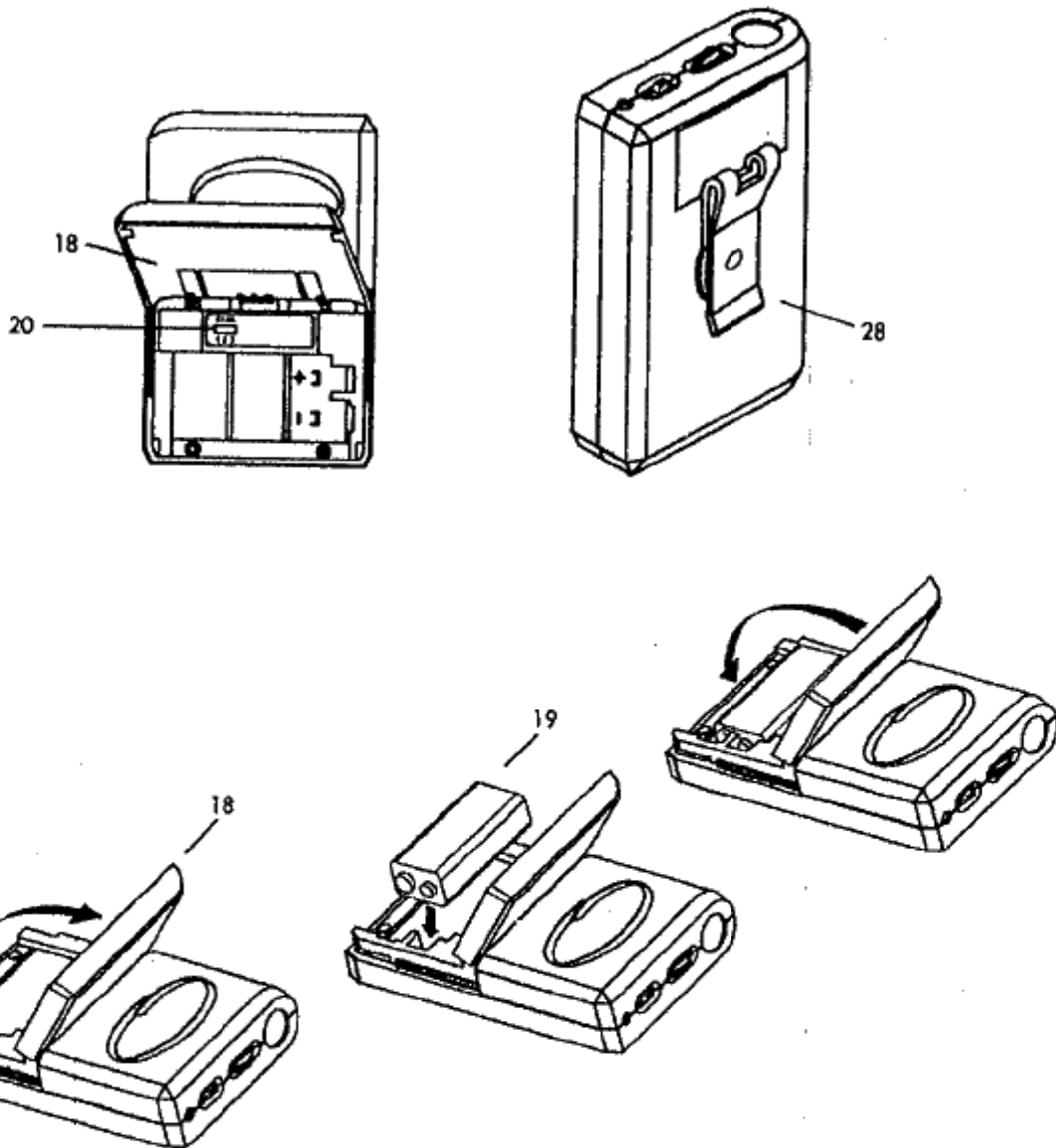

- 18. BATTERY COMPARTMENT
- 19. 9V ALKALINE BATTERY
- 20. INPUT SELECTOR SWITCH
- 21. 3.5mm LOCKING JACK
- 22. INSTRUMENT CORD
- 23. HEADWORN MIC
- 24. LAVALIER MIC
- 25. OFF/STANDBY/ON SWITCH
- 26. BATTERY INDICATOR LED
- 27. INPUT LEVEL CONTROL
- 28. CLIP

SPECIFICATIONS

Frequency Response

50 Hz - 15 KHz, +/- 3 dB

Dynamic Range

120 dB

Total Harmonic Distortion

< 0.6%

RF Carrier Frequency Range

UHF, choice of single frequencies
from 194.9-804.9 MHz

Frequency Stability

+/- 0.005% crystal controlled

Modulation

FM (F3E), +/- 20 KHz

Operating Range

250 feet typical—up to 500+ feet line-of-sight

UHF 10 RECEIVER

Reception Mode

DigiTRU Diversity™ (Dual Antenna)

Squelch

Tone Key (32.768 KHz), External Control

Controls

Power ON/OFF, Volume Control, Squelch (Mute) Adjust

Connectors

DC in, 1/4" (6.3 mm) unbalanced phone jack (750 mV/5K Ohm), XLR balanced output (60 mV/600 Ohm)

LED Indicators

Power ON, Diversity A/B, Audio Peak

Unwanted Signal Rejection

60dB image and spurious

Power Requirements

DC 12-15V @ 300 mA, AC/DC adapter included

Dimensions

16" x 9.4" x 1.73"
(41.0 x 24.0 x 4.4 cm)

Weight

1.15 lb (0.52 Kg)

UHF 10 TRANSMITTERS

Audio Inputs

UB-10 Bodypack: 3.5mm locking mini-jack 3-way select switch for inputs: instrument, headworn mic, or lavalier mic

UH-10 Handheld: Integral Nady DM-10D neodymium dynamic cartridge

Controls

UB-10: OFF/STANDBY/ON, INSTRUMENT/HEADWORN MIC/LAV MIC, INPUT LEVEL

UH-10: OFF/STANDBY/ON

LED Indicator

Unit "ON" (single flash), Low Battery Alert (steady)

RF Power Out

3.34 mW nominal (maximum allowed by FCC)

Harmonic & Spurious Emissions

< -50 dB

Battery

9V Alkaline

Battery Life

8-10 Hours (35mA draw typical)

Dimensions

UB-10: 4.2" x 2.5" x .88"
(10.7 x 6.4 x 2.2 cm)

UH-10: 9.5" x 1.37"
(24.1 x 3.48cm)

Weight

UB-10: 3 oz (84g)

UH-10: 7.5 oz (210g)

Nady wireless systems are type accepted under FCC rules, parts 90, 74 and 15.

This device complies with RSS-210 of Industry & Science Canada. Operation is subject to the following two conditions: (1) this device may not cause harmful interference, and (2) this device must accept any interference received, including interference that may cause undesired operation.

SERVICE

(U.S.) Should your Nady UHF 10 Wireless Microphone System require service, please contact the Nady Service Department via phone at (510) 652-2411 or e-mail to service@nadywireless.com for a Return Authorization (R/A) Number and a service quote (if out of warranty). Make sure the R/A Number is clearly marked on the outside of the package and enclose a cashier's check or money order (if not prepaid with a credit card). Ship the unit prepaid to: Nady Systems, Inc., Service Department, 6701 Shellmound Street, Emeryville, CA 94608. Include a brief description of the problems you are experiencing.

(International) For service, please contact the Nady distributor in your country through the dealer from whom you purchased this product.

The warranty card enclosed with this system contains additional valuable warranty and service information. Keep it in a safe place for future possible reference. Do not attempt to service this unit yourself as it will void the warranty.



NADU SYSTEMS, INC.
6701 Shellmound Street
Emeryville, CA 94608 USA
Tel: 510.652.2411 • Fax: 510.652.5075
E-mail: service@nadywireless.com
www.nadywireless.com