

WT-203P/WT-203PT/WT-205P/WT-205PT

WIRELESS MICROPHONE SYSTEM INSTRUCTION MANUAL

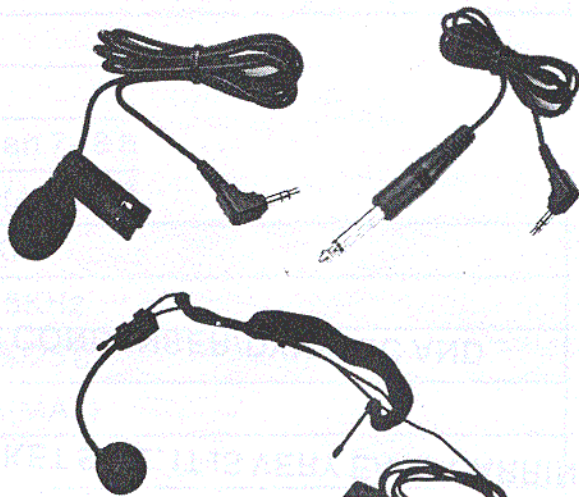
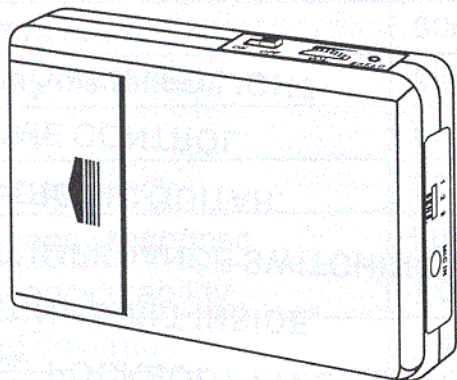

SEKAKU ELECTRON INDUSTRY CO.,
LTD.

FCC ID: H38WT-203F

EXHIBIT #: 8A

FEATURE:

1. SMALL POCKBODY TYPE LIKE A POCKET SIZE. IT IS VERY EASY CARRING.
2. ANTENNA BUILT-INSIDE.
3. INPUT IMPEDANCE SWITCHING (FOR CONDENSER/DYNAMIC AND ELECTRONIC GUITAR.
4. VOLUME CONTROL.
5. LOW POWER LED LIGHT

SEKAKU ELECTRON INDUSTRY CO., LTD.

FCC ID: H38WT-203P

EXHIBIT #: 8B

SEKAKU ELECTRON INDUSTRY CO., LTD.

FCC ID: H38WT-203P

EXHIBIT #: 8C

2.SPECIFICATIONS :

Modulation mode	FM(F3E)
Frequency band	174-216MHz
Receiving mode	Quartz controlled fixed frequency
RF output power	15mW
Current drain	60mA
Battery life (alkali)	More than 7~8 hours
Battery	UM-4*2(AAA SIZE) 3V
Tone frequency	32.768KHz
Frequency response	50Hz~15KHz
Frequency stability	±0.005%/25°C
Rated deviation	±40KHz(MAX)
Spurious emissions	45dBc
Dimensions	.98(L)×19(W)×62(H)mm (2.4L×0.7W×1.41H in)
Net weight	100g (0.18 bs)

OTHER FEATURES:

- 1. SWITCH
- 2. VOLUME CONTROL
- 3. LOW POWER LED LIGHT
- 4. SWITCHING CHANNEL
- 5. MIC. JACK
- 6. LABEL
- 7. SPRING CLIP
- 8. BATTERY COVER

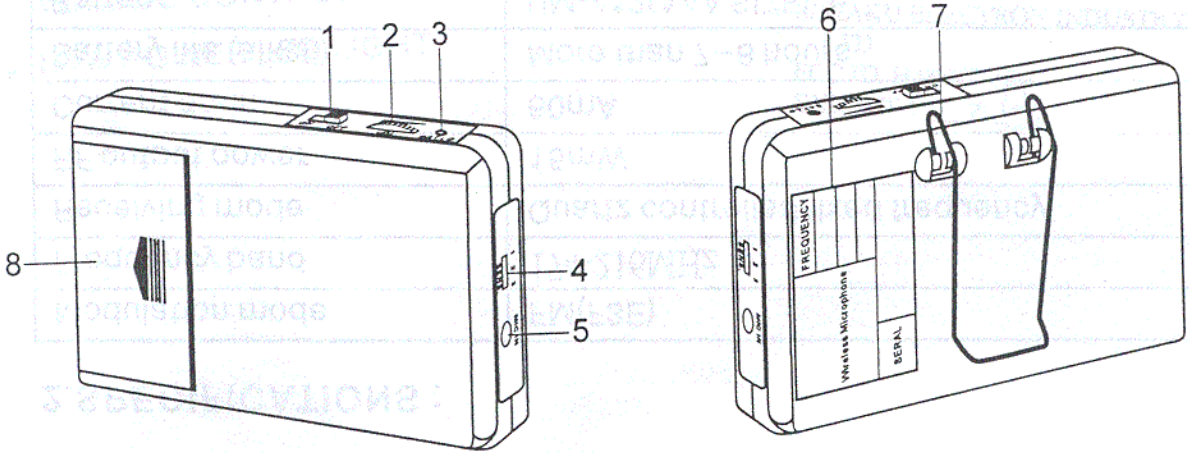

INSTRUCTION

1. AFTER OPERATION THE MICROPHONE MUST BE SWITCHED OFF AS WELL. OTHERWISE THE BATTERIES WILL SOON BE EXHAUSTED. IN ORDER TO AVOID UNUSEFUL CONSUMPTION OF THE INNER BATTERY: IF PILOT LAMP OF THE WIRELESS MICROPHONE (1) REMAINS LIGHTED, IT MEANS THAT THE BATTERY HAS NO MORE POWER: (2) THE LAMP MUST FLASH ONLY FOR THE TIME OF THE SWITCHING -ON; THIS INDICATES THAT THE MICROPHONE WORKS WELL.

2. INSTALL BATTERY: PLS. MAKE SURE THE POSITIVE/NEGATIVE BEFORE YOU REPLACEMENT BATTERIES.

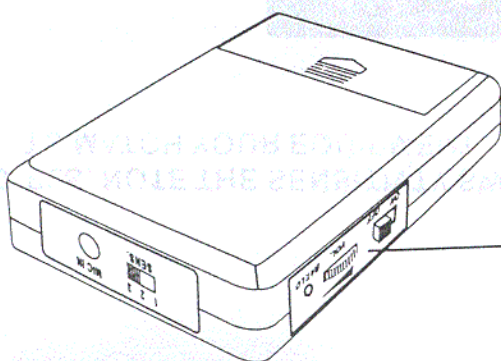
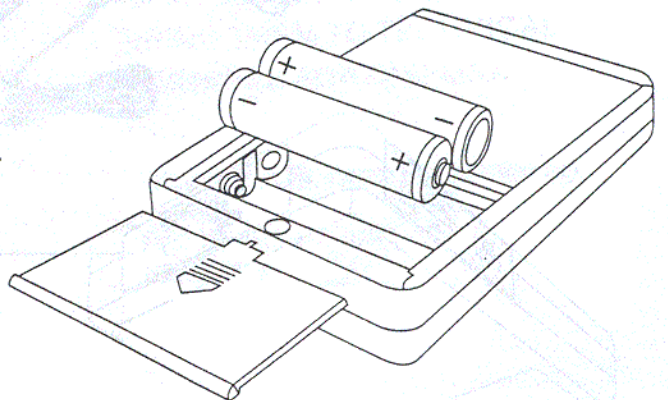

3. PLS. NOTE THE SENSITIVITY SWITCH TO MATCH YOUR EQUIPMENT.

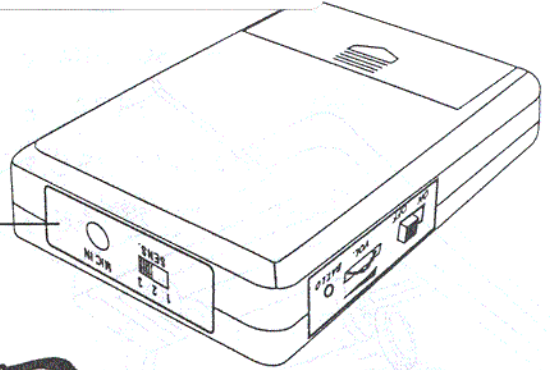

CAUTION:

- SENSITIVITY CHANNEL 1. FOR CONNECTING LM-10L
- SENSITIVITY CHANNEL 2. FOR CONNECTING HM-26L
- SENSITIVITY CHANNEL 3. FOR CONNECTING LS-16L

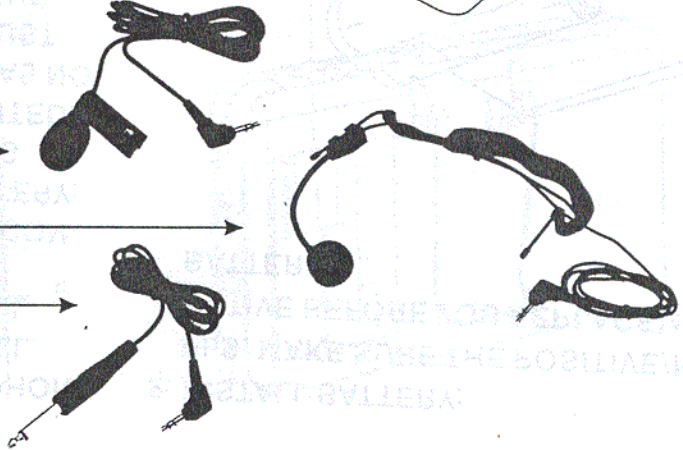

5

5. INTRODUCTION

WE CONGRATULATE YOU FOR THE CHOICE OF THIS EXCELLENT PROFESSIONAL APPARATUS MICROPHONE WHICH WILL GIVE YOU OUTSTANDING RESULTS AT THE HIGH FIDELITY. THE MICROPHONE SUIT FOR SCHOOL SPEECH, MEETING SPEECH, TEACHERS AND PERFORMER ON THE STAGE. TO AVOID OF PROBLEM LIKE WIRE MICROPHONE.

THE BODYPACK MICROPHONE CONNECTION IN EVERY WORKING CONDITION.

6. CAUTION

1. BATTERY USE DC3V(UM-4*2)
2. DO NOT DROP THE MICROPHONE BODY ON THE FLOOR.
3. PROTECT THE UNITS AGAINST HUMIDITY AND HEAT.
4. IF THE UNITS ARE TO BE PUT OUT OF OPERATION DEFINITELY, BRING THEM TO TECHNICAL ENGINEER FOR DISPOSAL.

SEKAKU ELECTRON INDUSTRY CO., LTD.

FCC ID: H38WT-203P7

EXHIBIT #: 8F