

USER MANUAL

Version 2.0.2 (2006.05.22)

**Parani SD™
100**

Bluetooth RS232C Serial Adaptor

by Bluetooth
Enabling Wireless Serial Communications

FCC CONCERNS

FCC Compliance Statement

This device complies with part 15 of the FCC Rules. Operation is subject to the following two conditions:

- (1) This device may not cause harmful interference, and
- (2) This device must accept any interference received, including interference that may cause undesired operation.

This equipment has been tested and found to comply with the limits for a Class B digital device, pursuant to part 15 of the FCC Rules. These limits are designed to provide reasonable protection against harmful interference in a residential installation.

This equipment generates, uses and can radiate radio frequency energy and, if not installed and used in accordance with the instructions, may cause harmful interference to radio communications. However, there is no guarantee that interference will not occur in a particular installation. If this equipment does cause harmful interference to radio or television reception, which can be determined by turning the equipment off and on, the user is encouraged to try to correct the interference by one or more of the following measures:

- Reorient or relocate the receiving antenna.
- Increase the separation between the equipment and receiver.
- Connect the equipment into an outlet on a circuit different from that to which the receiver is connected.
- Consult the dealer or an experienced radio/TV technician for help.

RF Exposure Statement:

The equipment complies with FCC RF radiation exposure limits set forth for an uncontrolled environment. This device and its antenna must not be co-located or operating in conjunction with any other antenna or transmitter.

Do not

Any changes or modifications to the equipment not expressly approved by the party responsible for compliance could void user's authority to operate the equipment.



● Parani-SD100

Bluetooth Serial Adaptor	SD100 
Part Number	
Description	External type wireless serial adapter with dip switch
Power Class	Class1
RF Range	Up to 100m
Power Connector	DC plug or 9 pin
Power supply	DC5V / 2A (AC100-240V / 50Hz-60Hz)
Serial connector	Female DB9
Serial Interface	RS-232
Dip switch	Yes (4 slots)
Profile	Serial Port Profile
Applicable Antenna	Stub Antenna, Dipole Antenna, Patch Antenna
Dimensions (H×W×D)	62.5x31.2x16.3
Includes	Helical Antenna, DC power cable

Table of Contents

1. Getting Started

Components	-----	4
Assembly	-----	4
Locating the Controls	-----	5

2. Configurations

Operation Modes	-----	7
LED Indicators	-----	8
Serial Ports	-----	8
Reset to Factory Defaults	-----	8
Terminal Program	-----	9
Dip Switch	-----	10
Pairing Button	-----	10

3. Connections

RS232 Interface	-----	13
Pin Assignment	-----	14
Power Supply	-----	15

4. Specifications

Bluetooth	-----	17
Serial Interface	-----	17
Power	-----	17
Mechanical Dimensions	-----	17
Environmental	-----	17
Default Antenna	-----	18
Wireless Coverage	-----	18

Appendix A. AT Commands

Terminology	-----	A-2
Command Description	-----	A-3

1. Getting Started

- Components
 - Assembly
- Locating the Controls

Components

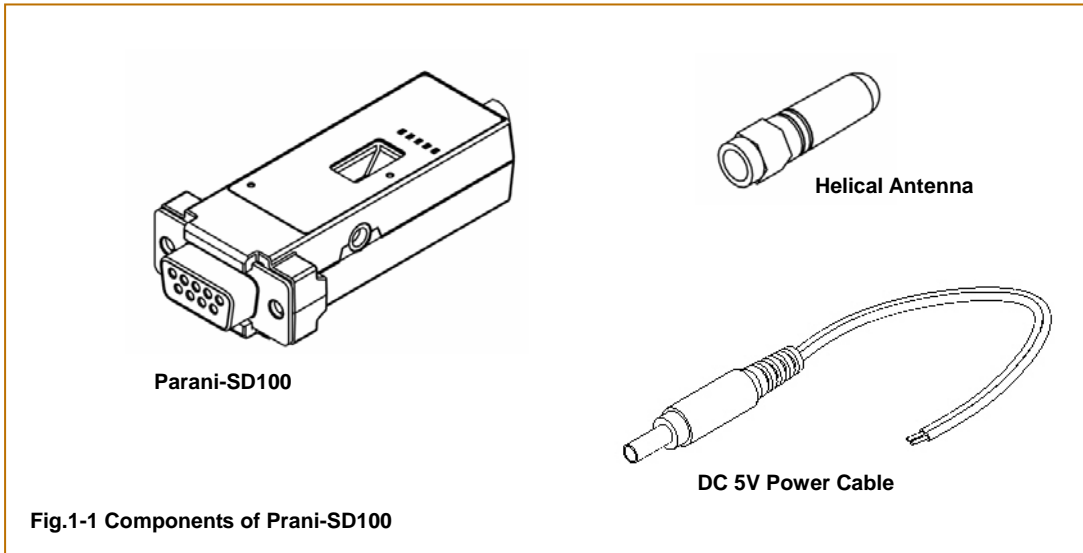

Assembly

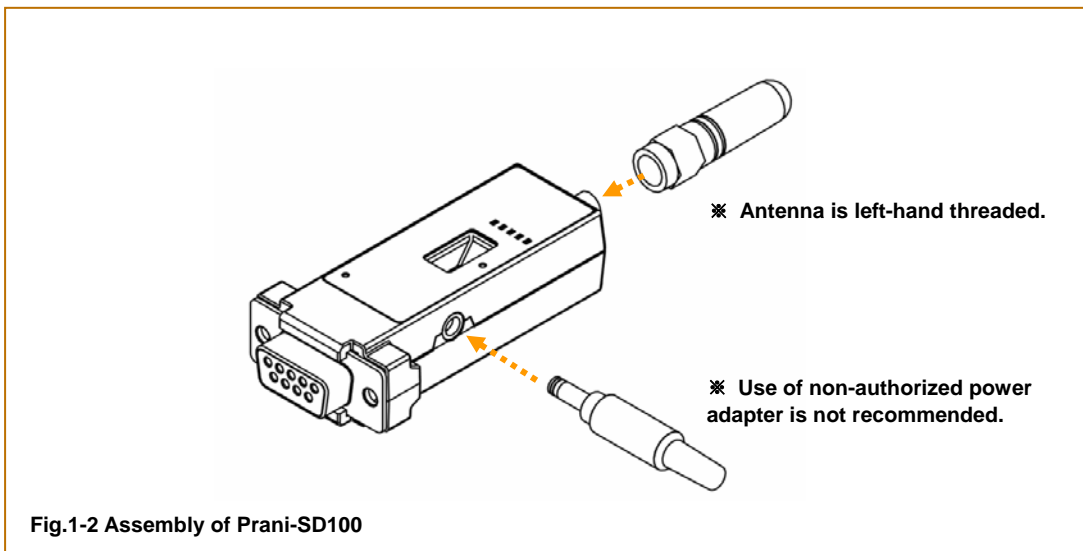

Locating the Controls

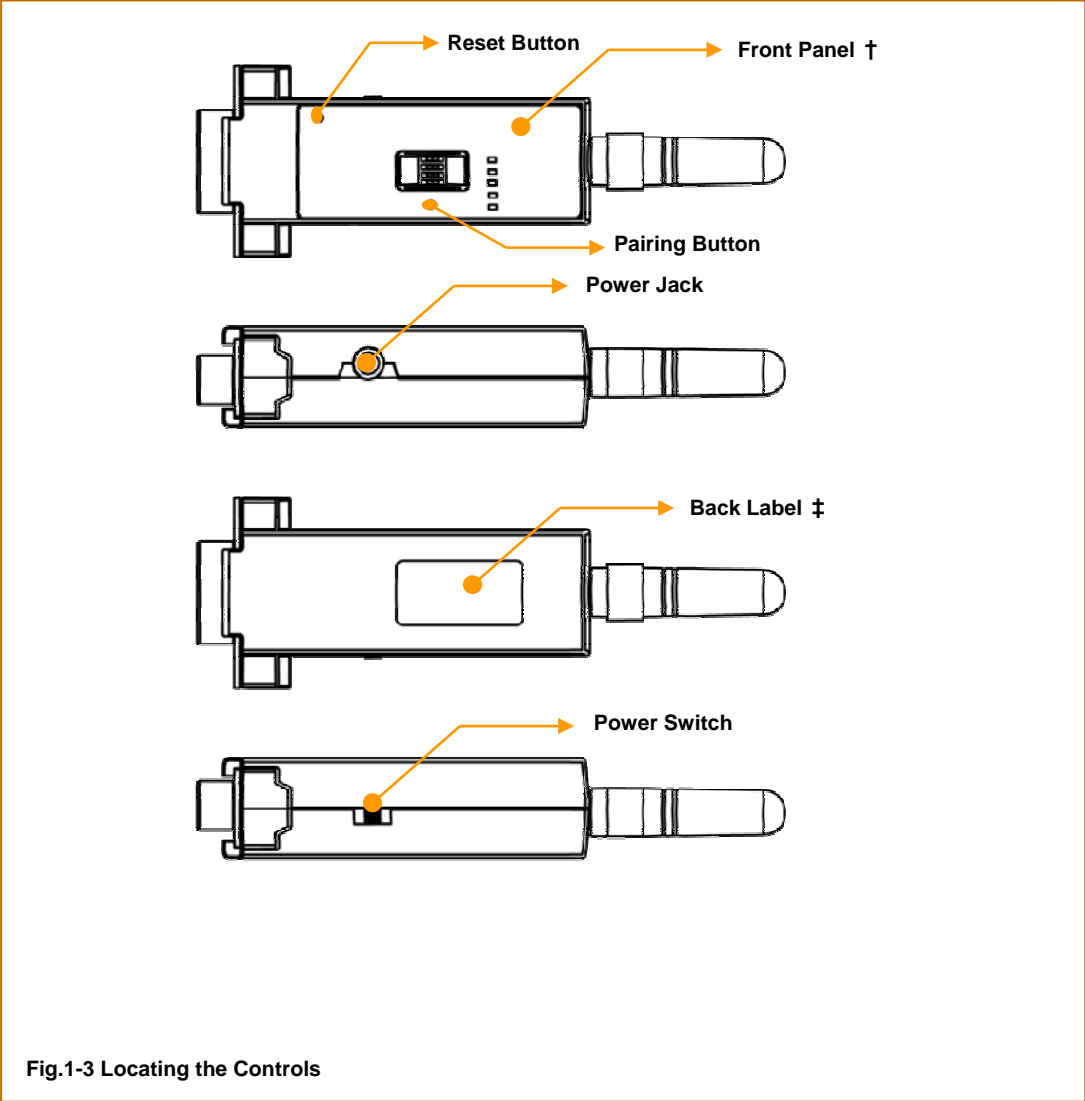

Fig.1-3 Locating the Controls

2. Configurations

- Operation Modes
 - LED Indicators
 - Serial Ports
- Reset to Factory Defaults
 - Terminal Program
 - Dip Switch
 - Pairing Button

Operation Modes

In addition to the serial port configurations such as bit/second, data bit, parity, stop bit, flow control, Parani-SD has some configurations for Bluetooth. For getting the most out of Parani-SD100, user should understand the following Bluetooth connection schemes.

A Bluetooth device can play a role as a master or slave. Master tries to connect itself to other Bluetooth device, and slave is waiting to be connected from other Bluetooth devices. A Bluetooth connection is always made by a pair of master and slave. A slave can be in two modes, Inquiry Scan or Page Scan mode. Inquiry Scan mode is waiting the packet of inquiry from other Bluetooth devices and Page Scan mode is waiting the packet of connection from other Bluetooth devices. Every Bluetooth device has its unique address, called BD (Bluetooth Device) address, which is composed of 12 hexa-decimal numbers.

Parani-SD100 has 4 operation modes as follows. Each mode can be identified with LED indicators as illustrated in next section.

↳ Mode0

Parani-SD100 must be in Mode0, when it is directly controlled by AT commands.

In this mode, there is no response when power on or software reset, and Parani-SD100 is just waiting for AT command input. Neither master nor slave is assigned to Parani-SD100 in mode0. User can change the configurations of Parani-SD100 in this mode.

The factory default is set to Mode0.

↳ Mode1

Parani-SD100 tries to connect the last connected Bluetooth device.

Parani-SD100 in Mode1 is to be a master and tries to connect the last connected Bluetooth device. Parani-SD100 always stores the BD address of the Bluetooth device to which Parani-SD100 has connected last time. When Parani-SD100 is initially used or after hardware reset, there is no BD address stored in Parani-SD100. In this case, Mode1 does not make any sense and mode change from other operation modes to Mode1 is not allowed. The mode change to Mode1 can be made after Parani-SD100 succeeds to connect to other Bluetooth device in Mode0. Once changed to Mode1, Parani-SD100 will try to connect automatically the last connected Bluetooth device whenever power on or software reset.

Parani-SD100 in Mode1 cannot be discovered or connected by other Bluetooth devices.

↳ Mode2

Parani-SD100 is waiting for the connection from the last connected Bluetooth device.

Parani-SD100 in Mode2 is to be a slave and waiting for the connection only from the last connected Bluetooth device. Just like Mode1, if there is no BD address stored in Parani-SD100, the mode change from other operation modes to Mode2 is not allowed. Once changed to Mode2, Parani-SD100 will wait for the connection from the last connected Bluetooth device whenever power on or software reset.

Parani-SD100 in Mode2 cannot be discovered or connected to Bluetooth devices other than the last connected device.











↳ Mode3

Parani-SD100 is waiting for the connection from any other Bluetooth devices.

Parani-SD100 in Mode3 acts like in Mode2, but allows any connection from other Bluetooth device. Most of general Bluetooth device is set to Mode3.

Parani-SD100 in Mode3 can be discovered and connected from any other Bluetooth devices.

LED Indicators

Indicator	Power LED	Standby LED	Connect LED
Mode0	Green 	Red 	
Mode1	Green 		Green (every 1 sec) 
Mode2	Green 		Green (every 3 sec) 
Mode3	Green 		Green (every 3 sec) 
Connected	Green 		Green 

RS232-Tx and RS232-Rx LED are blinking accordingly when data is transmitted. For small data transmission, it may be hard to recognize the quick blinking.

Serial Ports

The applicable settings for serial ports are as follows.

Serial Port Settings	Values
Baud rate	1200, 2400, 4800, 9600 , 19200, 38400, 57600, 115200, 230400
Data bit	8
Parity	No parity , Even parity, Odd parity
Stop bit	1 , 2
Hardware Flow Control	Use , No use

The values in box are the factory defaults.

↘ Data Bit

Parani-SD100 supports only 8 data bit. In the case of 7 data bit, please contact the technical support.

↘ Hardware Flow Control

Parani-SD100 plugged into its host system transmits data from host to the other side Bluetooth device. These data is saved temporarily in the internal buffer of Parani-SD100 and sent repeatedly until the transmission is completed packet by packet. When the radio transmission condition is not good enough to send data promptly, it can cause the transmission delay. If the host sends more data when the buffer is full, buffer overflow will make Parani-SD100 malfunction consequently. In order to prevent this buffer overflow, Parani-SD100 works as follows.

In case of using hardware flow control, Parani-SD100 makes RTS be 'disable' to stop receiving further data from the host when the buffer becomes full. RTS will be 'able' to begin receiving data again from the host when the buffer has some room for more data.

In case of not using hardware flow control, Parani-SD100 clears the buffer to secure the room for next data when the buffer becomes full. This means the loss of data. As the transmission data becomes large, the possibility of data loss goes higher.

For large data transmission, use of hardware flow control is highly recommended.

Reset to Factory Defaults

To turn back all the configurations to its factory settings, press the reset button depicted in Fig. 1-3. Press the reset button with a narrow pointed tool like paper clip longer than 1 second. Reset works only when power is on.

Terminal Program

A terminal program is an application that will enable a PC to communicate directly with a modem. If you are using Windows 98SE or higher version of Windows, HyperTerminal program as it is included as part of the operating system. Parani-SD100 provides some extended AT commands for its configurations on terminal program.

This manual will explain the method using HyperTerminal. If you need to install HyperTerminal, click start>setting>control panel>add/remove programs. For more precise information, please refer to Help of Microsoft Windows.

Attach Parani-SD100 to serial port of host computer and power on. Standby LED is lit in green.

Launch HyperTerminal. It can be found in start >programs >accessories >communication >HyperTerminal. Select the Serial port that Parani-SD100 will be connected to.

Input the same settings into Serial port configuration window as Parani-SD100 settings.

The settings need to be set correctly, otherwise, error message may be shown up on the screen or cause malfunctioning of Parani-SD100.

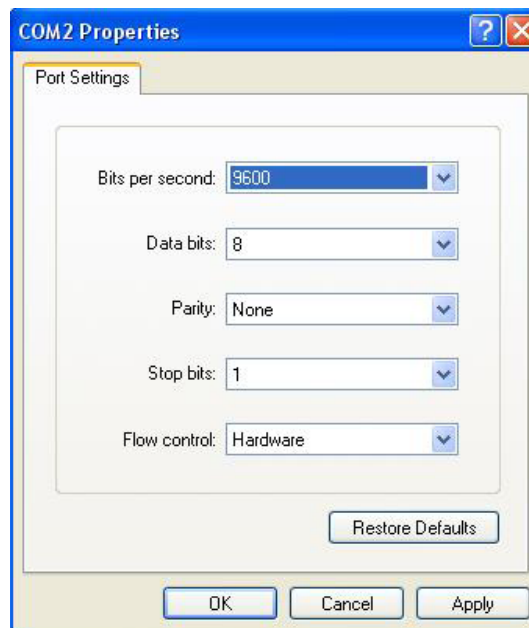

Choose the settings in File->Properties->Settings->ASCII setup that let you turn echo on in HyperTerminal; this will show the response Parani-SD100 sends on the screen.

You now get the HyperTerminal window where you are able to control Parani-SD100 with AT commands. For expanded AT commands that Parani-SD100 provides, please refer to Appendix A. AT commands.

Example of AT commands:

```

AT+BTINFO?
000195000509,PSDv3b-000509,MODE0,STANDBY,0,0,HWFC

OK
AT+BTINQ?
00019520007E,PSDv2a-20007E,001F00

0004B300E205,AP2002:1 #0,020300

OK
ATD00019520007E
OK

CONNECT 0001952007E
    
```

Dip Switch

With the combination of 4 slot dip switches, baud rate and hardware flow control can be set simply without host computer.

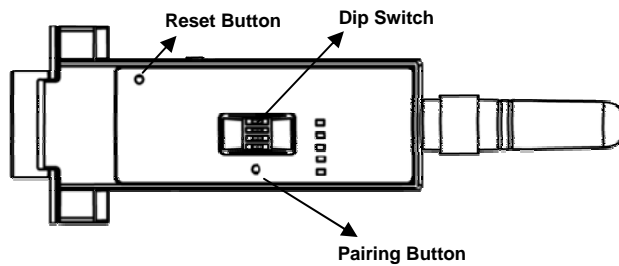

Upper 3 dip switches are used for setting baud rate, and bottom dip switch is used for setting hardware flow control option. If the baud rate needs to be set out of the range given below, PromiWIN or terminal program should be used for extended AT commands. At this time combination of dip switches must be complied with AT cmd. Then baud rate will go back to 9600 as default.

Baud Rate	2400	4800	9600	19.2K	38.4K	57.6K	115.2K	AT cmd
Hardware Flow Control Handshaking	No use		Use					

Pairing Button

Parani-SD100 provides Pairing Button for instant configuration without PC to make an automatic connection between two Parani-SD100s. For convenience sake, name two Parani-SD100s as SD1 and SD2 respectively.

1. Turn off all the nearby Parani-SD100
2. Turn on SD1 and SD2 and hardware reset both of them by pressing Reset Button.
3. Press the Pairing Button of SD1 for 2 seconds until Standby LED turns off and Connect LED blinks 3 times every 2 seconds. Keep the power ON.

4. Press the Pairing Button of SD2 for 2 seconds until Standby LED turns off and Connect LED blinks 3 times every 2 seconds. Now press again the Pairing Button for 2 seconds until Connect LED blinks every 0.5 second.
5. Wait for SD1 & SD2 to be connected for a while until Connect LED's of SD1 and SD2 is lit in green. It takes about 10 seconds to make a connection. If there are many Bluetooth devices nearby, it will take a little bit more.
6. Turn SD1 off and on. Connect LED blinks twice in green every 3 seconds.
7. Turn SD2 off and on. Connect LED blinks once in green every 1 second.
8. Now a pair of Parani-SD100 is configured to make automatic connection, whenever power off and on.
9. Just use this pair of Parani-SD100 like virtual serial cable.

SD 1	status	LED	SD 2	status	LED
1. hard reset	Mode0	Standby LED turn on.	1. hard reset	Mode0	Standby LED turn on.
2. push pairing button	Mode3	Connect LED blinks 3 times every 2 sec.	2. push pairing button	Mode3	Connect LED blinks 3 times every 2 sec.
3.			3. push pairing button again	Mode1	Connect LED blinks every 0.5 sec.
4. connected	Slave	Connect LED is lit in green	4. connected	Master	Connect LED is lit in green

3. Connections

- **RS232 Interface**
- **Pin Assignment**
- **Power Supply**

RS232C Interface

↳ DTE/DCE

If the full EIA232 standard is implemented as defined, the equipment at the far end of the connection is named the DTE device (Data Terminal Equipment, usually a computer or terminal), has a male DB9 connector. Equipment at the near end of the connection (the telephone line interface) is named the DCE device (Data Circuit-terminating Equipment, usually a modem), has a female DB9 connector. The cable linking DTE and DCE devices is a parallel straight-through cable with no cross-overs or self-connects in the connector hoods. If all devices exactly followed this standard, all cables would be identical, and there would be no chance that an incorrectly wired cable could be used.

↳ DB9 Female

Parani-SD100 is a DCE device compatible with RS232 standard, having DB9 female interface.

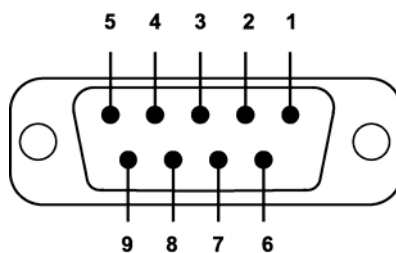

Pin #	Signal	Direction	Description
1	CD	Output	Bluetooth Connect Status
2	TxD	Output	Transmitted Data
3	RxD	Input	Received Data
4	DSR	Input	DTE Ready
5	GND	-	Signal Ground
6	DTR	Output	DCE Ready
7	CTS	Input	Clear to Send
8	RTS	Output	Request to Send
9	Vcc	Input	5V ~ 12v

Pin Assignment

↳ To Host with DTE Interface

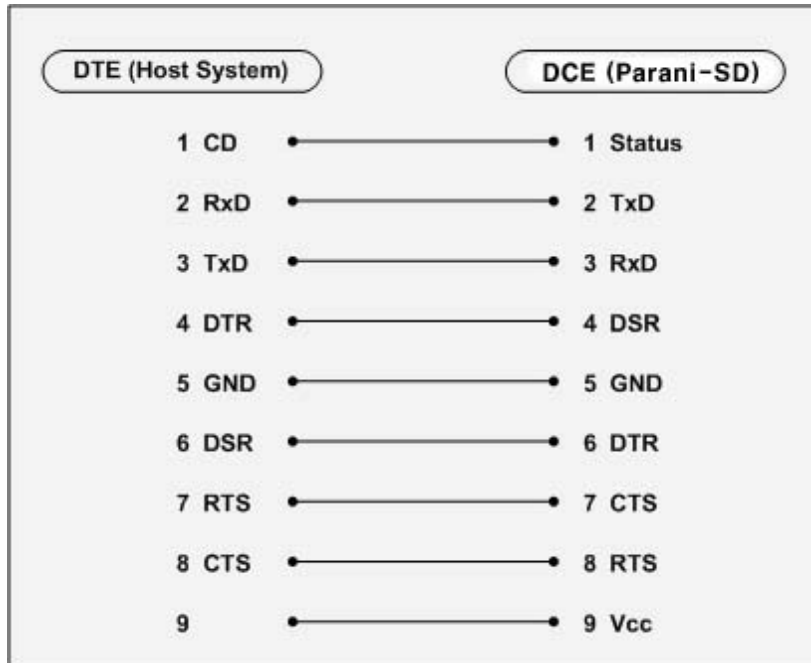

↳ To Host with DCE Interface

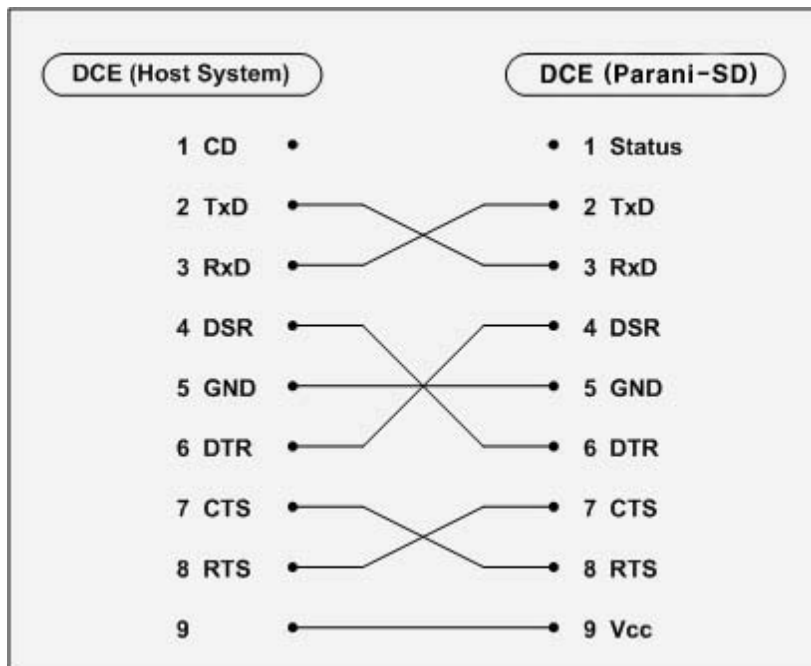

Power Supply

Parani-SD100 can be supplied power through the power jack and through pin 9 of DB9 connector.

↳ Through Power Jack

DC 5 V, Min. 150mA power should be supplied through DC power cable. Red cable is positive and black one is negative.

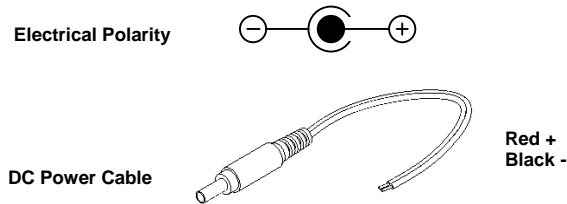

AC/DC power adaptor and USB power cable are also available to supply power.



↳ Through Pin 9 of DB9 connector

The power can be supplied through pin 9 of DB9 connector. Because Parani-SD100 does not have any protection circuit from surge, it must be constant voltage of 5 ~ 12V.

4. Specifications

- Bluetooth
- Serial Interface
- Power
- Mechanical Dimensions
 - Environmental
 - Default Antenna
 - Wireless Coverage

Bluetooth Interface

- Bluetooth 1.2 specification compatible and qualified
- Protocol: RFCOMM, L2CAP, SDP
- Profiles: Serial Port Profile, Generic Access Profile, Service Discovery Profile
- Radio Frequency: 2.402 – 2.480GHz
- Number of Channels: 79
- Transmission Power Class 1
- Data Transmission Rate: 380Kbps Max.

Serial Interface

- EIA RS232C Standard
- Connector: DB9 female
- Data Transmission Rate: 1,200 ~ 230,400bps
- Hardware Flow Control: On/Off

Power

- DC 5 V Constant Voltage
- Supply: DC Jack or Pin 9 of DB9

Mechanical Dimensions

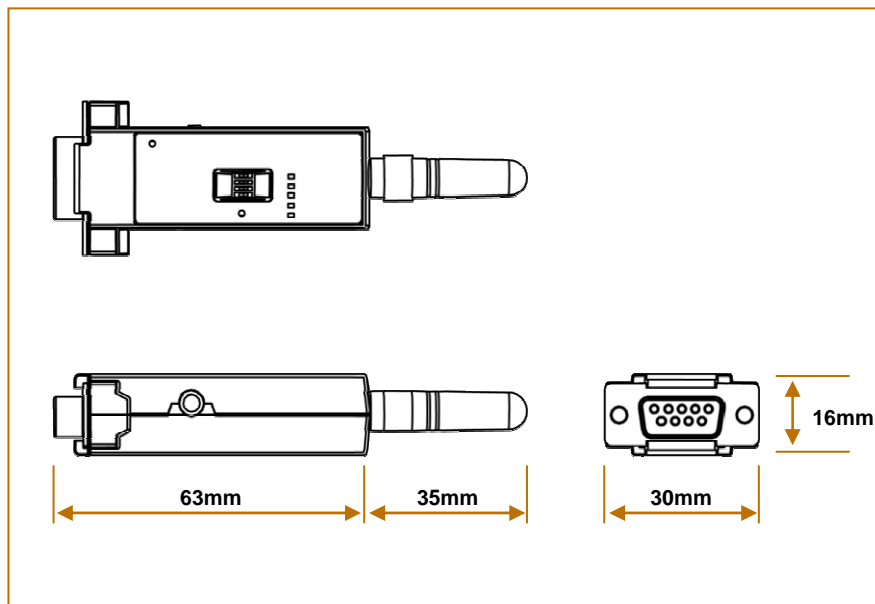

Environmental

- Recommended Operational Temperature: -20°C ~ 70°C
- Recommended Operational Humidity: 90% Max. Non-condensing

↘ Default Antenna

- Type: Helical
- Frequency: 2,400 ~ 2,485GHz
- Gain: Max. 2dBi
- Impedance: 50Ω
- size: 30mm×9mm (W×D)
- weight: 3.5g

↘ Wireless Coverage

The table below shows the average measuring results in open space. These results can vary according to the environmental conditions.

Antennas for two Parani-SD100 units	Maximum Distance
Helical Antenna	100m

Appendix A. AT Commands

- Terminology
- Command Description

Terminology

↘ AT Command

AT command set is the de facto standard language for controlling modems. The AT command set was developed by Hayes and is recognized by virtually all personal computer modems. Parani-SD100 provides the extended AT command set to control and configure the serial parameters and Bluetooth connection.

↘ AT Response

Parani-SD100 replies to AT commands with 4 kinds of message, 'OK', 'ERROR', 'CONNECT' and 'DISCONNECT'.

↘ Operation Mode

- Mode0: Waiting for AT commands
- Mode1: Attempting to connect to the last connected Bluetooth device
- Mode2: Waiting for the connection from the last connected Bluetooth device
- Mode3: Waiting for the connection from any other Bluetooth devices

↘ Operation Status

- Standby: Waiting for AT commands
- Pending: Executing tasks
- Connect: Transmitting data

↘ Security

- Authentication: Pin code (or Pass key)
- Encryption: Data encryption

↘ Symbols

The symbols are used for the description of command syntax as follows:

Symbol	Meaning	ASCII Code
↵	Carriage return	0x0D
↵	Line feed	0x0A
↵↵	Carriage return + Line feed	
112233445566	Bluetooth device address	
n or m	One digit decimal number	
to	Timeout in second	

Command Description

1 ATZ↵

SD Response	↵OK↵
Purpose	Software Reset
Description	This is the same effect as power off and on. This command disconnects Bluetooth device, and stops ongoing task. After rebooting, the status is decided by the preset operation mode. Some AT commands need ATZ to take effect.

2 AT&F↵

SD Response	↵OK↵
Purpose	Hardware reset
Description	This is the same effect as initialization by reset button. All parameters are initialized to factory defaults. The storage of Parani-SD100 is cleared completely.

3 AT↵

SD Response	↵OK↵
Purpose	Check the connection status with host equipment
Description	Check if the connection to host equipment is normal. The serial parameters of Parani-SD100 must be same as those of host equipment. If not, SD response is none or 'ERROR' or abnormal sequence of strings.

4 AT+UARTCONFIG,Baudrate,Parity,Stopbit

SD Response	↵OK↵
Purpose	Set Serial parameters
Parameters	<i>Baudrate</i> =1200/2400/9600/14400/19200/38400/57600/115200/230400 (Default=9600) <i>Parity</i> =N/E/O (Default=N) <i>Stopbit</i> =1/2 (Default=1)
Description	The Serial parameters can be set or changed. The factory default is 9600, N, 1. To take effect of this command, ATZ or power off and on.
Example	AT+UARTCONFIG,9600,N,1

5 AT+USEDIP?

SD Response	↵m↵
Purpose	Check the Baud rate set by dip switch
Description	<i>m</i> =0: Set to 'AT cmd' <i>m</i> =1: Set to other than 'AT cmd'

6 AT+BTINFO? ↵

SD Response	↵112233445566,DeviceName,Mode,Status,Auth,Encryp,FlowControl↵ ↵OK↵
Purpose	Display Bluetooth settings
Description	The current Bluetooth settings are displayed including BD address, Device name, Operation mode, Operation status, Authentication, Data Encryption, and Hardware Flow Control. The initial value of Device name is 'PSDv3b-445566'. PSD stands for Parani-SD100, v3b for the version of firmware, and 445566 for the last 6 digits of BD address. Mode=MODE0/MODE1/MODE2/MODE3 Status=STANDBY/PENDING/CONNECT Auth=0/1 (Authentication is not activated when 0) Encrypt=0/1 (Encryption is not activated when 0) FlowControl=HWFC/NoFC
Example	↵00B530011FF,SENA,MODE0,PENDING,1,1,HWFC↵

7 AT+BTINQ? ↵

SD Response	↵112233445566,FriendlyName,CoD↵ ↵112233445566,FriendlyName,CoD↵ ↵112233445566,FriendlyName,CoD↵ ↵OK↵
Purpose	Search Bluetooth devices nearby
Description	The Bluetooth devices in Inquiry scan mode nearby are displayed with their BD addresses, Device names, and Class of device. Maximum 10 devices are scanned for 30 seconds.

8 AT+BTLAST? ↵

SD Response	↵112233445566↵ ↵OK↵
Purpose	Display the BD address of the last connected device
Description	The Bluetooth device connected to this Parani-SD100 last time is displayed with its BD address.

9 AT+BTMODE,*n* ↵

SD Response	↵OK↵
Purpose	Set operation mode
Parameters	<i>n</i> =0: MODE0 (Default) <i>n</i> =1: MODE1 <i>n</i> =2: MODE2 <i>n</i> =3: MODE3
Description	When the operation status is 'Pending' currently, change the status to 'Standby' with AT+BTCANCEL prior to this command. To take effect of this command, ATZ or power off and on.
Example	AT+BTMODE,2 ↵OK↵ ATZ

10 +++

SD Response	↵OK↵
Purpose	Convert the operation status of 'Connect' to 'Standby'
Description	<p>In 'Connect' status, data from host is transmitted to the other side Bluetooth device, and any AT command is not accepted but this command, which is not echoed on the screen.</p> <p>When Parani-SD100 encounters a character '+' from host, it stops the data transmission and waits for next 2 characters. If the next 2 characters aren't both '+', it restart to transmit data including the first '+' as well. If not, it converts the operation status to 'Standby'.</p> <p>If the data from host includes '+++', it will convert the operation status to 'Standby' unexpectedly. Notice that Parani-SD100 holds data transmission when it encounters '+', until receiving next character.</p> <p>'+' is an escape sequence character by default, which is changeable by AT+SETESC.</p>

11 ATO↵

SD Response	None
Purpose	Convert the operation status of 'Standby' to 'Connect'
Description	You can convert the operation status of 'Standby' to 'Connect' ready to transmit data.

12 AT+BTCANCEL↵

SD Response	↵OK↵
Purpose	Terminate a current executing task
Description	This terminates a current executing task, such as Inquiry scan and Page scan, then converts the operation status to 'Standby'.
Reference	ATD, AT+BTINQ?, AT+BTCANCEL
Example	AT+BTSCAN,2,30
Reference	ATD, AT+BTINQ?, AT+BTCANCEL
Example	AT+BTSCAN000B530011FF,30

13 ATD↵

SD Response	↵OK↵ ↵CONNECT 112233445566↵ or ↵OK↵ ↵ERROR↵
Purpose	Connect to the last connected Bluetooth device
Description	Parani-SD100 saves the BD address of the Bluetooth device most recently connected. ATD can make connection to it without input its BD address. If it fails to make connection, SD response is 'ERROR'.

14 ATD112233445566↵

SD Response	↵OK↵
-------------	------

	CONNECT 112233445566 or OK ERROR
Purpose	Connect to the Bluetooth device with given BD address
Parameters	112233445566=BD address
Description	Parani-SD100 attempts to connect to the Bluetooth device with the given BD address. To make successful connection, the Bluetooth device must be in Page scan. This attempt continues for 5 minutes. If it fails to make connection, SD response is 'ERROR'.
Example	ATD000B530011FF

15 ATH

SD Response	OK DISCONNECT
Purpose	Release the current connection
Description	The current Bluetooth connection is released normally. It takes about 30 seconds to detect an abnormal disconnection such as power off and moving out of service range.

16 AT+BTLPM,*n*

SD Response	OK
Purpose	Set low power mode
Parameters	<i>n</i> =0: Inactivate (Default) <i>n</i> =1: Activate
Description	During no data transmission, Promi-SD can be in low power mode to save the power consumption. It takes a few seconds to wake up Promi-SD in low power mode.

17 AT&V

SD Response	S0:m0;S1:m1; ...Sn:mn OK
Purpose	Display all the S-register
Description	All parameters are stored at S-register in flash memory. These values are sustained until hardware reset.

18 ATSn?*n*

SD Response	value OK
Purpose	Display a given S-register
Parameters	<i>nn</i> = Address of S-register
Description	A specific S-register is displayed.

19 ATSn=*mm*

SD Response	↵OK↵
Purpose	Change S-register value
Parameters	nn= Address of S-register mm= New value of S-register
Description	Some S-registers are optimized for the overall performance and protected from an arbitrary change by user. When users try to change these S-registers, SD response is 'ERROR'. For details of S-register, refer Appendix. B.
Example	ATS10=0