

Product Specification imago G1 2.7

Author: Philipp Maurer

Description: Product Specification imago G1 2.7

Document: imagotag_product-specification_g1-2.7_en.docx

Version: 1.4

Status: released

Last change: 30.10.2014

Content

1	Description	3
1.1	Key Features	3
2	Mechanical Characteristics	4
2.1	Technical characteristics.....	4
2.2	Mechanical Dimensions.....	5
2.3	Barcode Information.....	5
2.4	Serial Number	6
3	Electrical & RF Characteristics	7
3.1	Power and Current Consumption	7
3.2	Transmission power.....	7
4	E Ink Display	8
4.1	Overview	8
5	Environmental	9
5.1	Operating Conditions.....	9
5.2	Cleaning Instructions	9
5.3	Storage Conditions.....	9
5.4	Humidity Conditions	9
6	Battery Replacement	10
6.1	Audience	10
6.2	Instructions	10
6.3	Steps	10
7	Reliability Test Items	11
8	Packing	12
8.1	Packing Dimensions	12
8.2	Ordering Information.....	12
9	Certifications	13
9.1	Applied Standards.....	13
9.2	Declaration.....	13
10	Security Terms	14

1 Description

The G1 2.7 is a part of the imago G1 electronic shelf label family with 2.7 inch, 4.4 inch and 7.4 inch e-Ink displays.

The main features of this product are:

- 264 x 176 px
- 57 x 38 mm active display area
- Up to 5000 label updates per hour
- 5-year battery lifetime with 4 updates per day

This document is the technical specification of the G1 2.7 inch label

1.1 Key Features

- 2.4 GHz bi-directional MSK proprietary radio
- Radio coverage: up to 25 meters
- Return Signal: yes
- 11 available communication channels
- Ultra-low power consumption – 5 years battery life with 4 updates / day
- Customer-replaceable battery
- Full graphical 2.7 inch e-Ink display with paper-like readability
- Changeable and customizable front covers
- Super wide viewing angle (nearly 180 degrees)
- Flexible mounting options available
- Supports 8 multiple pages with preloading and fast page switching
- May be used in landscape and portrait mode
- Fast response time (less than 15 seconds)
- water resistant
- 128-bit AES encryption with secure key exchange
- 5 000 label updates per hour and AP

2 Mechanical Characteristics

2.1 Technical characteristics

The imago G1 2.7 is made of several external parts:

1. Battery Cover including
 - a. Label ID
 - b. Label ID barcode
 - c. S/N
2. Battery pack
3. Main Unit including
 - a. Back Cover
 - b. PCB
 - c. Display
 - d. Transparent Front Cover
4. Front Cover Frame
 - a. Customizable in design and color
 - b. Replaceable

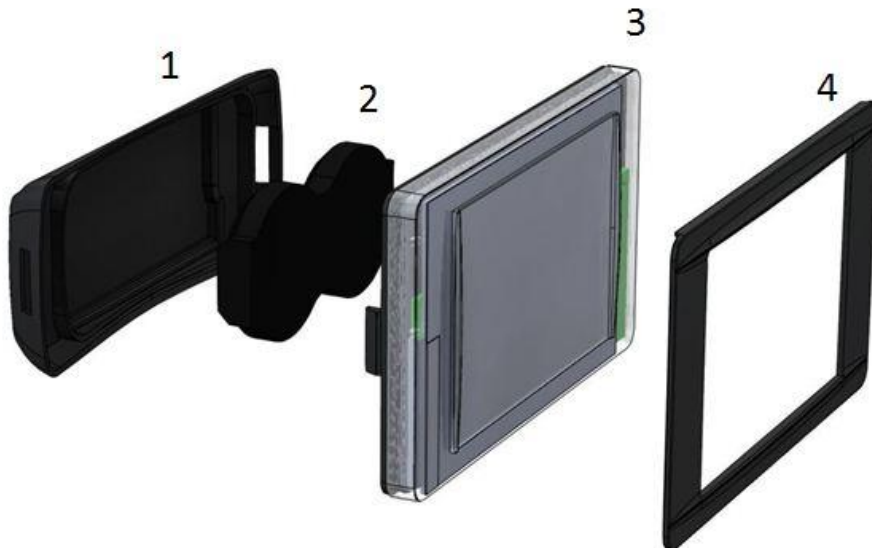

2.2 Mechanical Dimensions

Outline (mm): 86.3 x 49.5 x 16.2

Weight: 50 g

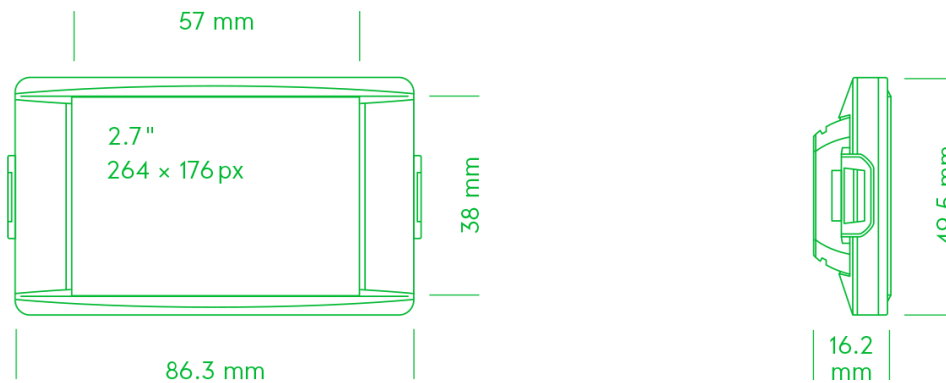

Scale 1:2

2.3 Barcode Information

The labels come with a label ID (which is a unique identifier – just like a MAC address) and this label ID as a barcode on the display (and printed on the back of the label).

The label ID consists of 8 hexadecimal digits (0-9 / A-F). The first 2 digits identify the different label types, shown on the following table:

Caption	Label-ID	Display resolution	DPIs	Display colors	Pages
imago G1 2.0	A1xxxxxx	200 × 96	111 dpi	Monochrom (1 bit)	9
imago G1 2.7	B3xxxxxx	264 × 176	117 dpi	Monochrom (1 bit)	9
imago G1 4.4	C1xxxxxx	400 x 300	113 dpi	Monochrom (1 bit)	13
imago G1 7.4	D1xxxxxx	480 x 800	126 dpi	Monochrom (1 bit)	13

2.4 Serial Number

Part	Description	Format	Example	Comment	Source
A	Production fab	2 alpha	01		Specified by imagotag once for each fab
B	Product family	2 alpha	G1		Specified by imagotag in the product specification document
C	Type identifier	2 hex	B3		
D	Product version	2 alpha	01		
E	Product revision	3 alpha	001	Incremented on every change of product specification	
-	Separator	"_"	-		Fixed
F	Internal	1 alpha	B	Internal	Calculated during production
G	Year	1 dec	4		
H	Week	2 dec	10	Calendar week in current year (01-53)	
I	Weekday	1 dec	3		
J	Internal	5 dec	00060	Continuous Serial Number (Counter)	

Format: AABBCDDDEEE- FGHHIJJJJJ

Example: 01G1B301001- B410300060

Note:

- Calendar week date is calculated according to ISO 8601 (see http://en.wikipedia.org/wiki/ISO_week_date)

3 Electrical & RF Characteristics

3.1 Power and Current Consumption

The power supply are 2x cell-button batteries, model CR2450. It delivers a 3V operating voltage and 1 100 mAh nominal capacity.

Power consumption measurements indicate that the G1 2.7 has the following patterns:

- Standby mode (standby radio) : $\leq 1 \mu\text{A}$
- Standby mode (active radio) $\leq 8 \text{ mA}$
- Active mode (active radio and active data processing) $\leq 35 \text{ mA}$

Battery pack (2x CR2450 nominal) lifetime - 5 years (at max. 4 updates per day)

Note: battery lifetime can vary depending on the operating conditions of the ESLs (temperature, radio usage etc...)

3.2 Transmission power

Each ESL has got a transmission power of $\leq 10 \text{ dBm}$ (according to the FCC certification).

4 E Ink Display

4.1 Overview

This is a 2.7" a-Si, active matrix TFT, Electronic Paper Display (EPD) panel. The panel has such high resolution (117 dpi) that it is able to easily display fine patterns. Due to its bi-stable nature, the EPD panel requires very little power to update and needs no power to maintain an image.

4.1.1 General Specifications

Item	Specification	Unit	Note
Outline Dimension	70.42(H) x 45.80(V) x 0.90(T)	mm	(1)
Active Area	57.288(H) x 38.192(V)	mm	
Driver Element	a-Si TFT active matrix	-	
FPL	V230	-	
Pixel Number	264 x 176	pixel	
Pixel Pitch	0.217 x 0.217 (117dpi)	mm	
Pixel Arrangement	Vertical stripe	-	
Display Colors	Black/White	-	
Surface Treatment	Anti-Glare	-	

Note (1): Not including the FPC

5 Environmental

5.1 Operating Conditions

Temperature: 0° C to + 45° C

Humidity: 10% to 80% (non-condensing)

5.2 Cleaning Instructions

Clean the electronic label with the help of a damp cloth.

Note: Do not use liquid or aerosol cleaners and keep it away from water.

5.3 Storage Conditions

Temperature: -20 °C to + 70 °C

Humidity: 10% to 85% (non-condensing)

5.4 Humidity Conditions

Notes:

- High humidity combined with low temperature are not recommended
- Low temperature will reduce the battery lifetime

6 Battery Replacement

6.1 Audience

Only persons with the following knowledge are allowed to replace the battery:

- Battery
- Electronic assemblies like circuit board
- Compliance of the instructions

6.2 Instructions

- Risk of explosion through incorrect battery replacement.
- Use battery pack exclusive provided from the company imagotag GmbH.
- Keep attention that your hands are dry before you start with the replacement.
- Don't use sharps to open the label.
- Don't use your fingernails to open the label.
- Don't touch the circuit board of the open label.

6.3 Steps

1. Press both snap-in-mounts of the battery cover (backside of the label) until the battery cover detaches. Afterwards take the battery cover from the label.
2. Pull the white plug out of the socket, don't pull on the cable.
3. Take out the battery pack.
4. Put in the new battery pack.
5. Push the white plug in the socket.
6. Put the battery cover on the label casing.

7 Reliability Test Items

- High Temperature Operation
- Low Temperature Operation
- High Temperature/Humidity
- Operation
- High Temperature Storage
- Low Temperature Storage
- High Temperature/Humidity
- Storage
- Temperature Shock (Storage)
- Package Drop Test
- Package Random Vibration Test
- Food Contact Test

8 Packing

8.1 Packing Dimensions

DIMENSIONS				STACKING				QUANTITY	
	LENGTH	WIDTH	HEIGHT						
BOX	400	270	135		LAYER / UNIT	9		SETS / BOX	80
PALLET	1200	800	140		BOXES / LAYER	8		SETS / LAYER	640
UNIT	1200	800	1355		BOXES / UNIT	72		SETS / UNIT	5760

Imago G1 2.7 Labels / Box: 80

8.2 Ordering Information

You can choose between the following offered label colors:

Article Number	Model	Description
112306	2.7 white	imago G1 2.7" RAL 9003 (white)
110027	2.7 black	imago G1 2.7" RAL 7021 (black)
110026	2.7 window grey	imago G1 2.7" RAL 7040 (window grey)
110024	2.7 yellow green	imago G1 2.7" RAL 6018 (yellow green)
110025	2.7 traffic red	imago G1 2.7" RAL 3020 (traffic red)

8.2.1 Package size

- 80 labels / box

9 Certifications



Housing, board and the display of the ESL conform with the ROHS Directive



The product meets the EU safety, health and environmental protection requirements and has the approval of CE marking



Passed all tests according to "FOOD CONTACT" requirements

9.1 Applied Standards

Information Technology Equipment

EN 60950-1/A2:2013

UL 60950-1/A2:2014

CSA CAN/CSA-C22.2 NO.60950-1-07

EMV

EN 301489-17 V2.2.1

R&TTE

EN 300328 V1.8.1

Human Exposure to Electromagnetic Fields

EN 62479:2010

9.2 Declaration

The company imagotag GmbH declares on his own responsibility that the imago G1 2.7 corresponds to the standards mentioned above.

9.2.1 FCC

This device complies with part 15 of the FCC Rules. Operation is subject to the following two conditions: (1) This device may not cause harmful interference, and (2) this device must accept any interference received, including interference that may cause undesired operation.

Changes or modifications not expressly approved by the party responsible for compliance could void the authority to operate the equipment.

9.2.2 IC

This device complies with Industry Canada licence-exempt RSS standard(s). Operation is subject to the following two conditions: (1) this device may not cause interference, and (2) this device must accept any interference, including interference that may cause undesired operation of the device.

Le présent appareil est conforme aux CNR d'Industrie Canada applicables aux appareils radio exempts de licence. L'exploitation est autorisée aux deux conditions suivantes : (1) l'appareil ne doit pas produire de brouillage, et (2) l'appareil doit accepter tout brouillage radioélectrique subi, même si le brouillage est susceptible d'en compromettre le fonctionnement.

10 Security Terms



- Never dismantle the product because except battery there is no component which could be changed by someone who is not qualified.
- Don't drop it.
- Keep it away from water.
- Don't use the label with defective parts.
- Don't use the label with spare parts and accessories which are not examined and approved by the imagotag GmbH.
- Unauthorized changes or modifications to the electronic label and their components without the consent of imagotag GmbH are not allowed.
- Don't heat, recharge or bend battery.
- Keep away batteries from children.
- Don't throw defective batteries into the dustbin. Give them to a reprocessing company.
- Don't throw ESL into the dustbin. Give them to a reprocessing company.
- Contact imagotag GmbH for more details about this process.