



# CONTROLLER 8

---

## RADIO REMOTE CONTROL 8 OUTPUTS

### USER AND MAINTENANCE MANUAL

---

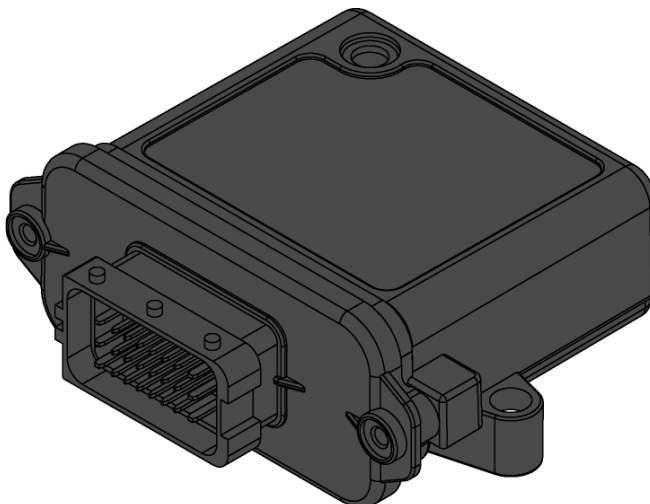

---

#### WARNINGS

This manual is an essential part of the device and it should be thoroughly kept for later consultation. Carefully read the warnings contained in this manual, concerning safety and a proper preservation of the product. These warnings are always to be carefully read before using the device. SISTEMATICA S.p.A. declines all responsibility for any trouble arising from the non-compliance with these warnings.

- DO NOT TRAVEL WITH THE DEVICE SWITCHED ON
- CONNECT THE SYSTEM ONLY TO THE VEHICLE'S BATTERY
- BEFORE CARRYING OUT ANY MECHANICAL MAINTENANCE OPERATION (WELDING) ON THE VEHICLE, DISCONNECT THE BATTERY CLIPS.
- AVOID ATTEMPTING TO REPAIR THE DEVICE BY YOURSELF. REPAIRS PERFORMED BY UNSKILLED PEOPLE CAN CAUSE SERIOUS DAMAGES OR FAILURES. FOR ASSISTANCE, APPLY TO YOUR LOCAL AUTHORIZED SERVICE CENTRE. USE ONLY ORIGINAL SPARE PARTS.
- ALWAYS KEEP AT A SAFE DISTANCE FROM THE MOVING PARTS.



## TECHNICAL FEATURES

- Manufacturer: SISTEMATICA S.p.A.
- Dimensions: 108x110x44
- Outputs number: up to 8
- Digital inputs number: 1
- IP protection: IP66
- Operating temperature:  $-20^{\circ}\text{C} \div +70^{\circ}\text{C}$
- Power supply voltage:  $12/24\text{ V} \pm 10\%$
- Current consumption (stanby): - 30 mA at 12 V  
- 30 mA at 24 V
- Max current per channel: 5 A
- Max total current: 10 A
- Main connector: FCI-SICMA 24 Header pin
- 8 bit microcontroller
- Reverse battery protection
- Internal antenna
- Emergency keyboard (option)
- Receiver category (EN 300-220-1): 2

## SYSTEM CODING

Coding the system is an operation that is only necessary when the receiver has to be replaced or you want to use it with a different SISTEMATICA radio remote control from the one it is coupled with at the time of purchase.

For a correct coding procedure, perform the following steps:

1. Disconnect the power to the receiver;
2. Open the receiver box, by unscrewing the 2 screws at the side of the connector;
3. Locate and press the coding pushbutton on the receiver board (figure 1);
4. Put power into the receiver by keeping the coding pushbutton pressed for 3-4 sec.; the yellow led on the receiver board flashes two time per second; so release the coding pushbutton;
5. Press any 3 keys at the same time on the transmitter within 15 seconds since it has been switched on (also more time if it is necessary; the yellow led stop to blink);
6. At this time, the transmitter is codified with the receiver; check all the system function by trying the movements of the system;
7. Close the receiver box by screwing the two screw removed at step 2.

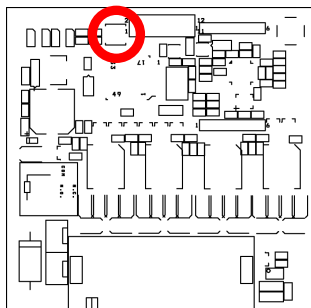

Figure 1. Coding pushbutton

## RELAY MOTOR RESETTING

The relay motor resetting is an operation to carry out in order to change its coupling with the other outputs (OUT1, OUT2, OUT3...) from the original standard system setting.



**By a standard system setting when any key is pressed on the radio control transmitter the correspondent output and relay motor output is activated. (see "Instructions for use" in the radio control transmitter manual).**

To change therealy motor output coupling with the output requie, it is necessary to act as follows:

1. Disconnect the power to the receiver;
2. Open the receiver box, by unscrewing the 2 screws at the side of the connector;
3. Put power into the receiver;
4. Press simultaneously the coding button on the receiver board (fig. 1) and **START** key on the transmitter for 3-4 sec., so release the 2 keys;
5. Activate in a row, by the transmitter, the outputs that are to be coupled with the relay motor;
6. Press simultaneously the coding button on the receiver board (fig. 1) and **STOP** key on the transmitter for 3-4 sec., so release the 2 keys;
7. At this time the new output and relay motor coupling is recorded; check all the system function by trying the movements of the system;
8. Close the receiver box by screwing the two screw removed at step 2.

In case any error should occur while resetting the system, it is possible to cancel the operation, by taking the power off the system and repeating the operation.



## POSITIONING OF THE RECEIVER UNIT, DIMENSION AND DRILLING TEMPLATE

For a proper functioning, locate the receiver type CONTROLLER 20 with the cable output downwards, as shown in the picture below:



The receiver is provided with an integrated antenna; be sure to locate it at sight, not inside any metal box or screened by ferrous masses (ex. Protection carter...)

### POSITIONING OF RECEIVER UNIT

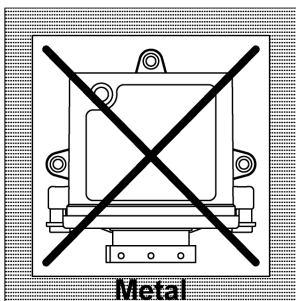
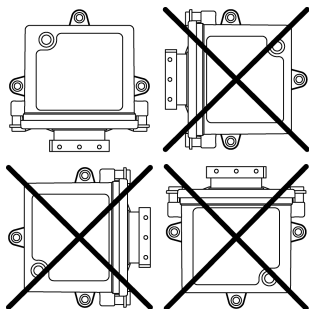

### RECEIVER DIMENSION

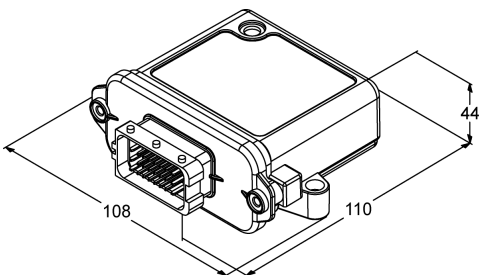

### DRILLING TEMPLATE DIMENSION

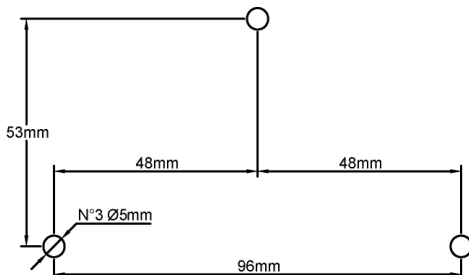

## FUSE REPLACEMENT

The system is automatically protected from power overload and from possible short-circuit on corresponding outputs. For further protection is also provided an internal fuse within the box. For replacing the damaged fuse, please proceed as follows:

1. Disconnect the power to the receiver;
2. Open the receiver box, by unscrewing the 2 screws at the side of the connector;
3. Locate the damage fuse on the receiver board;
4. Take the damaged fuse out of its holder and insert the new fuse, (F1= 15 A);
5. Put power into the receiver; to check that the fuse has been correctly replaced, try one or more movements of the system;
6. Close the receiver box by screwing the two screw removed at step 2.

## PRODUCT IDENTIFYING LABELS

000000

Internal label



External label

CNTR8: product model  
S/N: product serial number  
Cod.: product identification number



Removal of the identifying labels entails lapin of the guarantee conditions and the responsibility of SISTEMATICA S.p.A. with respect to component bodies



## PROBLEM IDENTIFICATION AND SOLUTION

PROBLEM	POSSIBLE CAUSES	SOLUTIONS
The system does not respond to the controls	Absence of power in the receiver unit	-Check that the emergency mushroom button on the transmitter (if present) is in the release position. -Check that the vehicle batterie is correctly connected to the receiver unit -Check that the fuse inside the receiver unit is intact, and if it is not, replace it (see "FUSE REPLACEMENT")
	Incorrect connection of the cabling to the utilities	-Check the cabling to indicators, electro-valves etc.
	Incorrect installation of the receiver	-The receiver must not be shielded by ferrous masses (see "POSITIONING OF THE RECEIVER UNIT")
	Incorrect replacement of the batteries	-Check that the batteries have been inserted correctly; if necessary replace them (see "REPLACEMENT THE BATTERIES" on the manual of the transmitter combined)
	System not coded	-Re-code the system (vedi "CODIFYING THE SYSTEM")
	Blown fuse	-Replacement of the fuse on the receiver board (see "FUSE REPLACEMENT")
The GREEN led on the remote control does not light up when a key is pressed	Flat batteries	-Replacement of the transmitter batteries (vedi "REPLACEMENT THE BATTERIES" on the manual of the transmitter combined)
	Batteries almost flat	
The system responds to the controls in a discontinuous way	Using the transmitter beyond its maximum range	-Keep to a distance $\leq$ 120m from the receiver
	Connection to the battery and to the utilities made with cables of unsuitable section or lenght	-Check that the connection to the battery and the utilities are made with cables of suitable section and lenght

## ANNEX

- Annex A: WIRING
- Annex B: EMERGENCY KEYBOARD (only if receiver with emergency keyboard)

## CE MARK

# CE 0051

**CE** Declaration of conformity for Sistematica S.p.A. products can be required at: [info@sistematica.it](mailto:info@sistematica.it)

**!** This product may be subjected to usage restriction. Please contact [info@sistematica.it](mailto:info@sistematica.it) for any further questions.

## FCC STATEMENTS

These devices complies with Part 15 of the FCC rules.

Operation is subject to the following two conditions:

- (1) these devices may not cause harmful interference and
- (2) these devices must accept any interference received, including interference that may cause undesired operation.

NOTE: The manufacturer is not responsible for any radio or tv interference caused by unauthorized modifications to these equipment. Such modifications could void the user's authority to operate the equipments.

SISTEMATICA S.p.A. Grantee Code: 081



TRENDTX label example  
FCC ID: 081CONTROLLER8