

# *Bestguarder*

## **Wireless Hunting & Security Alarm**

**Model:SY-007**



### **INSTRUCTION MANUAL**

**Welcome to buy SY-007 wireless hunting & security alarm. For making best use of all functions of the camera, please read this user's manual carefully before using it.**

## I. Overview

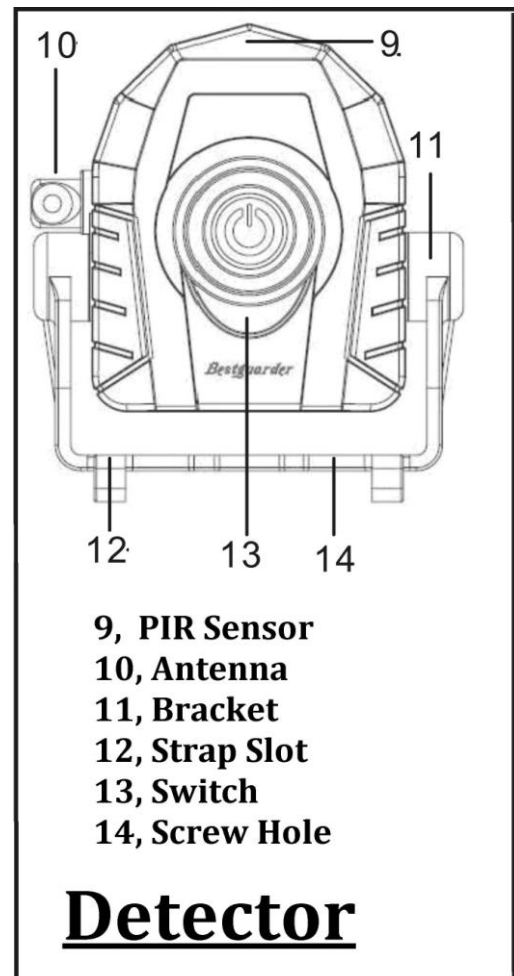
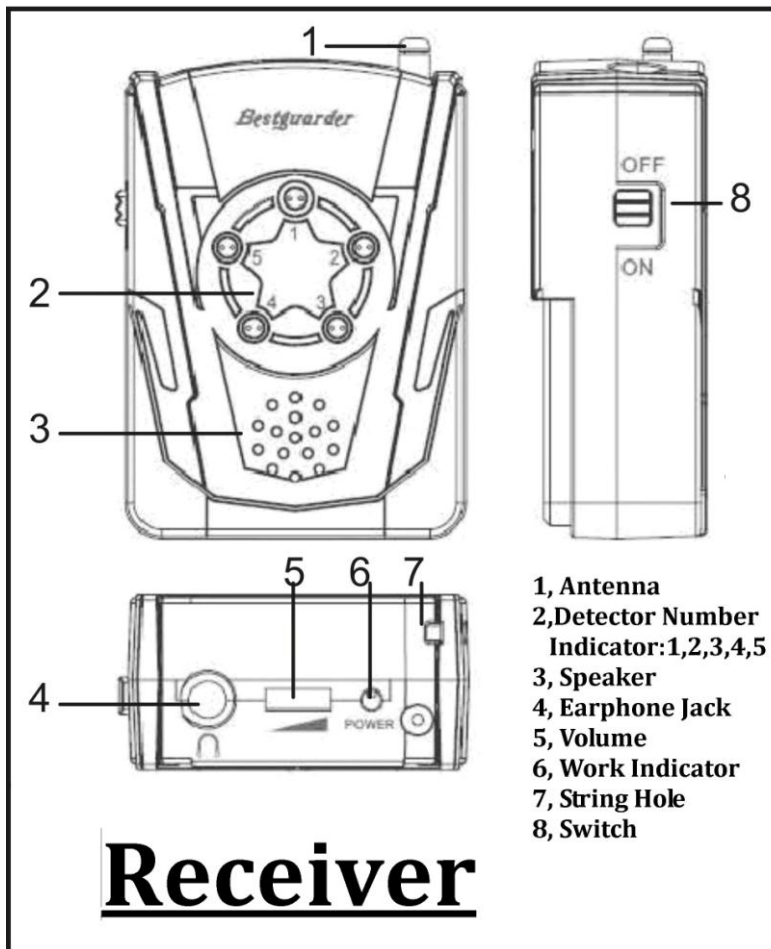

## II. General Information

SY-007 wireless alarm for guard hunting and driven hunting, and security, comprising receiver and detector specially designed for hunting of wild game, home security.

Receiver can accept Max 5 detectors

Easy to use, receiver connect with detector automatically,

### Three alarm mode of Receiver

#### Sound alarm

The receiver automatically goes into sound alarm 15s per trigger by detector. Volume can be adjusted.

### **Vibration alarm**

The receiver automatically goes into vibration alarm 15s per trigger by detector.

### **Lighting alarm**

The receiver automatically goes into lighting alarm and light flash 15s per trigger by detector. Detector no. indicator is always lighting after a trigger, until next trigger to flash.

## **III. Start Guide**

### **★ Caution:**

- 1, The Receiver is designed not to be weather resistant. Never attempt to raining, immerse the unit in water or any other liquid. This will damage the unit and void the warranty.
- 2, The Detector is designed only to be weather resistant IP66. Never attempt to immerse the unit in water or any other liquid. This will damage the unit and void the warranty.
- 3, Please use good quality 3\*AAA batteries and take out batteries when camera is free long time.

### **Power On**

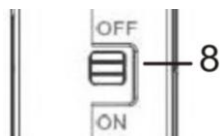

Receiver: Switch to On position after putting 3\*AAA batteries, receiver Vibrate 15s (Sound 15s/Indicator lighting 15s) after connecting detector (1-5pcs) automatically once power on.

Detector No. indicator is always lighting after a trigger, until next trigger to flash.



Detector: Press button 2seconds to power on, green LED is lighting 2s then shut down. Detector connect receiver automatically once power on.

### **Location of Detector**

To get a optimal detect, it is recommend to mount a tree at 3,6,9 meters away from the place to be monitored, and at a height of 0.3-2meters.

Be sure to avoid mounting detector in an environment where there is motion associated with tree branches/cloth creating motion or an area where there is high heat in the foreground.

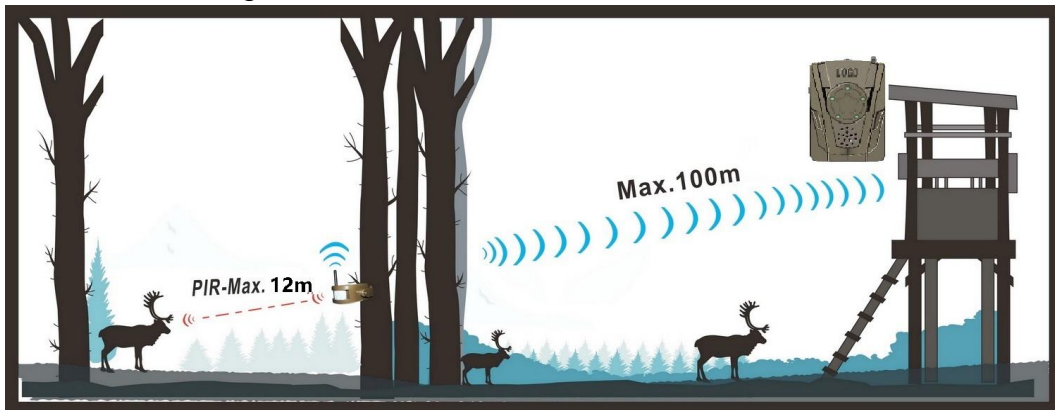

## V. Specification

Distance between receiver and detector	≤100m
Detector PIR distance	≤12m
Wireless Radio Frequency	433.92MHz
PIR angle	70°
PIR trigger	≤0.5秒
Alarm sounds	15s, volume adjust
Vibration	15s
Power	3* AAA
Receiver battery life	100hours
Detector battery life	400hours
Receiver power consumption	≤8mA, 4.5V
Detector power consumption	≤2mA, 4.5V
Detector Watt	≤25mW
Receiver Size:	80x55 x40 mm
Detector Size:	140 x100 x40 mm
Operate/Storage temperature	-20 - +60°C / -30 - +70°C
Humidity	5% - 90%
Water Resistance(Detector)	IP66
Security Authentication	FCC ID

## FCC Caution.

This device complies with part 15 of the FCC Rules. Operation is subject to the following two conditions: (1) This device may not cause harmful interference, and (2) this device must accept any interference received, including interference that may cause undesired operation.

Any Changes or modifications not expressly approved by the party responsible for compliance could void the user's authority to operate the equipment.

Note: This equipment has been tested and found to comply with the limits for a Class B digital device, pursuant to part 15 of the FCC Rules. These limits are designed to provide reasonable protection against harmful interference in a residential installation. This equipment generates uses and can radiate radio frequency energy and, if not installed and used in accordance with the instructions, may cause harmful interference to radio communications. However, there is no guarantee that interference will not occur in a particular installation. If this equipment does cause harmful interference to radio or television reception, which can be determined by turning the equipment off and on, the user is encouraged to try to correct the interference by one or more of the following measures:

- Reorient or relocate the receiving antenna.
- Increase the separation between the equipment and receiver.
- Connect the equipment into an outlet on a circuit different from that to which the receiver is connected.
- Consult the dealer or an experienced radio/TV technician for help.